

KV-700 - 8000 SIO Driver

1	System Configuration.....	3
2	External Device Selection	11
3	Communication Settings	12
4	Setup Items	81
5	Cable Diagrams	86
6	Supported Device.....	105
7	Device Code and Address Code.....	115
8	Error Messages.....	121

Introduction

This manual describes how to connect the Display and the External Device (target PLC).

In this manual, the connection procedure is described in the sections identified below.

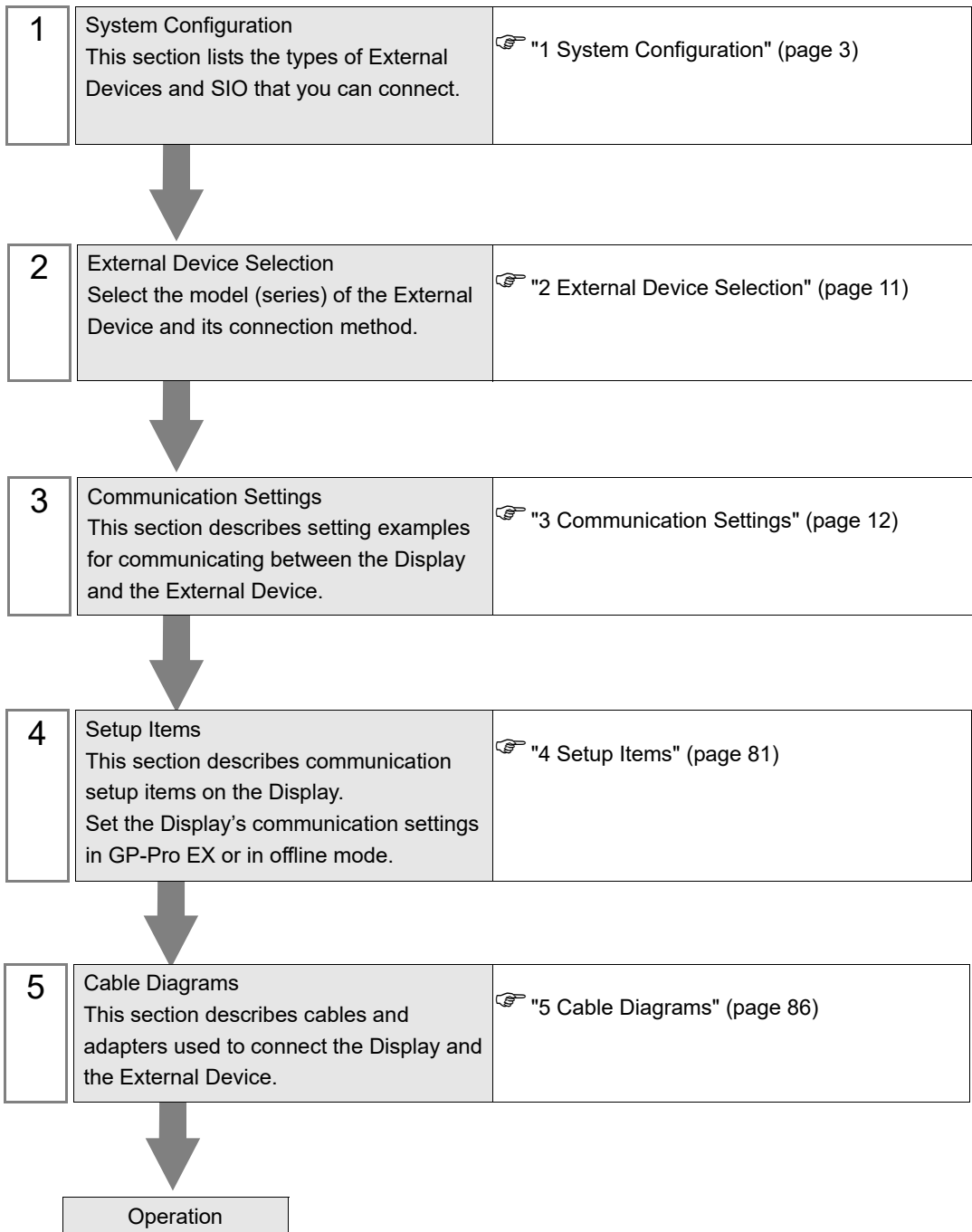

1 System Configuration

The following table lists system configurations for connecting KEYENCE Corporation External Devices and the Display.

Series	CPU	Link I/F	SIO Type	Setting Example	Cable Diagram
KV-700 Series	KV-700	CPU Direct*1	RS-232C	Setting Example 1 (page 12)	Cable Diagram 1 (page 86)
		KV-L20	RS-232C (Port 1 connection)	Setting Example 2 (page 14)	Cable Diagram 2 (page 88)
			RS-232C (Port 2 connection)	Setting Example 4 (page 18)	Cable Diagram 3 (page 90)
			RS-422/485 (4wire) (Port 2 connection)	Setting Example 6 (page 22)	Cable Diagram 4 (page 92)
		KV-L20R	RS-232C (Port 1 connection)	Setting Example 3 (page 16)	Cable Diagram 2 (page 88)
			RS-232C (Port 2 connection)	Setting Example 5 (page 20)	Cable Diagram 3 (page 90)
			RS-422/485 (4wire) (Port 2 connection)	Setting Example 7 (page 24)	Cable Diagram 4 (page 92)
		KV-L20V*2	RS-232C (Port 1 connection)	Setting Example 8 (page 26)	Cable Diagram 2 (page 88)
			RS-232C (Port 2 connection)	Setting Example 9 (page 28)	Cable Diagram 3 (page 90)
			RS-422/485 (4wire) (Port 2 connection)	Setting Example 10 (page 30)	Cable Diagram 4 (page 92)

Series	CPU	Link I/F	SIO Type	Setting Example	Cable Diagram		
KV-1000 Series	KV-1000	CPU Direct*1	RS-232C	Setting Example 1 (page 12)	Cable Diagram 1 (page 86)		
		KV-L20R	RS-232C (Port 1 connection)	Setting Example 3 (page 16)	Cable Diagram 2 (page 88)		
			RS-232C (Port 2 connection)	Setting Example 5 (page 20)	Cable Diagram 3 (page 90)		
			RS-422/485 (4wire) (Port 2 connection)	Setting Example 7 (page 24)	Cable Diagram 4 (page 92)		
		KV-L20V*2	RS-232C (Port 1 connection)	Setting Example 8 (page 26)	Cable Diagram 2 (page 88)		
			RS-232C (Port 2 connection)	Setting Example 9 (page 28)	Cable Diagram 3 (page 90)		
			RS-422/485 (4wire) (Port 2 connection)	Setting Example 10 (page 30)	Cable Diagram 4 (page 92)		
		KV-3000 Series	KV-3000	CPU Direct*1	RS-232C	Setting Example 11 (page 32)	Cable Diagram 1 (page 86)
				KV-L20V*2	RS-232C (Port 1 connection)	Setting Example 12 (page 33)	Cable Diagram 2 (page 88)
RS-232C (Port 2 connection)	Setting Example 13 (page 35)				Cable Diagram 3 (page 90)		
RS-422/485 (4wire) (Port 2 connection)	Setting Example 14 (page 37)				Cable Diagram 4 (page 92)		
KV-5000 Series	KV-5000	KV-L20V*2	RS-232C (Port 1 connection)	Setting Example 12 (page 33)	Cable Diagram 2 (page 88)		
			RS-232C (Port 2 connection)	Setting Example 13 (page 35)	Cable Diagram 3 (page 90)		
			RS-422/485 (4wire) (Port 2 connection)	Setting Example 14 (page 37)	Cable Diagram 4 (page 92)		

Series	CPU	Link I/F	SIO Type	Setting Example	Cable Diagram
KV-5500 Series	KV-5500	KV-L20V*3	RS-232C (Port 1 connection)	Setting Example 15 (page 39)	Cable Diagram 2 (page 88)
			RS-232C (Port 2 connection)	Setting Example 16 (page 41)	Cable Diagram 3 (page 90)
			RS-422/485 (4wire) (Port 2 connection)	Setting Example 17 (page 43)	Cable Diagram 4 (page 92)
KV-7000 Series	KV-7300*4	CPU Direc *1	RS232C	Setting Example 19 (page 47)	Cable Diagram 1 (page 86)
		KV-L20V	RS232C (Port 1 connection)	Setting Example 20 (page 49)	Cable Diagram 2 (page 88)
			RS232C (Port 2 connection)	Setting Example 21 (page 51)	Cable Diagram 3 (page 90)
			RS-422/485 (4wire) (Port 2 connection)	Setting Example 22 (page 53)	Cable Diagram 4 (page 92)
		KV-L21V	RS232C (Port 1 connection)	Setting Example 20 (page 49)	Cable Diagram 2 (page 88)
			RS232C (Port 2 connection)	Setting Example 21 (page 51)	Cable Diagram 3 (page 90)
			RS-422/485 (4wire) (Port 2 connection)	Setting Example 22 (page 53)	Cable Diagram 4 (page 92)
			RS-422/485 (2wire) (Port 2 connection)	Setting Example 23 (page 55)	Cable Diagram 5 (page 98)

Series	CPU	Link I/F	SIO Type	Setting Example	Cable Diagram
KV-7000 Series	KV-7500*4	KV-L20V	RS232C (Port 1 connection)	Setting Example 20 (page 49)	Cable Diagram 2 (page 88)
			RS232C (Port 2 connection)	Setting Example 21 (page 51)	Cable Diagram 3 (page 90)
			RS-422/485 (4wire) (Port 2 connection)	Setting Example 22 (page 53)	Cable Diagram 4 (page 92)
		KV-L21V	RS232C (Port 1 connection)	Setting Example 20 (page 49)	Cable Diagram 2 (page 88)
			RS232C (Port 2 connection)	Setting Example 21 (page 51)	Cable Diagram 3 (page 90)
			RS-422/485 (4wire) (Port 2 connection)	Setting Example 22 (page 53)	Cable Diagram 4 (page 92)
			RS-422/485 (2wire) (Port 2 connection)	Setting Example 23 (page 55)	Cable Diagram 5 (page 98)
		KV-Nano Series	KV-N14 KV-N24 KV-N40	CPU Direc *1*5	RS232C
KV-N60*5	CPU Direc *1		RS232C	Setting Example 18 (page 45)	Cable Diagram 1 (page 86)
	KV-N10L		RS232C	Setting Example 24 (page 57)	Cable Diagram 2 (page 88)
	KV-N11L		RS-422/485 (4wire)	Setting Example 25 (page 59)	Cable Diagram 4 (page 92)
			RS-422/485 (2wire)	Setting Example 26 (page 61)	Cable Diagram 5 (page 98)

Series	CPU	Link I/F	SIO Type	Setting Example	Cable Diagram
KV-Nano Series	KV-NC32T*6	CPU Direc *1	RS232C	Setting Example 18 (page 45)	Cable Diagram 1 (page 86)
		KV-NC10L	RS232C	Setting Example 27 (page 63)	Cable Diagram 2 (page 88)
		KV-NC20L	RS232C (Port 1 connection)	Setting Example 28 (page 65)	Cable Diagram 2 (page 88)
			RS232C (Port 2 connection)	Setting Example 29 (page 67)	Cable Diagram 3 (page 90)
			RS-422/485 (4wire) (Port 2 connection)	Setting Example 30 (page 69)	Cable Diagram 4 (page 92)
			RS-422/485 (2wire) (Port 2 connection)	Setting Example 31 (page 71)	Cable Diagram 5 (page 98)
		KV-8000 Series	KV-8000*7	KV-L20V	RS232C (Port 1 connection)
RS232C (Port 2 connection)	Setting Example 33 (page 75)				Cable Diagram 3 (page 90)
RS-422/485 (4wire) (Port 2 connection)	Setting Example 34 (page 77)				Cable Diagram 4 (page 92)
KV-L21V	RS232C (Port 1 connection)			Setting Example 32 (page 73)	Cable Diagram 2 (page 88)
	RS232C (Port 2 connection)			Setting Example 33 (page 75)	Cable Diagram 3 (page 90)
	RS-422/485 (4wire) (Port 2 connection)			Setting Example 34 (page 77)	Cable Diagram 4 (page 92)
	RS-422/485 (2wire) (Port 2 connection)			Setting Example 35 (page 79)	Cable Diagram 5 (page 98)

*1 Using modular connector on CPU.

*2 For communication settings, KV STUDIO Ver. 4 or later ladder software is required.

*3 For communication settings, KV STUDIO Ver. 6 or later ladder software is required.

*4 For communication settings, KV STUDIO Ver. 8 or later ladder software is required.

*5 For communication settings, KV STUDIO Ver. 7 or later ladder software is required.

*6 For communication settings, KV STUDIO Ver. 7.1 or later ladder software is required.

*7 For communication settings, KV STUDIO Ver. 10 or later ladder software is required.

■ IPC COM Port

When connecting IPC with an External Device, the COM port used depends on the series and SIO type. Please refer to the IPC manual for details.

Usable port

Series	Usable Port		
	RS-232C	RS-422/485(4 wire)	RS-422/485(2 wire)
PS-2000B	COM1 ^{*1} , COM2, COM3 ^{*1} , COM4	-	-
PS-3450A, PS-3451A, PS3000-BA, PS3001-BD	COM1, COM2 ^{*1*2}	COM2 ^{*1*2}	COM2 ^{*1*2}
PS-3650A (T41 model), PS-3651A (T41 model)	COM1 ^{*1}	-	-
PS-3650A (T42 model), PS-3651A (T42 model)	COM1 ^{*1*2} , COM2	COM1 ^{*1*2}	COM1 ^{*1*2}
PS-3700A (Pentium®4-M) PS-3710A	COM1 ^{*1} , COM2 ^{*1} , COM3 ^{*2} , COM4	COM3 ^{*2}	COM3 ^{*2}
PS-3711A	COM1 ^{*1} , COM2 ^{*2}	COM2 ^{*2}	COM2 ^{*2}
PS4000 ^{*3}	COM1, COM2	-	-
PL3000	COM1 ^{*1*2} , COM2 ^{*1} , COM3, COM4	COM1 ^{*1*2}	COM1 ^{*1*2}
PE-4000B Atom N270	COM1, COM2	-	-
PE-4000B Atom N2600	COM1, COM2	COM3 ^{*4} , COM4 ^{*4} , COM5 ^{*4} , COM6 ^{*4}	COM3 ^{*4} , COM4 ^{*4} , COM5 ^{*4} , COM6 ^{*4}
PS5000 (Slim Panel Type Core i3 Model) ^{*5*6}	COM1, COM2 ^{*4}	COM2 ^{*4}	COM2 ^{*4}
PS5000 (Slim Panel Type Atom Model) ^{*5*6}	COM1, COM2 ^{*7}	COM2 ^{*7}	COM2 ^{*7}
PS5000 (Enclosed Panel Type) ^{*8}	COM1	-	-
PS5000 (Modular Type PFXPU/PFXPP) ^{*5*6} PS5000 (Modular Type PFXPL2B5-6)	COM1 ^{*7}	COM1 ^{*7}	COM1 ^{*7}
PS5000 (Modular Type PFXPL2B1-4)	COM1, COM2 ^{*7}	COM2 ^{*7}	COM2 ^{*7}
PS6000	COM1 ^{*9}	^{*10}	^{*10}

*1 The RI/5V can be switched. Use the IPC's switch to change if necessary.

*2 Set up the SIO type with the DIP Switch. Please set up as follows according to SIO type to be used.

*3 When making communication between an External Device and COM port on the Expansion slot, only RS-232C is supported. However, ER (DTR/CTS) control cannot be executed because of the specification of COM port.

For connection with External Device, use user-created cables and disable Pin Nos. 1, 4, 6 and 9. Please refer to the IPC manual for details of pin layout.

*4 Set up the SIO type with the BIOS. Please refer to the IPC manual for details of BIOS.

- *5 When setting up communication between an External Device and the RS-232C/422/485 interface module, use the IPC (RS-232C) or PS5000 (RS-422/485) cable diagrams. However, when using PFXZPBMPR42P2 in a RS-422/485 (4-wire) configuration with no flow control, connect 7.RTS+ and 8.CTS+, and connect 6.RTS- and 9.CTS-.
- When using RS-422/485 communication with External Devices, you may need to reduce the transmission speed and increase the TX Wait time.
- *6 To use RS-422/485 communication on the RS-232C/422/485 interface module, the DIP Switch setting is required. Please refer to "Knowledge Base" (FAQs) on the support site. (<http://www.pro-face.com/trans/en/manual/1001.html>)

Settings	FAQ ID
PFXZPBMPR42P2, RS422/485 change method	FA263858
PFXZPBMPR42P2 termination resistor setting	FA263974
PFXZPBMPR44P2, RS422/485 change method	FA264087
PFXZPBMPR44P2 termination resistor setting	FA264088

- *7 Set up the SIO type with the DIP Switch. Please refer to the IPC manual for details of DIP Switch. The BOX Atom has not a switch to set the RS-232C, RS-422/485 mode. Use the BIOS for the setting.
- *8 For the connection with the External Device, on the user-created cable read as if the connector on the Display-side is a M12 A-coding 8 pin socket. The pin assignment is the same as described in the cable diagram. For the M12 A-coding connector, use PFXZPSCNM122.
- *9 In addition to COM1, you can also use the RS-232C COM port on the optional interface.
- *10 Install the optional interface in the expansion slot.

DIP Switch settings (PL3000 / PS3000 Series)

RS-232C

DIP Switch	Setting	Description
1	OFF*1	Reserved (always OFF)
2	OFF	SIO type: RS-232C
3	OFF	
4	OFF	Output mode of SD (TXD) data: Always output
5	OFF	Terminal resistance (220Ω) insertion to SD (TXD): None
6	OFF	Terminal resistance (220Ω) insertion to RD (RXD): None
7	OFF	Short-circuit of SDA (TXA) and RDA (RXA): Not available
8	OFF	Short-circuit of SDB (TXB) and RDB (RXB): Not available
9	OFF	RS (RTS) Auto control mode: Disabled
10	OFF	

*1 When using PS-3450A, PS-3451A, PS3000-BA and PS3001-BD, turn ON the set value.

RS-422/485 (4 wire)

DIP Switch	Setting	Description
1	OFF	Reserved (always OFF)
2	ON	SIO type: RS-422/485
3	ON	
4	OFF	Output mode of SD (TXD) data: Always output
5	OFF	Terminal resistance (220Ω) insertion to SD (TXD): None
6	OFF	Terminal resistance (220Ω) insertion to RD (RXD): None
7	OFF	Short-circuit of SDA (TXA) and RDA (RXA): Not available
8	OFF	Short-circuit of SDB (TXB) and RDB (RXB): Not available
9	OFF	RS (RTS) Auto control mode: Disabled
10	OFF	

RS-422/485 (2 wire)

DIP Switch	Setting	Description
1	OFF	Reserved (always OFF)
2	ON	SIO type: RS-422/485
3	ON	
4	OFF	Output mode of SD (TXD) data: Always output
5	OFF	Terminal resistance (220Ω) insertion to SD (TXD): None
6	OFF	Terminal resistance (220Ω) insertion to RD (RXD): None
7	ON	Short-circuit of SDA (TXA) and RDA (RXA): Available
8	ON	Short-circuit of SDB (TXB) and RDB (RXB): Available
9	ON	RS (RTS) Auto control mode: Enabled
10	ON	

2 External Device Selection

Select the External Device to connect to the Display.

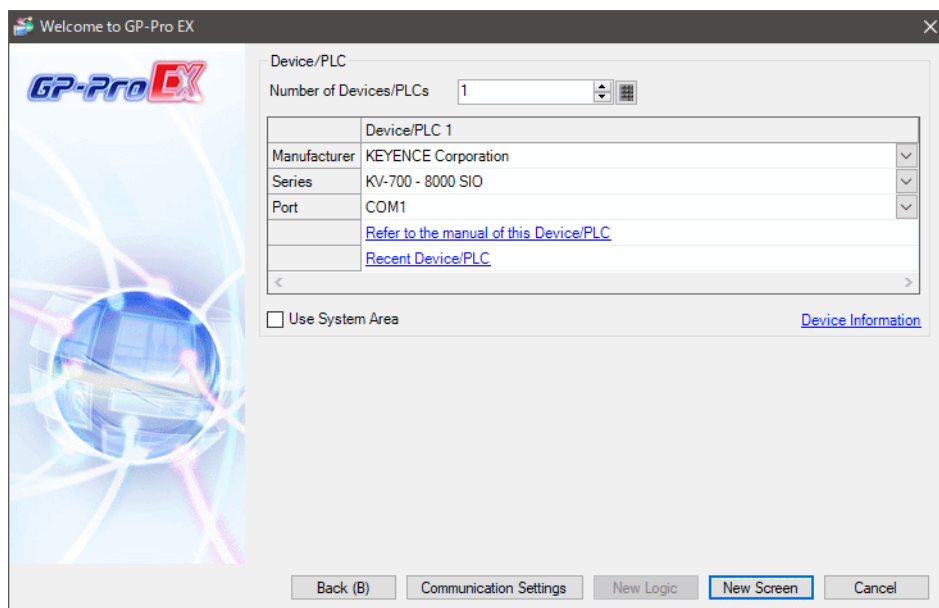

Setup Items	Setup Description
Number of Devices/PLCs	Enter an integer from 1 to 4 to define the number of Devices/PLCs to connect to the display.
Manufacturer	Select the manufacturer of the External Device to connect. Select "KEYENCE Corporation".
Series	Select the External Device model (series) and the connection method. Select "KV-700 - 8000 SIO". In System configuration, make sure the External Device you are connecting is supported by "KV-700 - 8000 SIO". ☞ "1 System Configuration" (page 3)
Port	Select the Display port to connect to the External Device.
Use System Area	Check this option to synchronize the system data area of the Display and the device (memory) of the External Device. When synchronized, you can use the External Device's ladder program to switch the display or display the window on the Display. Cf. GP-Pro EX Reference Manual "LS Area (Direct Access Method Area)" This feature can also be set in GP-Pro EX or in the Display's offline mode. Cf. GP-Pro EX Reference Manual "System Settings [Display Unit] - [System Area] Settings Guide" Cf. Maintenance/Troubleshooting Guide "Main Unit - System Area Settings"

3 Communication Settings

This section provides examples of communication settings recommended by Pro-face for the Display and the External Device.

3.1 Setting Example 1

■ GP-Pro EX Settings

◆ Communication Settings

To display the setup screen, from the [Project] menu, point to [System Settings] and select [Device/PLC].

Device/PLC 1

Summary [Change Device/PLC](#)

Manufacturer Series Port

Text Data Mode [Change](#)

Communication Settings

SIO Type RS232C RS422/485(2wire) RS422/485(4wire)

Speed

Data Length 7 8

Parity NONE EVEN ODD

Stop Bit 1 2

Flow Control NONE ER(DTR/CTS) XON/XOFF

Timeout (sec)

Retry

Wait To Send (ms)

RI / VCC RI VCC

In the case of RS232C, you can select the 9th pin to RI (Input) or VCC (5V Power Supply). If you use the Digital's RS232C Isolation Unit, please select it to VCC.

Device-Specific Settings

Allowable Number of Devices/PLCs

No.	Device Name	Settings	<input type="button" value="Add Indirect Device"/>
1	<input type="text" value="PLC1"/>	<input type="text" value="Series=KV-700/1000"/>	<input type="button" value="Add Indirect Device"/>

NOTE

- You can set the speed to 9600-57600bps for KV-700 Series, and 9600-115200 bps for KV-1000 Series.

◆ Device Setting

To display the [Individual Device Settings] dialog box, from [Device-Specific Settings] in the [Device/PLC] window, select the external device and click [Settings]  .

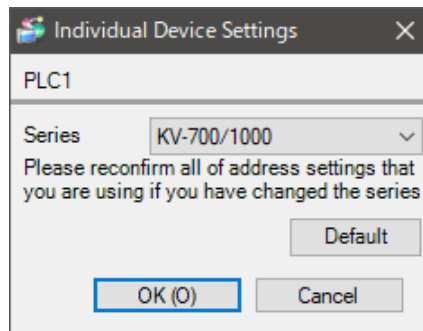

■ External Device Settings

There are no settings on the External Device. The speed automatically switches according to the Display settings.

3.2 Setting Example 2

■ GP-Pro EX Settings

To display the setup screen, from the [Project] menu, point to [System Settings] and select [Device/PLC].

Device/PLC 1

Summary [Change Device/PLC](#)

Manufacturer Series Port

Text Data Mode [Change](#)

Communication Settings

SIO Type RS232C RS422/485(2wire) RS422/485(4wire)

Speed

Data Length 7 8

Parity NONE EVEN ODD

Stop Bit 1 2

Flow Control NONE ER(DTR/CTS) XON/XOFF

Timeout (sec)

Retry

Wait To Send (ms)

RI / VCC RI VCC

In the case of RS232C, you can select the 9th pin to RI (Input) or VCC (5V Power Supply). If you use the Digital's RS232C Isolation Unit, please select it to VCC.

Device-Specific Settings

Allowable Number of Devices/PLCs

No.	Device Name	Settings
<input type="button" value="x"/> 1	<input type="text" value="PLC1"/>	<input type="text" value="Series=KV-700/1000"/>

◆ Device Setting

To display the [Individual Device Settings] dialog box, from [Device-Specific Settings] in the [Device/PLC] window, select the external device and click [Settings] .

Individual Device Settings

PLC1

Series

Please reconfirm all of address settings that you are using if you have changed the series

■ External Device Settings

Use the KEYENCE Corporation ladder software (KV STUDIO Ver. 4 or later) to configure communication settings for the External Device.

Refer to your External Device manual for details.

- (1) Start up the ladder software.
- (2) From the [File] menu, select [New Project] and display the [New Project] dialog box.
- (3) Type a project name in [Project Name], select the External Device to use under [PLC model], and click [OK].
- (4) Click [Yes] in the [Confirm unit setting information] dialog box and display the [Unit Editor] window.
- (5) Select "KV-L20" from the displayed unit list on the [Select unit] tab, and drag & drop it to the unit placement area.
- (6) Double-click "KV-L20" in the unit placement area.
- (7) Configure the following communication settings on the [Setup unit] tab.

Setup Items		Setup Description
Port 1	Operation Mode	KV BUILDER mode
	Interface	RS-232C
	Baud Rate	Auto
	Data Bit Length	8 bits
	Start Bit	1 bit
	Stop Bit	1 bit
	Parity	Even
	Check Sum	None
	RS/CS Flow Control	Disabled

- (8) From the [Convert] menu, select [Auto-assign relay/DM].
- (9) From the [File] menu, select [Close] and display the [Unit Editor] dialog box.
- (10) Click [Yes].
- (11) From the [Monitor/Simulator] menu, select [Transfer to PLC] to display the [Transfer Program] dialog box.
- (12) Check [Unit setting info] and [Program], and then click [Execute]. The setting information is transferred.

This completes the setting of the External Device.

3.3 Setting Example 3

■ GP-Pro EX Settings

To display the setup screen, from the [Project] menu, point to [System Settings] and select [Device/PLC].

Device/PLC 1

Summary [Change Device/PLC](#)

Manufacturer Series Port

Text Data Mode [Change](#)

Communication Settings

SIO Type RS232C RS422/485(2wire) RS422/485(4wire)

Speed

Data Length 7 8

Parity NONE EVEN ODD

Stop Bit 1 2

Flow Control NONE ER(DTR/CTS) XON/XOFF

Timeout (sec)

Retry

Wait To Send (ms)

RI / VCC RI VCC
In the case of RS232C, you can select the 9th pin to RI (Input) or VCC (5V Power Supply). If you use the Digital's RS232C Isolation Unit, please select it to VCC.

Device-Specific Settings

Allowable Number of Devices/PLCs

No.	Device Name	Settings
<input type="button" value="x"/> 1	<input type="text" value="PLC1"/>	<input type="text" value="Series=KV-700/1000"/>

◆ Device Setting

To display the [Individual Device Settings] dialog box, from [Device-Specific Settings] in the [Device/PLC] window, select the external device and click [Settings] .

Individual Device Settings

PLC1

Series

Please reconfirm all of address settings that you are using if you have changed the series

■ External Device Settings

Use the KEYENCE Corporation ladder software (KV STUDIO Ver. 4 or later) to configure communication settings for the External Device.

Refer to your External Device manual for details.

- (1) Start up the ladder software.
- (2) From the [File] menu, select [New Project] and display the [New Project] dialog box.
- (3) Type a project name in [Project Name], select the External Device to use under [PLC model], and click [OK].
- (4) Click [Yes] in the [Confirm unit setting information] dialog box and display the [Unit Editor] window.
- (5) Select "KV-L20R" from the displayed unit list on the [Select unit] tab, and drag & drop it to the unit placement area.
- (6) Double-click "KV-L20R" in the unit placement area.
- (7) Configure the following communication settings on the [Setup unit] tab.

Setup Items		Setup Description
Port 1	Operation Mode	KV BUILDER/KV STUDIO mode
	Interface	RS-232C
	Baud Rate	Auto
	Data Bit Length	8 bits
	Start Bit	1 bit
	Stop Bit	1 bit
	Parity	Even
	Check Sum	None
	RS/CS Flow Control	Disabled
Station No.	Station No.	0
Detail Settings	Transfer Timeout (sec.)	3

- (8) From the [Convert] menu, select [Auto-assign relay/DM].
- (9) From the [File] menu, select [Close] and display the [Unit Editor] dialog box.
- (10) Click [Yes].
- (11) From the [Monitor/Simulator] menu, select [Transfer to PLC] to display the [Transfer Program] dialog box.
- (12) Check [Unit setting info] and [Program], and then click [Execute]. The setting information is transferred.

This completes the setting of the External Device.

3.4 Setting Example 4

■ GP-Pro EX Settings

To display the setup screen, from the [Project] menu, point to [System Settings] and select [Device/PLC].

Device/PLC 1

Summary [Change Device/PLC](#)

Manufacturer Series Port

Text Data Mode [Change](#)

Communication Settings

SIO Type RS232C RS422/485(2wire) RS422/485(4wire)

Speed

Data Length 7 8

Parity NONE EVEN ODD

Stop Bit 1 2

Flow Control NONE ER(DTR/CTS) XON/XOFF

Timeout (sec)

Retry

Wait To Send (ms)

RI / VCC RI VCC

In the case of RS232C, you can select the 9th pin to RI (Input) or VCC (5V Power Supply). If you use the Digital's RS232C Isolation Unit, please select it to VCC.

Device-Specific Settings

Allowable Number of Devices/PLCs

No.	Device Name	Settings
<input type="button" value="1"/>	<input type="text" value="PLC1"/>	<input type="text" value="Series=KV-700/1000"/>

◆ Device Setting

To display the [Individual Device Settings] dialog box, from [Device-Specific Settings] in the [Device/PLC] window, select the external device and click [Settings] .

Individual Device Settings

PLC1

Series

Please reconfirm all of address settings that you are using if you have changed the series

■ External Device Settings

Use the KEYENCE Corporation ladder software (KV STUDIO Ver. 4 or later) to configure communication settings for the External Device.

Refer to your External Device manual for details.

- (1) Start up the ladder software.
- (2) From the [File] menu, select [New Project] and display the [New Project] dialog box.
- (3) Type a project name in [Project Name], select the External Device to use under [PLC model], and click [OK].
- (4) Click [Yes] in the [Confirm unit setting information] dialog box and display the [Unit Editor] window.
- (5) Select "KV-L20" from the displayed unit list on the [Select unit] tab, and drag & drop it to the unit placement area.
- (6) Double-click "KV-L20" in the unit placement area.
- (7) Configure the following communication settings on the [Setup unit] tab.

Setup Items		Setup Description
Port 2	Operation Mode	KV BUILDER mode
	Interface	RS-232C
	Station No.	0
	Baud Rate	Auto
	Data Bit Length	8 bits
	Start Bit	1 bit
	Stop Bit	1 bit
	Parity	Even
	Check Sum	None

- (8) From the [Convert] menu, select [Auto-assign relay/DM].
- (9) From the [File] menu, select [Close] and display the [Unit Editor] dialog box.
- (10) Click [Yes].
- (11) From the [Monitor/Simulator] menu, select [Transfer to PLC] to display the [Transfer Program] dialog box.
- (12) Check [Unit setting info] and [Program], and then click [Execute]. The setting information is transferred.

This completes the setting of the External Device.

3.5 Setting Example 5

■ GP-Pro EX Settings

To display the setup screen, from the [Project] menu, point to [System Settings] and select [Device/PLC].

◆ Device Setting

To display the [Individual Device Settings] dialog box, from [Device-Specific Settings] in the [Device/PLC] window, select the external device and click [Settings] .

■ External Device Settings

Use the KEYENCE Corporation ladder software (KV STUDIO Ver. 4 or later) to configure communication settings for the External Device.

Refer to your External Device manual for details.

- (1) Start up the ladder software.
- (2) From the [File] menu, select [New Project] and display the [New Project] dialog box.
- (3) Type a project name in [Project Name], select the External Device to use under [PLC model], and click [OK].
- (4) Click [Yes] in the [Confirm unit setting information] dialog box and display the [Unit Editor] window.
- (5) Select "KV-L20R" from the displayed unit list on the [Select unit] tab, and drag & drop it to the unit placement area.
- (6) Double-click "KV-L20R" in the unit placement area.
- (7) Configure the following communication settings on the [Setup unit] tab.

Setup Items		Setup Description
Port 2	Operation Mode	KV BUILDER/KV STUDIO mode
	Interface	RS-232C
	Baud Rate	Auto
	Data Bit Length	8 bits
	Start Bit	1 bit
	Stop Bit	1 bit
	Parity	Even
	Check Sum	None
Station No.	Station No.	0
Detail Settings	Transfer Timeout (sec.)	3

- (8) From the [Convert] menu, select [Auto-assign relay/DM].
- (9) From the [File] menu, select [Close] and display the [Unit Editor] dialog box.
- (10) Click [Yes].
- (11) From the [Monitor/Simulator] menu, select [Transfer to PLC] to display the [Transfer Program] dialog box.
- (12) Check [Unit setting info] and [Program], and then click [Execute]. The setting information is transferred.

This completes the setting of the External Device.

3.6 Setting Example 6

■ GP-Pro EX Settings

To display the setup screen, from the [Project] menu, point to [System Settings] and select [Device/PLC].

◆ Device Setting

To display the [Individual Device Settings] dialog box, from [Device-Specific Settings] in the [Device/PLC] window, select the external device and click [Settings] .

■ External Device Settings

Use the KEYENCE Corporation ladder software (KV STUDIO Ver. 4 or later) to configure communication settings for the External Device.

Refer to your External Device manual for details.

- (1) Start up the ladder software.
- (2) From the [File] menu, select [New Project] and display the [New Project] dialog box.
- (3) Type a project name in [Project Name], select the External Device to use under [PLC model], and click [OK].
- (4) Click [Yes] in the [Confirm unit setting information] dialog box and display the [Unit Editor] window.
- (5) Select "KV-L20" from the displayed unit list on the [Select unit] tab, and drag & drop it to the unit placement area.
- (6) Double-click "KV-L20" in the unit placement area.
- (7) Configure the following communication settings on the [Setup unit] tab.

Setup Items		Setup Description
Port 2	Operation Mode	KV BUILDER mode
	Interface	RS-422A
	Station No.	0
	Baud Rate	Auto
	Data Bit Length	8 bits
	Start Bit	1 bit
	Stop Bit	1 bit
	Parity	Even
	Check Sum	None

- (8) From the [Convert] menu, select [Auto-assign relay/DM].
- (9) From the [File] menu, select [Close] and display the [Unit Editor] dialog box.
- (10) Click [Yes].
- (11) From the [Monitor/Simulator] menu, select [Transfer to PLC] to display the [Transfer Program] dialog box.
- (12) Check [Unit setting info] and [Program], and then click [Execute]. The setting information is transferred.

This completes the setting of the External Device.

3.7 Setting Example 7

■ GP-Pro EX Settings

To display the setup screen, from the [Project] menu, point to [System Settings] and select [Device/PLC].

Device/PLC 1

Summary [Change Device/PLC](#)

Manufacturer Series Port

Text Data Mode [Change](#)

Communication Settings

SIO Type RS232C RS422/485(2wire) RS422/485(4wire)

Speed

Data Length 7 8

Parity NONE EVEN ODD

Stop Bit 1 2

Flow Control NONE ER(DTR/CTS) XON/XOFF

Timeout (sec)

Retry

Wait To Send (ms)

RI / VCC RI VCC

In the case of RS232C, you can select the 9th pin to RI (Input) or VCC (5V Power Supply). If you use the Digital's RS232C Isolation Unit, please select it to VCC.

Device-Specific Settings

Allowable Number of Devices/PLCs

No.	Device Name	Settings
<input type="button" value="x"/> 1	<input type="text" value="PLC1"/>	<input type="text" value="Series=KV-700/1000"/>

◆ Device Setting

To display the [Individual Device Settings] dialog box, from [Device-Specific Settings] in the [Device/PLC] window, select the external device and click [Settings] .

Individual Device Settings

PLC1

Series

Please reconfirm all of address settings that you are using if you have changed the series

■ External Device Settings

Use the KEYENCE Corporation ladder software (KV STUDIO Ver. 4 or later) to configure communication settings for the External Device.

Refer to your External Device manual for details.

- (1) Start up the ladder software.
- (2) From the [File] menu, select [New Project] and display the [New Project] dialog box.
- (3) Type a project name in [Project Name], select the External Device to use under [PLC model], and click [OK].
- (4) Click [Yes] in the [Confirm unit setting information] dialog box and display the [Unit Editor] window.
- (5) Select "KV-L20R" from the displayed unit list on the [Select unit] tab, and drag & drop it to the unit placement area.
- (6) Double-click "KV-L20R" in the unit placement area.
- (7) Configure the following communication settings on the [Setup unit] tab.

Setup Items		Setup Description
Port 2	Operation Mode	KV BUILDER/KV STUDIO mode
	Interface	RS-422A/485 (4wire)
	Baud Rate	Auto
	Data Bit Length	8 bits
	Start Bit	1 bit
	Stop Bit	1 bit
	Parity	Even
	Check Sum	None
Station No.	Station No.	0
Detail Settings	Transfer Timeout (sec.)	3

- (8) From the [Convert] menu, select [Auto-assign relay/DM].
- (9) From the [File] menu, select [Close] and display the [Unit Editor] dialog box.
- (10) Click [Yes].
- (11) From the [Monitor/Simulator] menu, select [Transfer to PLC] to display the [Transfer Program] dialog box.
- (12) Check [Unit setting info] and [Program], and then click [Execute]. The setting information is transferred.

This completes the setting of the External Device.

3.8 Setting Example 8

■ GP-Pro EX Settings

To display the setup screen, from the [Project] menu, point to [System Settings] and select [Device/PLC].

Device/PLC 1

Summary [Change Device/PLC](#)

Manufacturer Series Port

Text Data Mode [Change](#)

Communication Settings

SIO Type RS232C RS422/485(2wire) RS422/485(4wire)

Speed

Data Length 7 8

Parity NONE EVEN ODD

Stop Bit 1 2

Flow Control NONE ER(DTR/CTS) XON/XOFF

Timeout (sec)

Retry

Wait To Send (ms)

RI / VCC RI VCC

In the case of RS232C, you can select the 9th pin to RI (Input) or VCC (5V Power Supply). If you use the Digital's RS232C Isolation Unit, please select it to VCC.

Device-Specific Settings

Allowable Number of Devices/PLCs

No.	Device Name	Settings
<input type="button" value="x"/> 1	<input type="text" value="PLC1"/>	<input type="text" value="Series=KV-700/1000"/>

◆ Device Setting

To display the [Individual Device Settings] dialog box, from [Device-Specific Settings] in the [Device/PLC] window, select the external device and click [Settings] .

Individual Device Settings

PLC1

Series

Please reconfirm all of address settings that you are using if you have changed the series

■ External Device Settings

Use the KEYENCE Corporation ladder software (KV STUDIO Ver. 4 or later) to configure communication settings for the External Device.

Refer to your External Device manual for details.

- (1) Start up the ladder software.
- (2) From the [File] menu, select [New Project] and display the [New Project] dialog box.
- (3) Type a project name in [Project Name], select the External Device to use under [PLC model], and click [OK].
- (4) Click [Yes] in the [Confirm unit setting information] dialog box and display the [Unit Editor] window.
- (5) Select "KV-L20V" from the displayed unit list on the [Select unit] tab, and drag & drop it to the unit placement area.
- (6) Double-click "KV-L20V" in the unit placement area.
- (7) Configure the following communication settings on the [Setup unit] tab.

Setup Items		Setup Description
Port 1	Operation Mode	KV BUILDER/KV STUDIO mode
	Interface	RS-232C
	Baud Rate	Auto
	Data Bit Length	8 bits
	Start Bit	1 bit
	Stop Bit	1 bit
	Parity	Even
	Check Sum	None
	RS/CS Flow Control	Disabled
Station No.	Station No.	0
Detail Settings	Transfer Timeout (sec.)	3

- (8) From the [Convert] menu, select [Auto-assign relay/DM].
- (9) From the [File] menu, select [Close] and display the [Unit Editor] dialog box.
- (10) Click [Yes].
- (11) From the [Monitor/Simulator] menu, select [Transfer to PLC] to display the [Transfer Program] dialog box.
- (12) Check [Unit setting info] and [Program], and then click [Execute]. The setting information is transferred.

This completes the setting of the External Device.

3.9 Setting Example 9

■ SGP-Pro EX Settings

To display the setup screen, from the [Project] menu, point to [System Settings] and select [Device/PLC].

Device/PLC 1

Summary [Change Device/PLC](#)

Manufacturer Series Port

Text Data Mode [Change](#)

Communication Settings

SIO Type RS232C RS422/485(2wire) RS422/485(4wire)

Speed

Data Length 7 8

Parity NONE EVEN ODD

Stop Bit 1 2

Flow Control NONE ER(DTR/CTS) XON/XOFF

Timeout (sec)

Retry

Wait To Send (ms)

RI / VCC RI VCC

In the case of RS232C, you can select the 9th pin to RI (Input) or VCC (5V Power Supply). If you use the Digital's RS232C Isolation Unit, please select it to VCC.

Device-Specific Settings

Allowable Number of Devices/PLCs

No.	Device Name	Settings
<input type="button" value="1"/>	<input type="text" value="PLC1"/>	<input type="text" value="Series=KV-700/1000"/>

◆ Device Setting

To display the [Individual Device Settings] dialog box, from [Device-Specific Settings] in the [Device/PLC] window, select the external device and click [Settings] .

Individual Device Settings

PLC1

Series

Please reconfirm all of address settings that you are using if you have changed the series

■ External Device Settings

Use the KEYENCE Corporation ladder software (KV STUDIO Ver. 4 or later) to configure communication settings for the External Device.

Refer to your External Device manual for details.

- (1) Start up the ladder software.
- (2) From the [File] menu, select [New Project] and display the [New Project] dialog box.
- (3) Type a project name in [Project Name], select the External Device to use under [PLC model], and click [OK].
- (4) Click [Yes] in the [Confirm unit setting information] dialog box and display the [Unit Editor] window.
- (5) Select "KV-L20V" from the displayed unit list on the [Select unit] tab, and drag & drop it to the unit placement area.
- (6) Double-click "KV-L20V" in the unit placement area.
- (7) Configure the following communication settings on the [Setup unit] tab.

Setup Items		Setup Description
Port 2	Operation Mode	KV BUILDER/KV STUDIO mode
	Interface	RS-232C
	Baud Rate	Auto
	Data Bit Length	8 bits
	Start Bit	1 bit
	Stop Bit	1 bit
	Parity	Even
	Check Sum	None
Station No.	Station No.	0
Detail Settings	Transfer Timeout (sec.)	3

- (8) From the [Convert] menu, select [Auto-assign relay/DM].
- (9) From the [File] menu, select [Close] and display the [Unit Editor] dialog box.
- (10) Click [Yes].
- (11) From the [Monitor/Simulator] menu, select [Transfer to PLC] to display the [Transfer Program] dialog box.
- (12) Check [Unit setting info] and [Program], and then click [Execute]. The setting information is transferred.

This completes the setting of the External Device.

3.10 Setting Example 10

■ GP-Pro EX Settings

To display the setup screen, from the [Project] menu, point to [System Settings] and select [Device/PLC].

◆ Device Setting

To display the [Individual Device Settings] dialog box, from [Device-Specific Settings] in the [Device/PLC] window, select the external device and click [Settings] .

■ External Device Settings

Use the KEYENCE Corporation ladder software (KV STUDIO Ver. 4 or later) to configure communication settings for the External Device.

Refer to your External Device manual for details.

- (1) Start up the ladder software.
- (2) From the [File] menu, select [New Project] and display the [New Project] dialog box.
- (3) Type a project name in [Project Name], select the External Device to use under [PLC model], and click [OK].
- (4) Click [Yes] in the [Confirm unit setting information] dialog box and display the [Unit Editor] window.
- (5) Select "KV-L20V" from the displayed unit list on the [Select unit] tab, and drag & drop it to the unit placement area.
- (6) Double-click "KV-L20V" in the unit placement area.
- (7) Configure the following communication settings on the [Setup unit] tab.

Setup Items		Setup Description
Port 2	Operation Mode	KV BUILDER/KV STUDIO mode
	Interface	RS-422A/485 (4wire)
	Baud Rate	Auto
	Data Bit Length	8 bits
	Start Bit	1 bit
	Stop Bit	1 bit
	Parity	Even
	Check Sum	None
Station No.	Station No.	0
Detail Settings	Transfer Timeout (sec.)	3

- (8) From the [Convert] menu, select [Auto-assign relay/DM].
- (9) From the [File] menu, select [Close] and display the [Unit Editor] dialog box.
- (10) Click [Yes].
- (11) From the [Monitor/Simulator] menu, select [Transfer to PLC] to display the [Transfer Program] dialog box.
- (12) Check [Unit setting info] and [Program], and then click [Execute]. The setting information is transferred.

This completes the setting of the External Device.

3.11 Setting Example 11

■ GP-Pro EX Settings

To display the setup screen, from the [Project] menu, point to [System Settings] and select [Device/PLC].

◆ Device Setting

To display the [Individual Device Settings] dialog box, from [Device-Specific Settings] in the [Device/PLC] window, select the external device and click [Settings] .

■ External Device Settings

There are no settings on the External Device. The speed automatically switches according to the Display setting.

3.12 Setting Example 12

■ GP-Pro EX Settings

To display the setup screen, from the [Project] menu, point to [System Settings] and select [Device/PLC].

Device/PLC 1 [Change Device/PLC](#)

Summary
 Manufacturer: KEYENCE Corporation Series: KV-700 - 8000 SIO Port: COM1

Text Data Mode: 2 [Change](#)

Communication Settings

SIO Type: RS232C RS422/485(2wire) RS422/485(4wire)

Speed: 19200

Data Length: 7 8

Parity: NONE EVEN ODD

Stop Bit: 1 2

Flow Control: NONE ER(DTR/CTS) XON/XOFF

Timeout: 3 (sec)

Retry: 2

Wait To Send: 0 (ms)

RI / VCC: RI VCC
 In the case of RS232C, you can select the 9th pin to RI (Input) or VCC (5V Power Supply). If you use the Digital's RS232C Isolation Unit, please select it to VCC.

Default

Device-Specific Settings

Allowable Number of Devices/PLCs: 1 Add Device

No.	Device Name	Settings
1	PLC1	Series=KV-3000/5000

Add Indirect Device

◆ Device Setting

To display the [Individual Device Settings] dialog box, from [Device-Specific Settings] in the [Device/PLC] window, select the external device and click [Settings] .

Individual Device Settings

PLC1

Series: KV-3000/5000

Please reconfirm all of address settings that you are using if you have changed the series

Default

OK (O) Cancel

■ External Device Settings

Use the KEYENCE Corporation ladder software (KV STUDIO Ver. 4 or later) to configure communication settings for the External Device.

Refer to your External Device manual for details.

- (1) Start up the ladder software.
- (2) From the [File] menu, select [New Project] and display the [New Project] dialog box.
- (3) Type a project name in [Project Name], select the External Device to use under [PLC model], and click [OK].
- (4) Click [Yes] in the [Confirm unit setting information] dialog box and display the [Unit Editor] window.
- (5) Select "KV-L20V" from the displayed unit list on the [Select unit] tab, and drag & drop it to the unit placement area.
- (6) Double-click "KV-L20V" in the unit placement area.
- (7) Configure the following communication settings on the [Setup unit] tab.

Setup Items		Setup Description
Port 1	Operation Mode	KV BUILDER/KV STUDIO mode
	Interface	RS-232C
	Baud Rate	Auto
	Data Bit Length	8 bits
	Start Bit	1 bit
	Stop Bit	1 bit
	Parity	Even
	Check Sum	None
	RS/CS Flow Control	Disabled
Station No.	Station No.	0
Detail Settings	Transfer Timeout (sec.)	3

- (8) From the [Convert] menu, select [Auto-assign relay/DM].
- (9) From the [File] menu, select [Close] and display the [Unit Editor] dialog box.
- (10) Click [Yes].
- (11) From the [Monitor/Simulator] menu, select [Transfer to PLC] to display the [Transfer Program] dialog box.
- (12) Check [Unit setting info] and [Program], and then click [Execute]. The setting information is transferred.

This completes the setting of the External Device.

3.13 Setting Example 13

■ GP-Pro EX Settings

To display the setup screen, from the [Project] menu, point to [System Settings] and select [Device/PLC].

Device/PLC 1

Summary [Change Device/PLC](#)

Manufacturer Series Port

Text Data Mode [Change](#)

Communication Settings

SIO Type RS232C RS422/485(2wire) RS422/485(4wire)

Speed

Data Length 7 8

Parity NONE EVEN ODD

Stop Bit 1 2

Flow Control NONE ER(DTR/CTS) XON/XOFF

Timeout (sec)

Retry

Wait To Send (ms)

RI / VCC RI VCC
In the case of RS232C, you can select the 9th pin to RI (Input) or VCC (5V Power Supply). If you use the Digital's RS232C Isolation Unit, please select it to VCC.

Device-Specific Settings

Allowable Number of Devices/PLCs

No.	Device Name	Settings
<input type="button" value="x"/> 1	<input type="text" value="PLC1"/>	<input type="text" value="Series=KV-3000/5000"/>

◆ Device Setting

To display the [Individual Device Settings] dialog box, from [Device-Specific Settings] in the [Device/PLC] window, select the external device and click [Settings] .

Individual Device Settings

PLC1

Series

Please reconfirm all of address settings that you are using if you have changed the series

■ External Device Settings

Use the KEYENCE Corporation ladder software (KV STUDIO Ver. 4 or later) to configure communication settings for the External Device.

Refer to your External Device manual for details.

- (1) Start up the ladder software.
- (2) From the [File] menu, select [New Project] and display the [New Project] dialog box.
- (3) Type a project name in [Project Name], select the External Device to use under [PLC model], and click [OK].
- (4) Click [Yes] in the [Confirm unit setting information] dialog box and display the [Unit Editor] window.
- (5) Select "KV-L20V" from the displayed unit list on the [Select unit] tab, and drag & drop it to the unit placement area.
- (6) Double-click "KV-L20V" in the unit placement area.
- (7) Configure the following communication settings on the [Setup unit] tab.

Setup Items		Setup Description
Port 2	Operation Mode	KV BUILDER/KV STUDIO mode
	Interface	RS-232C
	Baud Rate	Auto
	Data Bit Length	8 bits
	Start Bit	1 bit
	Stop Bit	1 bit
	Parity	Even
	Check Sum	None
Station No.	Station No.	0
Detail Settings	Transfer Timeout (sec.)	3

- (8) From the [Convert] menu, select [Auto-assign relay/DM].
- (9) From the [File] menu, select [Close] and display the [Unit Editor] dialog box.
- (10) Click [Yes].
- (11) From the [Monitor/Simulator] menu, select [Transfer to PLC] to display the [Transfer Program] dialog box.
- (12) Check [Unit setting info] and [Program], and then click [Execute]. The setting information is transferred.

This completes the setting of the External Device.

3.14 Setting Example 14

■ GP-Pro EX Settings

To display the setup screen, from the [Project] menu, point to [System Settings] and select [Device/PLC].

◆ Device Setting

To display the [Individual Device Settings] dialog box, from [Device-Specific Settings] in the [Device/PLC] window, select the external device and click [Settings] .

■ External Device Settings

Use the KEYENCE Corporation ladder software (KV STUDIO Ver. 4 or later) to configure communication settings for the External Device.

Refer to your External Device manual for details.

- (1) Start up the ladder software.
- (2) From the [File] menu, select [New Project] and display the [New Project] dialog box.
- (3) Type a project name in [Project Name], select the External Device to use under [PLC model], and click [OK].
- (4) Click [Yes] in the [Confirm unit setting information] dialog box and display the [Unit Editor] window.
- (5) Select "KV-L20V" from the displayed unit list on the [Select unit] tab, and drag & drop it to the unit placement area.
- (6) Double-click "KV-L20V" in the unit placement area.
- (7) Configure the following communication settings on the [Setup unit] tab.

Setup Items		Setup Description
Port 2	Operation Mode	KV BUILDER/KV STUDIO mode
	Interface	RS-422A/485 (4wire)
	Baud Rate	Auto
	Data Bit Length	8 bits
	Start Bit	1 bit
	Stop Bit	1 bit
	Parity	Even
	Check Sum	None
Station No.	Station No.	0
Detail Settings	Transfer Timeout (sec.)	3

- (8) From the [Convert] menu, select [Auto-assign relay/DM].
- (9) From the [File] menu, select [Close] and display the [Unit Editor] dialog box.
- (10) Click [Yes].
- (11) From the [Monitor/Simulator] menu, select [Transfer to PLC] to display the [Transfer Program] dialog box.
- (12) Check [Unit setting info] and [Program], and then click [Execute]. The setting information is transferred.

This completes the setting of the External Device.

3.15 Setting Example 15

■ GP-Pro EX Settings

To display the setup screen, from the [Project] menu, point to [System Settings] and select [Device/PLC].

◆ Device Setting

To display the [Individual Device Settings] dialog box, from [Device-Specific Settings] in the [Device/PLC] window, select the external device and click [Settings] .

◆ Note

- If you are using a KV-5500 series device, select [KV-3000/5000] from the [Series] list.

■ External Device Settings

Use ladder software KV STUDIO Ver. 6 or later to define the External Device communication settings. Refer to your External Device manual for details.

- (1) Start up the ladder software.
- (2) From the [File] menu, select [New project] to display the [New project] dialog box.
- (3) In the [Project name] field enter the project name, in the [PLC model] property select the External Device, and click [OK].
- (4) In the [Confirm unit setting information] dialog box click [Yes], and the [Unit Editor] window will display.
- (5) On the [Select unit (1)] tab, from the displayed list of units select "KV-L20V", then drag & drop to the unit placement area.
- (6) In the unit placement area click "KV-L20V" and then select the [Setup unit (2)] tab.
- (7) Configure the setup items as follows.

Setup Items		Setup Description
Port 1	Operation Mode	KV BUILDER/KV STUDIO mode
	Interface	RS-232C (Fixed)
	Baud Rate	Auto (Fixed)
	Data Bit Length	8 bits (Fixed)
	Start Bit	1 bits (Fixed)
	Stop Bit	1 bits (Fixed)
	Parity	Even (Fixed)
	Check Sum	none (Fixed)
	RS/CS Flow Control	Disabled
Base	Node No.	0
Detail Settings	Transfer timeout time (secs)	3 (Fixed)

- (8) From the [Convert] menu, select [Auto-assign relay/DM].
- (9) From the [File] menu, select [Close] and display the [Unit Editor] dialog box.
- (10) Click [Yes].
- (11) From the [Monitor/Simulator] menu, select [Transfer to PLC] to display the [Transfer Program] dialog box.
- (12) Select the [Unit setting info] and [Program] check boxes, and then click [Execute]. The settings are transferred.

This completes the setting of the External Device.

3.16 Setting Example 16

■ GP-Pro EX Settings

To display the setup screen, from the [Project] menu, point to [System Settings] and select [Device/PLC].

◆ Device Setting

To display the [Individual Device Settings] dialog box, from [Device-Specific Settings] in the [Device/PLC] window, select the external device and click [Settings] .

◆ Note

- If you are using a KV-5500 series device, select [KV-3000/5000] from the [Series] list.

■ External Device Settings

Use ladder software KV STUDIO Ver. 6 or later to define the External Device communication settings. Refer to your External Device manual for details.

- (1) Start up the ladder software.
- (2) From the [File] menu, select [New project] to display the [New project] dialog box.
- (3) In the [Project name] field enter the project name, in the [PLC model] property select the External Device, and click [OK].
- (4) In the [Confirm unit setting information] dialog box click [Yes], and the [Unit Editor] window will display.
- (5) On the [Select unit (1)] tab, from the displayed list of units select "KV-L20V", then drag & drop to the unit placement area.
- (6) In the unit placement area click "KV-L20V" and then select the [Setup unit (2)] tab.
- (7) Configure the setup items as follows.

Setup Items		Setup Description
Port 2	Operation Mode	KV BUILDER/KV STUDIO mode
	Interface	RS-232C
	Baud Rate	Auto (Fixed)
	Data Bit Length	8 bits (Fixed)
	Start Bit	1 bits (Fixed)
	Stop Bit	1 bits (Fixed)
	Parity	Even (Fixed)
	Check Sum	none (Fixed)
Base	Node No.	0
Detail Settings	Transfer timeout time (secs)	3 (Fixed)

- (8) From the [Convert] menu, select [Auto-assign relay/DM].
- (9) From the [File] menu, select [Close] and display the [Unit Editor] dialog box.
- (10) Click [Yes].
- (11) From the [Monitor/Simulator] menu, select [Transfer to PLC] to display the [Transfer Program] dialog box.
- (12) Select the [Unit setting info] and [Program] check boxes, and then click [Execute]. The settings are transferred.

This completes the setting of the External Device.

3.17 Setting Example 17

■ GP-Pro EX Settings

To display the setup screen, from the [Project] menu, point to [System Settings] and select [Device/PLC].

◆ Device Setting

To display the [Individual Device Settings] dialog box, from [Device-Specific Settings] in the [Device/PLC] window, select the external device and click [Settings] .

◆ Note

- If you are using a KV-5500 series device, select [KV-3000/5000] from the [Series] list.

■ External Device Settings

Use ladder software KV STUDIO Ver. 6 or later to define the External Device communication settings. Refer to your External Device manual for details.

- (1) Start up the ladder software.
- (2) From the [File] menu, select [New project] to display the [New project] dialog box.
- (3) In the [Project name] field enter the project name, in the [PLC model] property select the External Device, and click [OK].
- (4) In the [Confirm unit setting information] dialog box click [Yes], and the [Unit Editor] window will display.
- (5) On the [Select unit (1)] tab, from the displayed list of units select "KV-L20V", then drag & drop to the unit placement area.
- (6) In the unit placement area click "KV-L20V" and then select the [Setup unit (2)] tab.
- (7) Configure the setup items as follows.

Setup Items		Setup Description
Port 2	Operation Mode	KV BUILDER/KV STUDIO mode
	Interface	RS-422A/485 (4wire)
	Baud Rate	Auto (Fixed)
	Data Bit Length	8 bits (Fixed)
	Start Bit	1 bits (Fixed)
	Stop Bit	1 bits (Fixed)
	Parity	Even (Fixed)
	Check Sum	none (Fixed)
Base	Node No.	0
Detail Settings	Transfer timeout time (secs)	3 (Fixed)

- (8) From the [Convert] menu, select [Auto-assign relay/DM].
- (9) From the [File] menu, select [Close] and display the [Unit Editor] dialog box.
- (10) Click [Yes].
- (11) From the [Monitor/Simulator] menu, select [Transfer to PLC] to display the [Transfer Program] dialog box.
- (12) Select the [Unit setting info] and [Program] check boxes, and then click [Execute]. The settings are transferred.

This completes the setting of the External Device.

3.18 Setting Example 18

■ GP-Pro EX Settings

To display the setup screen, from the [Project] menu, point to [System Settings] and select [Device/PLC].

Device/PLC 1

Summary [Change Device/PLC](#)

Manufacturer Series Port

Text Data Mode [Change](#)

Communication Settings

SIO Type RS232C RS422/485(2wire) RS422/485(4wire)

Speed

Data Length 7 8

Parity NONE EVEN ODD

Stop Bit 1 2

Flow Control NONE ER(DTR/CTS) XON/XOFF

Timeout (sec)

Retry

Wait To Send (ms)

RI / VCC RI VCC

In the case of RS232C, you can select the 9th pin to RI (Input) or VCC (5V Power Supply). If you use the Digital's RS232C Isolation Unit, please select it to VCC.

Device-Specific Settings

Allowable Number of Devices/PLCs

No.	Device Name	Settings
<input type="button" value="1"/>	<input type="text" value="PLC1"/>	<input type="text" value="Series=KV-Nano"/>

◆ Device Setting

To display the [Individual Device Settings] dialog box, from [Device-Specific Settings] in the [Device/PLC] window, select the external device and click [Settings] .

Individual Device Settings

PLC1

Series

Please reconfirm all of address settings that you are using if you have changed the series

■ External Device Settings

Use ladder software KV STUDIO Ver. 8 or later to define the External Device communication settings. Refer to your External Device manual for details.

- (1) Start up the ladder software.
- (2) From the [File] menu, select [New project] to display the [New project] dialog box.
- (3) In the [Project name] field enter the project name, in the [PLC model] property select the External Device, and click [OK].
- (4) In the [Confirm unit setting information] dialog box click [Yes], and the [Unit Editor] window will display.
- (5) Select the [Setup unit (2)] tab.
- (6) Configure the setup items as follows.

Setup Items		Setup Description
Built-in serial	Operation Mode	KV STUDIO mode

- (7) From the [File] menu, select [Close] and display the [Unit Editor] dialog box.
- (8) Click [Yes].
- (9) From the [Monitor/Simulator] menu, select [Transfer to PLC] to display the [Transfer Program] dialog box.
- (10) Select the [Unit setting info] and [Program] check boxes, and then click [Execute]. The settings are transferred.

This completes the setting of the External Device.

3.19 Setting Example 19

■ GP-Pro EX Settings

To display the setup screen, from the [Project] menu, point to [System Settings] and select [Device/PLC].

Device/PLC 1

Summary [Change Device/PLC](#)

Manufacturer Series Port

Text Data Mode [Change](#)

Communication Settings

SIO Type RS232C RS422/485(2wire) RS422/485(4wire)

Speed

Data Length 7 8

Parity NONE EVEN ODD

Stop Bit 1 2

Flow Control NONE ER(DTR/CTS) XON/XOFF

Timeout (sec)

Retry

Wait To Send (ms)

RI / VCC RI VCC

In the case of RS232C, you can select the 9th pin to RI (Input) or VCC (5V Power Supply). If you use the Digital's RS232C Isolation Unit, please select it to VCC.

Default

Device-Specific Settings

Allowable Number of Devices/PLCs 1 [Add Device](#)

No.	Device Name	Settings
1	<input type="text" value="PLC1"/>	<input type="text" value="Series=KV-7000"/>

[Add Indirect Device](#)

◆ Device Setting

To display the [Individual Device Settings] dialog box, from [Device-Specific Settings] in the [Device/PLC] window, select the external device and click [Settings] .

Individual Device Settings

PLC1

Series

Please reconfirm all of address settings that you are using if you have changed the series

Default

OK (O) Cancel

■ External Device Settings

Use ladder software KV STUDIO Ver. 8 or later to define the External Device communication settings. Refer to your External Device manual for details.

- (1) Start up the ladder software.
- (2) From the [File] menu, select [New project] to display the [New project] dialog box.
- (3) In the [Project name] field enter the project name, in the [PLC model] property select the External Device, and click [OK].
- (4) In the [Confirm unit setting information] dialog box click [Yes], and the [Unit Editor] window will display.
- (5) Select the [Setup unit (2)] tab.
- (6) Configure the setup items as follows.

Setup Items		Setup Description
Built-in serial	Operation Mode	KV STUDIO mode

- (7) From the [File] menu, select [Close] and display the [Unit Editor] dialog box.
- (8) Click [Yes].
- (9) From the [Monitor/Simulator] menu, select [Transfer to PLC] to display the [Transfer Program] dialog box.
- (10) Select the [Unit setting info] and [Program] check boxes, and then click [Execute]. The settings are transferred.

This completes the setting of the External Device.

3.20 Setting Example 20

■ GP-Pro EX Settings

To display the setup screen, from the [Project] menu, point to [System Settings] and select [Device/PLC].

Device/PLC 1

Summary [Change Device/PLC](#)

Manufacturer Series Port

Text Data Mode [Change](#)

Communication Settings

SIO Type RS232C RS422/485(2wire) RS422/485(4wire)

Speed ▾

Data Length 7 8

Parity NONE EVEN ODD

Stop Bit 1 2

Flow Control NONE ER(DTR/CTS) XON/XOFF

Timeout (sec)

Retry

Wait To Send (ms)

RI / VCC RI VCC
In the case of RS232C, you can select the 9th pin to RI (Input or VCC (5V Power Supply)). If you use the Digital's RS232C Isolation Unit, please select it to VCC.

Device-Specific Settings

Allowable Number of Devices/PLCs

No.	Device Name	Settings
<input type="button" value="1"/>	<input type="text" value="PLC1"/>	<input type="text" value="Series=KV-7000"/> <input type="button" value="Settings"/>

◆ Device Setting

To display the [Individual Device Settings] dialog box, from [Device-Specific Settings] in the [Device/PLC] window, select the external device and click [Settings] .

Individual Device Settings

PLC1

Series ▾

Please reconfirm all of address settings that you are using if you have changed the series

■ External Device Settings

Use ladder software KV STUDIO Ver. 8 or later to define the External Device communication settings. Refer to your External Device manual for details.

- (1) Start up the ladder software.
- (2) From the [File] menu, select [New project] to display the [New project] dialog box.
- (3) In the [Project name] field enter the project name, in the [PLC model] property select the External Device, and click [OK].
- (4) In the [Confirm unit setting information] dialog box click [Yes], and the [Unit Editor] window will display.
- (5) On the [Select unit (1)] tab, from the displayed list of units select "KV-L20V", then drag & drop to the unit placement area.
- (6) In the unit placement area click "KV-L20V" and then select the [Setup unit (2)] tab.
- (7) Configure the setup items as follows.

Setup Items		Setup Description
Port 1	Operation Mode	KV BUILDER/KV STUDIO mode
	Interface	RS-232C (Fixed)
	Baud Rate	Auto (Fixed)
	Data Bit Length	8 bits (Fixed)
	Start Bit	1 bits (Fixed)
	Stop Bit	1 bits (Fixed)
	Parity	Even (Fixed)
	Check Sum	none (Fixed)
	RS/CS Flow Control	Disabled
Base	Node No.	0
Detail Settings	Transfer timeout time (secs)	3 (Fixed)

- (8) From the [Convert] menu, select [Auto-assign relay/DM].
- (9) From the [File] menu, select [Close] and display the [Unit Editor] dialog box.
- (10) Click [Yes].
- (11) From the [Monitor/Simulator] menu, select [Transfer to PLC] to display the [Transfer Program] dialog box.
- (12) Select the [Unit setting info] and [Program] check boxes, and then click [Execute]. The settings are transferred.

This completes the setting of the External Device.

3.21 Setting Example 21

■ GP-Pro EX Settings

To display the setup screen, from the [Project] menu, point to [System Settings] and select [Device/PLC].

Device/PLC 1

Summary [Change Device/PLC](#)

Manufacturer Series Port

Text Data Mode [Change](#)

Communication Settings

SIO Type RS232C RS422/485(2wire) RS422/485(4wire)

Speed

Data Length 7 8

Parity NONE EVEN ODD

Stop Bit 1 2

Flow Control NONE ER(DTR/CTS) XON/XOFF

Timeout (sec)

Retry

Wait To Send (ms)

RI / VCC RI VCC
 In the case of RS232C, you can select the 9th pin to RI (Input) or VCC (5V Power Supply). If you use the Digital's RS232C Isolation Unit, please select it to VCC.

Device-Specific Settings

Allowable Number of Devices/PLCs

No.	Device Name	Settings
1	<input type="text" value="PLC1"/>	<input type="text" value="Series=KV-7000"/>

◆ Device Setting

To display the [Individual Device Settings] dialog box, from [Device-Specific Settings] in the [Device/PLC] window, select the external device and click [Settings] .

Individual Device Settings

PLC1

Series

Please reconfirm all of address settings that you are using if you have changed the series

■ External Device Settings

Use ladder software KV STUDIO Ver. 8 or later to define the External Device communication settings. Refer to your External Device manual for details.

- (1) Start up the ladder software.
- (2) From the [File] menu, select [New project] to display the [New project] dialog box.
- (3) In the [Project name] field enter the project name, in the [PLC model] property select the External Device, and click [OK].
- (4) In the [Confirm unit setting information] dialog box click [Yes], and the [Unit Editor] window will display.
- (5) On the [Select unit (1)] tab, from the displayed list of units select "KV-L20V", then drag & drop to the unit placement area.
- (6) In the unit placement area click "KV-L20V" and then select the [Setup unit (2)] tab.
- (7) Configure the setup items as follows.

Setup Items		Setup Description
Port 2	Operation Mode	KV BUILDER/KV STUDIO mode
	Interface	RS-232C
	Baud Rate	Auto (Fixed)
	Data Bit Length	8 bits (Fixed)
	Start Bit	1 bits (Fixed)
	Stop Bit	1 bits (Fixed)
	Parity	Even (Fixed)
	Check Sum	none (Fixed)
Base	Node No.	0
Detail Settings	Transfer timeout time (secs)	3 (Fixed)

- (8) From the [Convert] menu, select [Auto-assign relay/DM].
- (9) From the [File] menu, select [Close] and display the [Unit Editor] dialog box.
- (10) Click [Yes].
- (11) From the [Monitor/Simulator] menu, select [Transfer to PLC] to display the [Transfer Program] dialog box.
- (12) Select the [Unit setting info] and [Program] check boxes, and then click [Execute]. The settings are transferred.

This completes the setting of the External Device.

3.22 Setting Example 22

■ GP-Pro EX Settings

To display the setup screen, from the [Project] menu, point to [System Settings] and select [Device/PLC].

◆ Device Setting

To display the [Individual Device Settings] dialog box, from [Device-Specific Settings] in the [Device/PLC] window, select the external device and click [Settings] .

■ External Device Settings

Use ladder software KV STUDIO Ver. 8 or later to define the External Device communication settings. Refer to your External Device manual for details.

- (1) Start up the ladder software.
- (2) From the [File] menu, select [New project] to display the [New project] dialog box.
- (3) In the [Project name] field enter the project name, in the [PLC model] property select the External Device, and click [OK].
- (4) In the [Confirm unit setting information] dialog box click [Yes], and the [Unit Editor] window will display.
- (5) On the [Select unit (1)] tab, from the displayed list of units select "KV-L20V", then drag & drop to the unit placement area.
- (6) In the unit placement area click "KV-L20V" and then select the [Setup unit (2)] tab.
- (7) Configure the setup items as follows.

Setup Items		Setup Description
Port 2	Operation Mode	KV BUILDER/KV STUDIO mode
	Interface	RS-422A/485 (4wire)
	Baud Rate	Auto (Fixed)
	Data Bit Length	8 bits (Fixed)
	Start Bit	1 bits (Fixed)
	Stop Bit	1 bits (Fixed)
	Parity	Even (Fixed)
	Check Sum	none (Fixed)
Base	Node No.	0
Detail Settings	Transfer timeout time (secs)	3 (Fixed)

- (8) From the [Convert] menu, select [Auto-assign relay/DM].
- (9) From the [File] menu, select [Close] and display the [Unit Editor] dialog box.
- (10) Click [Yes].
- (11) From the [Monitor/Simulator] menu, select [Transfer to PLC] to display the [Transfer Program] dialog box.
- (12) Select the [Unit setting info] and [Program] check boxes, and then click [Execute]. The settings are transferred.

This completes the setting of the External Device.

3.23 Setting Example 23

■ GP-Pro EX Settings

To display the setup screen, from the [Project] menu, point to [System Settings] and select [Device/PLC].

Device/PLC 1

Summary [Change Device/PLC](#)

Manufacturer Series Port

Text Data Mode [Change](#)

Communication Settings

SIO Type RS232C RS422/485(2wire) RS422/485(4wire)

Speed ▾

Data Length 7 8

Parity NONE EVEN ODD

Stop Bit 1 2

Flow Control NONE ER(DTR/CTS) XON/XOFF

Timeout (sec)

Retry

Wait To Send (ms)

RI / VCC RI VCC
In the case of RS232C, you can select the 9th pin to RI (Input) or VCC (5V Power Supply). If you use the Digital's RS232C Isolation Unit, please select it to VCC.

Device-Specific Settings

Allowable Number of Devices/PLCs

No.	Device Name	Settings
1	<input type="text" value="PLC1"/>	<input type="text" value="Series=KV-7000"/>

◆ Device Setting

To display the [Individual Device Settings] dialog box, from [Device-Specific Settings] in the [Device/PLC] window, select the external device and click [Settings] .

Individual Device Settings

PLC1

Series ▾

Please reconfirm all of address settings that you are using if you have changed the series

■ External Device Settings

Use ladder software KV STUDIO Ver. 8 or later to define the External Device communication settings. Refer to your External Device manual for details.

- (1) Start up the ladder software.
- (2) From the [File] menu, select [New project] to display the [New project] dialog box.
- (3) In the [Project name] field enter the project name, in the [PLC model] property select the External Device, and click [OK].
- (4) In the [Confirm unit setting information] dialog box click [Yes], and the [Unit Editor] window will display.
- (5) On the [Select unit (1)] tab, from the displayed list of units select "KV-L20V", then drag & drop to the unit placement area.
- (6) In the unit placement area click "KV-L20V" and then select the [Setup unit (2)] tab.
- (7) Configure the setup items as follows.

Setup Items		Setup Description
Port 2	Operation Mode	KV BUILDER/KV STUDIO mode
	Interface	RS-422A/485 (2wire)
	Baud Rate	Auto (Fixed)
	Data Bit Length	8 bits (Fixed)
	Start Bit	1 bits (Fixed)
	Stop Bit	1 bits (Fixed)
	Parity	Even (Fixed)
	Check Sum	none (Fixed)
Base	Node No.	0
Detail Settings	Transfer timeout time (secs)	3 (Fixed)

- (8) From the [Convert] menu, select [Auto-assign relay/DM].
- (9) From the [File] menu, select [Close] and display the [Unit Editor] dialog box.
- (10) Click [Yes].
- (11) From the [Monitor/Simulator] menu, select [Transfer to PLC] to display the [Transfer Program] dialog box.
- (12) Select the [Unit setting info] and [Program] check boxes, and then click [Execute]. The settings are transferred.

This completes the setting of the External Device.

3.24 Setting Example 24

■ GP-Pro EX Settings

To display the setup screen, from the [Project] menu, point to [System Settings] and select [Device/PLC].

Device/PLC 1

Summary [Change Device/PLC](#)

Manufacturer Series Port

Text Data Mode [Change](#)

Communication Settings

SIO Type RS232C RS422/485(2wire) RS422/485(4wire)

Speed

Data Length 7 8

Parity NONE EVEN ODD

Stop Bit 1 2

Flow Control NONE ER(DTR/CTS) XON/XOFF

Timeout (sec)

Retry

Wait To Send (ms)

RI / VCC RI VCC
In the case of RS232C, you can select the 9th pin to RI (Input) or VCC (5V Power Supply). If you use the Digital's RS232C Isolation Unit, please select it to VCC.

Device-Specific Settings

Allowable Number of Devices/PLCs

No.	Device Name	Settings
<input type="button" value="1"/>	<input type="text" value="PLC1"/>	<input type="text" value="Series=KV-Nano"/>

◆ Device Setting

To display the [Individual Device Settings] dialog box, from [Device-Specific Settings] in the [Device/PLC] window, select the external device and click [Settings] .

Individual Device Settings

PLC1

Series

Please reconfirm all of address settings that you are using if you have changed the series

■ External Device Settings

Use ladder software KV STUDIO Ver. 8 or later to define the External Device communication settings. Refer to your External Device manual for details.

- (1) Start up the ladder software.
- (2) From the [File] menu, select [New project] to display the [New project] dialog box.
- (3) In the [Project name] field enter the project name, in the [PLC model] property select the External Device, and click [OK].
- (4) In the [Confirm unit setting information] dialog box click [Yes], and the [Unit Editor] window will display.
- (5) On the [Select unit (1)] tab, from the [Extension Cassette left (Port1)] area select "KV-N10L".
- (6) Configure the setup items as follows.

Setup Items		Setup Description
Port 1	Operation Mode	KV BUILDER/KV STUDIO mode
	Interface	RS-232C (Fixed)
	Baud Rate	Auto (Fixed)
	Data Bit Length	8 bits (Fixed)
	Start Bit	1 bits (Fixed)
	Stop Bit	1 bits (Fixed)
	Parity	Even (Fixed)
	Check Sum	none (Fixed)
	RS/CS Flow Control	Disabled
Base	Node No.	0
Detail Settings	Transfer timeout time (secs)	3 (Fixed)

- (7) From the [Convert] menu, select [Auto-assign relay/DM].
- (8) From the [File] menu, select [Close] and display the [Unit Editor] dialog box.
- (9) Click [Yes].
- (10) From the [Monitor/Simulator] menu, select [Transfer to PLC] to display the [Transfer Program] dialog box.
- (11) Select the [Unit setting info] and [Program] check boxes, and then click [Execute]. The settings are transferred.

This completes the setting of the External Device.

3.25 Setting Example 25

■ GP-Pro EX Settings

To display the setup screen, from the [Project] menu, point to [System Settings] and select [Device/PLC].

Device/PLC 1

Summary [Change Device/PLC](#)

Manufacturer Series Port

Text Data Mode [Change](#)

Communication Settings

SIO Type RS232C RS422/485(2wire) RS422/485(4wire)

Speed ▾

Data Length 7 8

Parity NONE EVEN ODD

Stop Bit 1 2

Flow Control NONE ER(DTR/CTS) XON/XOFF

Timeout (sec)

Retry

Wait To Send (ms)

RI / VCC RI VCC
In the case of RS232C, you can select the 9th pin to RI (Input) or VCC (5V Power Supply). If you use the Digital's RS232C Isolation Unit, please select it to VCC.

Device-Specific Settings

Allowable Number of Devices/PLCs

No.	Device Name	Settings	<input type="button" value="Add Indirect Device"/>
1	<input type="text" value="PLC1"/>	<input type="text" value="Series=KV-Nano"/>	<input type="button" value="Add Indirect Device"/>

◆ Device Setting

To display the [Individual Device Settings] dialog box, from [Device-Specific Settings] in the [Device/PLC] window, select the external device and click [Settings] .

Individual Device Settings

PLC1

Series ▾

Please reconfirm all of address settings that you are using if you have changed the series

■ External Device Settings

Use ladder software KV STUDIO Ver. 8 or later to define the External Device communication settings. Refer to your External Device manual for details.

- (1) Start up the ladder software.
- (2) From the [File] menu, select [New project] to display the [New project] dialog box.
- (3) In the [Project name] field enter the project name, in the [PLC model] property select the External Device, and click [OK].
- (4) In the [Confirm unit setting information] dialog box click [Yes], and the [Unit Editor] window will display.
- (5) On the [Select unit (1)] tab, from the [Extension Cassette left (Port1)] area select "KV-N11L".
- (6) Configure the setup items as follows.

Setup Items		Setup Description
Port 1	Operation Mode	KV BUILDER/KV STUDIO mode
	Interface	RS-422A/485 (4wire)
	Baud Rate	Auto (Fixed)
	Data Bit Length	8 bits (Fixed)
	Start Bit	1 bits (Fixed)
	Stop Bit	1 bits (Fixed)
	Parity	Even (Fixed)
	Check Sum	none (Fixed)
	RS/CS Flow Control	Disabled
Base	Node No.	0
Detail Settings	Transfer timeout time (secs)	3 (Fixed)

- (7) From the [Convert] menu, select [Auto-assign relay/DM].
- (8) From the [File] menu, select [Close] and display the [Unit Editor] dialog box.
- (9) Click [Yes].
- (10) From the [Monitor/Simulator] menu, select [Transfer to PLC] to display the [Transfer Program] dialog box.
- (11) Select the [Unit setting info] and [Program] check boxes, and then click [Execute]. The settings are transferred.

This completes the setting of the External Device.

3.26 Setting Example 26

■ GP-Pro EX Settings

To display the setup screen, from the [Project] menu, point to [System Settings] and select [Device/PLC].

◆ Device Setting

To display the [Individual Device Settings] dialog box, from [Device-Specific Settings] in the [Device/PLC] window, select the external device and click [Settings] .

■ External Device Settings

Use ladder software KV STUDIO Ver. 8 or later to define the External Device communication settings. Refer to your External Device manual for details.

- (1) Start up the ladder software.
- (2) From the [File] menu, select [New project] to display the [New project] dialog box.
- (3) In the [Project name] field enter the project name, in the [PLC model] property select the External Device, and click [OK].
- (4) In the [Confirm unit setting information] dialog box click [Yes], and the [Unit Editor] window will display.
- (5) On the [Select unit (1)] tab, from the [Extension Cassette left (Port1)] area select "KV-N11L".
- (6) Configure the setup items as follows.

Setup Items		Setup Description
Port 1	Operation Mode	KV BUILDER/KV STUDIO mode
	Interface	RS-422A/485 (2wire)
	Baud Rate	Auto (Fixed)
	Data Bit Length	8 bits (Fixed)
	Start Bit	1 bits (Fixed)
	Stop Bit	1 bits (Fixed)
	Parity	Even (Fixed)
	Check Sum	none (Fixed)
	RS/CS Flow Control	Disabled
Base	Node No.	0
Detail Settings	Transfer timeout time (secs)	3 (Fixed)

- (7) From the [Convert] menu, select [Auto-assign relay/DM].
- (8) From the [File] menu, select [Close] and display the [Unit Editor] dialog box.
- (9) Click [Yes].
- (10) From the [Monitor/Simulator] menu, select [Transfer to PLC] to display the [Transfer Program] dialog box.
- (11) Select the [Unit setting info] and [Program] check boxes, and then click [Execute]. The settings are transferred.

This completes the setting of the External Device.

3.27 Setting Example 27

■ GP-Pro EX Settings

To display the setup screen, from the [Project] menu, point to [System Settings] and select [Device/PLC].

Device/PLC 1

Summary [Change Device/PLC](#)

Manufacturer Series Port

Text Data Mode [Change](#)

Communication Settings

SIO Type RS232C RS422/485(2wire) RS422/485(4wire)

Speed

Data Length 7 8

Parity NONE EVEN ODD

Stop Bit 1 2

Flow Control NONE ER(DTR/CTS) XON/XOFF

Timeout (sec)

Retry

Wait To Send (ms)

RI / VCC RI VCC

In the case of RS232C, you can select the 9th pin to RI (Input) or VCC (5V Power Supply). If you use the Digital's RS232C Isolation Unit, please select it to VCC.

Device-Specific Settings

Allowable Number of Devices/PLCs

No.	Device Name	Settings
1	<input type="text" value="PLC1"/>	<input type="text" value="Series=KV-Nano"/>

◆ Device Setting

To display the [Individual Device Settings] dialog box, from [Device-Specific Settings] in the [Device/PLC] window, select the external device and click [Settings] .

Individual Device Settings

PLC1

Series

Please reconfirm all of address settings that you are using if you have changed the series

■ External Device Settings

Use ladder software KV STUDIO Ver. 8 or later to define the External Device communication settings. Refer to your External Device manual for details.

- (1) Start up the ladder software.
- (2) From the [File] menu, select [New project] to display the [New project] dialog box.
- (3) In the [Project name] field enter the project name, in the [PLC model] property select the External Device, and click [OK].
- (4) In the [Confirm unit setting information] dialog box click [Yes], and the [Unit Editor] window will display.
- (5) On the [Select unit (1)] tab, from the [Extension Adapter Selection] area select "KV-NC10L".
- (6) Configure the [Extension Adapter (Port1)] as follows.

Setup Items		Setup Description
Port 1	Operation Mode	KV BUILDER/KV STUDIO mode
	Interface	RS-232C (Fixed)
	Baud Rate	Auto (Fixed)
	Data Bit Length	8 bits (Fixed)
	Start Bit	1 bits (Fixed)
	Stop Bit	1 bits (Fixed)
	Parity	Even (Fixed)
	Check Sum	none (Fixed)
	RS/CS Flow Control	Disabled
Base	Node No.	0
Detail Settings	Transfer timeout time (secs)	3 (Fixed)

- (7) From the [Convert] menu, select [Auto-assign relay/DM].
- (8) From the [File] menu, select [Close] and display the [Unit Editor] dialog box.
- (9) Click [Yes].
- (10) From the [Monitor/Simulator] menu, select [Transfer to PLC] to display the [Transfer Program] dialog box.
- (11) Select the [Unit setting info] and [Program] check boxes, and then click [Execute]. The settings are transferred.

This completes the setting of the External Device.

3.28 Setting Example 28

■ GP-Pro EX Settings

To display the setup screen, from the [Project] menu, point to [System Settings] and select [Device/PLC].

◆ Device Setting

To display the [Individual Device Settings] dialog box, from [Device-Specific Settings] in the [Device/PLC] window, select the external device and click [Settings] .

■ External Device Settings

Use ladder software KV STUDIO Ver. 8 or later to define the External Device communication settings. Refer to your External Device manual for details.

- (1) Start up the ladder software.
- (2) From the [File] menu, select [New project] to display the [New project] dialog box.
- (3) In the [Project name] field enter the project name, in the [PLC model] property select the External Device, and click [OK].
- (4) In the [Confirm unit setting information] dialog box click [Yes], and the [Unit Editor] window will display.
- (5) On the [Select unit (1)] tab, from the [Extension Adapter Selection] area select "KV-NC20L".
- (6) Configure the [Extension Adapter (Port1)] as follows.

Setup Items		Setup Description
Port 1	Operation Mode	KV BUILDER/KV STUDIO mode
	Interface	RS-232C (Fixed)
	Baud Rate	Auto (Fixed)
	Data Bit Length	8 bits (Fixed)
	Start Bit	1 bits (Fixed)
	Stop Bit	1 bits (Fixed)
	Parity	Even (Fixed)
	Check Sum	none (Fixed)
	RS/CS Flow Control	Disabled
Base	Node No.	0
Detail Settings	Transfer timeout time (secs)	3 (Fixed)

- (7) From the [Convert] menu, select [Auto-assign relay/DM].
- (8) From the [File] menu, select [Close] and display the [Unit Editor] dialog box.
- (9) Click [Yes].
- (10) From the [Monitor/Simulator] menu, select [Transfer to PLC] to display the [Transfer Program] dialog box.
- (11) Select the [Unit setting info] and [Program] check boxes, and then click [Execute]. The settings are transferred.

This completes the setting of the External Device.

3.29 Setting Example 29

■ GP-Pro EX Settings

To display the setup screen, from the [Project] menu, point to [System Settings] and select [Device/PLC].

Device/PLC 1 [Change Device/PLC](#)

Summary
 Manufacturer Series Port

Text Data Mode [Change](#)

Communication Settings

SIO Type RS232C RS422/485(2wire) RS422/485(4wire)

Speed

Data Length 7 8

Parity NONE EVEN ODD

Stop Bit 1 2

Flow Control NONE ER(DTR/CTS) XON/XOFF

Timeout (sec)

Retry

Wait To Send (ms)

RI / VCC RI VCC
 In the case of RS232C, you can select the 9th pin to RI (Input or VCC (5V Power Supply)). If you use the Digital's RS232C Isolation Unit, please select it to VCC.

Device-Specific Settings

Allowable Number of Devices/PLCs

No.	Device Name	Settings
<input type="button" value="Add"/> 1	<input type="text" value="PLC1"/>	<input type="text" value="Series=KV-Nano"/> <input type="button" value="Settings"/>

◆ Device Setting

To display the [Individual Device Settings] dialog box, from [Device-Specific Settings] in the [Device/PLC] window, select the external device and click [Settings] .

Individual Device Settings

PLC1

Series

Please reconfirm all of address settings that you are using if you have changed the series

■ External Device Settings

Use ladder software KV STUDIO Ver. 8 or later to define the External Device communication settings. Refer to your External Device manual for details.

- (1) Start up the ladder software.
- (2) From the [File] menu, select [New project] to display the [New project] dialog box.
- (3) In the [Project name] field enter the project name, in the [PLC model] property select the External Device, and click [OK].
- (4) In the [Confirm unit setting information] dialog box click [Yes], and the [Unit Editor] window will display.
- (5) On the [Select unit (1)] tab, from the [Extension Adapter Selection] area select "KV-NC20L".
- (6) Configure the [Extension Adapter (Port2)] as follows.

Setup Items		Setup Description
Port 2	Operation Mode	KV BUILDER/KV STUDIO mode
	Interface	RS-232C (Fixed)
	Baud Rate	Auto (Fixed)
	Data Bit Length	8 bits (Fixed)
	Start Bit	1 bits (Fixed)
	Stop Bit	1 bits (Fixed)
	Parity	Even (Fixed)
	Check Sum	none (Fixed)
	RS/CS Flow Control	Disabled
Base	Node No.	0
Detail Settings	Transfer timeout time (secs)	3 (Fixed)

- (7) From the [Convert] menu, select [Auto-assign relay/DM].
- (8) From the [File] menu, select [Close] and display the [Unit Editor] dialog box.
- (9) Click [Yes].
- (10) From the [Monitor/Simulator] menu, select [Transfer to PLC] to display the [Transfer Program] dialog box.
- (11) Select the [Unit setting info] and [Program] check boxes, and then click [Execute]. The settings are transferred.

This completes the setting of the External Device.

3.30 Setting Example 30

■ GP-Pro EX Settings

To display the setup screen, from the [Project] menu, point to [System Settings] and select [Device/PLC].

Device/PLC 1

Summary [Change Device/PLC](#)

Manufacturer Series Port

Text Data Mode [Change](#)

Communication Settings

SIO Type RS232C RS422/485(2wire) RS422/485(4wire)

Speed ▾

Data Length 7 8

Parity NONE EVEN ODD

Stop Bit 1 2

Flow Control NONE ER(DTR/CTS) XON/XOFF

Timeout (sec)

Retry

Wait To Send (ms)

RI / VCC RI VCC
In the case of RS232C, you can select the 9th pin to RI (Input) or VCC (5V Power Supply). If you use the Digital's RS232C Isolation Unit, please select it to VCC.

Device-Specific Settings

Allowable Number of Devices/PLCs 1

No.	Device Name	Settings	<input type="button" value="Add Indirect Device"/>
1	<input type="text" value="PLC1"/>	<input type="text" value="Series=KV-Nano"/>	<input type="button" value="Add Indirect Device"/>

◆ Device Setting

To display the [Individual Device Settings] dialog box, from [Device-Specific Settings] in the [Device/PLC] window, select the external device and click [Settings] .

Individual Device Settings

PLC1

Series ▾

Please reconfirm all of address settings that you are using if you have changed the series

■ External Device Settings

Use ladder software KV STUDIO Ver. 8 or later to define the External Device communication settings. Refer to your External Device manual for details.

- (1) Start up the ladder software.
- (2) From the [File] menu, select [New project] to display the [New project] dialog box.
- (3) In the [Project name] field enter the project name, in the [PLC model] property select the External Device, and click [OK].
- (4) In the [Confirm unit setting information] dialog box click [Yes], and the [Unit Editor] window will display.
- (5) On the [Select unit (1)] tab, from the [Extension Adapter Selection] area select "KV-NC20L".
- (6) Configure the [Extension Adapter (Port2)] as follows.

Setup Items		Setup Description
Port 2	Operation Mode	KV BUILDER/KV STUDIO mode
	Interface	RS-422A/485 (4wire)
	Baud Rate	Auto (Fixed)
	Data Bit Length	8 bits (Fixed)
	Start Bit	1 bits (Fixed)
	Stop Bit	1 bits (Fixed)
	Parity	Even (Fixed)
	Check Sum	none (Fixed)
	RS/CS Flow Control	Disabled
Base	Node No.	0
Detail Settings	Transfer timeout time (secs)	3 (Fixed)

- (7) From the [Convert] menu, select [Auto-assign relay/DM].
- (8) From the [File] menu, select [Close] and display the [Unit Editor] dialog box.
- (9) Click [Yes].
- (10) From the [Monitor/Simulator] menu, select [Transfer to PLC] to display the [Transfer Program] dialog box.
- (11) Select the [Unit setting info] and [Program] check boxes, and then click [Execute]. The settings are transferred.

This completes the setting of the External Device.

3.31 Setting Example 31

■ GP-Pro EX Settings

To display the setup screen, from the [Project] menu, point to [System Settings] and select [Device/PLC].

Device/PLC 1

Summary [Change Device/PLC](#)

Manufacturer Series Port

Text Data Mode [Change](#)

Communication Settings

SIO Type RS232C RS422/485(2wire) RS422/485(4wire)

Speed

Data Length 7 8

Parity NONE EVEN ODD

Stop Bit 1 2

Flow Control NONE ER(DTR/CTS) XON/XOFF

Timeout (sec)

Retry

Wait To Send (ms)

RI / VCC RI VCC

In the case of RS232C, you can select the 9th pin to RI (Input) or VCC (5V Power Supply). If you use the Digital's RS232C Isolation Unit, please select it to VCC.

Device-Specific Settings

Allowable Number of Devices/PLCs

No.	Device Name	Settings	<input type="button" value="Add Indirect Device"/>
1	<input type="text" value="PLC1"/>	<input type="text" value="Series=KV-Nano"/>	<input type="button" value="Add Indirect Device"/>

◆ Device Setting

To display the [Individual Device Settings] dialog box, from [Device-Specific Settings] in the [Device/PLC] window, select the external device and click [Settings] .

Individual Device Settings

PLC1

Series

Please reconfirm all of address settings that you are using if you have changed the series

■ External Device Settings

Use ladder software KV STUDIO Ver. 8 or later to define the External Device communication settings. Refer to your External Device manual for details.

- (1) Start up the ladder software.
- (2) From the [File] menu, select [New project] to display the [New project] dialog box.
- (3) In the [Project name] field enter the project name, in the [PLC model] property select the External Device, and click [OK].
- (4) In the [Confirm unit setting information] dialog box click [Yes], and the [Unit Editor] window will display.
- (5) On the [Select unit (1)] tab, from the [Extension Adapter Selection] area select "KV-NC20L".
- (6) Configure the [Extension Adapter (Port2)] as follows.

Setup Items		Setup Description
Port 2	Operation Mode	KV BUILDER/KV STUDIO mode
	Interface	RS-422A/485 (2wire)
	Baud Rate	Auto (Fixed)
	Data Bit Length	8 bits (Fixed)
	Start Bit	1 bits (Fixed)
	Stop Bit	1 bits (Fixed)
	Parity	Even (Fixed)
	Check Sum	none (Fixed)
	RS/CS Flow Control	Disabled
Base	Node No.	0
Detail Settings	Transfer timeout time (secs)	3 (Fixed)

- (7) From the [Convert] menu, select [Auto-assign relay/DM].
- (8) From the [File] menu, select [Close] and display the [Unit Editor] dialog box.
- (9) Click [Yes].
- (10) From the [Monitor/Simulator] menu, select [Transfer to PLC] to display the [Transfer Program] dialog box.
- (11) Select the [Unit setting info] and [Program] check boxes, and then click [Execute]. The settings are transferred.

This completes the setting of the External Device.

3.32 Setting Example 32

■ GP-Pro EX Settings

To display the setup screen, from the [Project] menu, point to [System Settings] and select [Device/PLC].

Device/PLC 1

Summary [Change Device/PLC](#)

Manufacturer Series Port

Text Data Mode [Change](#)

Communication Settings

SIO Type RS232C RS422/485(2wire) RS422/485(4wire)

Speed

Data Length 7 8

Parity NONE EVEN ODD

Stop Bit 1 2

Flow Control NONE ER(DTR/CTS) XON/XOFF

Timeout (sec)

Retry

Wait To Send (ms)

RI / VCC RI VCC
In the case of RS232C, you can select the 9th pin to RI (Input) or VCC (5V Power Supply). If you use the Digital's RS232C Isolation Unit, please select it to VCC.

Device-Specific Settings

Allowable Number of Devices/PLCs

No.	Device Name	Settings
<input type="button" value="x"/> 1	<input type="text" value="PLC1"/>	<input type="text" value="Series=KV-8000"/>

◆ Device Setting

To display the [Individual Device Settings] dialog box, from [Device-Specific Settings] in the [Device/PLC] window, select the external device and click [Settings] .

Individual Device Settings

PLC1

Series

Please reconfirm all of address settings that you are using if you have changed the series

■ External Device Settings

Use ladder software KV STUDIO Ver. 10 or later to define the External Device communication settings. Refer to your External Device manual for details.

- (1) Start up the ladder software.
- (2) From the [File] menu, select [New project] to display the [New project] dialog box.
- (3) In the [Project name] field enter the project name, in the [PLC model] property select the External Device, and click [OK].
- (4) In the [Confirm unit setting information] dialog box click [Yes], and the [Unit Editor] window will display.
- (5) On the [Select unit (1)] tab, from the displayed list of units select "KV-L20V", then drag & drop to the unit placement area.
- (6) In the unit placement area click "KV-L20V" and then select the [Setup unit (2)] tab.
- (7) Configure the setup items as follows.

Setup Items		Setup Description
Port 1	Operation Mode	KV BUILDER/KV STUDIO mode
	Interface	RS-232C (Fixed)
	Baud Rate	Auto (Fixed)
	Data Bit Length	8 bits (Fixed)
	Start Bit	1 bits (Fixed)
	Stop Bit	1 bits (Fixed)
	Parity	Even (Fixed)
	Check Sum	none (Fixed)
	RS/CS Flow Control	Disabled
Base	Node No.	0
Detail Settings	Transfer timeout time (secs)	3 (Fixed)

- (8) From the [Convert] menu, select [Auto-assign relay/DM].
- (9) From the [File] menu, select [Close] and display the [Unit Editor] dialog box.
- (10) Click [Yes].
- (11) From the [Monitor/Simulator] menu, select [Transfer to PLC] to display the [Transfer Program] dialog box.
- (12) Select the [Unit setting info] and [Program] check boxes, and then click [Execute]. The settings are transferred.

This completes the setting of the External Device.

3.33 Setting Example 33

■ GP-Pro EX Settings

To display the setup screen, from the [Project] menu, point to [System Settings] and select [Device/PLC].

Device/PLC 1

Summary [Change Device/PLC](#)

Manufacturer Series Port

Text Data Mode [Change](#)

Communication Settings

SIO Type RS232C RS422/485(2wire) RS422/485(4wire)

Speed

Data Length 7 8

Parity NONE EVEN ODD

Stop Bit 1 2

Flow Control NONE ER(DTR/CTS) XON/XOFF

Timeout (sec)

Retry

Wait To Send (ms)

RI / VCC RI VCC
In the case of RS232C, you can select the 9th pin to RI (Input) or VCC (5V Power Supply). If you use the Digital's RS232C Isolation Unit, please select it to VCC.

Device-Specific Settings

Allowable Number of Devices/PLCs

No.	Device Name	Settings
<input type="button" value="1"/>	<input type="text" value="PLC1"/>	<input type="text" value="Series=KV-8000"/>

◆ Device Setting

To display the [Individual Device Settings] dialog box, from [Device-Specific Settings] in the [Device/PLC] window, select the external device and click [Settings] .

Individual Device Settings

PLC1

Series

Please reconfirm all of address settings that you are using if you have changed the series

■ External Device Settings

Use ladder software KV STUDIO Ver. 10 or later to define the External Device communication settings. Refer to your External Device manual for details.

- (1) Start up the ladder software.
- (2) From the [File] menu, select [New project] to display the [New project] dialog box.
- (3) In the [Project name] field enter the project name, in the [PLC model] property select the External Device, and click [OK].
- (4) In the [Confirm unit setting information] dialog box click [Yes], and the [Unit Editor] window will display.
- (5) On the [Select unit (1)] tab, from the displayed list of units select "KV-L20V", then drag & drop to the unit placement area.
- (6) In the unit placement area click "KV-L20V" and then select the [Setup unit (2)] tab.
- (7) Configure the setup items as follows.

Setup Items		Setup Description
Port 2	Operation Mode	KV BUILDER/KV STUDIO mode
	Interface	RS-232C
	Baud Rate	Auto (Fixed)
	Data Bit Length	8 bits (Fixed)
	Start Bit	1 bits (Fixed)
	Stop Bit	1 bits (Fixed)
	Parity	Even (Fixed)
	Check Sum	none (Fixed)
Base	Node No.	0
Detail Settings	Transfer timeout time (secs)	3 (Fixed)

- (8) From the [Convert] menu, select [Auto-assign relay/DM].
- (9) From the [File] menu, select [Close] and display the [Unit Editor] dialog box.
- (10) Click [Yes].
- (11) From the [Monitor/Simulator] menu, select [Transfer to PLC] to display the [Transfer Program] dialog box.
- (12) Select the [Unit setting info] and [Program] check boxes, and then click [Execute]. The settings are transferred.

This completes the setting of the External Device.

3.34 Setting Example 34

■ GP-Pro EX Settings

To display the setup screen, from the [Project] menu, point to [System Settings] and select [Device/PLC].

Device/PLC 1

Summary [Change Device/PLC](#)

Manufacturer Series Port

Text Data Mode [Change](#)

Communication Settings

SIO Type RS232C RS422/485(2wire) RS422/485(4wire)

Speed

Data Length 7 8

Parity NONE EVEN ODD

Stop Bit 1 2

Flow Control NONE ER(DTR/CTS) XON/XOFF

Timeout (sec)

Retry

Wait To Send (ms)

RI / VCC RI VCC
In the case of RS232C, you can select the 9th pin to RI (Input) or VCC (5V Power Supply). If you use the Digital's RS232C Isolation Unit, please select it to VCC.

Device-Specific Settings

Allowable Number of Devices/PLCs

No.	Device Name	Settings
<input type="button" value="1"/>	<input type="text" value="PLC1"/>	<input type="text" value="Series=KV-8000"/>

◆ Device Setting

To display the [Individual Device Settings] dialog box, from [Device-Specific Settings] in the [Device/PLC] window, select the external device and click [Settings] .

Individual Device Settings

PLC1

Series

Please reconfirm all of address settings that you are using if you have changed the series

■ External Device Settings

Use ladder software KV STUDIO Ver. 10 or later to define the External Device communication settings. Refer to your External Device manual for details.

- (1) Start up the ladder software.
- (2) From the [File] menu, select [New project] to display the [New project] dialog box.
- (3) In the [Project name] field enter the project name, in the [PLC model] property select the External Device, and click [OK].
- (4) In the [Confirm unit setting information] dialog box click [Yes], and the [Unit Editor] window will display.
- (5) On the [Select unit (1)] tab, from the displayed list of units select "KV-L20V", then drag & drop to the unit placement area.
- (6) In the unit placement area click "KV-L20V" and then select the [Setup unit (2)] tab.
- (7) Configure the setup items as follows.

Setup Items		Setup Description
Port 2	Operation Mode	KV BUILDER/KV STUDIO mode
	Interface	RS-422A/485 (4wire)
	Baud Rate	Auto (Fixed)
	Data Bit Length	8 bits (Fixed)
	Start Bit	1 bits (Fixed)
	Stop Bit	1 bits (Fixed)
	Parity	Even (Fixed)
	Check Sum	none (Fixed)
Base	Node No.	0
Detail Settings	Transfer timeout time (secs)	3 (Fixed)

- (8) From the [Convert] menu, select [Auto-assign relay/DM].
- (9) From the [File] menu, select [Close] and display the [Unit Editor] dialog box.
- (10) Click [Yes].
- (11) From the [Monitor/Simulator] menu, select [Transfer to PLC] to display the [Transfer Program] dialog box.
- (12) Select the [Unit setting info] and [Program] check boxes, and then click [Execute]. The settings are transferred.

This completes the setting of the External Device.

3.35 Setting Example 35

■ GP-Pro EX Settings

To display the setup screen, from the [Project] menu, point to [System Settings] and select [Device/PLC].

Device/PLC 1

Summary [Change Device/PLC](#)

Manufacturer Series Port

Text Data Mode [Change](#)

Communication Settings

SIO Type RS232C RS422/485(2wire) RS422/485(4wire)

Speed

Data Length 7 8

Parity NONE EVEN ODD

Stop Bit 1 2

Flow Control NONE ER(DTR/CTS) XON/XOFF

Timeout (sec)

Retry

Wait To Send (ms)

RI / VCC RI VCC
In the case of RS232C, you can select the 9th pin to RI (Input) or VCC (5V Power Supply). If you use the Digital's RS232C Isolation Unit, please select it to VCC.

Device-Specific Settings

Allowable Number of Devices/PLCs

No.	Device Name	Settings
<input type="button" value="1"/>	<input type="text" value="PLC1"/>	<input type="text" value="Series=KV-8000"/>

◆ Device Setting

To display the [Individual Device Settings] dialog box, from [Device-Specific Settings] in the [Device/PLC] window, select the external device and click [Settings] .

Individual Device Settings

PLC1

Series

Please reconfirm all of address settings that you are using if you have changed the series

■ External Device Settings

Use ladder software KV STUDIO Ver. 10 or later to define the External Device communication settings. Refer to your External Device manual for details.

- (1) Start up the ladder software.
- (2) From the [File] menu, select [New project] to display the [New project] dialog box.
- (3) In the [Project name] field enter the project name, in the [PLC model] property select the External Device, and click [OK].
- (4) In the [Confirm unit setting information] dialog box click [Yes], and the [Unit Editor] window will display.
- (5) On the [Select unit (1)] tab, from the displayed list of units select "KV-L20V", then drag & drop to the unit placement area.
- (6) In the unit placement area click "KV-L20V" and then select the [Setup unit (2)] tab.
- (7) Configure the setup items as follows.

Setup Items		Setup Description
Port 2	Operation Mode	KV BUILDER/KV STUDIO mode
	Interface	RS-485 (2wire)
	Baud Rate	Auto (Fixed)
	Data Bit Length	8 bits (Fixed)
	Start Bit	1 bits (Fixed)
	Stop Bit	1 bits (Fixed)
	Parity	Even (Fixed)
	Check Sum	none (Fixed)
Base	Node No.	0
Detail Settings	Transfer timeout time (secs)	3 (Fixed)

- (8) From the [Convert] menu, select [Auto-assign relay/DM].
- (9) From the [File] menu, select [Close] and display the [Unit Editor] dialog box.
- (10) Click [Yes].
- (11) From the [Monitor/Simulator] menu, select [Transfer to PLC] to display the [Transfer Program] dialog box.
- (12) Select the [Unit setting info] and [Program] check boxes, and then click [Execute]. The settings are transferred.

This completes the setting of the External Device.

4 Setup Items

Set up the Display's communication settings in GP-Pro EX or in the Display's offline mode.

The setting of each parameter must match that of the External Device.

 "3 Communication Settings" (page 12)

4.1 Setup Items in GP-Pro EX

■ Communication Settings

To display the setup screen, from the [Project] menu, point to [System Settings] and select [Device/PLC].

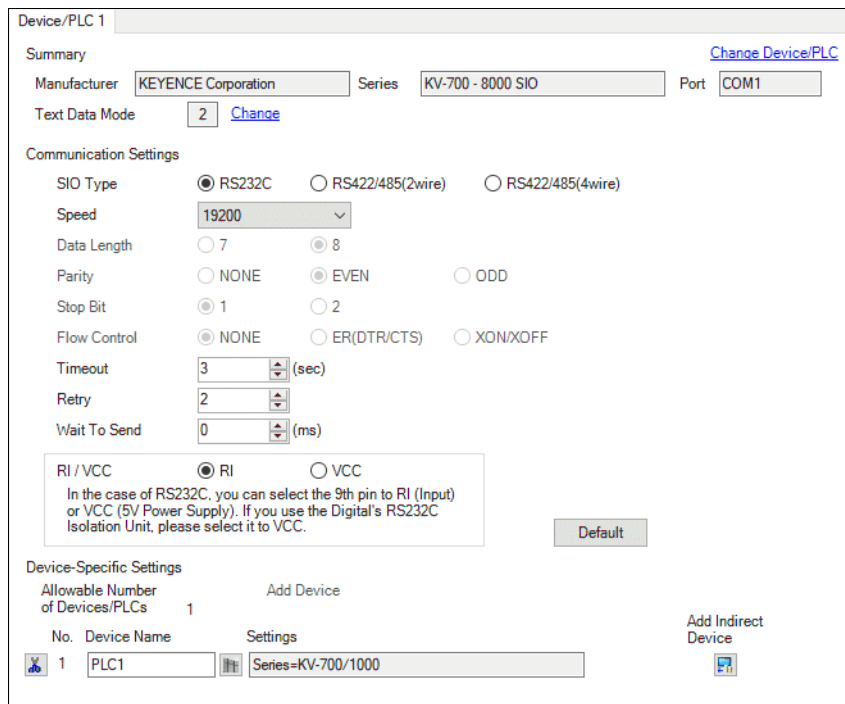

Device/PLC 1 [Change Device/PLC](#)

Summary
 Manufacturer Series Port
 Text Data Mode [Change](#)

Communication Settings
 SIO Type RS232C RS422/485(2wire) RS422/485(4wire)
 Speed
 Data Length 7 8
 Parity NONE EVEN ODD
 Stop Bit 1 2
 Flow Control NONE ER(DTR/CTS) XON/XOFF
 Timeout (sec)
 Retry
 Wait To Send (ms)

RI / VCC RI VCC
 In the case of RS232C, you can select the 9th pin to RI (Input) or VCC (5V Power Supply). If you use the Digital's RS232C Isolation Unit, please select it to VCC.

Default

Device-Specific Settings
 Allowable Number of Devices/PLCs [Add Device](#)
 No. Device Name Settings [Add Indirect Device](#)

No.	Device Name	Settings
1	PLC1	Series=KV-700/1000

Setup Items	Setup Description
SIO Type	Select the SIO type for communicating with the External Device.
Speed	Select the communication speed between the External Device and the Display.
Data Length	Select a data length.
Parity	Select how to check parity.
Stop Bit	Select a stop bit length.
Flow Control	Select the communication control method to prevent overflow of transmission and reception data.
Timeout	Enter the time (s) for which the Display waits for the response from the External Device, from "1 to 127".
Retry	In case of no response from the External Device, enter how many times the Display retransmits the command, from "0 to 255".
Wait To Send	Enter the standby time (ms) from when the Display receives packets until it transmits the next command, from "0 to 255".

Setup Items	Setup Description
RI/VCC	You can switch between RI/VCC for the 9th pin when you select RS-232C for SIO type. To connect to the IPC, switch between RI/5V using the IPC selector switch. Refer to your IPC manual for details.

NOTE

- Refer to the GP-Pro EX Reference Manual for Indirect Device.

Cf. GP-Pro EX Reference Manual "Changing the Device/PLC at Runtime (Indirect Device)"

■ Device Setting

To display the [Individual Device Settings] dialog box, from [Device-Specific Settings] in the [Device/PLC] window, select the external device and click [Settings] .

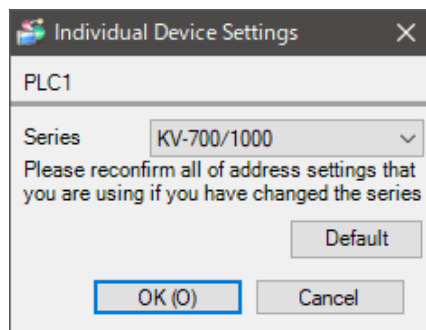

Setup Items	Setup Description
Series	Select the series of the External Device.

4.2 Setup Items in Offline Mode

NOTE

- Refer to the Maintenance/Troubleshooting guide for information on how to enter offline mode or about the operation.

Cf. Maintenance/Troubleshooting Guide "Offline Mode"

- The number of the setup items to be displayed for 1 page in the offline mode depends on the Display in use. Please refer to the Reference manual for details.

■ Communication Settings

To display the setting screen, touch [Device/PLC Settings] from [Peripheral Settings] in offline mode. Touch the External Device you want to set from the displayed list.

Comm.	Device	Option		
KV-700 - 8000 SIO		[COM1]	Page 1/1	
SIO Type		RS232C	▼	
Speed		19200	▼	
Data Length		8		
Parity		EVEN		
Stop Bit		1		
Flow Control		NONE		
Timeout(s)		3	▼	▲
Retry		2	▼	▲
Wait to Send(ms)		0	▼	▲
Exit		Back		2022/01/26 18:26:07

Setup Items	Setup Description
SIO Type	Select the SIO type for communicating with the External Device. IMPORTANT In the communication settings, set [SIO Type] correctly according to the serial interface specifications of the Display. If you select an SIO type that the serial interface does not support, proper operation cannot be guaranteed. Refer to your Display manual for details on the serial interface specifications.
Speed	Select the communication speed between the External Device and the Display.
Data Length	Data length is displayed.

Setup Items	Setup Description
Parity	The parity check method is displayed.
Stop Bit	Stop bit length is displayed.
Flow Control	The communication control method to prevent overflow of transmission and reception data.
Timeout	Enter the time (s) for which the Display waits for the response from the External Device, from "1 to 127".
Retry	In case of no response from the External Device, enter how many times the Display retransmits the command, from "0 to 255".
Wait To Send	Enter the standby time (ms) from when the Display receives packets until it transmits the next command, from "0 to 255".

■ Device Setting

To display the setting screen, touch [Device/PLC Settings] from [Peripheral Settings]. Touch the External Device you want to set from the list that appears, and touch [Device].

Comm.	Device	Option		
KV-700 - 8000 SIO		[COM1]	Page 1/1	
Device/PLC Name		PLC1		
Series		KV-700/1000		
Exit		Back		2022/01/26 18:26:31

Setup Items	Setup Description
Device/PLC Name	Select the External Device to set. Device/PLC Name is the title of the External Device set with GP-Pro EX. (Initial value [PLC1])
Series	Displays the series of the External Device.

■ Option

To display the setting screen, touch [Device/PLC Settings] from [Peripheral Settings]. Touch the External Device you want to set from the list that appears, and touch [Option].

Comm.	Device	Option		
KV-700 - 8000 SIO			[COM1]	Page 1/1
RI / VCC <input checked="" type="radio"/> RI <input type="radio"/> VCC In the case of RS232C, you can select the 9th pin to RI(Input) or VCC(5V Power Supply). If you use the Digital's RS232C Isolation Unit, please select it to VCC.				
	Exit		Back	2012/02/17 10:18:39

Setup Items	Setup Description
RI/VCC	You can switch between RI/VCC for the 9th pin when you select RS-232C for SIO type. To connect to the IPC, you need to switch between RI/5V using the IPC selector switch. Refer to your IPC manual for details.

NOTE

- GP-4100 series, GP-4*01TM, GP-Rear Module, LT-4*01TM and LT-Rear Module do not have the [Option] setting in the offline mode.

5 Cable Diagrams

The cable diagrams shown below may be different from the cable diagrams recommended by KEYENCE Corporation. Please be assured there is no operational problem in applying the cable diagrams shown in this manual.

- The FG pin on the External Device must be D-class grounded. Refer to your External Device manual for details.
- The SG and FG are connected inside the Display. If you connect the External Device to the SG, do not form any short-circuit loop in the system design.
- If the communication is not stable because of noise or other factors, connect an isolation unit.

Cable Diagram 1

Display (Connection Port)	Cable		Remarks
GP3000 (COM1) GP4000 ^{*1} (COM1) SP5000 ^{*2} (COM1/2) SP-5B00 (COM1) ST3000 (COM1) ST6000 (COM1) STM6000 (COM1) LT3000 (COM1) IPC ^{*3} PC/AT	1A	D-sub 9Pin by KEYENCE Corporation OP-26486 + Modular cable by KEYENCE Corporation OP-26487 (2.5m)	
GP-4105 (COM1) GP-4115T (COM1) GP-4115T3 (COM1)	1B	User-created cable + D-sub 9Pin by KEYENCE Corporation OP-26486 + Modular cable by KEYENCE Corporation OP-26487 (2.5m)	

*1 All GP4000 models except GP-4100 Series and GP-4203T

*2 Except SP-5B00

*3 Available only with COM ports that support RS-232C.

 ■ IPC COM Port (page 8)

1A)

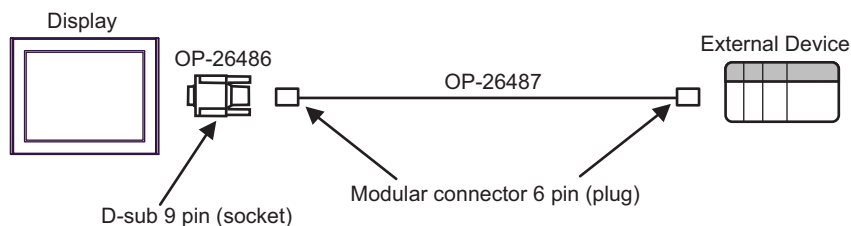

1B)

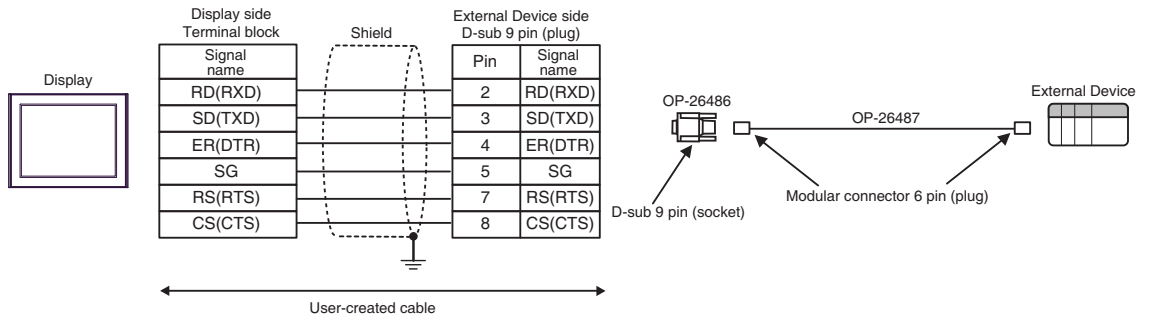

Cable Diagram 2

Display (Connection Port)	Cable		Remarks
GP3000 (COM1) GP4000* ¹ (COM1) SP5000* ² (COM1/2) SP-5B00 (COM1) ST3000 (COM1) ST6000 (COM1) STM6000 (COM1) LT3000 (COM1) IPC* ³ PC/AT	2A	User-created cable	The cable length must be 15m or less.
GP-4105 (COM1) GP-4115T (COM1) GP-4115T3 (COM1)	2B	User-created cable	The cable length must be 15m or less.
LT-4*01TM (COM1) LT-Rear Module (COM1)	2C	RJ45 RS-232C Cable (5m) by Pro-face PFXZLMCBRJ21	The cable length must be 5m or less.

*1 All GP4000 models except GP-4100 Series and GP-4203T

*2 Except SP-5B00

*3 Available only with COM ports that support RS-232C.

 ■ IPC COM Port (page 8)

2A)

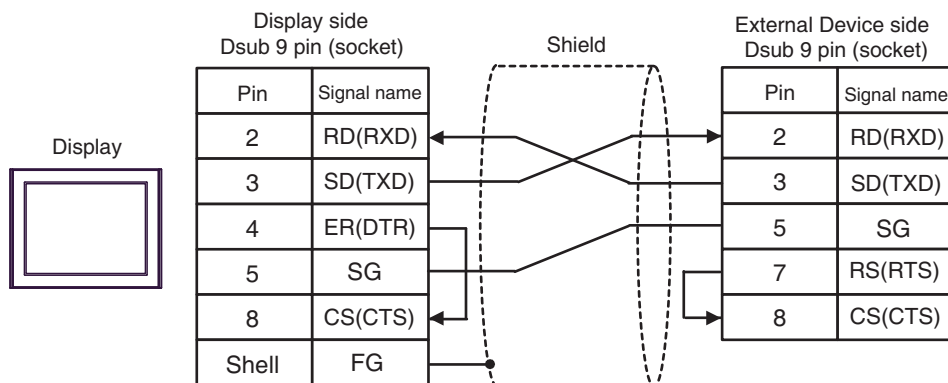

2B)

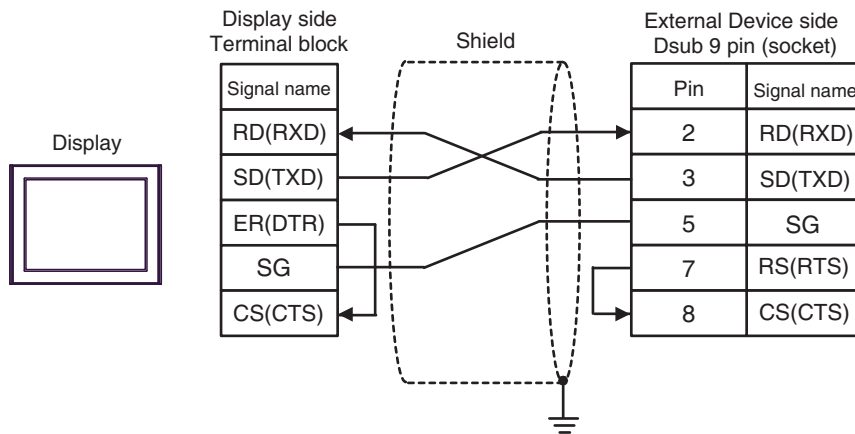

2C)

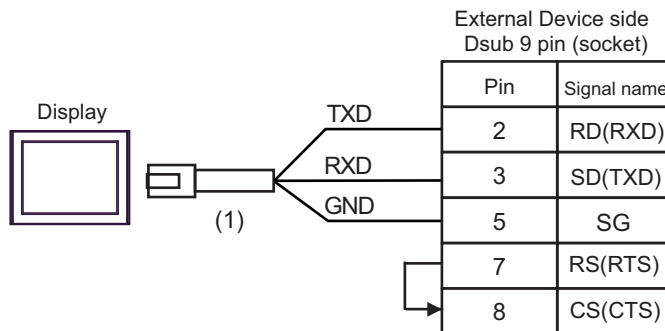

Legend	Name	Note
(1)	RJ45 RS-232C Cable (5m) by Pro-face PFXZLMCBJR21	

Cable Diagram 3

Display (Connection Port)	Cable		Remarks
GP3000 (COM1) GP4000* ¹ (COM1) SP5000* ² (COM1/2) SP-5B00 (COM1) ST3000 (COM1) ST6000 (COM1) STM6000 (COM1) LT3000 (COM1) IPC* ³ PC/AT	3A	User-created cable	The cable length must be 15m or less.
GP-4105 (COM1) GP-4115T (COM1) GP-4115T3 (COM1)	3B	User-created cable	The cable length must be 15m or less.
LT-4*01TM (COM1) LT-Rear Module (COM1)	3C	RJ45 RS-232C Cable (5m) by Pro-face PFXZLMCBJR21	The cable length must be 5m or less.

*1 All GP4000 models except GP-4100 Series and GP-4203T

*2 Except SP-5B00

*3 Available only with COM ports that support RS-232C.

 ■ IPC COM Port (page 8)

NOTE

- Set the PORT2 toggle switch on the External Device to "232C".

3A)

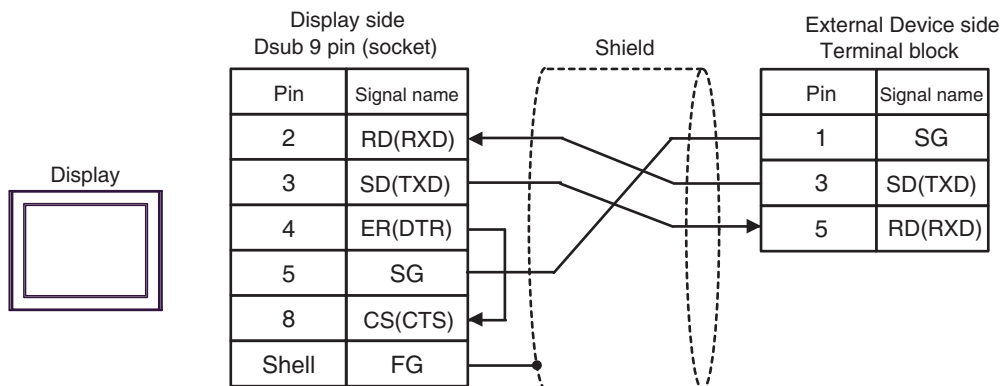

3B)

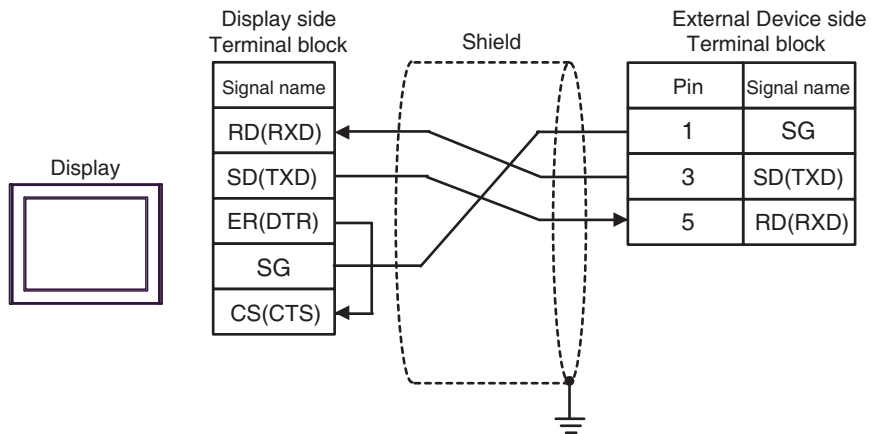

3C)

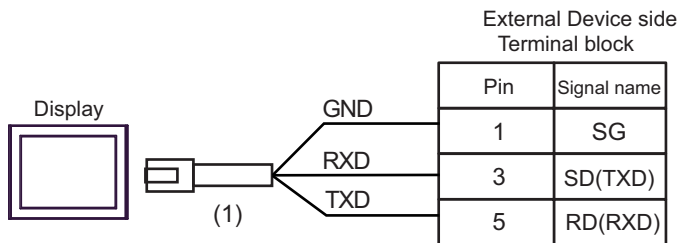

Legend	Name	Note
(1)	RJ45 RS-232C Cable (5m) by Pro-face PFXZLMCBJR21	

Cable Diagram 4

Display (Connection Port)	Cable		Remarks
GP3000* ¹ (COM1) AGP-3302B (COM2) GP-4*01TM (COM1) GP-Rear Module (COM1) ST3000* ² (COM2) LT3000 (COM1) IPC* ³	4A	COM port conversion adapter by Pro-face CA3-ADPCOM-01 + Connector terminal block conversion adapter by Pro-face CA3-ADPTRM-01 + User-created cable	The cable length must be 500m or less.
	4B	User-created cable	
GP3000* ¹ (COM2)	4C	Online adapter by Pro-face CA4-ADPONL-01 + Connector terminal block conversion adapter by Pro-face CA3-ADPTRM-01 + User-created cable	The cable length must be 500m or less.
	4D	Online adapter by Pro-face CA4-ADPONL-01 + User-created cable	
GP-4106 (COM1) GP-4116T (COM1)	4E	User-created cable	The cable length must be 500m or less.
GP4000* ⁴ (COM2) GP-4201T (COM1) SP5000* ⁵ (COM1/2) SP-5B00 (COM2) ST6000* ⁶ (COM2) ST-6200 (COM1) STM6000 (COM1)	4F	RS-422 Terminal Block Conversion Adapter by Pro-face PFXZCBADTM1* ⁷ + User-created cable	The cable length must be 500m or less.
	4B	User-created cable	
PE-4000B* ⁸ PS5000* ⁸ PS6000* ⁸	4G	User-created cable	The cable length must be 500m or less.

*1 All GP3000 models except AGP-3302B

*2 Except AST-3211A and AST-3302B

*3 Available only with COM ports that support RS-422/485 (4wire). (Except PE-4000B, PS5000, and PS6000)
■ IPC COM Port (page 8)

*4 All GP4000 models except GP-4100 Series, GP-4*01TM, GP-Rear Module, GP-4201T and GP-4*03T

*5 Except SP-5B00

*6 Except ST-6200

*7 When using a Terminal Block Conversion Adapter (CA3-ADPTRM-01) instead of the RS-422 Terminal Block Conversion Adapter, refer to Cable Diagram 4A.

*8 Available only with COM ports that support RS-422/485 (4wire).
■ IPC COM Port (page 8)

IMPORTANT

- Terminal number to be used for communication varies depending on the External Device. Terminal numbers corresponding to each series are shown below.

Pin	KV-L20V KV-L21V	KV-N11L KV-NC20L
SDB(+)	5	2
SDA(-)	3	1
RDB(+)	4	3
RDA(-)	2	4
SG	1	5

NOTE

- Set the PORT2 toggle switch on the External Device to "422A 485(4)". Also, turn ON the switch of the terminator.
- Pay attention that pole A and pole B are reversely named for the Display and the External Device.

4A)

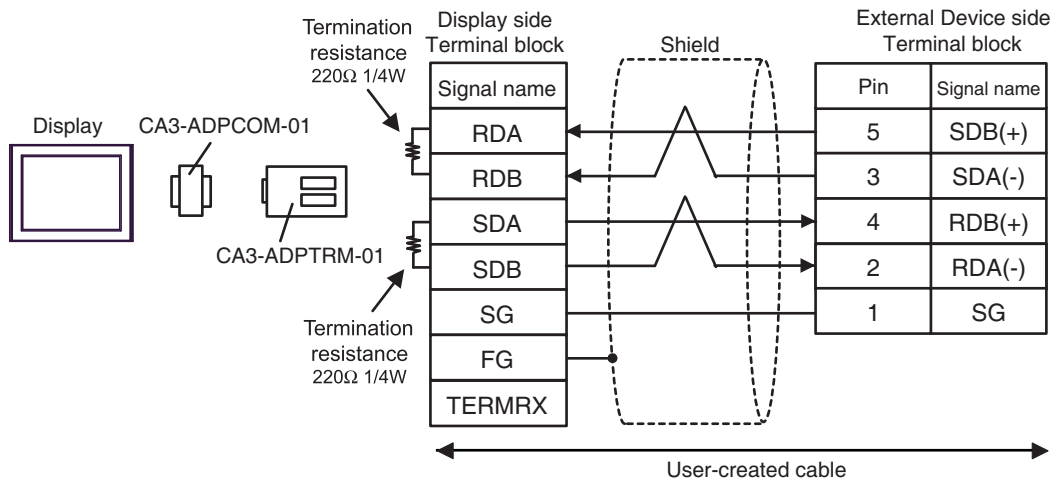

4B)

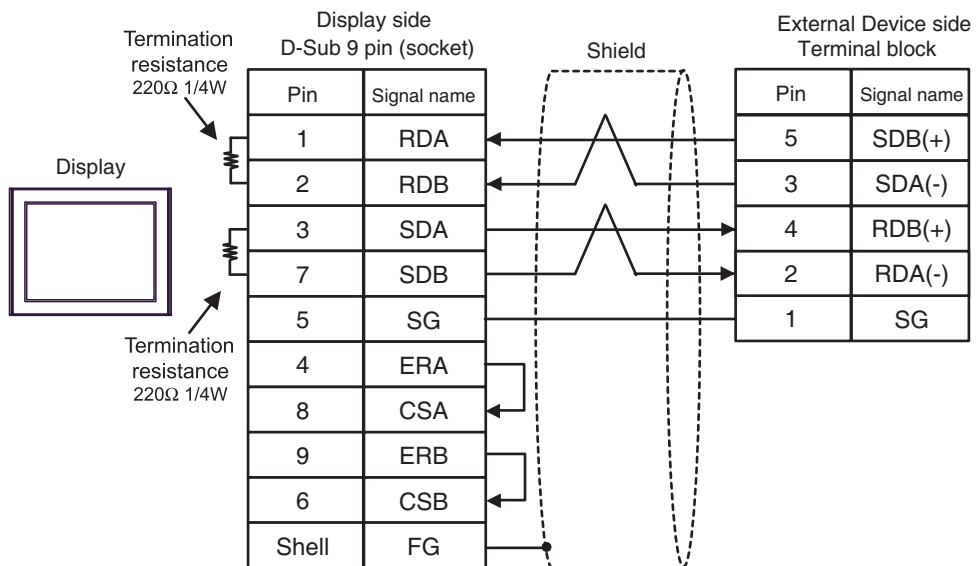

4C)

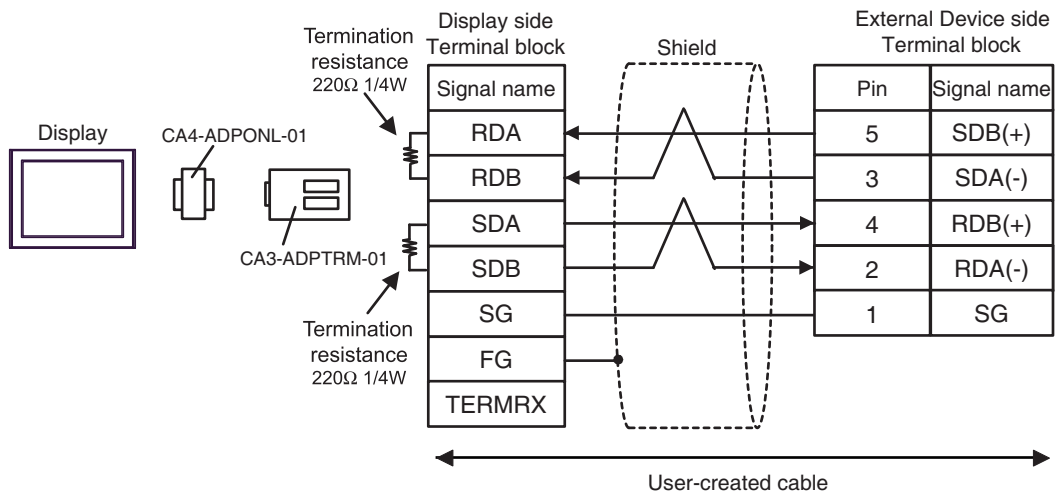

4D)

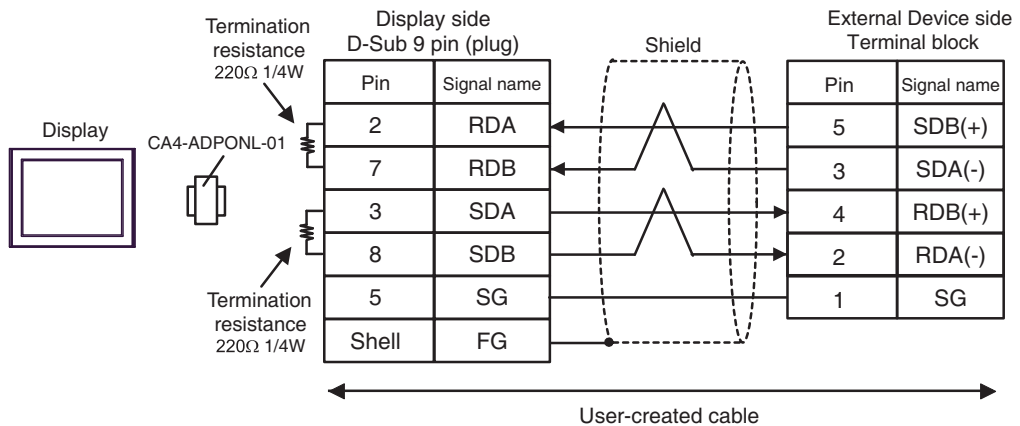

4E)

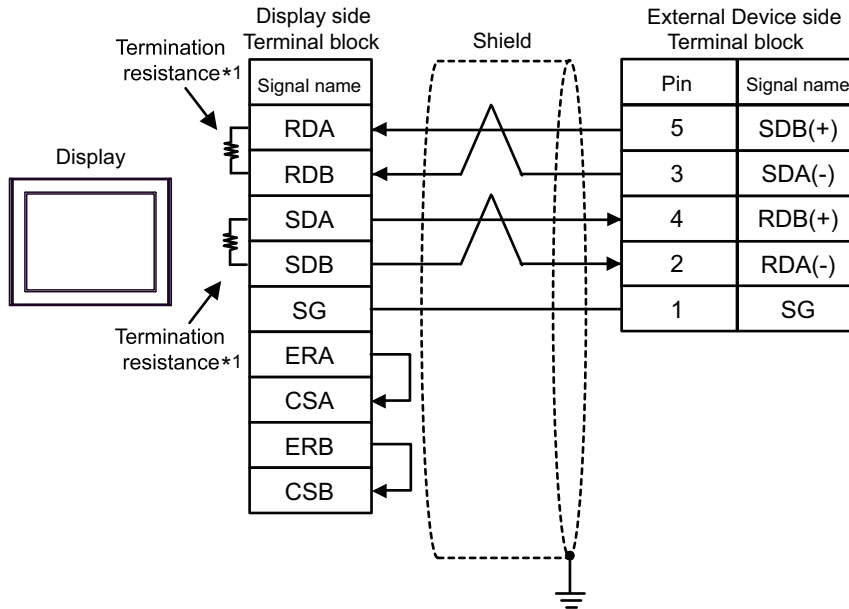

- *1 The resistance in the Display is used as the termination resistance. Set the value of the DIP Switch on the rear of the Display as shown in the table below.

DIP Switch No.	Set Value
1	OFF
2	ON
3	OFF
4	ON

4F)

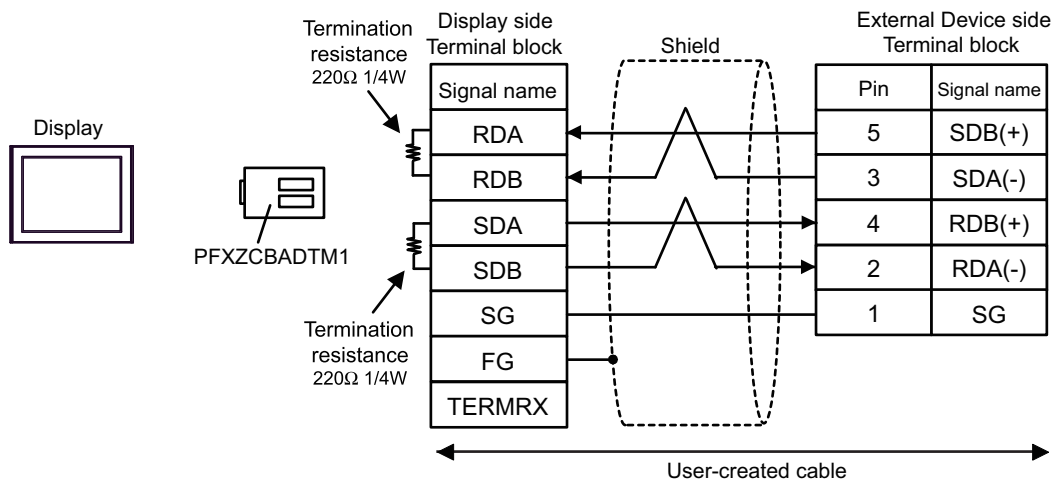

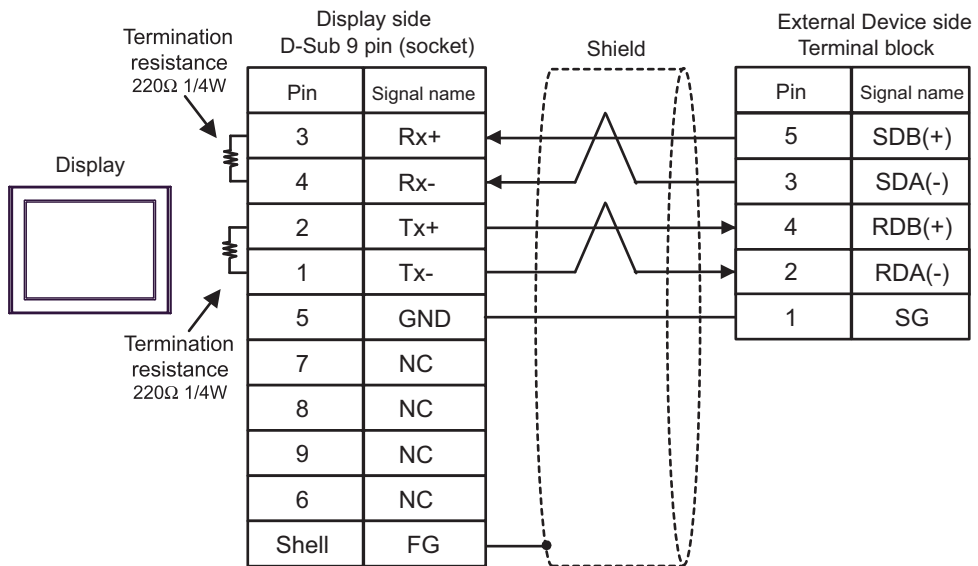

4G)



Cable Diagram 5

Display (Connection Port)	Cable		Notes
GP3000* ¹ (COM1) AGP-3302B (COM2) GP-4*01TM (COM1) GP-Rear Module (COM1) ST3000* ² (COM2) LT3000 (COM1)	5A	COM port conversion adapter by Pro-face CA3-ADPCOM-01 + Terminal block conversion adapter by Pro-face CA3-ADPTRM-01 + User-created cable	Cable length: 1000m or less
	5B	User-created cable	
GP3000* ³ (COM2)	5C	Online adapter by Pro-face CA4-ADPONL-01 + Terminal block conversion adapter by Pro-face CA3-ADPTRM-01 + User-created cable	Cable length: 1000m or less
	5D	Online adapter by Pro-face CA4-ADPONL-01 + User-created cable	
IPC* ⁴	5E	COM port conversion adapter by Pro-face CA3-ADPCOM-01 + Terminal block conversion adapter by Pro-face CA3-ADPTRM-01 + User-created cable	Cable length: 1000m or less
	5F	User-created cable	
GP-4106 (COM1) GP-4116T (COM1)	5G	User-created cable	Cable length: 1000m or less
GP-4107 (COM1) GP-4*03T* ⁵ (COM2) GP-4203T (COM1)	5H	User-created cable	Cable length: 1000m or less
GP4000* ⁶ (COM2) GP-4201T (COM1) SP5000* ⁷ (COM1/2) SP-5B00 (COM2) ST6000* ⁸ (COM2) ST-6200 (COM1) STM6000 (COM1)	5I	RS-422 Terminal Block Conversion Adapter by Pro-face PFXZCBADTM1* ⁹ + User-created cable	Cable length: 1000m or less
	5B	User-created cable	
LT-4*01TM (COM1) LT-Rear Module (COM1)	5J	RJ45 RS-485 Cable (5m) by Pro-face PFXZLMCBJR81	Cable length: 200m or less

Display (Connection Port)	Cable		Notes
PE-4000B*10 PS5000*10 PS6000*10	5K	User-created cable	Cable length: 1000m or less

- *1 All GP3000 models except AGP-3302B
- *2 Except AST-3211A and AST-3302B
- *3 All GP3000 models except GP-3200 series and AGP-3302B
- *4 Only the COM port which can communicate by RS-422/485 (2 wire) can be used. (Except PE-4000B, PS5000, and PS6000)
 ■ IPC COM Port (page 8)
- *5 Except GP-4203T
- *6 All GP4000 models except GP-4100 Series, GP-4*01TM, GP-Rear Module, GP-4201T and GP-4*03T
- *7 Except SP-5B00
- *8 Except ST-6200
- *9 When using a Terminal Block Conversion Adapter (CA3-ADPTRM-01) instead of the RS-422 Terminal Block Conversion Adapter, refer to Cable Diagram 5A.
- *10 Only the COM port which can communicate by RS-422/485 (2 wire) can be used.
 ■ IPC COM Port (page 8)

IMPORTANT

- Terminal number to be used for communication varies depending on the External Device. Terminal numbers corresponding to each series are shown below.

Pin	KV-L20V KV-L21V	KV-N11L KV-NC20L
SG	1	5
S/R(-)	3	1
S/R(+)	5	2

5A)

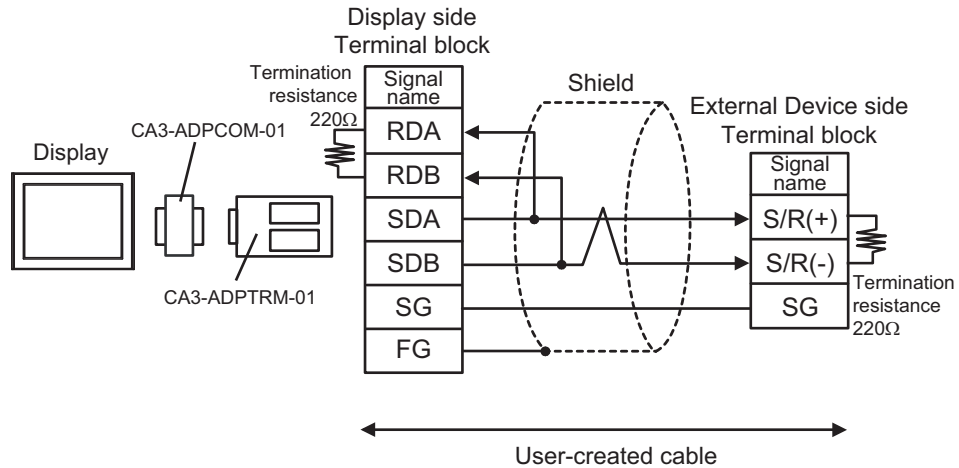

5B)

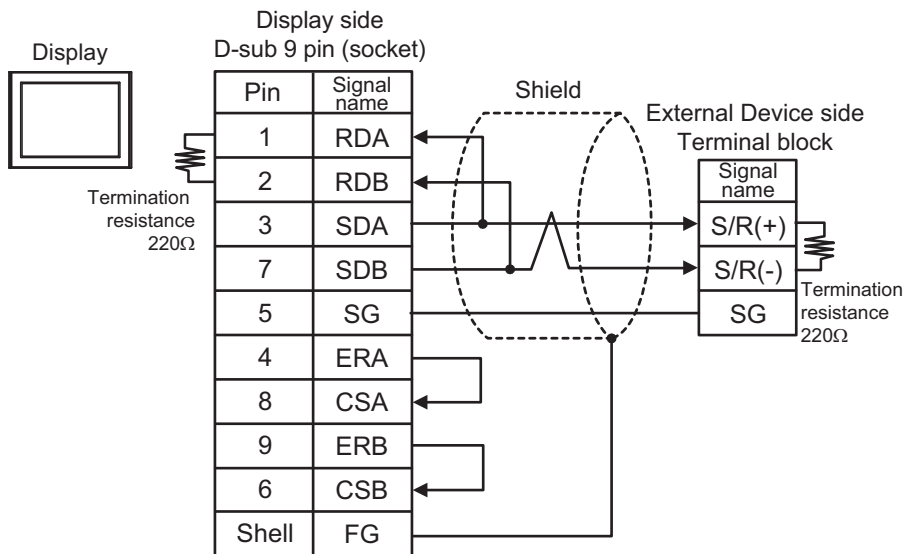

5C)

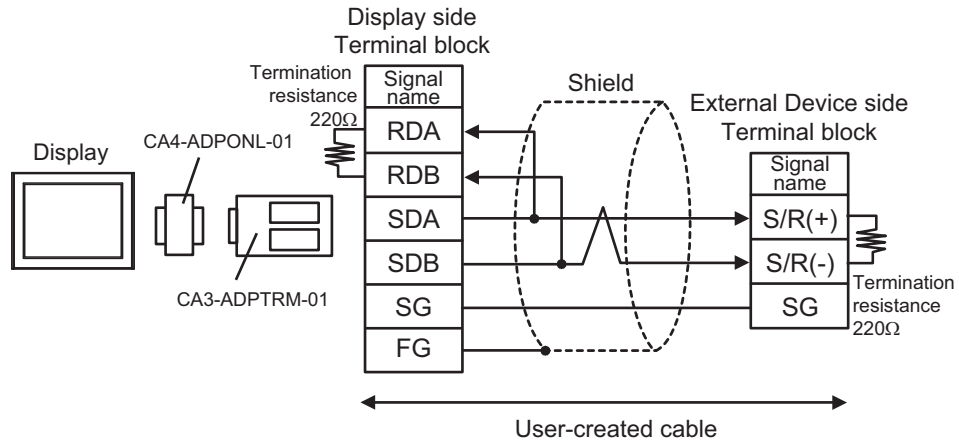

5D)

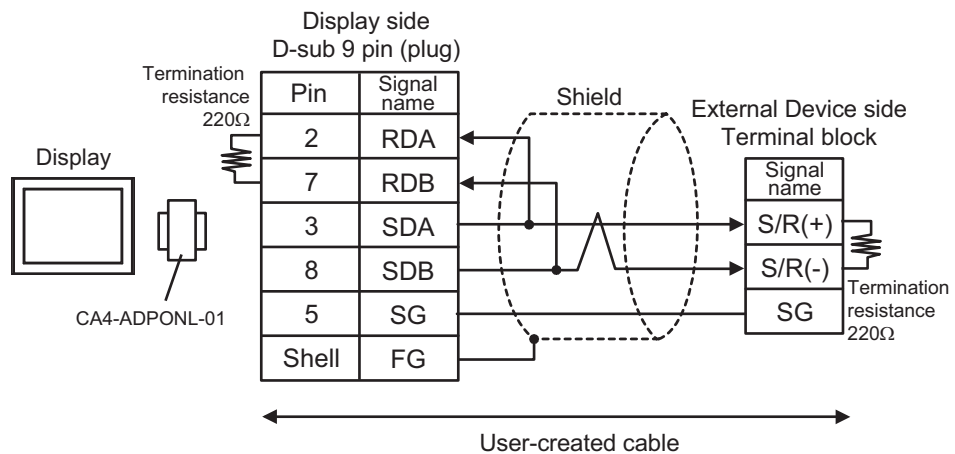

5E)

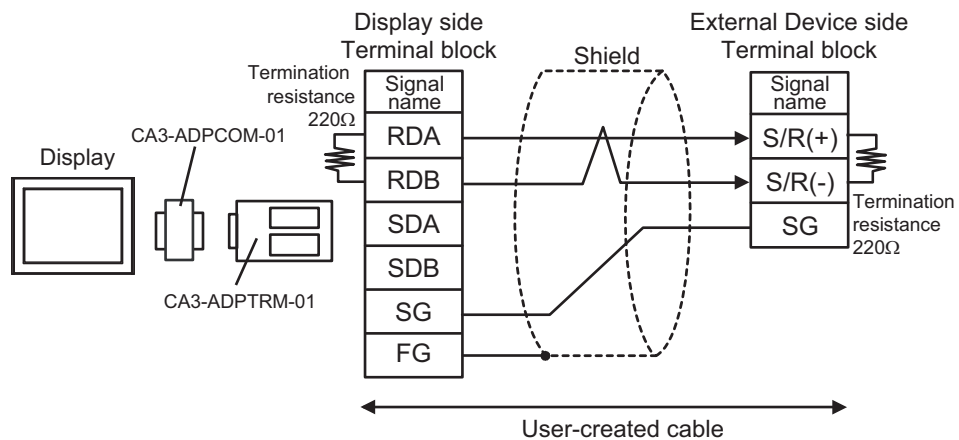

5F)

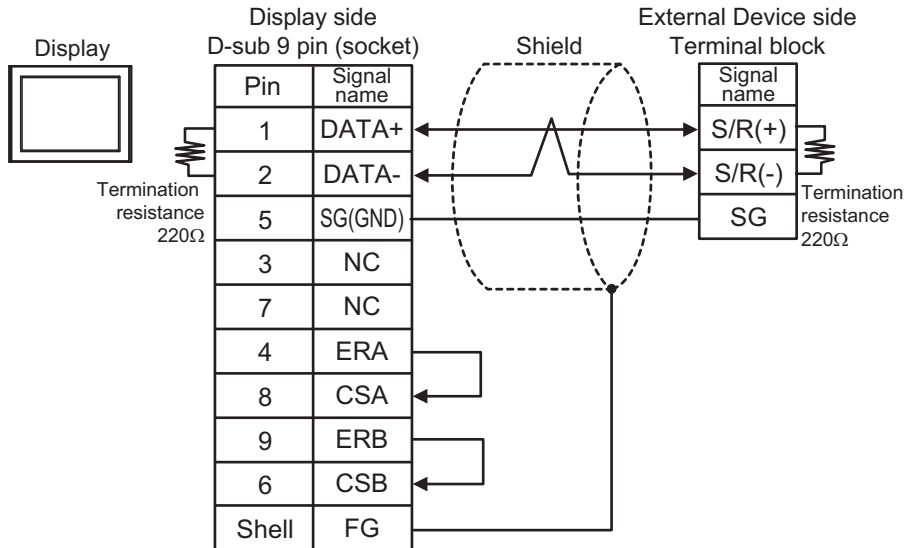

5G)

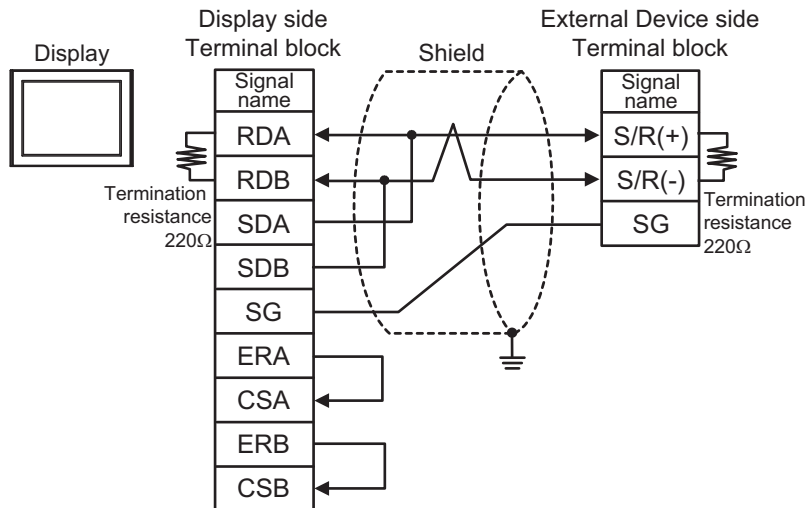

*1 The resistance in the Display is used as the termination resistance. Set the value of the DIP Switch on the rear of the Display as shown in the table below.

DIP Switch No.	Set Value
1	OFF
2	OFF
3	OFF
4	ON

5H)

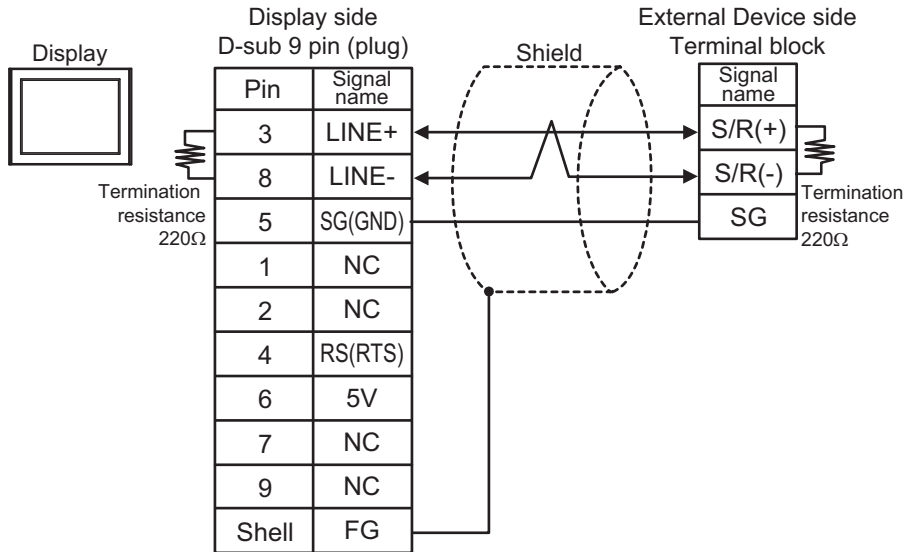
**NOTE**

- In COM on the GP-4107, the SG and FG terminals are isolated.

5I)

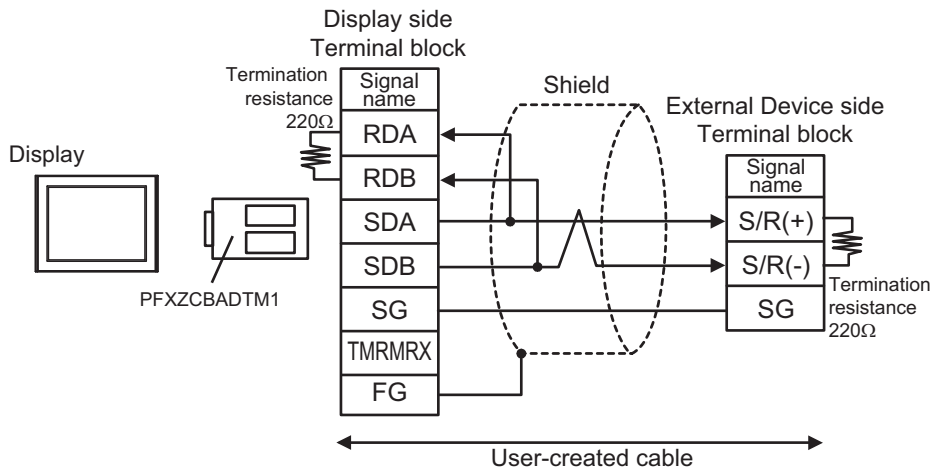

5J)

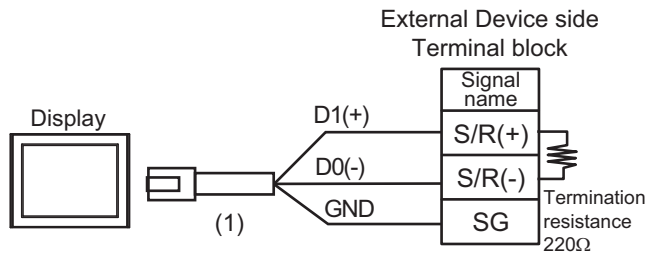

Number	Name	Notes
(1)	RJ45 RS-485 Cable (5m) by Pro-face PFXZLMCBRJ81	

5K)

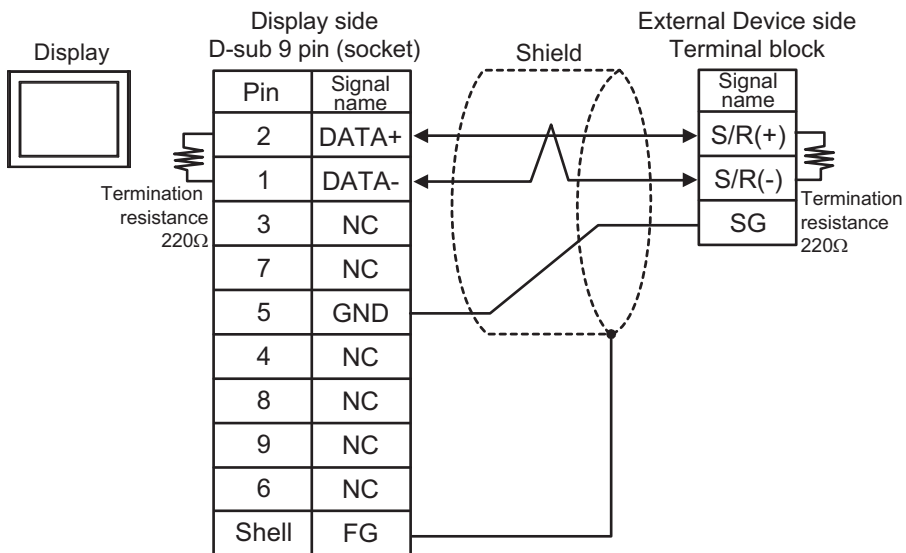

6 Supported Device

The range of supported device addresses is shown in the table below. Please note that the actual supported range for devices varies depending on the external device that is used. Please check the actual range in the external device manual.

6.1 KV-700 Series

 : This address can be specified as system data area.

Device	Bit Address	Word Address	32 bits	Remarks
Input Relay	00000 - 59915	000 - 599	L/H	
Output Relay				
Internal Auxiliary Relay				
Control Relay	CR0000 - CR3915	CR00 - CR39		
Timer (Contact)	T000 - T511	-----	-	
Counter (Contact)	C000 - C511	-----		
High-speed Counter Comparator (Contact)	CTC0 - CTC3	-----		*1
Timer (Setting Value)	-----	TS000 - TS511	L/H	*2
Counter (Setting Value)	-----	CS000 - CS511		*2
Timer (Current Value)	-----	TC000 - TC511		*2
Counter (Current Value)	-----	CC000 - CC511		*2
Data Memory	-----	DM00000 - DM39999		Bit 15
Temporary Data Memory	-----	TM000 - TM511		Bit 15
Control Memory	-----	CM0000 - CM3999		Bit 15
Digital Trimmer	-----	TRM0 - TRM7		*2
High-speed Counter (Current Value)	-----	CTH0 - CTH1		*2
High-speed Counter Comparator (Setting Value)	-----	CTC0 - CTC3		*2

*1 Write disable

*2 32-bit device

IMPORTANT

- When connecting KV-700 Series, use settings within the device address ranges above.
- If you try to access device addresses supported only by the KV-1000 Series devices, the following error messages display: "Error has been responded for device read command (Error Code(02)[(0x02)]" or "Error has been responded for device write command (Error Code(02)[(0x02)]".

NOTE

- Refer to the GP-Pro EX Reference Manual for system data area.

Cf. GP-Pro EX Reference Manual "LS Area (Direct Access Method Area)"

- Refer to the precautions on manual notation for icons in the table.

 "Manual Symbols and Terminology"

6.2 KV-1000 Series

 : This address can be specified as system data area.

Device	Bit Address	Word Address	32 bits	Remarks
Input Relay	00000 - 59915	000 - 599	L/H	*1
Output Relay				*1
Internal Auxiliary Relay				*1
Internal Auxiliary Relay	MR00000 - MR99915	MR000 - MR999		
Latch Relay	LR00000 - LR99915	LR000 - LR999		
Control Relay	CR00000 - CR3915	CR00 - CR39		
Timer (Contact)	T0000 - T3999	-----	-	
Counter (Contact)	C0000 - C3999	-----		
High-speed Counter Comparator (Contact)	CTC0 - CTC3	-----		*2
Timer (Setting Value)	-----	TS0000 - TS3999	L/H	*3
Counter (Setting Value)	-----	CS0000 - CS3999		*3
Timer (Current Value)	-----	TC0000 - TC3999		*3
Counter (Current Value)	-----	CC0000 - CC3999		*3
Data Memory	-----	DM00000 - DM65534		Bit 15
Extension Data Memory EM	-----	EM00000 - EM65534		Bit 15
Extension Data Memory FM	-----	FM00000 - FM32766		Bit 15
Temporary Data Memory	-----	TM000 - TM511		Bit 15
Control Memory	-----	CM00000 - CM11998		Bit 15
Index Register	-----	Z01 - Z12		Bit 15 *4
Digital Trimmer	-----	TRM0 - TRM7		*3
High-speed Counter (Current Value)	-----	CTH0 - CTH1		*3
High-speed Counter Comparator (Setting Value)	-----	CTC0 - CTC3		*3

*1 R000 to R599 (R00000 to R59915) are shown in KV-1000, but 000 to 599 (00000 to 59915) in GP-Pro EX.

*2 Write disable

*3 32-bit device

*4 Do not write to the addresses Z11 and Z12. They are used in the system of the External Device.

NOTE

- Refer to the GP-Pro EX Reference Manual for system data area.

Cf. GP-Pro EX Reference Manual "LS Area (Direct Access Method Area)"

- Refer to the precautions on manual notation for icons in the table.

 "Manual Symbols and Terminology"

6.3 KV-3000/5000/5500 Series

 : This address can be specified as system data area.

Device		Bit Address	Word Address	32 bits	Remarks
Input Relay		R00000 - R99915	R000 - R999	L/H	
Output Relay					
Internal Auxiliary Relay					
Link Relay		B0000 - B3FFF	B000 - B3FF		
Internal Auxiliary Relay		MR00000 - MR99915	MR000 - MR999		
Latch Relay		LR00000 - LR99915	LR000 - LR999		
Control Relay		CR0000 - CR3915	CR00 - CR39		
Work Relay		VB0000 - VB3FFF	VB000 - VB3FF		
Timer (Contact)		T0000 - T3999	-----	-	
Counter (Contact)		C0000 - C3999	-----		
High-speed Counter Comparator (Contact)		CTC0 - CTC3	-----		*1
Timer (Setting Value)		-----	TS0000 - TS3999	L/H	*2
Counter (Setting Value)		-----	CS0000 - CS3999		*2
Timer (Current Value)		-----	TC0000 - TC3999		*2
Counter (Current Value)		-----	CC0000 - CC3999		*2
Data Memory		-----	DM00000 - DM65534		Bit 15
Extension Data Memory		-----	EM00000 - EM65534		Bit 15
File Register	Current Bank	-----	FM00000 - FM32767		Bit 15
	Serial Number System	-----	ZF000000 - ZF131071		Bit 15
Temporary Data Memory		-----	TM000 - TM511		Bit 15
Control Memory		-----	CM00000 - CM05999		Bit 15
Link Register		-----	W0000 - W3FFF	Bit F	
Work Memory		-----	VM00000 - VM59999	Bit 15	
Index Register		-----	Z01 - Z12	*2 *3	
Digital Trimmer		-----	TRM0 - TRM7	*2	
High-speed Counter (Current Value)		-----	CTH0 - CTH1	*2	
High-speed Counter Comparator (Setting Value)		-----	CTC0 - CTC3	*2	

*1 Write disable









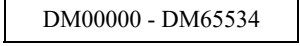

- *2 32-bit device
- *3 Do not write to the addresses Z11 and Z12. They are used in the system of the External Device.

NOTE

- Refer to the GP-Pro EX Reference Manual for system data area.
Cf. GP-Pro EX Reference Manual "LS Area (Direct Access Method Area)"
 - Refer to the precautions on manual notation for icons in the table.
 "Manual Symbols and Terminology"
-

6.4 KV-7000 Series

 : This address can be specified as system data area.

Device		Bit Address	Word Address	32 bits	Remarks
Input Relay		R000000 - R199915	R0000 - R1999		
Output Relay					
Internal Auxiliary Relay					
Link Relay		B0000 - B7FFF	B000 - B7FF		
Internal Auxiliary Relay		MR000000 - MR399915	MR0000 - MR3999		
Latch Relay		LR000000 - LR99915	LR000 - LR999		
Control Relay		CR0000 - CR7915	CR00 - CR79		
Work Relay		VB0000 - VBF9FF	VB000 - VBF9F		
Timer (Contact)		T0000 - T3999	-----	-	
Counter (Contact)		C0000 - C3999	-----		
Timer (Setting Value)		-----	TS0000 - TS3999		*1
Counter (Setting Value)		-----	CS0000 - CS3999		*1
Timer (Current Value)		-----	TC0000 - TC3999		*1
Counter (Current Value)		-----	CC0000 - CC3999		*1
Data Memory		-----	 DM00000 - DM65534		
Extension Data Memory		-----	EM00000 - EM65534		
File Register	Current Bank	-----	FM00000 - FM32767		
	Serial Number System	-----	ZF000000 - ZF524287		
Temporary Data Memory		-----	TM000 - TM511		
Control Memory		-----	CM0000 - CM5999		
Link Register		-----	W0000 - W7FFF		
Work Memory		-----	VM00000 - VM50999		
Index Register		-----	Z01 - Z12	*1*2	
Digital Trimmer		-----	TRM0 - TRM7	*1	

*1 32-bit device

*2 Do not write to the addresses Z11 and Z12. They are used in the system of the External Device.

NOTE

- Refer to the GP-Pro EX Reference Manual for system data area.

Cf. GP-Pro EX Reference Manual "LS Area (Direct Access Method Area)"

- Refer to the precautions on manual notation for icons in the table.

 "Manual Symbols and Terminology"

6.5 KV-Nano Series

 : This address can be specified as system data area.

Device	Bit Address	Word Address	32 bits	Remarks
Input Relay	R00000 - R59915	R000 - R599	L/H	
Output Relay				
Internal Auxiliary Relay				
Link Relay	B0000 - B1FFF	B000 - B1FF		
Internal Auxiliary Relay	MR00000 - MR59915	MR000 - MR599		
Latch Relay	LR00000 - LR19915	LR000 - LR199		
Control Relay	CR0000 - CR8915	CR00 - CR89		
Work Relay	VB0000 - VB1FFF	VB000 - VB1FF		
Timer (Contact)	T000 - T511	-----	-	
Counter (Contact)	C000 - C255	-----		
High-speed Counter Comparator (Contact)	CTC0 - CTC7	-----		*1
Timer (Setting Value)	-----	TS000 - TS511	L/H	*2
Counter (Setting Value)	-----	CS000 - CS255		*2
Timer (Current Value)	-----	TC000 - TC511		*2
Counter (Current Value)	-----	CC000 - CC255		*2
Data Memory	-----	DM00000 - DM32767		Bit 15
Temporary Data Memory	-----	TM000 - TM511		Bit 15
Control Memory	-----	CM0000 - CM8999		Bit 15
Link Register	-----	W0000 - W3FFF		Bit F
Work Memory	-----	VM0000 - VM9499		Bit 15
Index Register	-----	Z01 - Z12		*2*3
High-speed Counter (Current Value)	-----	CTH0 - CTH3		*2*4
High-speed Counter Comparator (Setting Value)	-----	CTC0 - CTC7		*2*5

*1 Write disable

*2 32-bit device

*3 Do not write to the addresses Z11 and Z12. They are used in the system of the External Device.

*4 In the case of KV-NC32T, the maximum value of the address is CTH2. Reading of CTH3 is not a read error, but the value will be 0. If the written, it will write error.

*5 In the case of KV-NC32T, the maximum value of the address is CTC5. Reading of CTC6 and CTC7 is not a read error, but the value will be 0. If the written, it will write error.

NOTE

- Refer to the GP-Pro EX Reference Manual for system data area.









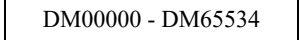

Cf. GP-Pro EX Reference Manual "LS Area (Direct Access Method Area)"

- Refer to the precautions on manual notation for icons in the table.

 "Manual Symbols and Terminology"

6.6 KV-8000 Series

 : This address can be specified as system data area.

Device		Bit Address	Word Address	32 bits	Remarks
Input Relay		R000000 - R199915	R0000 - R1999		
Output Relay					
Internal Auxiliary Relay					
Link Relay		B0000 - B7FFF	B000 - B7FF		
Internal Auxiliary Relay		MR000000 - MR399915	MR0000 - MR3999		
Latch Relay		LR000000 - LR99915	LR000 - LR999		
Control Relay		CR0000 - CR7915	CR00 - CR79		
Work Relay		VB0000 - VBF9FF	VB000 - VBF9F		
Timer (Contact)		T0000 - T3999	-----	-	
Counter (Contact)		C0000 - C3999	-----		
Timer (Setting Value)		-----	TS0000 - TS3999		*1
Counter (Setting Value)		-----	CS0000 - CS3999		*1
Timer (Current Value)		-----	TC0000 - TC3999		*1
Counter (Current Value)		-----	CC0000 - CC3999		*1
Data Memory		-----	 DM00000 - DM65534		
Extension Data Memory		-----	EM00000 - EM65534		
File Register	Current Bank	-----	FM00000 - FM32767		
	Serial Number System	-----	ZF000000 - ZF524287		
Temporary Data Memory		-----	TM000 - TM511		
Control Memory		-----	CM0000 - CM7599		
Link Register		-----	W0000 - W7FFF		
Work Memory		-----	VM000000 - VM589823		
Index Register		-----	Z01 - Z12	*1*2	
Digital Trimmer		-----	TRM0 - TRM7	*1	

*1 32-bit device

*2 Do not write to the addresses Z11 and Z12. They are used in the system of the External Device.

NOTE • Refer to the GP-Pro EX Reference Manual for system data area.

Cf. GP-Pro EX Reference Manual "LS Area (Direct Access Method Area)"

• Refer to the precautions on manual notation for icons in the table.

 "Manual Symbols and Terminology"

7 Device Code and Address Code

Use device code and address code if you select "Device Type & Address" for the address type in Data displays.

7.1 KV-700 Series

Device	Device Name	Device Code (HEX)	Address Code
Input Relay	-----	0080	Word Address
Output Relay			
Internal Auxiliary Relay			
Control Relay	CR	008A	Word Address
Timer (Setting Value)	TS	0062	Double Word Address
Counter (Setting Value)	CS	0063	Double Word Address
Timer (Current Value)	TC	0060	Double Word Address
Counter (Current Value)	CC	0061	Double Word Address
Data Memory	DM	0000	Word Address
Temporary Data Memory	TM	0001	Word Address
Control Memory	CM	0002	Word Address
Digital Trimmer	TRM	0064	Double Word Address
High-speed Counter (Current Value)	CTH	0065	Double Word Address
High-speed Counter Comparator (Setting Value)	CTC	0066	Double Word Address

7.2 KV-1000 Series

Device	Device Name	Device Code (HEX)	Address Code
Input Relay	-----	0080	Word Address
Output Relay			
Internal Auxiliary Relay			
Internal Auxiliary Relay	MR	0082	Word Address
Latch Relay	LR	0084	Word Address
Control Relay	CR	008A	Word Address
Timer (Setting Value)	TS	0062	Double Word Address
Counter (Setting Value)	CS	0063	Double Word Address
Timer (Current Value)	TC	0060	Double Word Address
Counter (Current Value)	CC	0061	Double Word Address
Data Memory	DM	0000	Word Address
Extension Data Memory	EM	0010	Word Address
Extension Data Memory	FM	0011	Word Address
Temporary Data Memory	TM	0001	Word Address
Control Memory	CM	0002	Word Address
Index Register	Z	0003	Word Address
Digital Trimmer	TRM	0064	Double Word Address
High-speed Counter (Current Value)	CTH	0065	Double Word Address
High-speed Counter Comparator (Setting Value)	CTC	0066	Double Word Address

7.3 KV-3000/5000/5500 Series

Device		Device Name	Device Code (HEX)	Address Code
Input Relay		R	0080	Word Address
Output Relay				
Internal Auxiliary Relay				
Link Relay		B	008B	Word Address
Internal Auxiliary Relay		MR	0082	Word Address
Latch Relay		LR	0084	Word Address
Control Relay		CR	008A	Word Address
Work Relay		VB	008C	Word Address
Timer (Setting Value)		TS	0062	Double Word Address
Counter (Setting Value)		CS	0063	Double Word Address
Timer (Current Value)		TC	0060	Double Word Address
Counter (Current Value)		CC	0061	Double Word Address
Data Memory		DM	0000	Word Address
Extension Data Memory		EM	0010	Word Address
File Register	Current Bank	FM	0011	Word Address
	Serial Number System	ZF	0012	Word Address
Temporary Data Memory		TM	0001	Word Address
Control Memory		CM	0002	Word Address
Link Register		W	0013	Word Address
Work Memory		VM	0014	Word Address
Index Register		Z	0067	Double Word Address
Digital Trimmer		TRM	0064	Double Word Address
High-speed Counter (Current Value)		CTH	0065	Double Word Address
High-speed Counter Comparator (Setting Value)		CTC	0066	Double Word Address

7.4 KV-7000 Series

Device		Device Name	Device Code (HEX)	Address Code
Input Relay		R	0080	Word Address
Output Relay				
Internal Auxiliary Relay				
Link Relay		B	008B	Word Address
Internal Auxiliary Relay		MR	0082	Word Address
Latch Relay		LR	0084	Word Address
Control Relay		CR	008A	Word Address
Work Relay		VB	008C	Word Address
Timer (Setting Value)		TS	0062	Double Word Address
Counter (Setting Value)		CS	0063	Double Word Address
Timer (Current Value)		TC	0060	Double Word Address
Counter (Current Value)		CC	0061	Double Word Address
Data Memory		DM	0000	Word Address
Temporary Data Memory		EM	0010	Word Address
File Register	Current Bank	FM	0011	Word Address
	Serial Number System	ZF	0012	Word Address
Temporary Data Memory		TM	0001	Word Address
Control Memory		CM	0002	Word Address
Link Register		W	0013	Word Address
Work Memory		VM	0014	Word Address
Index Register		Z	0067	Double Word Address
Digital Trimmer		TRM	0064	Double Word Address

7.5 KV-Nano Series

Device	Device Name	Device Code (HEX)	Address Code
Input Relay	R	0080	Word Address
Output Relay			
Internal Auxiliary Relay			
Link Relay	B	008B	Word Address
Internal Auxiliary Relay	MR	0082	Word Address
Latch Relay	LR	0084	Word Address
Control Relay	CR	008A	Word Address
Work Relay	VB	008C	Word Address
Timer (Setting Value)	TS	0062	Double Word Address
Counter (Setting Value)	CS	0063	Double Word Address
Timer (Current Value)	TC	0060	Double Word Address
Counter (Current Value)	CC	0061	Double Word Address
Data Memory	DM	0000	Word Address
Temporary Data Memory	TM	0001	Word Address
Control Memory	CM	0002	Word Address
Link Register	W	0013	Word Address
Work Memory	VM	0014	Word Address
Index Register	Z	0067	Double Word Address
High-speed Counter (Current Value)	CTH	0065	Double Word Address
High-speed Counter Comparator (Setting Value)	CTC	0066	Double Word Address

7.6 KV-8000 Series

Device		Device Name	Device Code (HEX)	Address Code
Input Relay		R	0080	Word Address
Output Relay				
Internal Auxiliary Relay				
Link Relay		B	008B	Word Address
Internal Auxiliary Relay		MR	0082	Word Address
Latch Relay		LR	0084	Word Address
Control Relay		CR	008A	Word Address
Work Relay		VB	008C	Word Address
Timer (Setting Value)		TS	0062	Double Word Address
Counter (Setting Value)		CS	0063	Double Word Address
Timer (Current Value)		TC	0060	Double Word Address
Counter (Current Value)		CC	0061	Double Word Address
Data Memory		DM	0000	Word Address
Temporary Data Memory		EM	0010	Word Address
File Register	Current Bank	FM	0011	Word Address
	Serial Number System	ZF	0012	Word Address
Temporary Data Memory		TM	0001	Word Address
Control Memory		CM	0002	Word Address
Link Register		W	0013	Word Address
Work Memory		VM	0014	Word Address
Index Register		Z	0067	Double Word Address
Digital Trimmer		TRM	0064	Double Word Address

8 Error Messages

Error messages are displayed on the Display screen as follows: "No.: Device Name: Error Message (Error Occurrence Area)". Each description is shown below.

Item	Description
No.	Error No.
Device Name	Name of the External Device where an error has occurred. Device name is a title of the External Device set with GP-Pro EX. (Initial value [PLC1])
Error Message	Displays messages related to an error that has occurred.
Error Occurrence Area	Displays the IP address or device address of the External Device where an error has occurred, or error codes received from the External Device. NOTE <ul style="list-style-type: none"> • IP address is displayed as "IP address (Decimal): MAC address (Hex)". • Device address is displayed as "Address: Device address". • Received error codes are displayed as "Decimal [Hex]".

Display Examples of Error Messages

"RHAA035: PLC1: Error has been responded for device write command (Error Code: 1 [01H])"

NOTE

- Refer to your External Device manual for details on received error codes.
- Refer to "Display-related errors" in "Maintenance/Troubleshooting Manual" for details on the error messages common to the driver.

◆ Error Codes Specific to the External Device

Error Code (HEX)	Error Description
02	Executed illegal access. ² Wrote in the write disable device. ² Accessed the nonexistent device or address.
04	Tried to communicate in the communication baud rate not supported by the External Device.
31	Accessed the device not defined as device in the External Device.* ¹
0B	Performed monitor read with the monitor unregistered.

*1 Setup in the ladder program is required before accessing the Timer (Contact/Current Value/Setting Value), Counter (Contact/Current Value/Setting Value), High-speed Counter (Current Value) and High-speed Counter Comparator (Setting Value).

