



# MODBUS SIO Master Driver

1	System Configuration.....	3
2	External Devices Selection .....	8
3	Communication Settings .....	9
4	Setup Items .....	17
5	Cable Diagrams .....	22
6	Supported Devices.....	38
7	Device Code and Address Code.....	42
8	Error Messages.....	43

## Introduction

This manual describes how to connect the Display and the External Device (target PLC).

In this manual, the connection procedure is described in the sections identified below:

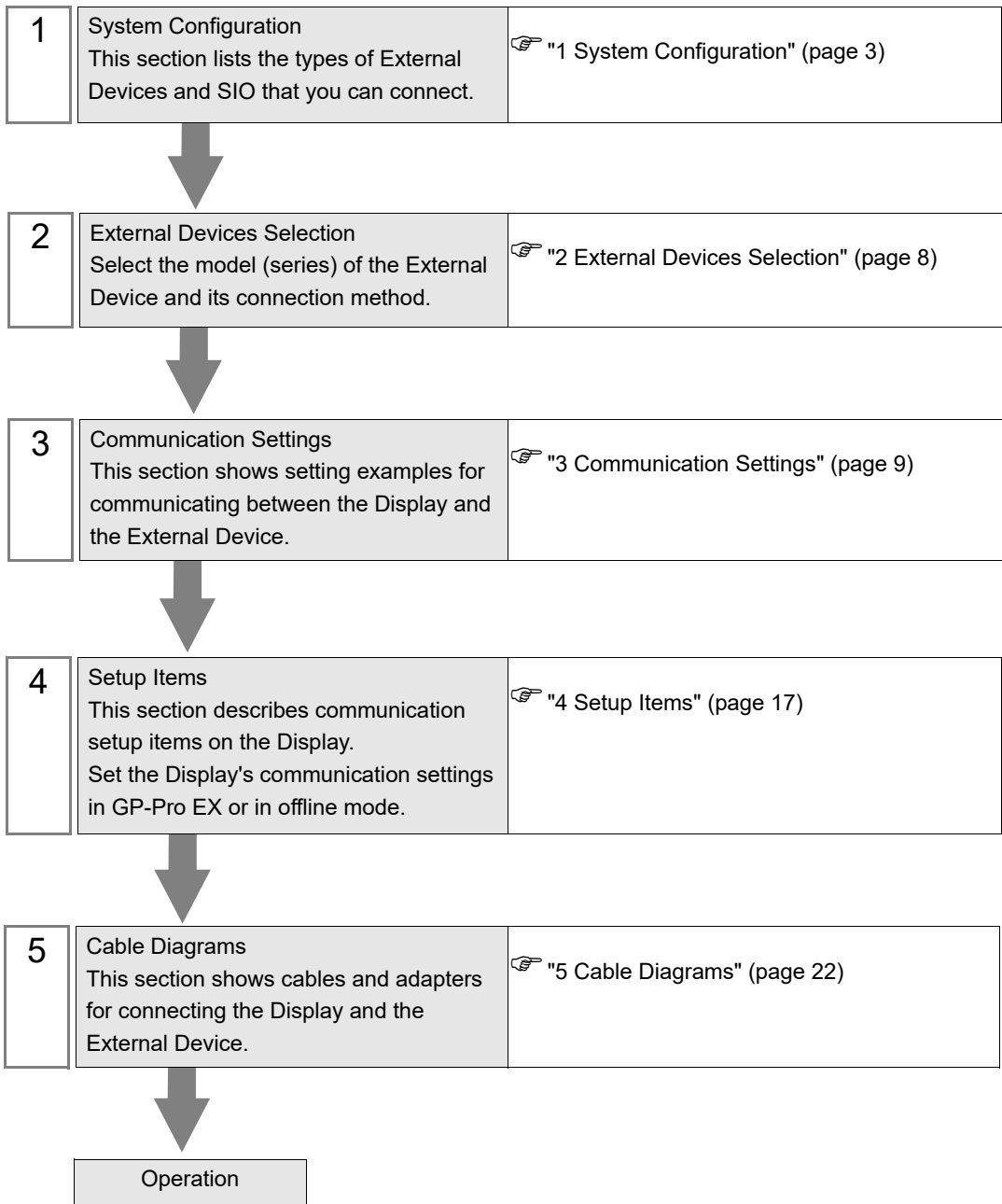

# 1 System Configuration

The following table lists system configurations for connecting a MODBUS-compatible External Device and the Display.

Series	CPU	Link I/F	SIO Type	Setting Example	Cable Diagrams
NX Series	NX-D15□□□□□□ NX-D25□□□□□□ NX-D35□□□□□□	RS-485 communication terminal on the base	RS-422/485 (2 wire)	Setting Example 1 (page 9)	Cable Diagram 1 (page 22)
		RS-485 communication terminal on NX-CB1□□□□□□	RS-422/485 (2 wire)	Setting Example 1 (page 9)	Cable Diagram 1 (page 22)
		RS-232C connector on CMC10L	RS-232C	Setting Example 2 (page 11)	Cable Diagram 2 (page 35)
K1G Series	K1G-C04	RS-485 communications terminal on rear side of CPU Unit	RS-422/485 (2 wire)	Setting Example 3 (page 13)	Cable Diagram 1 (page 22)
C1M Series	C1MT□□□□03□□ C1MT□□□□06□□ C1MT□□□□09□□	Terminal block on the CPU	RS-422/485 (2 wire)	Setting Example 4 (page 15)	Cable Diagram 3 (page 37)

## ■ Connection Configuration

### ◆ 1:1 Connection

- Direct Connection

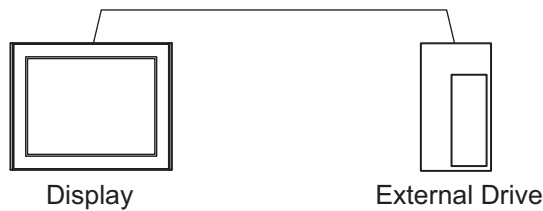

- Using CMC10L

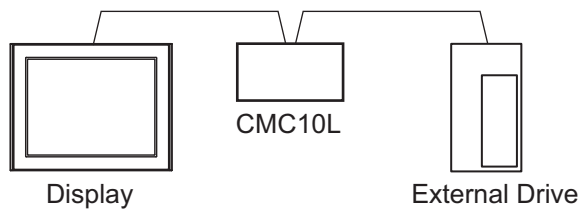

◆ 1:n Connection

- Using 1 port

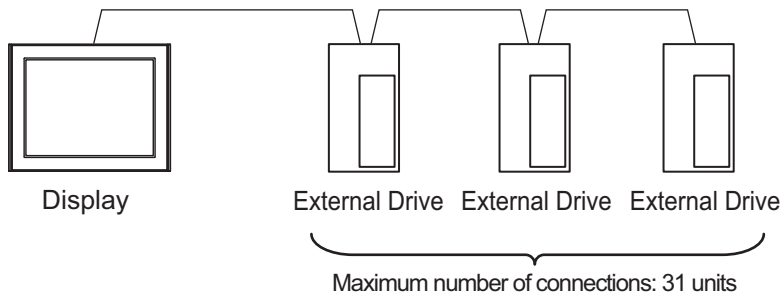

- Using 1 port (when connecting External Devices)

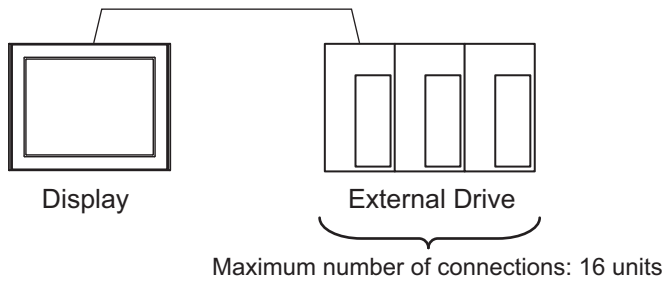

- Using 1 port (when using CMC10L)

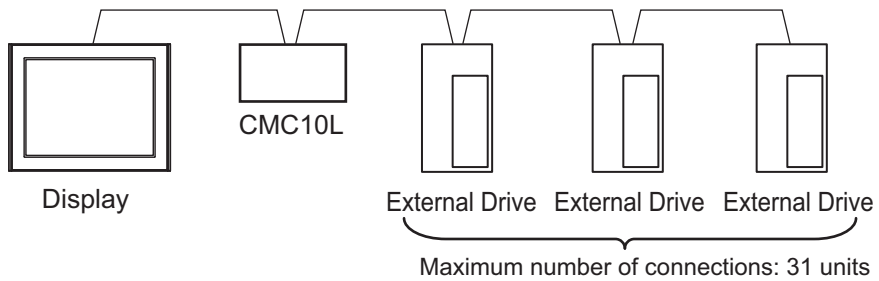

- Using 2 or more ports

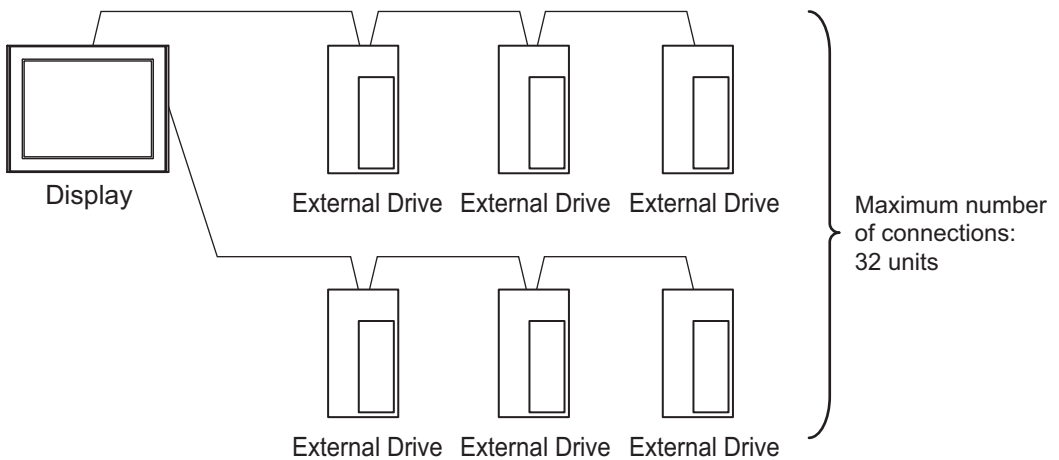

## ■ IPC COM Port

When connecting IPC with an External Device, the COM port used depends on the series and SIO type. Please refer to the IPC manual for details.

### Usable port

Series	Usable Port		
	RS-232C	RS-422/485(4 wire)	RS-422/485(2 wire)
PS-2000B	COM1 <sup>*1</sup> , COM2, COM3 <sup>*1</sup> , COM4	-	-
PS-3450A, PS-3451A, PS3000-BA, PS3001-BD	COM1, COM2 <sup>*1*2</sup>	COM2 <sup>*1*2</sup>	COM2 <sup>*1*2</sup>
PS-3650A (T41 model), PS-3651A (T41 model)	COM1 <sup>*1</sup>	-	-
PS-3650A (T42 model), PS-3651A (T42 model)	COM1 <sup>*1*2</sup> , COM2	COM1 <sup>*1*2</sup>	COM1 <sup>*1*2</sup>
PS-3700A (Pentium®4-M) PS-3710A	COM1 <sup>*1</sup> , COM2 <sup>*1</sup> , COM3 <sup>*2</sup> , COM4	COM3 <sup>*2</sup>	COM3 <sup>*2</sup>
PS-3711A	COM1 <sup>*1</sup> , COM2 <sup>*2</sup>	COM2 <sup>*2</sup>	COM2 <sup>*2</sup>
PS4000 <sup>*3</sup>	COM1, COM2	-	-
PL3000	COM1 <sup>*1*2</sup> , COM2 <sup>*1</sup> , COM3, COM4	COM1 <sup>*1*2</sup>	COM1 <sup>*1*2</sup>
PE-4000B Atom N270	COM1, COM2	-	-
PE-4000B Atom N2600	COM1, COM2	COM3 <sup>*4</sup> , COM4 <sup>*4</sup> , COM5 <sup>*4</sup> , COM6 <sup>*4</sup>	COM3 <sup>*4</sup> , COM4 <sup>*4</sup> , COM5 <sup>*4</sup> , COM6 <sup>*4</sup>
PS5000 (Slim Panel Type Core i3 Model) <sup>*5*6</sup>	COM1, COM2 <sup>*4</sup>	COM2 <sup>*4</sup>	COM2 <sup>*4</sup>
PS5000 (Slim Panel Type Atom Model) <sup>*5*6</sup>	COM1, COM2 <sup>*7</sup>	COM2 <sup>*7</sup>	COM2 <sup>*7</sup>
PS5000 (Enclosed Panel Type) <sup>*8</sup>	COM1	-	-
PS5000 (Modular Type PFXPU/PFXPP) <sup>*5*6</sup> PS5000 (Modular Type PFXPL2B5-6)	COM1 <sup>*7</sup>	COM1 <sup>*7</sup>	COM1 <sup>*7</sup>
PS5000 (Modular Type PFXPL2B1-4)	COM1, COM2 <sup>*7</sup>	COM2 <sup>*7</sup>	COM2 <sup>*7</sup>
PS6000	COM1 <sup>*9</sup>	<sup>*10</sup>	<sup>*10</sup>

\*1 The RI/5V can be switched. Use the IPC's switch to change if necessary.

\*2 Set up the SIO type with the DIP Switch. Please set up as follows according to SIO type to be used.

\*3 When making communication between an External Device and COM port on the Expansion slot, only RS-232C is supported. However, ER (DTR/CTS) control cannot be executed because of the specification of COM port.

For connection with External Device, use user-created cables and disable Pin Nos. 1, 4, 6 and 9. Please refer to the IPC manual for details of pin layout.

\*4 Set up the SIO type with the BIOS. Please refer to the IPC manual for details of BIOS.

- \*5 When setting up communication between an External Device and the RS-232C/422/485 interface module, use the IPC (RS-232C) or PS5000 (RS-422/485) cable diagrams. However, when using PFXZPBMPR42P2 in a RS-422/485 (4-wire) configuration with no flow control, connect 7.RTS+ and 8.CTS+, and connect 6.RTS- and 9.CTS-.  
When using RS-422/485 communication with External Devices, you may need to reduce the transmission speed and increase the TX Wait time.
- \*6 To use RS-422/485 communication on the RS-232C/422/485 interface module, the DIP Switch setting is required. Please refer to "Knowledge Base" (FAQs) on the support site. (<http://www.pro-face.com/trans/en/manual/1001.html>)

Settings	FAQ ID
PFXZPBMPR42P2, RS422/485 change method	FA263858
PFXZPBMPR42P2 termination resistor setting	FA263974
PFXZPBMPR44P2, RS422/485 change method	FA264087
PFXZPBMPR44P2 termination resistor setting	FA264088

- \*7 Set up the SIO type with the DIP Switch. Please refer to the IPC manual for details of DIP Switch. The BOX Atom has not a switch to set the RS-232C, RS-422/485 mode. Use the BIOS for the setting.
- \*8 For the connection with the External Device, on the user-created cable read as if the connector on the Display-side is a M12 A-coding 8 pin socket. The pin assignment is the same as described in the cable diagram. For the M12 A-coding connector, use PFXZPSCNM122.
- \*9 In addition to COM1, you can also use the RS-232C COM port on the optional interface.
- \*10 Install the optional interface in the expansion slot.

DIP Switch settings (PL3000 / PS3000 Series)

RS-232C

DIP Switch	Setting	Description
1	OFF*1	Reserved (always OFF)
2	OFF	SIO type: RS-232C
3	OFF	
4	OFF	Output mode of SD (TXD) data: Always output
5	OFF	Terminal resistance (220Ω) insertion to SD (TXD): None
6	OFF	Terminal resistance (220Ω) insertion to RD (RXD): None
7	OFF	Short-circuit of SDA (TXA) and RDA (RXA): Not available
8	OFF	Short-circuit of SDB (TXB) and RDB (RXB): Not available
9	OFF	RS (RTS) Auto control mode: Disabled
10	OFF	

\*1 When using PS-3450A, PS-3451A, PS3000-BA and PS3001-BD, turn ON the set value.

## RS-422/485 (4 wire)

DIP Switch	Setting	Description
1	OFF	Reserved (always OFF)
2	ON	SIO type: RS-422/485
3	ON	
4	OFF	Output mode of SD (TXD) data: Always output
5	OFF	Terminal resistance (220Ω) insertion to SD (TXD): None
6	OFF	Terminal resistance (220Ω) insertion to RD (RXD): None
7	OFF	Short-circuit of SDA (TXA) and RDA (RXA): Not available
8	OFF	Short-circuit of SDB (TXB) and RDB (RXB): Not available
9	OFF	RS (RTS) Auto control mode: Disabled
10	OFF	

## RS-422/485 (2 wire)

DIP Switch	Setting	Description
1	OFF	Reserved (always OFF)
2	ON	SIO type: RS-422/485
3	ON	
4	OFF	Output mode of SD (TXD) data: Always output
5	OFF	Terminal resistance (220Ω) insertion to SD (TXD): None
6	OFF	Terminal resistance (220Ω) insertion to RD (RXD): None
7	ON	Short-circuit of SDA (TXA) and RDA (RXA): Available
8	ON	Short-circuit of SDB (TXB) and RDB (RXB): Available
9	ON	RS (RTS) Auto control mode: Enabled
10	ON	

## 2 External Devices Selection

Select the External Device to be connected to the Display.

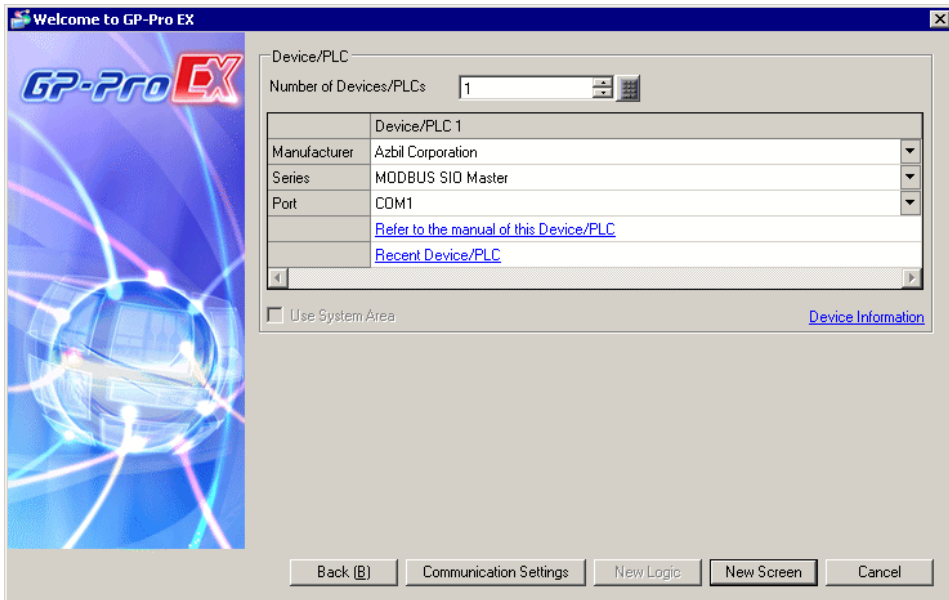

Setup Items	Setup Description
Number of Devices/PLCs	Enter an integer from 1 to 4 to define the number of Devices/PLCs to connect to the display.
Manufacturer	Select the manufacturer of the External Device to connect. Select "Azbil Corporation".
Series	Select the External Device model (series) and the connection method. Select "MODBUS SIO Master". In System configuration, make sure the External Device you are connecting is supported by "MODBUS SIO Master". ☞ "1 System Configuration" (page 3)
Port	Select the Display port to be connected to the External Device.
Use System Area	Not available in this driver.



### 3 Communication Settings

This section provides examples of communication settings recommended by Pro-face for the Display and the External Device.

#### 3.1 Setting Example 1

##### ■ Settings of GP-Pro EX

##### ◆ Communication Settings

To display the setup screen, from the [Project] menu, point to [System Settings] and select [Device/PLC].

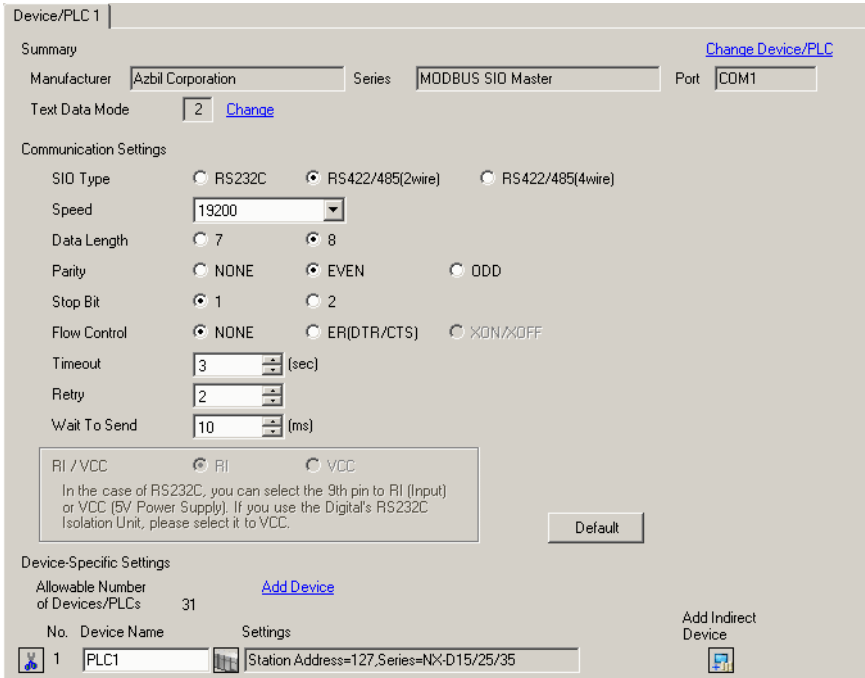

##### ◆ Device Setting

To display the [Individual Device Settings] dialog box, from [Device-Specific Settings] in the [Device/PLC] window, select the external device and click [Settings].

To connect multiple External Devices, from [Device-Specific Settings] in the [Device/PLC] window, click [Add Device] to add another External Device.

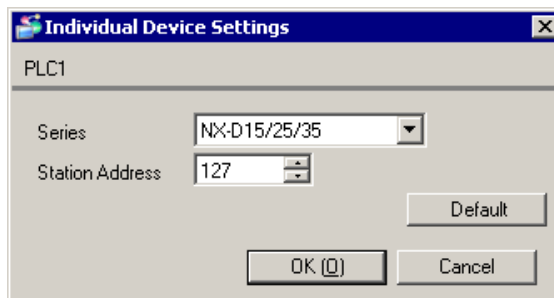

## ■ External Device Settings

Use Smart Loader Package (SLP-NX) for the External Device communication settings.

Refer to your External Device manual for details.

- 1 Start Smart Loader Package.
- 2 From the [Online] menu, select [Actual Module Configuration].
- 3 Click the [Edit] button on the [General] tab.
- 4 Click the [Communication Setting] button.
- 5 Select the [RS-485 Detail Settings] tab, and set as shown below:

Setup Items	Setting
RS-485 Station address	127
RS-485 CPL/MODBUS	MODBUS RTU
RS-485 Transmission Speed	19200bps
RS-485 Data Length	8 bits
RS-485 Parity	Even parity
RS-485 Stop Bit	1 Bits
RS-485 Response time-out	3

- 6 Click the [OK] button.
- 7 Click the [Write] button, and send the settings to the External Device.

### 3.2 Setting Example 2

#### ■ Settings of GP-Pro EX

##### ◆ Communication Settings

To display the setup screen, from the [Project] menu, point to [System Settings] and select [Device/PLC].

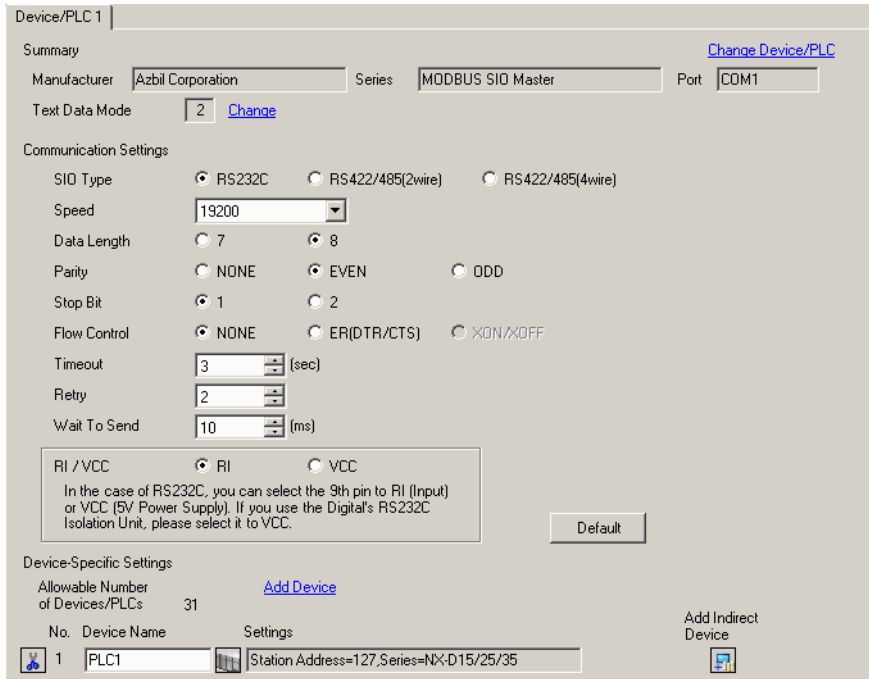

##### ◆ Device Setting

To display the [Individual Device Settings] dialog box, from [Device-Specific Settings] in the [Device/PLC] window, select the external device and click [Settings] .

To connect multiple External Devices, from [Device-Specific Settings] in the [Device/PLC] window, click [Add Device] to add another External Device.

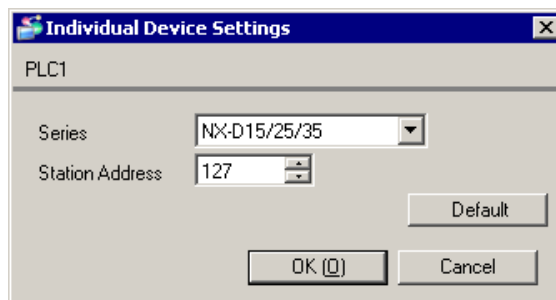

## ■ External Device Settings

Use Smart Loader Package (SLP-NX) and the CMC10L DIP Switch for the External Device communication settings.

Refer to your External Device manual for details.

### ◆ External Device Communication Settings

- 1 Start Smart Loader Package.
- 2 From the [Online] menu, select [Actual Module Configuration].
- 3 Click the [Edit] button on the [General] tab.
- 4 Click the [Communication Setting] button.
- 5 Select the [RS-485 Detail Settings] tab, and set as shown below:

Setup Items	Setting
RS-485 Station address	127
RS-485 CPL/MODBUS	MODBUS RTU
RS-485 Transmission Speed	19200bps
RS-485 Data Length	8 bits
RS-485 Parity	Even parity
RS-485 Stop Bit	1 Bits
RS-485 Response time-out	3

- 6 Click the [OK] button.
- 7 Click the [Write] button, and send the settings to the External Device.

### ◆ CMC10L (Link I/F) Communication Settings

Set the CMC10L DIP Switch as shown below.

- DIP Switch

Switch No.	Setting	Setup Description
1	OFF	19200
2	ON	
3	ON	
4	ON	1 character 11 bits
5	ON	
6	OFF	
7	ON	LED ON: Power ON
8	ON	Termination Resistance 150 Ω

- Mode selector switch

Switch	Setting
Mode selector switch	TERMINAL

### 3.3 Setting Example 3

#### ■ Settings of GP-Pro EX

##### ◆ Communication Settings

To display the setup screen, from the [Project] menu, point to [System Settings] and select [Device/PLC].

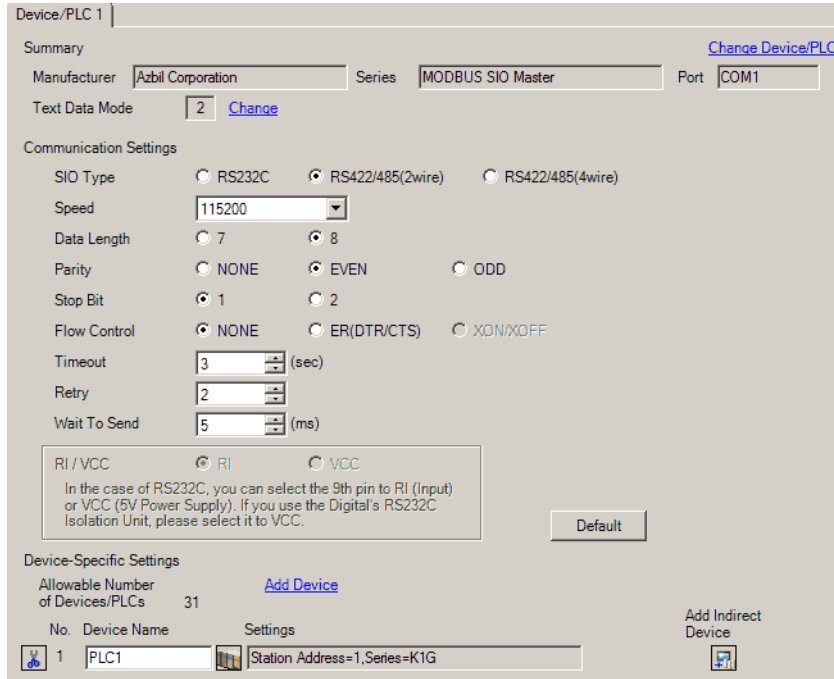

##### ◆ Device Setting

To display the [Individual Device Settings] dialog box, from [Device-Specific Settings] in the [Device/PLC] window, select the external device and click [Settings] .

To connect multiple External Devices, from [Device-Specific Settings] in the [Device/PLC] window, click [Add Device] to add another External Device.

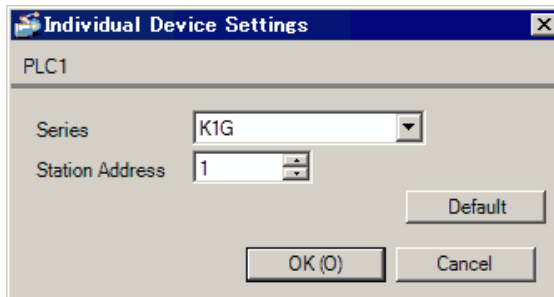

## ■ External Device Settings

To configure communication settings for the External Device, use the CPU unit's Run, para, enter and cursor keys. Refer to your External Device manual for details.

### ◆ Procedure

- 1 When [Run] is lit, press and hold the Run key for 3 seconds.
- 2 Press the para key to display parameters.
- 3 Use the up/down cursor keys to display the setup items. (Setup items will blink.)
- 4 Press the enter key to select a setup item.
- 5 Select the settings with the cursor keys. (Settings will blink.)
- 6 Press the enter key to confirm the settings.
- 7 Press the Run key, and [Run] is lit.

### ◆ Settings

Setup Items	Settings	Setup Description
A06	1	Device address
A07	115.2	Speed
A08	EVEn	Even parity, 1 stop bit

### 3.4 Setting Example 4

#### ■ Settings of GP-Pro EX

##### ◆ Communication Settings

To display the setup screen, from the [Project] menu, point to [System Settings] and select [Device/PLC].

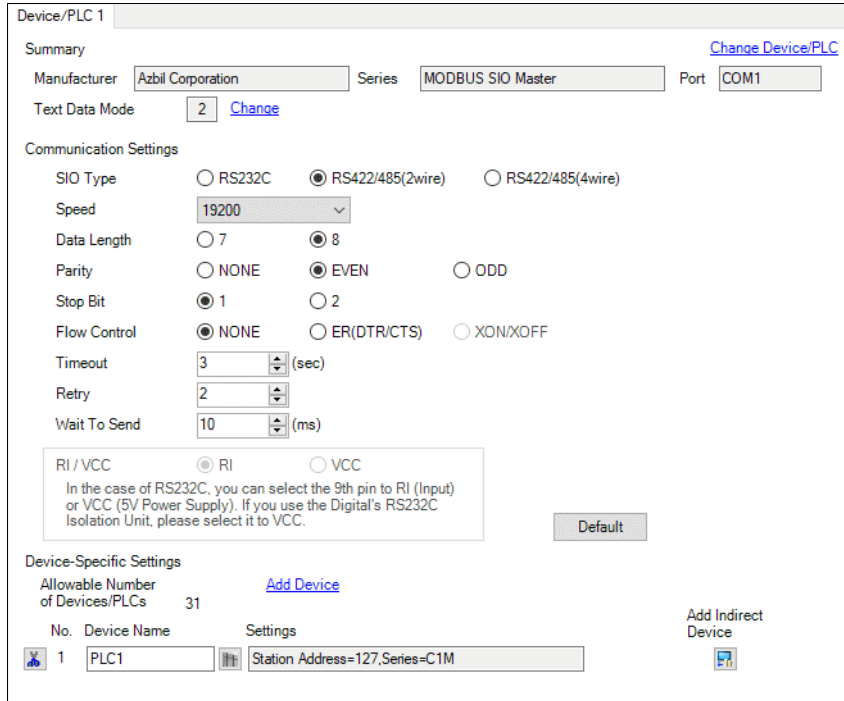

##### ◆ Device Setting

To display the [Individual Device Settings] dialog box, from [Device-Specific Settings] in the [Device/PLC] window, select the external device and click [Settings] .

To connect multiple External Devices, from [Device-Specific Settings] in the [Device/PLC] window, click [Add Device] to add another External Device.

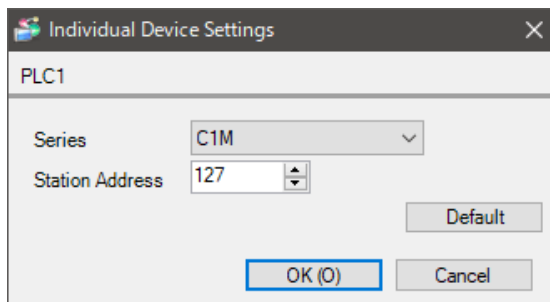

## ■ Settings of External Device

To configure communication settings for the External Device, use the Operation Panel on the front of the Controller or the ladder software (SLP-C1F v1.4.1).

Refer to your Controller manual for details.

- Operation Panel

- 1 In the operation display, press and hold the PARA key (for 2 seconds) to move to the Bank selection display.
- 2 In the Bank selection display, press and hold the PARA key (for 2 seconds) to move to the Setup bank selection display.
- 3 Press the PARA key several times to display the following setup item.
- 4 Use the Down/Up keys to select a setting.  
The set value will blink.  
When no operation is performed for 2 seconds, the set value stops blinking and the change is fixed.
- 5 After setting, press and hold the PARA key (for 2 seconds) or press the MODE key to move to the operation display.

- Ladder software

- 1 Connect the loader cable to the loader connector on the External Device.  
Use SIO-USB adapter if necessary.
- 2 Start up the ladder software.
- 3 Select [Menu] - [Option(E)].
- 4 Select the communication port to use.
- 5 Select [Standard] - [Setup(Comm)].
- 6 Set the following setup item.
- 7 After setting, click [Write(SLP->C1M)] or [Communication] - [Write(SLP->C1M)].

### ◆ Settings

Setup items	Display	Initial value	Settings	Setup Description
Communication type	C64	0	2	Modbus/RTU
Station address	C65	0	1	Set the same value as the Device Address set in the Display's Individual Device Settings.
Transmission speed	C66	2	3	38400 bps
Dara format (data length)	C67	1	1	8 bits
Dara format (parity)	C68	0	0	Even parity
Data format (stop bit)	C69	0	0	1 bit
Communication minimum response time	C70	3	3	3 ms



## 4 Setup Items

Set up the Display's communication settings in GP-Pro EX or in the Display's offline mode.

The setting of each parameter must match that of the External Device.

"3 Communication Settings" (page 9)

### 4.1 Setup Items in GP-Pro EX

#### ■ Communication Settings

To display the setup screen, from the [Project] menu, point to [System Settings] and select [Device/PLC].

Device/PLC 1

Summary [Change Device/PLC](#)

Manufacturer  Series  Port

Text Data Mode  [Change](#)

Communication Settings

SIO Type  RS232C  RS422/485(2wire)  RS422/485(4wire)

Speed

Data Length  7  8

Parity  NONE  EVEN  ODD

Stop Bit  1  2

Flow Control  NONE  ER(DTR/CTS)  XON/XOFF

Timeout  (sec)

Retry

Wait To Send  (ms)

RI / VCC  RI  VCC

In the case of RS232C, you can select the 9th pin to RI (Input) or VCC (5V Power Supply). If you use the Digital's RS232C Isolation Unit, please select it to VCC.

Device-Specific Settings

Allowable Number of Devices/PLCs  [Add Device](#)

No.	Device Name	Settings	Add Indirect Device
1	PLC1	Station Address=127, Series=NX-D15/25/35	

Setup Items	Setup Description
SIO Type	Select the SIO type to communicate with the External Device. <b>IMPORTANT</b> In the communication settings, set [SIO Type] correctly according to the serial interface specifications of the Display. If you select an SIO type that the serial interface does not support, proper operation cannot be guaranteed. Refer to your Display manual for details on the serial interface specifications.
Speed	Select the communication speed between the External Device and the Display.
Data Length	Select the data length.
Parity	Select how to check parity.
Stop Bit	Select the stop bit length.
Flow Control	Select the communication control method to prevent overflow of transmission and reception data.

Continues to the next page.

Setup Items	Setup Description
Timeout	Enter the time (seconds) for which the Display waits for the response from the External Device, from 1 to 127.
Retry	In case of no response from the External Device, enter how many times the Display retransmits the command, from 0 to 255.
Wait To Send	Enter the standby time (milliseconds) from when the Display receives packets until it transmits the next command, from 0 to 5000.
RI/VCC	When you select RS232C as the SIO Type, you can use pin 9 as either RI or VCC. When connecting to the IPC, to change between RI and 5V you need to use the IPC's changeover switch. Please refer to the IPC manual for more details.

**NOTE**

- Refer to the GP-Pro EX Reference Manual for Indirect Device.

Cf. GP-Pro EX Reference Manual "Changing the Device/PLC at Runtime (Indirect Device)"

## ■ Device Setting

To display the [Individual Device Settings] dialog box, from [Device-Specific Settings] in the [Device/PLC] window, select the external device and click [Settings] .

To connect multiple External Devices, from [Device-Specific Settings] in the [Device/PLC] window, click [Add Device] to add another External Device.

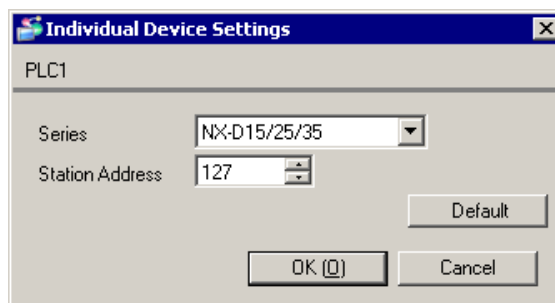

Setup Items	Setup Description
Series	Select the series of the External Device.
Station Address	Enter the address of the External Device, from 1 to 247.

## 4.2 Setup Items in Offline Mode

**NOTE**

- Refer to the Maintenance/Troubleshooting guide for information on how to enter offline mode or about the operation.

Cf. Maintenance/Troubleshooting Guide "Offline Mode"

- In offline mode, the number of settings you can view on one screen varies depending on the Display in use. Please refer to the Reference Manual for more details.

### ■ Communication Settings

To display the setting screen, touch [Device/PLC Settings] from [Peripheral Settings] in offline mode. Touch the External Device you want to set from the list that appears.

Comm.	Device	Option		
MODBUS SIO Master		[COM1]	Page 1/1	
SIO Type	RS422/485(2wire)			
Speed	19200			
Data Length	<input type="radio"/> 7 <input checked="" type="radio"/> 8			
Parity	<input type="radio"/> NONE <input checked="" type="radio"/> EVEN <input type="radio"/> ODD			
Stop Bit	<input checked="" type="radio"/> 1 <input type="radio"/> 2			
Flow Control	NONE			
Timeout(s)	3			
Retry	2			
Wait To Send(ms)	10			
Exit		Back		2010/05/11 16:16:56

Setup Items	Setup Description
SIO Type	Select the SIO type to communicate with the External Device. <b>IMPORTANT</b> In the communication settings, set [SIO Type] correctly according to the serial interface specifications of the Display. If you select an SIO type that the serial interface does not support, proper operation cannot be guaranteed. Refer to your Display manual for details on the serial interface specifications.
Speed	Select the communication speed between the External Device and the Display.
Data Length	Select the data length.
Parity	Select how to check parity.
Stop Bit	Select the stop bit length.
Flow Control	Select the communication control method to prevent overflow of transmission and reception data.

Continues to the next page.

Setup Items	Setup Description
Timeout	Enter the time (seconds) for which the Display waits for the response from the External Device, from 1 to 127.
Retry	In case of no response from the External Device, enter how many times the Display retransmits the command, from 0 to 255.
Wait To Send	Enter the standby time (milliseconds) from when the Display receives packets until it transmits the next command, from 0 to 5000.

### ■ Device Setting

To display the setting screen, touch [Device/PLC Settings] from [Peripheral Settings]. Touch the External Device you want to set from the displayed list, and touch [Device].

Comm.	Device	Option		
MODBUS SIO Master		[COM1]	Page 1/1	
Device/PLC Name		PLC1		
Series		NX-D15/25/35		
Station Address		127		
Exit		Back		2015/01/28 13:26:57

Setup Items	Setup Description
Device/PLC Name	Select the External Device to set. Device/PLC name is the title of the External Device set with GP-Pro EX. (Initial value [PLC1])
Series	Displays the model of the External Device.
Station Address	Enter the address of the External Device, from 1 to 247.

■ Options

To display the setting screen, touch [Device/PLC Settings] from [Peripheral Settings]. Touch the External Device you want to set from the list that appears, and touch [Option].

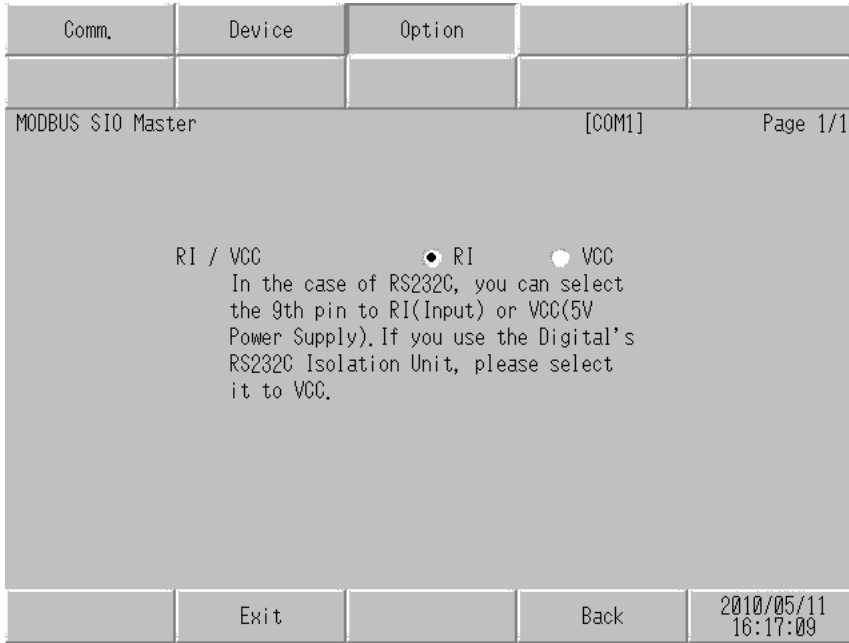

Setup Items	Setup Description
RI/VCC	When you select RS232C as the SIO Type, you can use pin 9 as either RI or VCC. When connecting to the IPC, to change between RI and 5V you need to use the IPC's changeover switch. Please refer to the IPC manual for more details.

**NOTE**

- GP-4100 series, GP-4\*01TM, GP-Rear Module, LT-4\*01TM and LT-Rear Module do not have the [Option] setting in the offline mode.

## 5 Cable Diagrams

The following cable diagrams may be different from cable diagrams recommended by Azbil Corporation. Please be assured there is no operational problem in applying the cable diagrams shown in this manual.

- The FG pin of the External Device body must be grounded according to your country's applicable standard. Refer to your External Device manual for details.
- SG and FG are connected inside the Display. When connecting the External Device to SG, design your system to avoid short-circuit loops.
- Connect an isolation unit if the communication is not stable due to noise or other factors.

Cable Diagram 1

Display (Connection Port)	Cable		Remarks
GP3000* <sup>1</sup> (COM1) AGP-3302B (COM2) GP-4*01TM (COM1) GP-Rear Module (COM1) ST3000* <sup>2</sup> (COM2) LT3000 (COM1)	1A	COM port conversion adapter by Pro-face CA3-ADPCOM-01 + Connector terminal block conversion adapter by Pro-face CA3-ADPTRM-01 + User created cable	Cable length: 500m or less
	1B	User created cable	
GP3000* <sup>3</sup> (COM2)	1C	Online adapter by Pro-face CA4-ADPONL-01 + Connector terminal block conversion adapter by Pro-face CA3-ADPTRM-01 + User created cable	Cable length: 500m or less
	1D	Online adapter by Pro-face CA4-ADPONL-01 + User created cable	
IPC* <sup>4</sup>	1E	COM port conversion adapter by Pro-face CA3-ADPCOM-01 + Connector terminal block conversion adapter by Pro-face CA3-ADPTRM-01 + User created cable	Cable length: 500m or less
	1F	User created cable	
GP-4106 (COM1) GP-4116T (COM1)	1G	User created cable	Cable length: 500m or less
GP-4107(COM1) GP-4*03T* <sup>5</sup> (COM2) GP-4203T (COM1)	1H	User created cable	Cable length: 500m or less

Display (Connection Port)	Cable		Remarks
GP4000* <sup>6</sup> (COM2) GP-4201T (COM1) SP5000* <sup>7</sup> (COM1/2) SP-5B00 (COM2) ST6000* <sup>8</sup> (COM2) ST-6200 (COM1) STM6000 (COM1)	1I	RS-422 Terminal Block Conversion Adapter by Pro-face PFXZCBADTM1* <sup>9</sup> + User-created cable	Cable length: 500m or less
	1B	User-created cable	
LT-4*01TM (COM1) LT-Rear Module (COM1)	1J	RJ45 RS-485 Cable (5m) by Pro-face PFXZLMCBRJ81	Cable length: 200m or less
PE-4000B* <sup>10</sup> PS5000* <sup>10</sup> PS6000* <sup>10</sup>	1K	User created cable	Cable length: 500m or less

\*1 All GP3000 models except AGP-3302B

\*2 Except AST-3211A and AST-3302B

\*3 All GP3000 models except the GP-3200 Series and AGP-3302B

\*4 You can only use COM ports that can communicate using RS-422/485 (2 wire). (Except PE-4000B, PS5000, and PS6000)

 ■ IPC COM Port (page 5)

\*5 Except GP-4203T

\*6 All GP4000 models except GP-4100 Series, GP-4\*01TM, GP-Rear Module, GP-4201T and GP-4\*03T

\*7 Except SP-5B00

\*8 Except ST-6200

\*9 When using a Terminal Block Conversion Adapter (CA3-ADPTRM-01) instead of the RS-422 Terminal Block Conversion Adapter, refer to Cable Diagram 1A.

\*10 You can only use COM ports that can communicate using RS-422/485 (2 wire).

 ■ IPC COM Port (page 5)

1A)

- 1:1 Connection

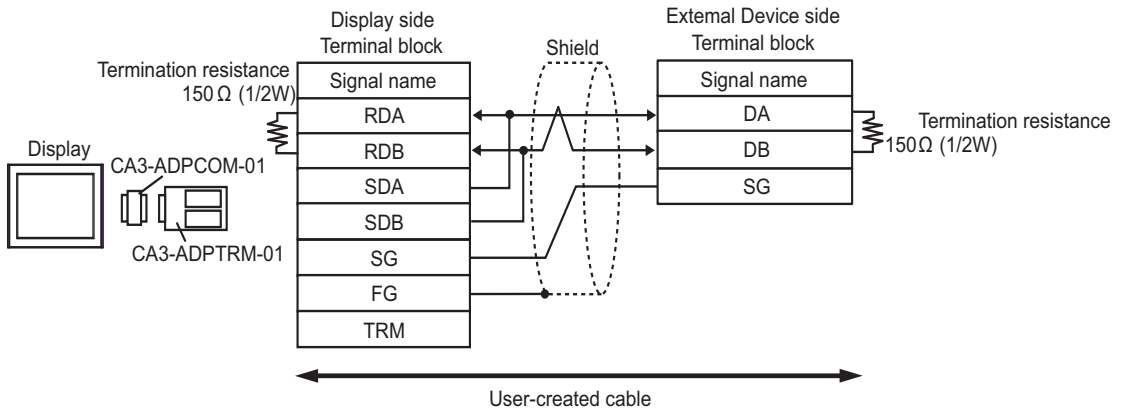

- 1:n Connection

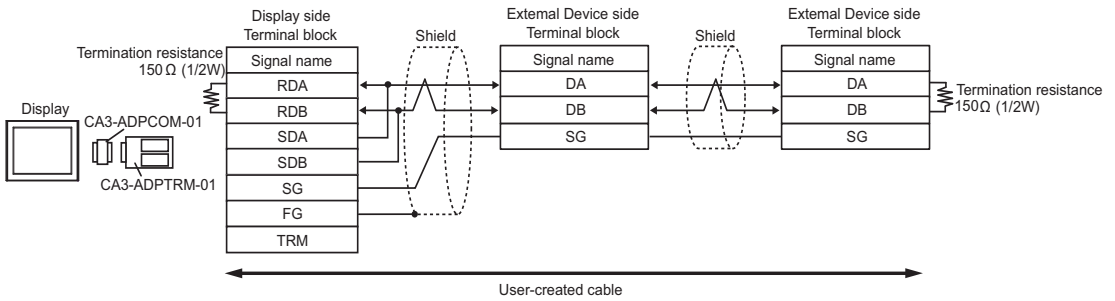



1B)

- 1:1 Connection

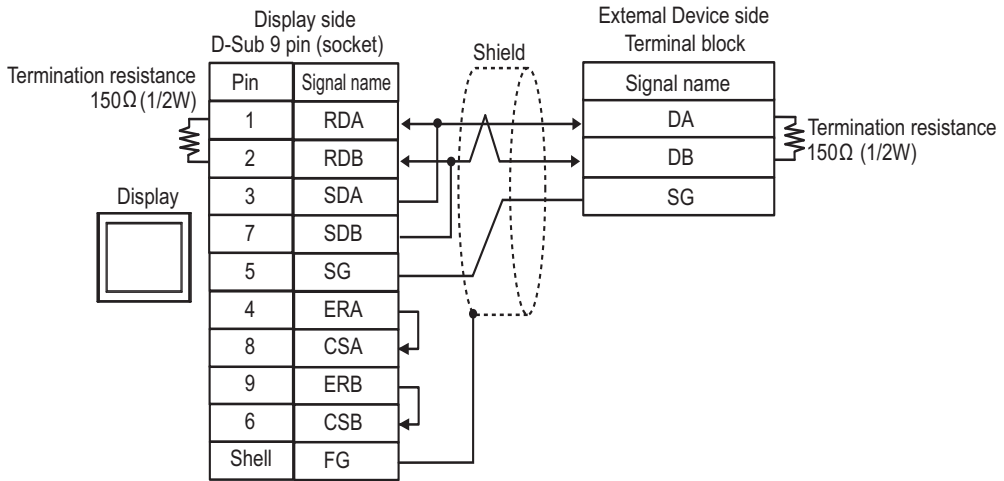

- 1:n Connection

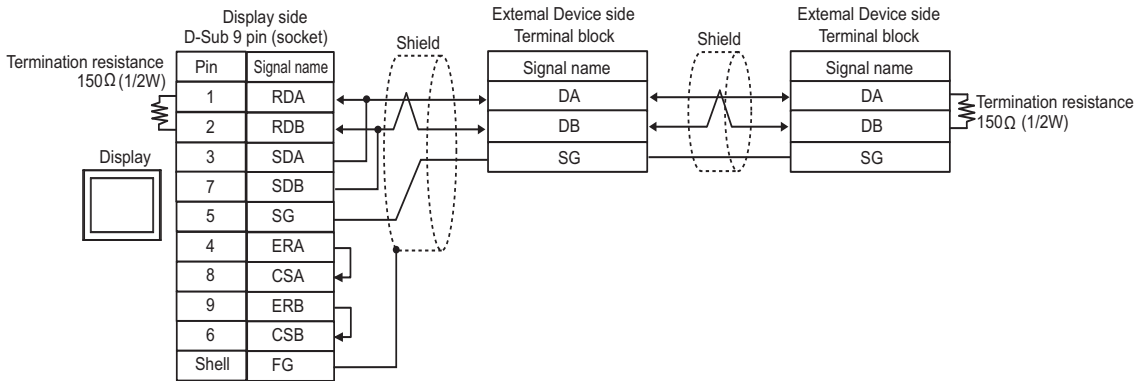

1C)

- 1:1 Connection

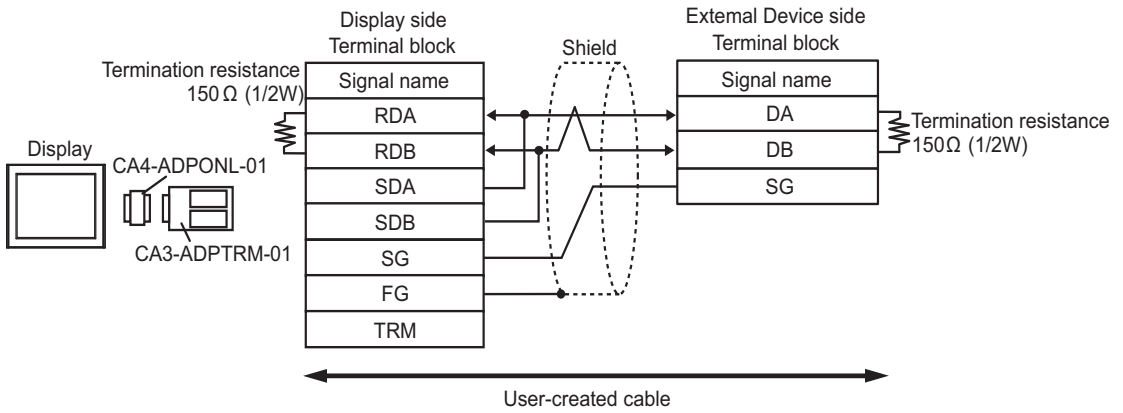

- 1:n Connection

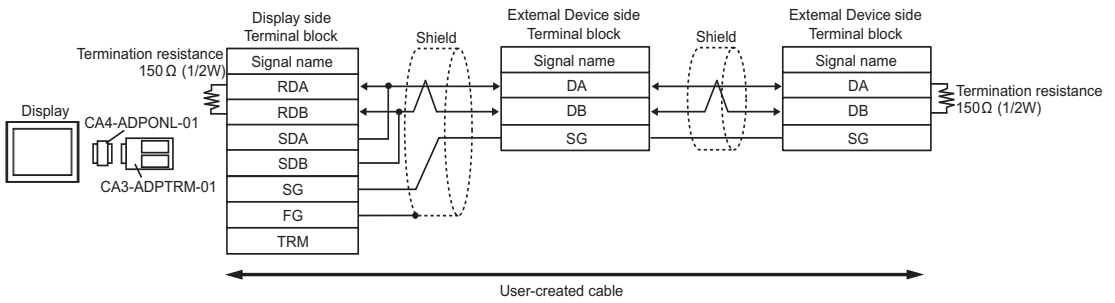

1D)

- 1:1 Connection

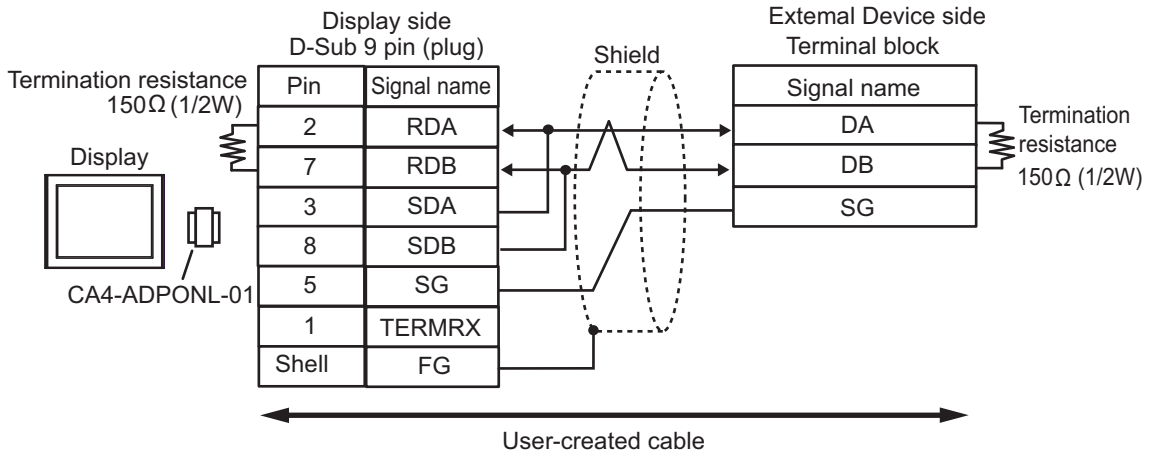

- 1:n Connection

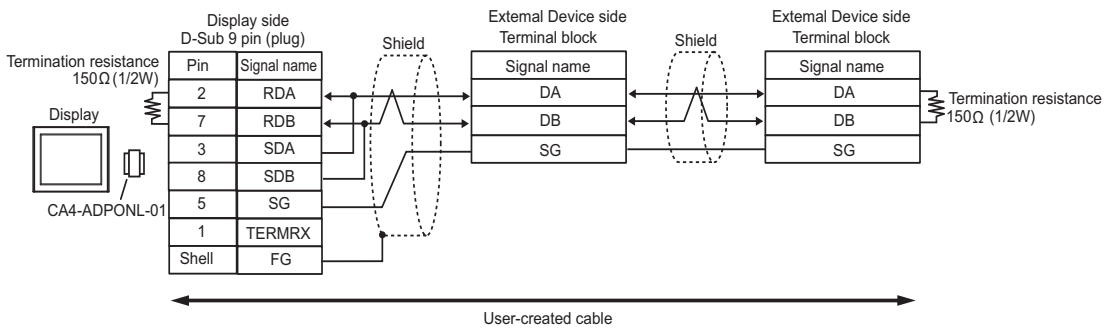

1E)

- 1:1 Connection

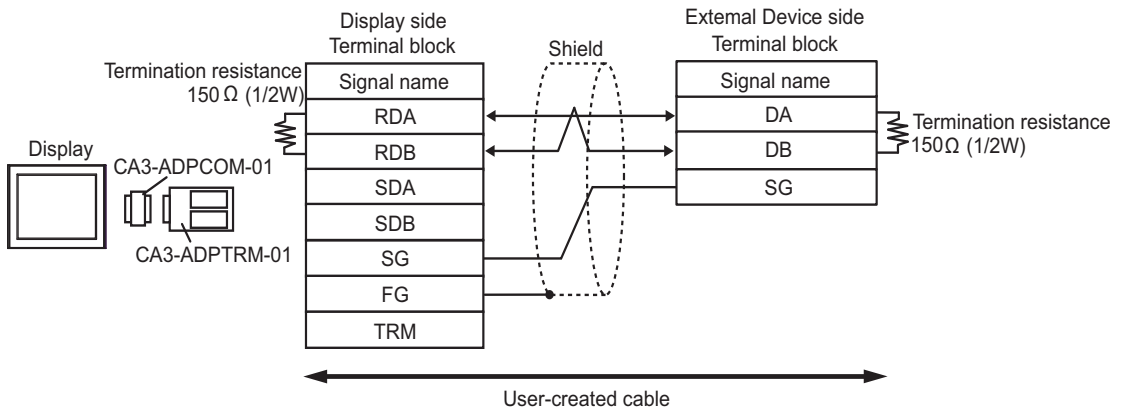

- 1:n Connection

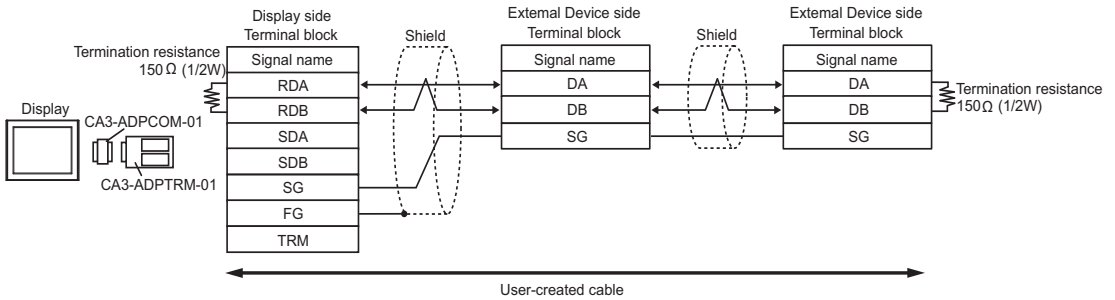

1F)

- 1:1 Connection

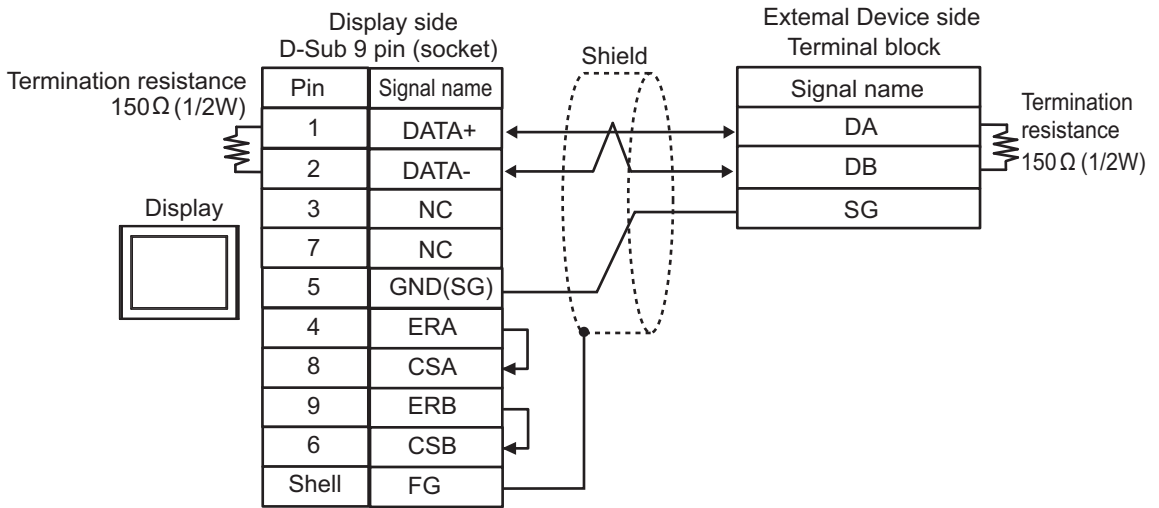

- 1:n Connection

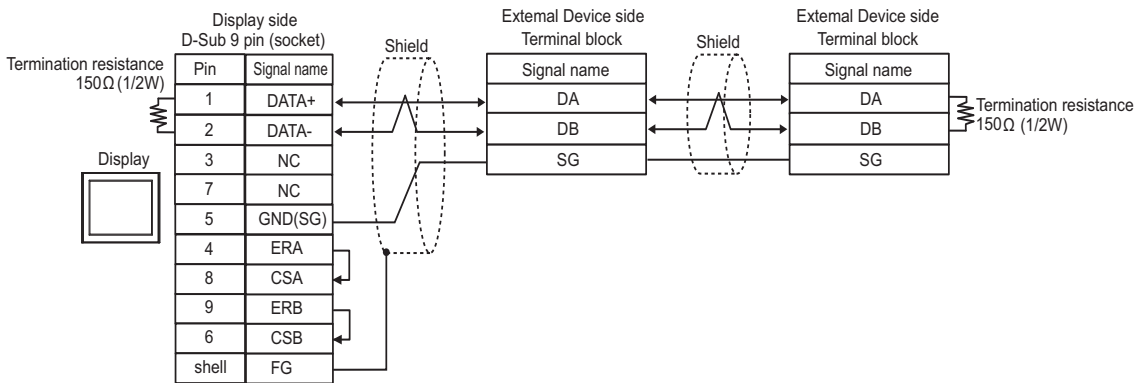

1G)

- 1:1 Connection

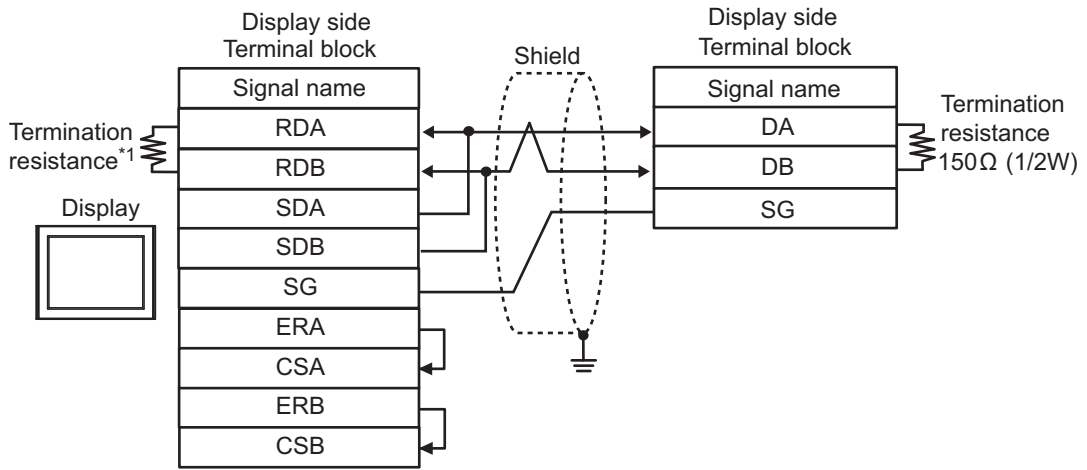

- 1:n Connection

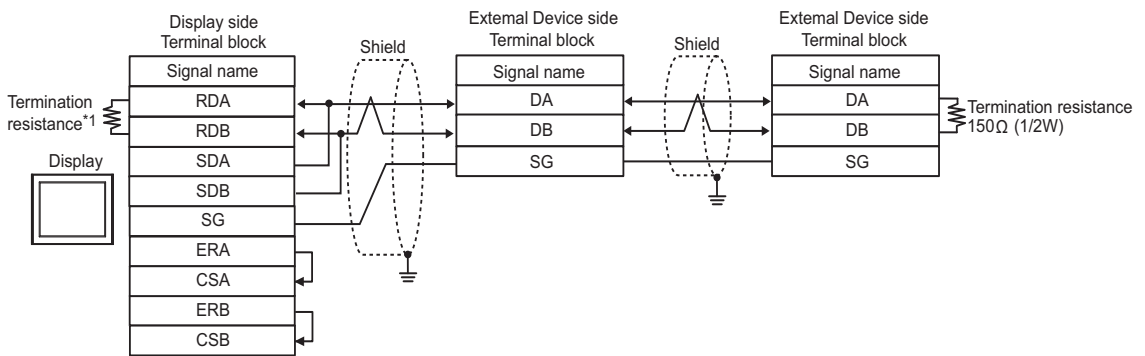

\*1 Use a built-in resistance in the Display as termination resistance. Set the DIP Switch on the rear side of the Display as below.

DIP Switch	Setup Description
1	OFF
2	OFF
3	ON
4	ON

1H)

- 1:1 Connection

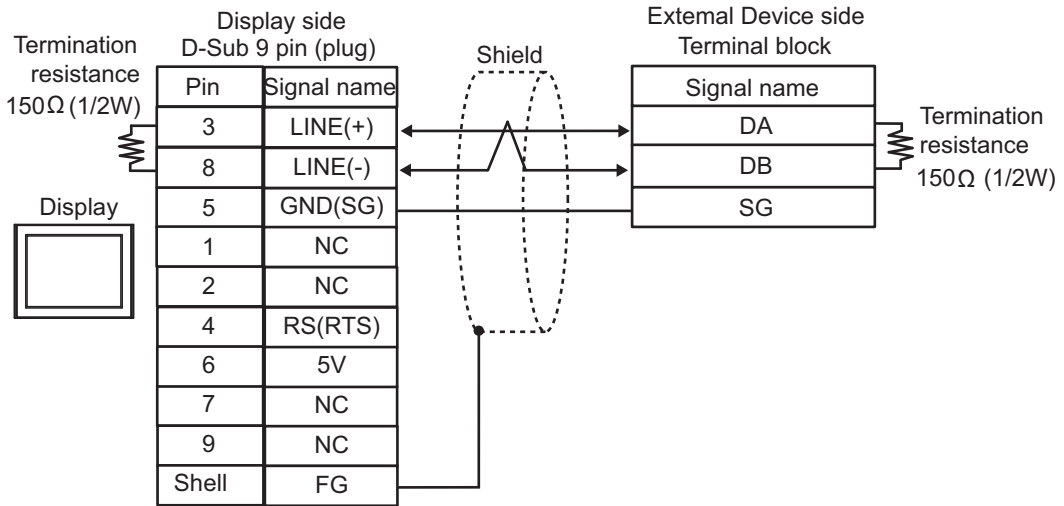

- 1:n Connection

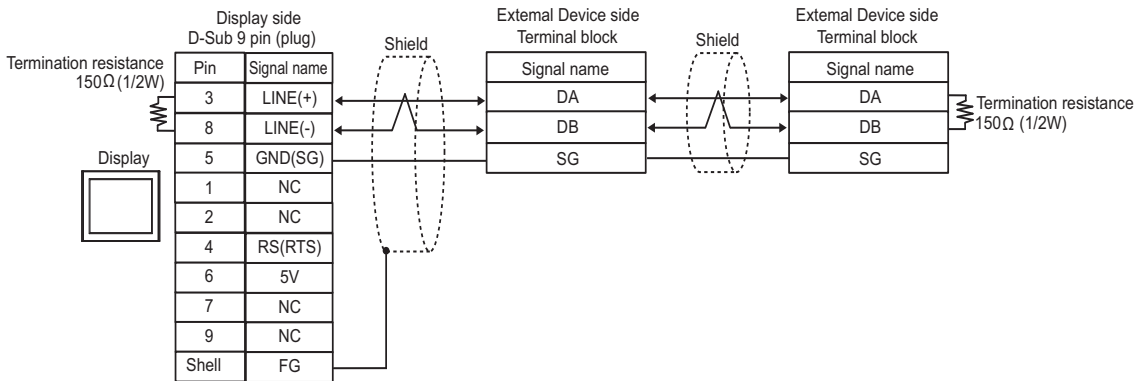

**IMPORTANT**

• The 5V output (Pin #6) on the Display is the power for the Siemens AG's PROFIBUS connector. Do not use it for other devices.

**NOTE**

• In COM on the GP-4107, the SG and FG terminals are isolated.

11)

- 1:1 Connection

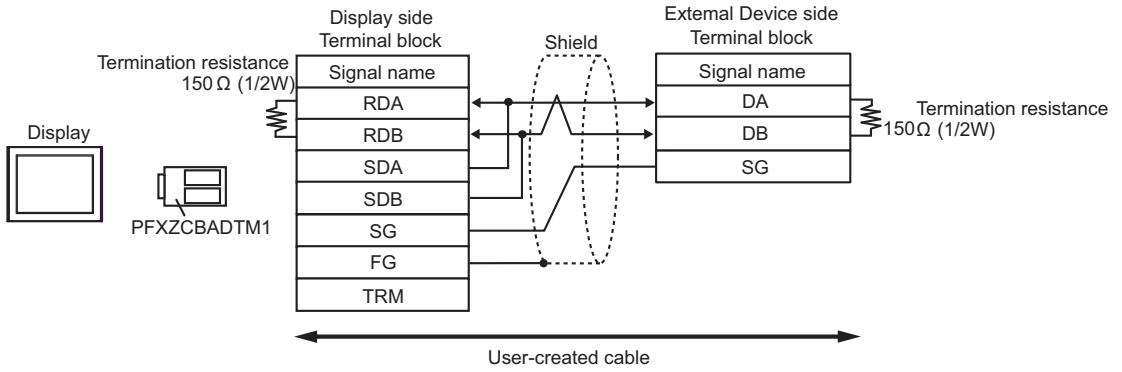

- 1:n Connection

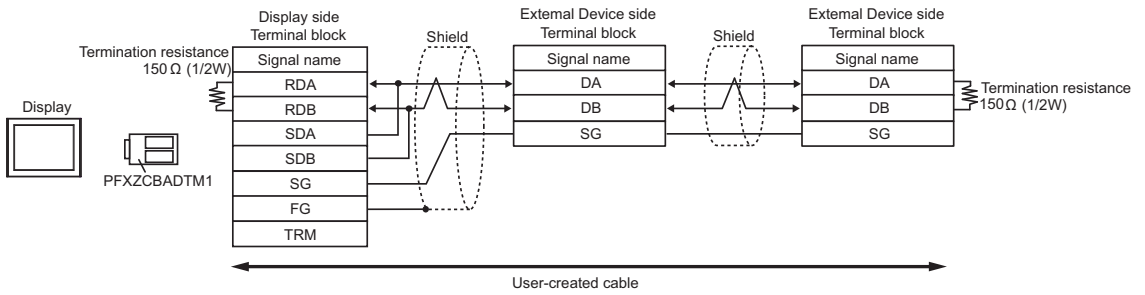



1J)

- 1:1 Connection

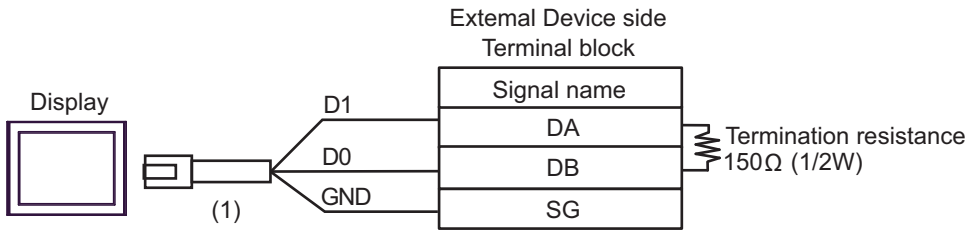

- 1:n Connection

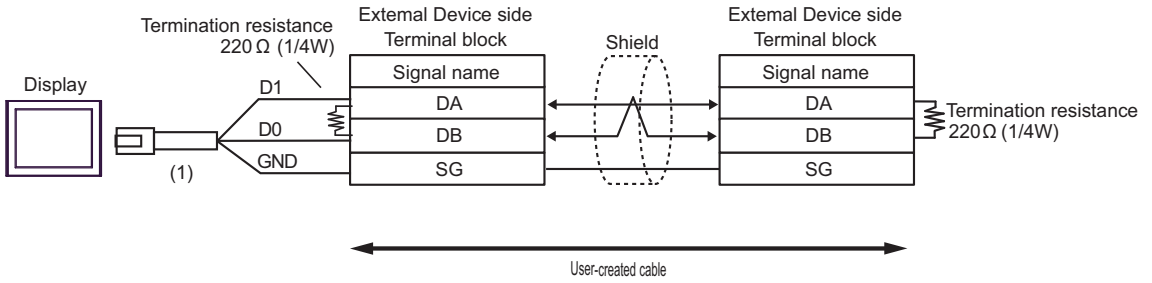

Legend	Name	Notes
(1)	RJ45 RS-485 Cable (5m) by Pro-face PFXZLMCBJR81	

1K)

- 1:1 Connection

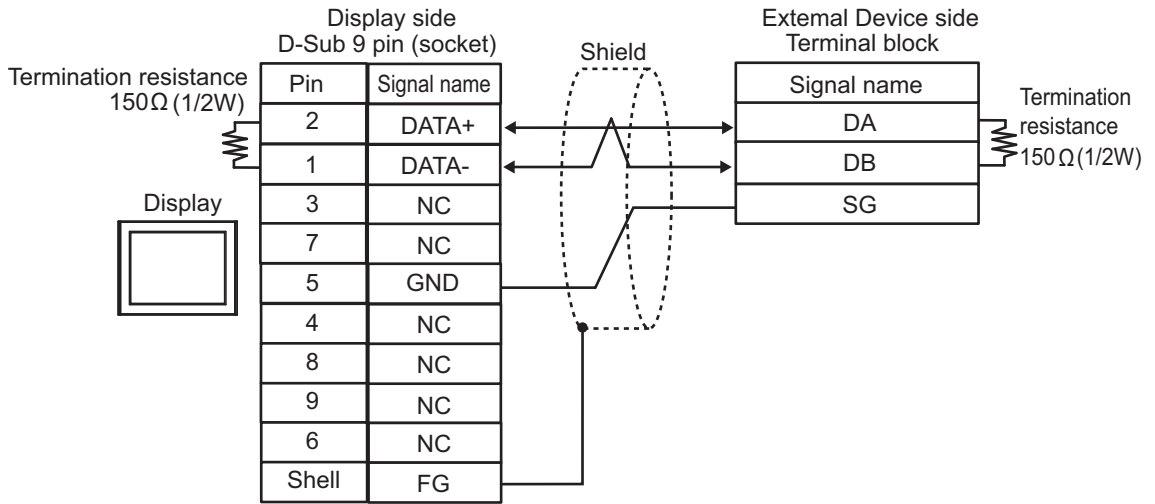

- 1:n Connection

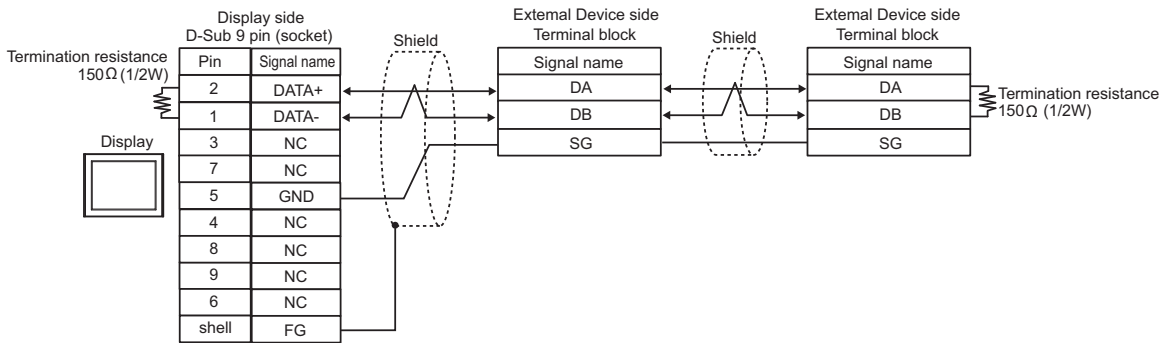

Cable Diagram 2

Display (Connection Port)	Cable		Remarks
GP3000 (COM1) GP4000* <sup>1</sup> (COM1) SP5000* <sup>2</sup> (COM1/2) SP-5B00 (COM1) ST3000 (COM1) ST6000 (COM1) STM6000 (COM1) LT3000 (COM1) IPC* <sup>3</sup> PC/AT	2A	User created cable	Cable length: 15m or less
GP-4105 (COM1) GP-4115T (COM1) GP-4115T3 (COM1)	2B	User created cable	Cable length: 15m or less
LT-4*01TM (COM1) LT-Rear Module (COM1)	2C	RJ45 RS-232C Cable (5m) by Pro-face PFXZLMCBJR21	Cable length: 5m or less

- \*1 All GP4000 models except GP-4100 Series and GP-4203T
- \*2 Except SP-5B00
- \*3 Only a COM port that can communicate with RS-232C can be used.  
 ■ IPC COM Port (page 5)

2A)

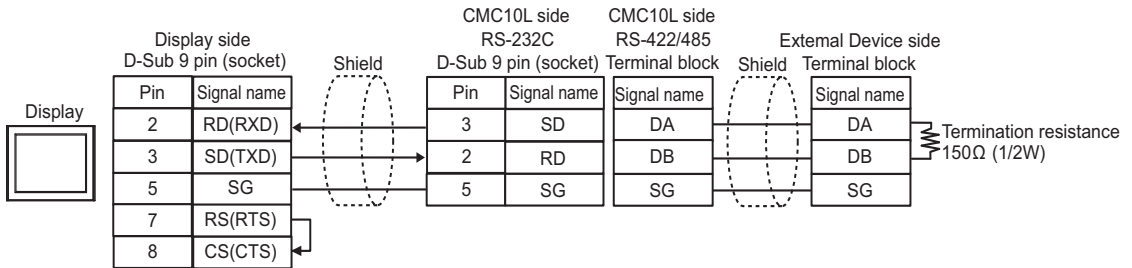

2B)

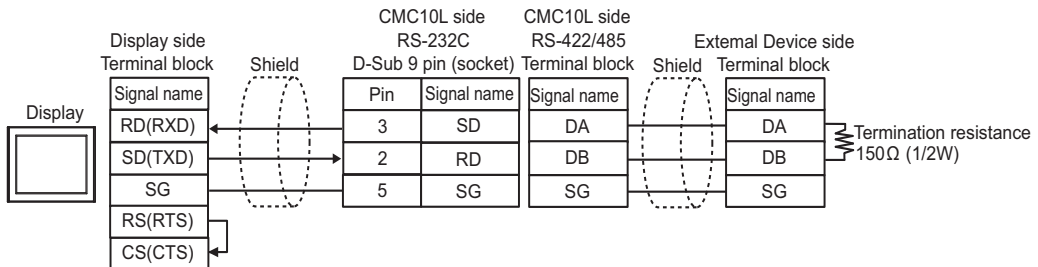

2C)

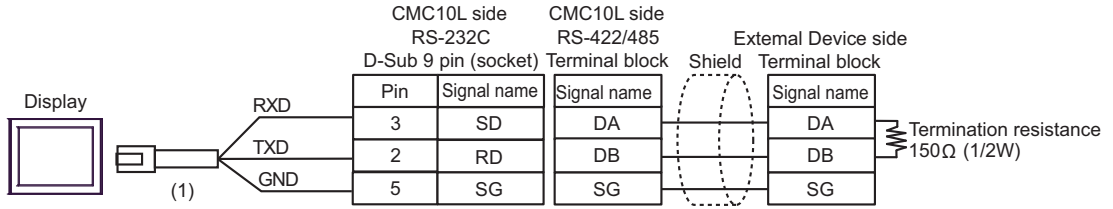

Legend	Name	Notes
(1)	RJ45 RS-232C Cable (5m) by Pro-face PFXZLMCBJR21	

Cable Diagram 3

Display (Connection Port)	Cable		Remarks
GP-4401 (COM2)	3A	RS-422 Terminal Block Conversion Adapter by Pro-face PFXZCBADTM1 + User-created cable	Cable length: 500m or less
	3B	User-created cable	

3A)

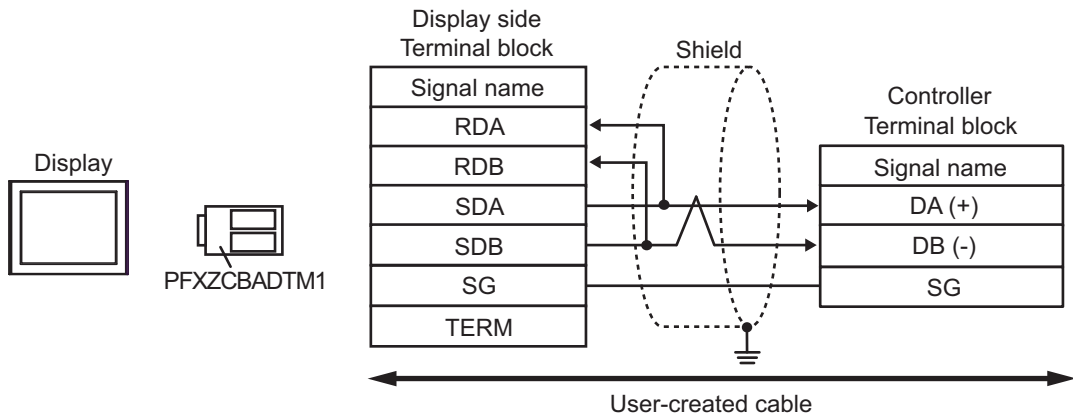

**NOTE**

- No termination resistor is required.

3B)

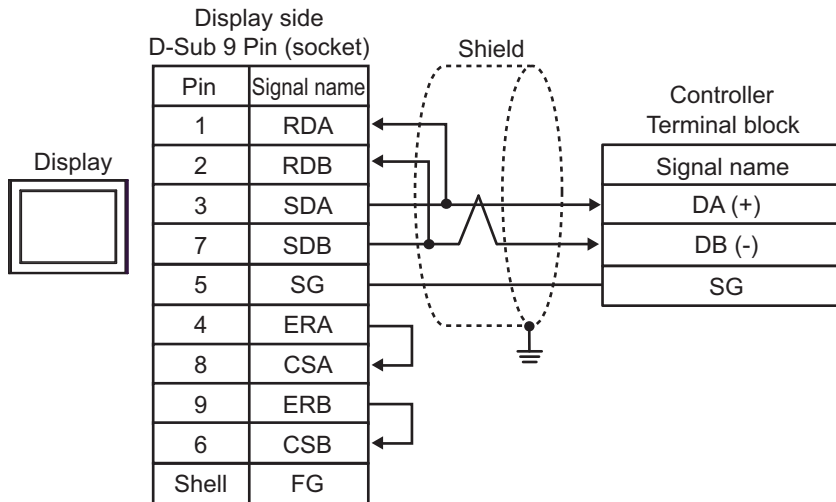

**NOTE**

- No termination resistor is required.

## 6 Supported Devices

The following table shows the range of supported device addresses. Please note that the actual supported range of the devices varies depending on the External Device to be used. Please check the actual range in the manual of your External Device.

Enter the External Device address in the dialog box below.



1

1. Address

Enter the address.

6.1 NX Series

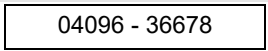
 : This address can be specified as system data area.

Device	Bit Address	Word Address	32 bits	Remarks
Data	04096.00 - 36678.15	 04096 - 36678		*1 *2

- \*1 When you write to the bit address, the Display reads the entire word, sets the defined bit, then returns the new word value to the External Device. If the External Device writes data to this word address during the bit write process, the resulting data may be incorrect.
- \*2 If the address is out of the system area, an error occurs.

---

**NOTE**

- There are read-only addresses. Refer to your External Device manual on precautions when reading and writing to device addresses.
- You can only set the Read Area Size for the system area available to use in the External Device. Please refer to the GP-Pro EX Reference Manual for Read Area Size.

Cf. GP-Pro EX Reference Manual "LS Area (Direct Access Method Area)"

- Refer to the precautions on manual notation for icons in the table.



 "Manual Symbols and Terminology"

- When you use a non-existent address, a read error may not display. In this case, "0" is returned as the read data. Note, however, that write errors are displayed.

---

6.2 K1G Series

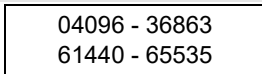
 : This address can be specified as system data area.

Device	Bit Address	Word Address	32 bits	Remarks
Data	04096,00 - 36863,15 61440,00 - 65535,15	 04096 - 36863 61440 - 65535		*1 *2

\*1 When you write to the bit address, the Display reads the entire word, sets the defined bit, then returns the new word value to the External Device. If the External Device writes data to this word address during the bit write process, the resulting data may be incorrect.

\*2 The Display uses the generic Modbus address format. Please refer to the following table for associated address ranges between the External Device and Display.

External Device's Address Types	External Device's Address Ranges	Display's Address Ranges
Monitoring area	0x1000 - 0x1FFF	04096 - 08191
Setting area	0x2000 - 0x2FFF	08192 - 12287
Channel1 area	0x3000 - 0x3FFF	12288 - 16383
Channel2 area	0x4000 - 0x4FFF	16384 - 20479
Channel3 area	0x5000 - 0x5FFF	20480 - 24575
Channel4 area	0x6000 - 0x6FFF	24576 - 28671
Intensity area	0x7000 - 0x7FFF	28672 - 32767
Operation area	0x8000 - 0x8FFF	32768 - 36863
Special Function area	0xF000 - 0xFFFF	61440 - 65535

**NOTE**

- There are read-only addresses. Refer to your External Device manual on precautions when reading and writing to device addresses.
- You can only set the Read Area Size for the system area available to use in the External Device. Please refer to the GP-Pro EX Reference Manual for Read Area Size.

Cf. GP-Pro EX Reference Manual "LS Area (Direct Access Method Area)"

- Refer to the precautions on manual notation for icons in the table.  
 "Manual Symbols and Terminology"
- When you use a non-existent address, a read error may not display. In this case, "0" is returned as the read data. Note, however, that write errors are displayed.



## 6.3 C1M Series

 : This address can be specified as system data area.

Device	Bit Address	Word Address	32 bits	Remarks
Data	00273.0 - 14859.15 16657.0 - 31243.15	00273 - 14859 16657 - 31243		

**NOTE**

- There are read-only addresses. Refer to your External Device manual on precautions when reading and writing to device addresses.
  - You can only set the Read Area Size for the system area available to use in the External Device. Please refer to the GP-Pro EX Reference Manual for Read Area Size.
- Cf. GP-Pro EX Reference Manual "LS Area (Direct Access Method Area)"
- Refer to the precautions on manual notation for icons in the table.
-  "Manual Symbols and Terminology"
- When you use a non-existent address, a read error may not display. In this case, "0" is returned as the read data. Note, however, that write errors are displayed.

## 7 Device Code and Address Code

Use device code and address code when you set "Device Type & Address" for the address type of the data display or other devices.

### 7.1 NX Series

Device	Device Name	Device Code (HEX)	Address Code
Data	-	0000	Word Address

### 7.2 K1G Series

Device	Device Name	Device Code (HEX)	Address Code
Data	-	0000	Word Address

### 7.3 C1M Series

Device	Device Name	Device Code (HEX)	Address Code
Data	-	0000	Word Address

## 8 Error Messages

Error messages are displayed on the screen of the Display as follows: "No.: Device Name: Error Message (Error Occurrence Area)". Each description is shown below.

Item	Description
No.	Error number.
Device Name	Name of the External Device where an error has occurred. Device/PLC name is the title of the External Device set with GP-Pro EX. (Initial value [PLC1])
Error Message	Displays messages related to an error that has occurred.
Error Occurrence Area	<p>Displays the IP address or device address of the External Device where an error has occurred, or error codes received from the External Device.</p> <p><b>NOTE</b></p> <ul style="list-style-type: none"> <li>• IP addresses are displayed as "IP address (Decimal): MAC address (Hex)".</li> <li>• Device addresses are displayed as "Address: Device address".</li> <li>• Received error codes are displayed as "Decimal [Hex]".</li> </ul>

Example of an Error Message

"RHAA035: PLC1: Error has been responded for device write command (Error Code: 2[02H])"

**NOTE**

- Refer to your External Device manual for details on received error codes.
- Refer to "Display-related errors" in "Maintenance/Troubleshooting Guide" for details on the error messages common to the driver.

### ■ Error Codes Unique to External Device

Error Code (HEX)	Description
01	Does not support the corresponding Function Code.
02	The specified data address does not exist.
03	Data value error.

