



Temperature Controller CompoWay/F Driver

1	System Configuration.....	3
2	Selection of External Device	8
3	Example of Communication Setting.....	9
4	Setup Items.....	18
5	Cable Diagram	36
6	Supported device	38
7	Device Code and Address Code.....	60
8	Error Messages.....	78

Introduction

This manual describes how to connect the Display and the External Device (target Temperature Controller).
 In this manual, the connection procedure will be described by following the below sections:

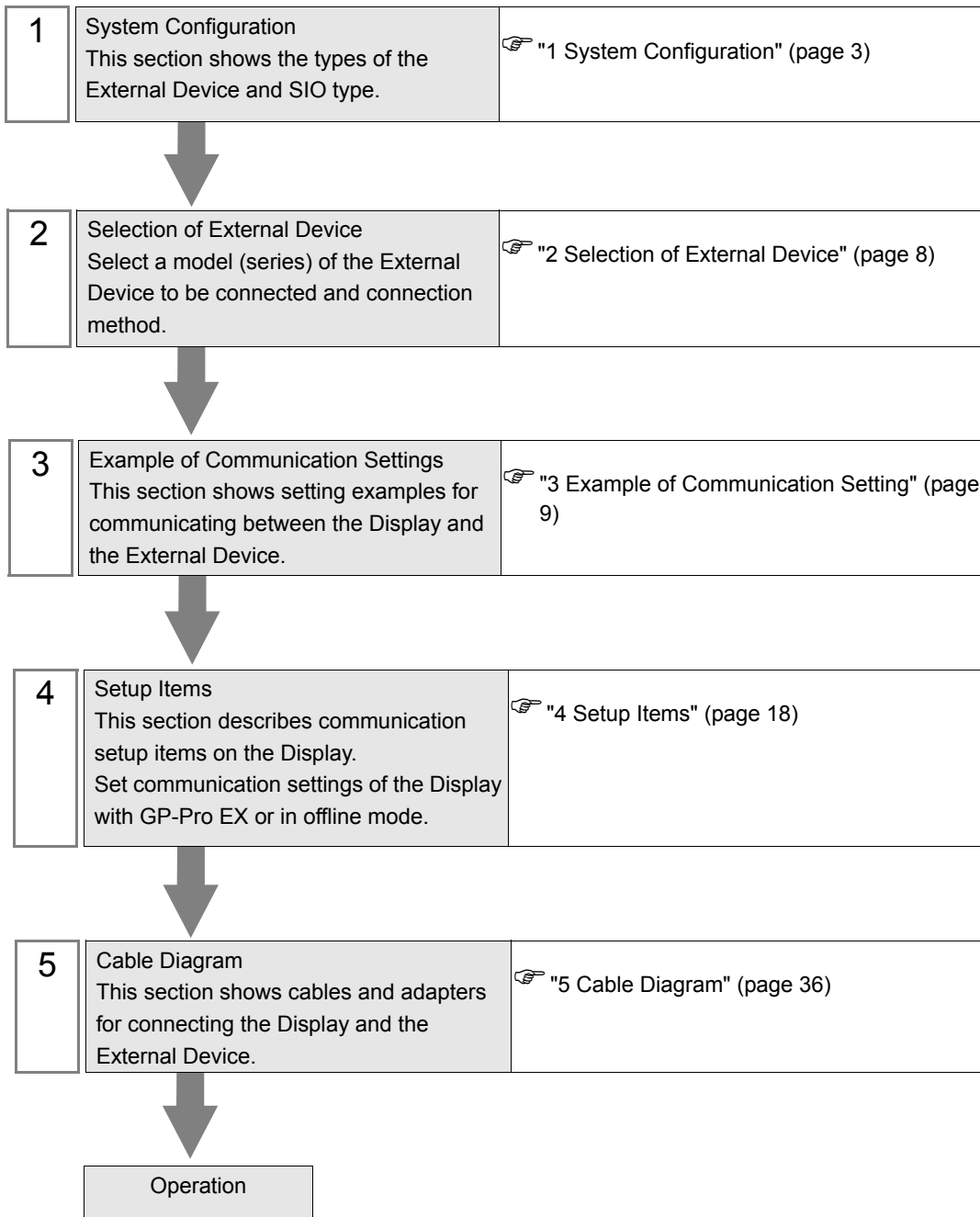

1 System Configuration

The system configuration in the case when the External Device of OMRON Corporation and the Display are connected is shown.

Series	CPU*1	Link I/F	SIO Type	Communication Settings	Cable Diagram
THERMAC NEO	E5EN-□□□□□-FLK E5AN-□□□□□-FLK	Terminal block on the controller	RS232C	Setting Example 1 (page 9)	Cable Diagram 1 (page 37)
	E5CN-H□□□□□□□□-□-FLK E5EN-H□□□□□□□□□-□-FLK E5AN-H□□□□□□□□□-□-FLK			Setting Example 6 (page 19)	Cable Diagram 1 (page 37)
	E5EN-□□□□□-FLK E5AN-□□□□□-FLK E5CN-□□□□□-FLK E5GN-□□□□□-FLK		RS485 (2wire)	Setting Example 2 (page 11)	Cable Diagram 2 (page 39)
	E5CN-H□□□□□□□□-□-FLK E5EN-H□□□□□□□□□-□-FLK E5AN-H□□□□□□□□□-□-FLK			Setting Example 7 (page 21)	Cable Diagram 2 (page 39)
	E5EN-H□□□□□□□□□-□-FLK E5AN-H□□□□□□□□□-□-FLK		RS485 (4wire)	Setting Example 8 (page 23)	Cable Diagram 3 (page 52)
THERMAC R	E5AR-□□□□□□□□□□-FLK E5ER-□□□□□□□□□□-FLK	Terminal block on the controller	RS485 (2wire)	Setting Example 3 (page 13)	Cable Diagram 2 (page 39)
In-Panel NEO	E5ZN-□□□□□□□-FLK	Terminal block on the controller	RS485 (2wire) 1:1	Setting Example 4 (page 15)	Cable Diagram 2 (page 39)
			RS485 (2wire) 1:n	Setting Example 5 (page 17)	Cable Diagram 2 (page 39)
THERMAC	E5CC-□□□□□□□-□□□□ E5EC-□□□□□□□-□□□□ E5AC-□□□□□□□-□□□□ E5DC-□□□□□□□-□□□□ E5GC-□□□□□□□-□□□□	Terminal block on the controller	RS485 (2wire)	Setting Example 9 (page 25)	Cable Diagram 2 (page 39)
	E5CC-T□□□□□□□□-□□□□ E5EC-T□□□□□□□□-□□□□ E5AC-T□□□□□□□□-□□□□			Setting Example 10 (page 27)	Cable Diagram 2 (page 39)
	E5CD-□□□□□□□-□□□□ E5ED-□□□□□□□-□□□□			Setting Example 11 (page 29)	Cable Diagram 2 (page 39)

*1 Model number of the controller "□" varies depending on the function specification of each controller.

■ Connection Configuration

- 1:1 Connections



- 1:n Connection

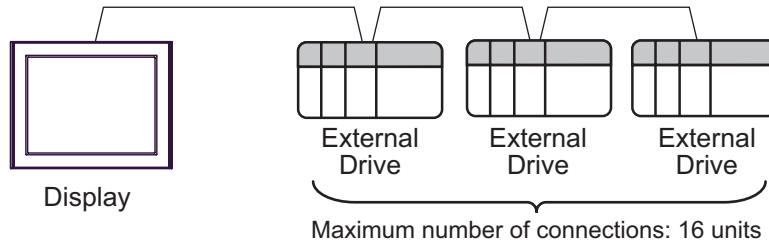

■ IPC COM Port

When connecting IPC with an External Device, the COM port used depends on the series and SIO type. Please refer to the IPC manual for details.

Usable port

Series	Usable Port		
	RS-232C	RS-422/485(4 wire)	RS-422/485(2 wire)
PS-2000B	COM1 ^{*1} , COM2, COM3 ^{*1} , COM4	-	-
PS-3450A, PS-3451A, PS3000-BA, PS3001-BD	COM1, COM2 ^{*1*2}	COM2 ^{*1*2}	COM2 ^{*1*2}
PS-3650A (T41 model), PS-3651A (T41 model)	COM1 ^{*1}	-	-
PS-3650A (T42 model), PS-3651A (T42 model)	COM1 ^{*1*2} , COM2	COM1 ^{*1*2}	COM1 ^{*1*2}
PS-3700A (Pentium®4-M) PS-3710A	COM1 ^{*1} , COM2 ^{*1} , COM3 ^{*2} , COM4	COM3 ^{*2}	COM3 ^{*2}
PS-3711A	COM1 ^{*1} , COM2 ^{*2}	COM2 ^{*2}	COM2 ^{*2}
PS4000 ^{*3}	COM1, COM2	-	-
PL3000	COM1 ^{*1*2} , COM2 ^{*1} , COM3, COM4	COM1 ^{*1*2}	COM1 ^{*1*2}
PE-4000B Atom N270	COM1, COM2	-	-
PE-4000B Atom N2600	COM1, COM2	COM3 ^{*4} , COM4 ^{*4} , COM5 ^{*4} , COM6 ^{*4}	COM3 ^{*4} , COM4 ^{*4} , COM5 ^{*4} , COM6 ^{*4}
PS5000 (Slim Panel Type Core i3 Model) ^{*5*6}	COM1, COM2 ^{*4}	COM2 ^{*4}	COM2 ^{*4}
PS5000 (Slim Panel Type Atom Model) ^{*5*6}	COM1, COM2 ^{*7}	COM2 ^{*7}	COM2 ^{*7}
PS5000 (Enclosed Panel Type) ^{*8}	COM1	-	-
PS5000 (Modular Type PFXPU/PFXPP) ^{*5*6} PS5000 (Modular Type PFXPL2B5-6)	COM1 ^{*7}	COM1 ^{*7}	COM1 ^{*7}
PS5000 (Modular Type PFXPL2B1-4)	COM1, COM2 ^{*7}	COM2 ^{*7}	COM2 ^{*7}

*1 The RI/5V can be switched. Use the IPC's switch to change if necessary.

*2 Set up the SIO type with the DIP Switch. Please set up as follows according to SIO type to be used.

*3 When making communication between an External Device and COM port on the Expansion slot, only RS-232C is supported. However, ER (DTR/CTS) control cannot be executed because of the specification of COM port.

For connection with External Device, use user-created cables and disable Pin Nos. 1, 4, 6 and 9. Please refer to the IPC manual for details of pin layout.

*4 Set up the SIO type with the BIOS. Please refer to the IPC manual for details of BIOS.

- *5 When setting up communication between an External Device and the RS-232C/422/485 interface module, use the IPC (RS-232C) or PS5000 (RS-422/485) cable diagrams. However, when using PFXZPBMPR42P2 in a RS-422/485 (4-wire) configuration with no flow control, connect 7.RTS+ and 8.CTS+, and connect 6.RTS- and 9.CTS-.
When using RS-422/485 communication with External Devices, you may need to reduce the transmission speed and increase the TX Wait time.
- *6 To use RS-422/485 communication on the RS-232C/422/485 interface module, the DIP Switch setting is required. Please refer to "Knowledge Base" (FAQs) on the support site. (<http://www.pro-face.com/trans/en/manual/1001.html>)

Settings	FAQ ID
PFXZPBMPR42P2, RS422/485 change method	FA263858
PFXZPBMPR42P2 termination resistor setting	FA263974
PFXZPBMPR44P2, RS422/485 change method	FA264087
PFXZPBMPR44P2 termination resistor setting	FA264088

- *7 Set up the SIO type with the DIP Switch. Please refer to the IPC manual for details of DIP Switch. The BOX Atom has not a switch to set the RS-232C, RS-422/485 mode. Use the BIOS for the setting.
- *8 For the connection with the External Device, on the user-created cable read as if the connector on the Display-side is a M12 A-coding 8 pin socket. The pin assignment is the same as described in the cable diagram. For the M12 A-coding connector, use PFXZPSCNM122.

DIP Switch settings (PL3000 / PS3000 Series)

RS-232C

DIP Switch	Setting	Description
1	OFF*1	Reserved (always OFF)
2	OFF	SIO type: RS-232C
3	OFF	
4	OFF	Output mode of SD (TXD) data: Always output
5	OFF	Terminal resistance (220Ω) insertion to SD (TXD): None
6	OFF	Terminal resistance (220Ω) insertion to RD (RXD): None
7	OFF	Short-circuit of SDA (TXA) and RDA (RXA): Not available
8	OFF	Short-circuit of SDB (TXB) and RDB (RXB): Not available
9	OFF	RS (RTS) Auto control mode: Disabled
10	OFF	

*1 When using PS-3450A, PS-3451A, PS3000-BA and PS3001-BD, turn ON the set value.

RS-422/485 (4 wire)

DIP Switch	Setting	Description
1	OFF	Reserved (always OFF)
2	ON	SIO type: RS-422/485
3	ON	
4	OFF	Output mode of SD (TXD) data: Always output
5	OFF	Terminal resistance (220Ω) insertion to SD (TXD): None
6	OFF	Terminal resistance (220Ω) insertion to RD (RXD): None
7	OFF	Short-circuit of SDA (TXA) and RDA (RXA): Not available
8	OFF	Short-circuit of SDB (TXB) and RDB (RXB): Not available
9	OFF	RS (RTS) Auto control mode: Disabled
10	OFF	

RS-422/485 (2 wire)

DIP Switch	Setting	Description
1	OFF	Reserved (always OFF)
2	ON	SIO type: RS-422/485
3	ON	
4	OFF	Output mode of SD (TXD) data: Always output
5	OFF	Terminal resistance (220Ω) insertion to SD (TXD): None
6	OFF	Terminal resistance (220Ω) insertion to RD (RXD): None
7	ON	Short-circuit of SDA (TXA) and RDA (RXA): Available
8	ON	Short-circuit of SDB (TXB) and RDB (RXB): Available
9	ON	RS (RTS) Auto control mode: Enabled
10	ON	

2 Selection of External Device

Select the External Device to be connected to the Display.

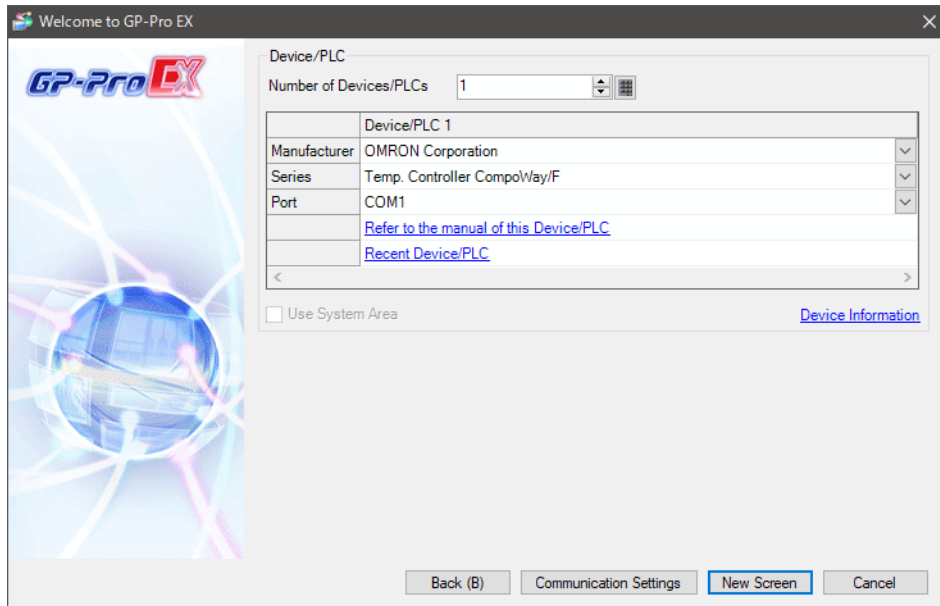

Setup Items	Setup Description
Number of Devices/PLCs	Enter an integer from 1 to 4 to define the number of Devices/PLCs to connect to the display.
Manufacturer	Select the manufacturer of the External Device to connect. Select "OMRON Corporation".
Series	Select the External Device model (series) and the connection method. Select "Temp. Controller CompoWay/F". In System configuration, make sure the External Device you are connecting is supported by "Temp. Controller CompoWay/F". ☞ "1 System Configuration" (page 3)
Port	Select the Display port to connect to the External Device.
Use System Area	Cannot be set in this driver.

3 Example of Communication Setting

Examples of communication settings of the Display and the External Device, recommended by Digital Electronics Corp., are shown.

3.1 Setting Example 1

■ Setting of GP-Pro EX

◆ Communication Settings

To display the setup screen, from the [Project] menu, point to [System Settings] and select [Device/PLC].

◆ Device Setting

To display the [Individual Device Settings] dialog box, from [Device-Specific Settings] in the [Device/PLC] window, select the external device and click [Settings] .

To connect multiple External Devices, from [Device-Specific Settings] in the [Device/PLC] window, click [Add Device] to add another External Device.

NOTE • Set the HOST link unit No. for "Unit No."

■ Settings of External Device

Use the level key, mode key, down key and up key in front of the Temperature Controller for communication settings of the External Device.

Please refer to the manual of the Temperature Controller for more details.

◆ Procedure

1. Press and hold the level key (3 minutes or more) to transfer from the operation level to the default level.
2. Press the level key again to transfer from the default level to the communication setting level.
3. Press the mode key to select the parameter.
4. Press the down/up keys to change the setting.
5. Press and hold the level key to transfer to the operation level.

◆ Setting Value

PSEL	CWF
U-NO	1
BPS	9.6
LEN	7
SBIT	2
PRTY	EVEN
SDWT	2

NOTE

- Parameters to be set vary depending on the Temperature Controller. Please refer to the manual of the Temperature Controller for more details.
- Set Wait to Send to 2ms or more. Adjust Wait to Send according to the communication status.

3.2 Setting Example 2

■ Setting of GP-Pro EX

◆ Communication Settings

To display the setup screen, from the [Project] menu, point to [System Settings] and select [Device/PLC].

◆ Device Setting

To display the [Individual Device Settings] dialog box, from [Device-Specific Settings] in the [Device/PLC] window, select the external device and click [Settings] .

To connect multiple External Devices, from [Device-Specific Settings] in the [Device/PLC] window, click [Add Device] to add another External Device.

NOTE • Set the HOST link unit No. for "Unit No.".

■ Settings of External Device

Use the level key, mode key, down key and up key in front of the Temperature Controller for communication settings of the External Device.

Please refer to the manual of the Temperature Controller for more details.

◆ Procedure

1. Press and hold the level key (3 minutes or more) to transfer from the operation level to the default level.
2. Press the level key again to transfer from the default level to the communication setting level.
3. Press the mode key to select the parameter.
4. Press the down/up keys to change the setting.
5. Press and hold the level key to transfer to the operation level.

◆ Setting Value

PSEL	CWF
U-NO	1
BPS	9.6
LEN	7
SBIT	2
PRTY	EVEN
SDWT	2

NOTE

- Parameters to be set vary depending on the Temperature Controller. Please refer to the manual of the Temperature Controller for more details.
- Set Wait to Send to 2ms or more. Adjust Wait to Send according to the communication status.

3.3 Setting Example 3

■ Setting of GP-Pro EX

◆ Communication Settings

To display the setup screen, from the [Project] menu, point to [System Settings] and select [Device/PLC].

Device/PLC 1

Summary [Change Device/PLC](#)

Manufacturer Series Port

Text Data Mode [Change](#)

Communication Settings

SIO Type RS232C RS422/485(2wire) RS422/485(4wire)

Speed

Data Length 7 8

Parity NONE EVEN ODD

Stop Bit 1 2

Flow Control NONE ER(DTR/CTS) XON/XOFF

Timeout (sec)

Retry

Wait To Send (ms)

RI / VCC RI VCC
In the case of RS232C, you can select the 9th pin to RI (Input) or VCC (5V Power Supply). If you use the Digital's RS232C Isolation Unit, please select it to VCC.

Device-Specific Settings

Allowable Number of Devices/PLCs [Add Device](#)

No.	Device Name	Settings
<input type="text" value="1"/>	<input type="text" value="PLC1"/>	<input type="text" value="Series=E5A/ER,Unit No.=1"/>

◆ Device Setting

To display the [Individual Device Settings] dialog box, from [Device-Specific Settings] in the [Device/PLC] window, select the external device and click [Settings] .

To connect multiple External Devices, from [Device-Specific Settings] in the [Device/PLC] window, click [Add Device] to add another External Device.

Individual Device Settings

PLC1

Series

Unit No.

NOTE • Set the HOST link unit No. for "Unit No.".

■ Settings of External Device

Use the level key, mode key, down key and up key in front of the Temperature Controller for communication settings of the External Device.

Please refer to the manual of the Temperature Controller for more details.

◆ Procedure

1. Press and hold the level key (3 minutes or more) to transfer from the operation level to the default level.
2. Press the level key again to transfer from the default level to the communication setting level.
3. Press the mode key to select the parameter.
4. Press the down/up keys to change the setting.
5. Press and hold the level key to transfer to the operation level.

◆ Setting Value

PSEL	CWF
U-NO	1
BPS	9.6
LEN	7
SBIT	2
PRTY	EVEN
SDWT	5

NOTE

- Parameters to be set vary depending on the Temperature Controller. Please refer to the manual of the Temperature Controller for more details.
- Set Wait to Send to 5ms or more. Finely adjust Wait to Send according to the communication status.

3.4 Setting Example 4

■ Setting of GP-Pro EX

◆ Communication Settings

To display the setup screen, from the [Project] menu, point to [System Settings] and select [Device/PLC].

◆ Device Setting

To display the [Individual Device Settings] dialog box, from [Device-Specific Settings] in the [Device/PLC] window, select the external device and click [Settings] .

To connect multiple External Devices, from [Device-Specific Settings] in the [Device/PLC] window, click [Add Device] to add another External Device.

NOTE • Set the HOST link unit No. for "Unit No.".

■ Settings of External Device

Use the level key, mode key, down key and up key in front of the Temperature Controller for communication settings of the External Device.

Please refer to the manual of the Temperature Controller for more details.

◆ Procedure

1. Use the rotary switch in front of the Temperature Controller to set Unit No. (UNIT) and Speed (BPS).
2. Press and hold the level key (3 minutes or more) in front of the Display to transfer from the operation level to the default level.
3. Press the level key several times to transfer from the default level to the communication setting level.
4. Press the mode key to select the parameter.
5. Press the down/up keys to change the setting.
6. Press and hold the level key to transfer to the operation level.

◆ Setting Value

- Setting of the rotary switch of the Temperature Controller

UNIT	1
BPS	1

- Setting of the display exclusive for the Temperature Controller

LEN	7
SBIT	2
PRTY	EVEN
SDWT	5

NOTE

- Parameters to be set vary depending on the Temperature Controller. Please refer to the manual of the Temperature Controller for more details.
- Set Wait to Send to 5ms or more. Finely adjust Wait to Send according to the communication status.

3.5 Setting Example 5

■ Setting of GP-Pro EX

◆ Communication Settings

To display the setup screen, from the [Project] menu, point to [System Settings] and select [Device/PLC].

◆ Device Setting

To display the [Individual Device Settings] dialog box, from [Device-Specific Settings] in the [Device/PLC] window, select the external device and click [Settings] .

To connect multiple External Devices, from [Device-Specific Settings] in the [Device/PLC] window, click [Add Device] to add another External Device.

NOTE • Set the HOST link unit No. for "Unit No.".

■ Settings of External Device

Use the level key, mode key, down key and up key in front of the Temperature Controller for communication settings of the External Device.

Please refer to the manual of the Temperature Controller for more details.

◆ Procedure

1. Use the rotary switch in front of the Temperature Controller to set Unit No. (UNIT) and Speed (BPS).
2. Press and hold the level key (3 minutes or more) in front of the Display to transfer from the operation level to the default level.
3. Press the level key several times to transfer from the default level to the communication setting level.
4. Press the mode key to select the parameter.
5. Press the down/up keys to change the setting.
6. Press and hold the level key to transfer to the operation level.

◆ Setting Value

- Setting of the rotary switch of the Temperature Controller

UNIT	1
BPS	1

- Setting of the display exclusive for the Temperature Controller

LEN	7
SBIT	2
PRTY	EVEN
SDWT	20

NOTE

- Parameters to be set vary depending on the Temperature Controller. Please refer to the manual of the Temperature Controller for more details.
- Set Wait to Send to 20ms or more. Finely adjust Wait to Send according to the communication status.

3.6 Setting Example 6

■ Setting of GP-Pro EX

◆ Communication Settings

To display the setup screen, from the [Project] menu, point to [System Settings] and select [Device/PLC].

The screenshot shows the 'Device/PLC 1' configuration window. It is divided into several sections:

- Summary:** Manufacturer: OMRON Corporation, Series: Temp. Controller CompoWay/F, Port: COM1. Text Data Mode: 1. A 'Change Device/PLC' link is visible.
- Communication Settings:**
 - SIO Type: RS422/485(2wire), RS232C, RS422/485(4wire)
 - Speed: 9600
 - Data Length: 7, 8
 - Parity: EVEN, NONE, ODD
 - Stop Bit: 2, 1
 - Flow Control: NONE, ER(DTR/CTS), XON/XOFF
 - Timeout: 3 (sec)
 - Retry: 2
 - Wait To Send: 2 (ms)
- RI / VCC:** RI, VCC. A note explains the selection criteria for RS232C. A 'Default' button is present.
- Device-Specific Settings:** Allowable Number of Devices/PLCs: 16. An 'Add Device' link is shown.
- Table:**

No.	Device Name	Settings
1	PLC1	Series=E5C/A/EN-H, Unit No.=1

◆ Device Setting

To display the [Individual Device Settings] dialog box, from [Device-Specific Settings] in the [Device/PLC] window, select the external device and click [Settings] .

To connect multiple External Devices, from [Device-Specific Settings] in the [Device/PLC] window, click [Add Device] to add another External Device.

The 'Individual Device Settings' dialog box for 'PLC1' is shown. It contains the following fields and buttons:

- Series: E5C/A/EN-H (dropdown menu)
- Unit No.: 1 (spin box)
- Default button
- OK (O) button
- Cancel button

NOTE • Set the HOST link unit No. for "Unit No.".

■ Settings of External Device

Use the level key, mode key, down key and up key in front of the Temperature Controller for communication settings of the External Device.

Please refer to the manual of the Temperature Controller for more details.

◆ Procedure

1. Press and hold the level key (3 minutes or more) to transfer from the operation level to the default level.
2. Press the level key several times to transfer from the default level to the communication setting level.
3. Press the mode key to select the parameter.
4. Press the down/up keys to change the setting.
5. Press and hold the level key to transfer to the operation level.

◆ Setting Value

PSEL	CWF
U-NO	1
BPS	9.6
LEN	7
SBIT	2
PRTY	EVEN
SDWT	2

NOTE

- Parameters to be set vary depending on the Temperature Controller. Please refer to the manual of the Temperature Controller for more details.
- Set Wait to Send to 2ms or more. Finely adjust Wait to Send according to the communication status.

3.7 Setting Example 7

■ Setting of GP-Pro EX

◆ Communication Settings

To display the setup screen, from the [Project] menu, point to [System Settings] and select [Device/PLC].

The screenshot shows the 'Device/PLC 1' configuration window. It is divided into several sections:

- Summary:** Manufacturer: OMRON Corporation, Series: Temp. Controller CompoWay/F, Port: COM1. Text Data Mode: 1. A 'Change Device/PLC' link is visible.
- Communication Settings:**
 - SIO Type: RS422/485(2wire), RS232C, RS422/485(4wire)
 - Speed: 9600
 - Data Length: 7, 8
 - Parity: EVEN, NONE, ODD
 - Stop Bit: 2, 1
 - Flow Control: NONE, ER(DTR/CTS), XON/XOFF
 - Timeout: 3 (sec)
 - Retry: 2
 - Wait To Send: 2 (ms)
- RI / VCC:** RI, VCC. A note explains that for RS232C, RI is the 9th pin and VCC is the 5V Power Supply. A 'Default' button is present.
- Device-Specific Settings:** Allowable Number of Devices/PLCs: 16. An 'Add Device' link is shown.
- Table:** A table with columns 'No.', 'Device Name', and 'Settings'. It contains one entry: No. 1, Device Name PLC1, Settings Series=E5C/A/EN-H, Unit No.=1. An 'Add Indirect Device' button is on the right.

◆ Device Setting

To display the [Individual Device Settings] dialog box, from [Device-Specific Settings] in the [Device/PLC] window, select the external device and click [Settings] .

To connect multiple External Devices, from [Device-Specific Settings] in the [Device/PLC] window, click [Add Device] to add another External Device.

The screenshot shows the 'Individual Device Settings' dialog box for PLC1. It contains the following fields and buttons:

- Series: E5C/A/EN-H (dropdown menu)
- Unit No.: 1 (spin box)
- Default button
- OK (O) button
- Cancel button

NOTE • Set the HOST link unit No. for "Unit No.".

■ Settings of External Device

Use the level key, mode key, down key and up key in front of the Temperature Controller for communication settings of the External Device.

Please refer to the manual of the Temperature Controller for more details.

◆ Procedure

1. Press and hold the level key (3 minutes or more) to transfer from the operation level to the default level.
2. Press the level key several times to transfer from the default level to the communication setting level.
3. Press the mode key to select the parameter.
4. Press the down/up keys to change the setting.
5. Press and hold the level key to transfer to the operation level.

◆ Setting Value

PSEL	CWF
U-NO	1
BPS	9.6
LEN	7
SBIT	2
PRTY	EVEN
SDWT	2

NOTE

- Parameters to be set vary depending on the Temperature Controller. Please refer to the manual of the Temperature Controller for more details.
- Set Wait to Send to 2ms or more. Finely adjust Wait to Send according to the communication status.

3.8 Setting Example 8

■ Setting of GP-Pro EX

◆ Communication Settings

To display the setup screen, from the [Project] menu, point to [System Settings] and select [Device/PLC].

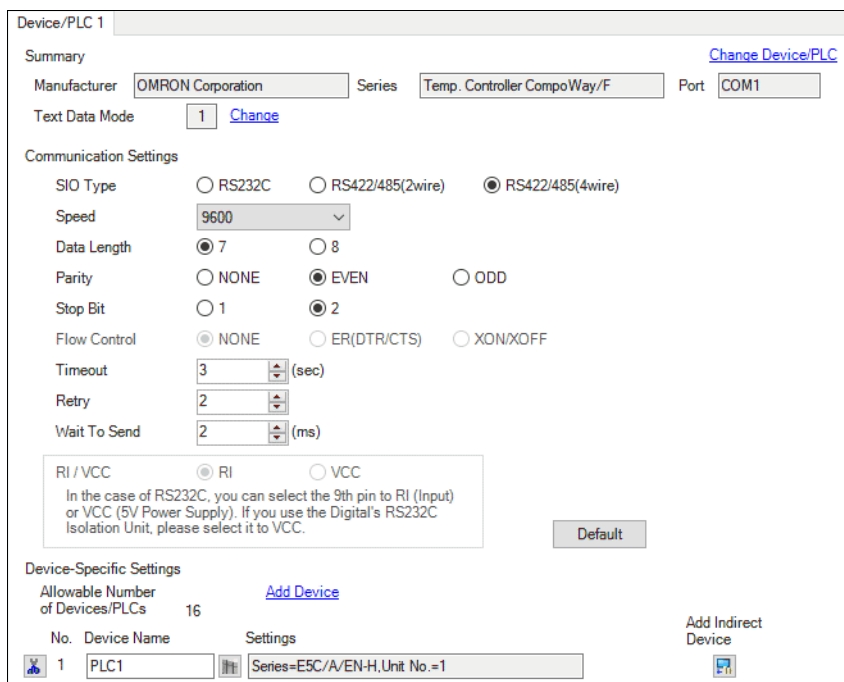

◆ Device Setting

To display the [Individual Device Settings] dialog box, from [Device-Specific Settings] in the [Device/PLC] window, select the external device and click [Settings].

To connect multiple External Devices, from [Device-Specific Settings] in the [Device/PLC] window, click [Add Device] to add another External Device.

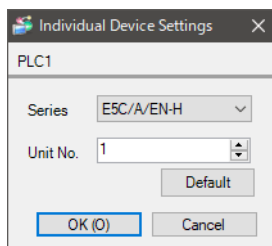

NOTE • Set the HOST link unit No. for "Unit No.".

■ Settings of External Device

Use the level key, mode key, down key and up key in front of the Temperature Controller for communication settings of the External Device.

Please refer to the manual of the Temperature Controller for more details.

◆ Procedure

1. Press and hold the level key (3 minutes or more) to transfer from the operation level to the default level.
2. Press the level key several times to transfer from the default level to the communication setting level.
3. Press the mode key to select the parameter.
4. Press the down/up keys to change the setting.
5. Press and hold the level key to transfer to the operation level.

◆ Setting Value

PSEL	CWF
U-NO	1
BPS	9.6
LEN	7
SBIT	2
PRTY	EVEN
SDWT	2

NOTE

- Parameters to be set vary depending on the Temperature Controller. Please refer to the manual of the Temperature Controller for more details.
- Set Wait to Send to 2ms or more. Finely adjust Wait to Send according to the communication status.

3.9 Setting Example 9

■ Setting of GP-Pro EX

◆ Communication Settings

To display the setup screen, from the [Project] menu, point to [System Settings] and select [Device/PLC].

◆ Device Setting

To display the [Individual Device Settings] dialog box, from [Device-Specific Settings] in the [Device/PLC] window, select the external device and click [Settings] .

To connect multiple External Devices, from [Device-Specific Settings] in the [Device/PLC] window, click [Add Device] to add another External Device.

NOTE • Set the HOST link unit No. for "Unit No.".

■ Settings of External Device

Use the level key, mode key, down key and up key in front of the Temperature Controller for communication settings of the External Device.

Please refer to the manual of the Temperature Controller for more details.

◆ Procedure

1. Press and hold the level key (3 minutes or more) to transfer from the operation level to the default level.
2. Press the level key several times to transfer from the default level to the communication setting level.
3. Press the mode key to select the parameter.
4. Press the down/up keys to change the setting.
5. Press and hold the level key to transfer to the operation level.

◆ Setting Value

PSEL	CWF
U-NO	1
BPS	9.6
LEN	7
SBIT	2
PRTY	EVEN
SDWT	2

NOTE

- Parameters to be set vary depending on the Temperature Controller. Please refer to the manual of the Temperature Controller for more details.
- Set Wait to Send to 2ms or more. Finely adjust Wait to Send according to the communication status.

3.10 Setting Example 10

■ Setting of GP-Pro EX

◆ Communication Settings

To display the setup screen, from the [Project] menu, point to [System Settings] and select [Device/PLC].

◆ Device Setting

To display the [Individual Device Settings] dialog box, from [Device-Specific Settings] in the [Device/PLC] window, select the external device and click [Settings] .

To connect multiple External Devices, from [Device-Specific Settings] in the [Device/PLC] window, click [Add Device] to add another External Device.

NOTE • Set the HOST link unit No. for "Unit No.".

■ Settings of External Device

Use the level key, mode key, down key and up key in front of the Temperature Controller for communication settings of the External Device.

Please refer to the manual of the Temperature Controller for more details.

◆ Procedure

1. Press and hold the level key (3 minutes or more) to transfer from the operation level to the default level.
2. Press the level key several times to transfer from the default level to the communication setting level.
3. Press the mode key to select the parameter.
4. Press the down/up keys to change the setting.
5. Press and hold the level key to transfer to the operation level.

◆ Setting Value

PSEL	CWF
U-NO	1
BPS	9.6
LEN	7
SBIT	2
PRTY	EVEN
SDWT	2

NOTE

- Parameters to be set vary depending on the Temperature Controller. Please refer to the manual of the Temperature Controller for more details.
- Set Wait to Send to 2ms or more. Finely adjust Wait to Send according to the communication status.

3.11 Setting Example 11

■ Setting of GP-Pro EX

◆ Communication Settings

To display the setup screen, from the [Project] menu, point to [System Settings] and select [Device/PLC].

◆ Device Setting

To display the [Individual Device Settings] dialog box, from [Device-Specific Settings] in the [Device/PLC] window, select the external device and click [Settings] .

To connect multiple External Devices, from [Device-Specific Settings] in the [Device/PLC] window, click [Add Device] to add another External Device.

NOTE • Set the HOST link unit No. for "Unit No.".

■ Settings of External Device

Use the level key, mode key, down key and up key in front of the Temperature Controller for communication settings of the External Device.

Please refer to the manual of the Temperature Controller for more details.

◆ Procedure

1. Press and hold the level key (3 minutes or more) to transfer from the operation level to the default level.
2. Press the level key several times to transfer from the default level to the communication setting level.
3. Press the mode key to select the parameter.
4. Press the down/up keys to change the setting.
5. Press and hold the level key to transfer to the operation level.

◆ Setting Value

PSEL	CWF
U-NO	1
BPS	9.6
LEN	7
SBIT	2
PRTY	EVEN
SDWT	2

NOTE

- Parameters to be set vary depending on the Temperature Controller. Please refer to the manual of the Temperature Controller for more details.
- Set Wait to Send to 2ms or more. Finely adjust Wait to Send according to the communication status.

4 Setup Items

Set communication settings of the Display with GP-Pro Ex or in offline mode of the Display.

The setting of each parameter must be identical to that of External Device.

 "3 Example of Communication Setting" (page 9)

4.1 Setup Items in GP-Pro EX

■ Communication Settings

To display the setup screen, from the [Project] menu, point to [System Settings] and select [Device/PLC].

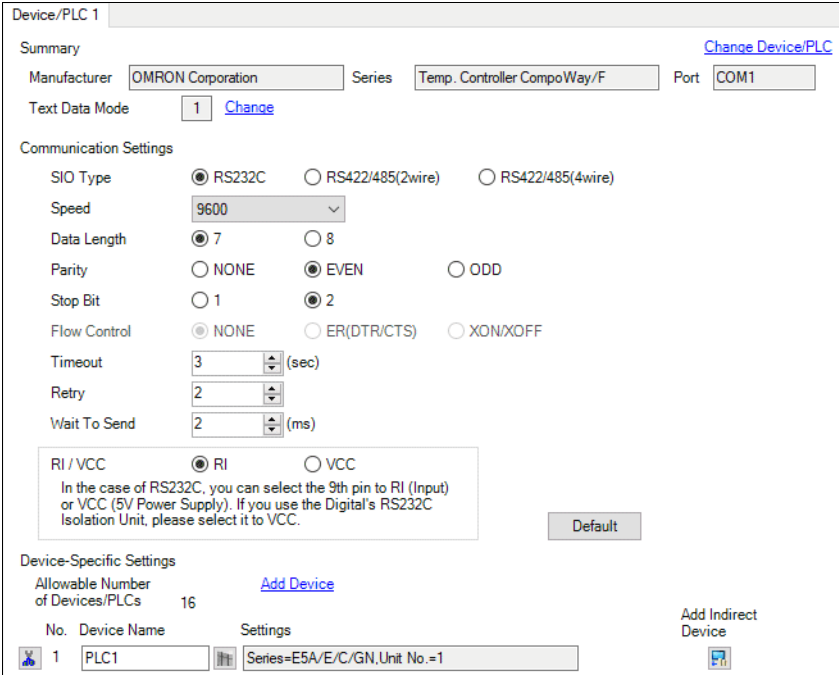

Device/PLC 1 [Change Device/PLC](#)

Summary
 Manufacturer Series Port

Text Data Mode [Change](#)

Communication Settings

SIO Type RS232C RS422/485(2wire) RS422/485(4wire)

Speed

Data Length 7 8

Parity NONE EVEN ODD

Stop Bit 1 2

Flow Control NONE ER(DTR/CTS) XON/XOFF

Timeout (sec)

Retry

Wait To Send (ms)

RI / VCC RI VCC
In the case of RS232C, you can select the 9th pin to RI (Input) or VCC (5V Power Supply). If you use the Digital's RS232C Isolation Unit, please select it to VCC.

Device-Specific Settings

Allowable Number of Devices/PLCs 16 [Add Device](#)

No.	Device Name	Settings	Add Indirect Device
1	PLC1	Series=E5A/E/C/GN,Unit No.=1	<input type="button" value="Add"/>

Setup Items	Setup Description
SIO Type	Select a SIO type for communicating with an external device from "RS232C", "RS422/485 (2-wire)", and "RS422/485 (4-wire)".
Speed	Select speed (bps) between the External Device and the Display.
Data Length	Select the data length (bit) for communication. Select either "7" or "8".
Parity	Select how to check parity. Select any of "None", "Even" and "Odd".
Stop Bit	Select stop bit length. Select either "1" or "2".
Flow Control	The communication control method to prevent overflow of transmission and reception data is displayed.
Timeout	Use an integer from 1 to 127 to enter the time (s) for which the Display waits for the response from the External Device.
Retry	In case of no response from the External Device, use an integer from 0 to 255 to enter how many times the Display retransmits the command.
Wait To Send	Use an integer from 0 to 255 to enter standby time (ms) for the Display from receiving packets to transmitting next commands.

Setup Items	Setup Description
RI/VCC	You can switch RI/VCC of the 9th pin when you select RS232C for SIO type. It is necessary to change RI/5V by changeover switch of IPC when connect with IPC. Please refer to the manual of the IPC for more detail.

■ Device Setting

To display the [Individual Device Settings] dialog box, from [Device-Specific Settings] in the [Device/PLC] window, select the external device and click [Settings] .

To connect multiple External Devices, from [Device-Specific Settings] in the [Device/PLC] window, click [Add Device] to add another External Device.

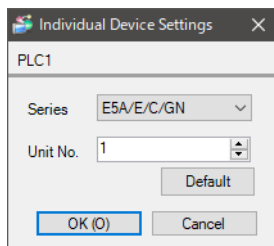

Setup Items	Setup Description
Series	Select a model of the External Device.
Unit No.	Enter the unit No. for HOST link.

4.2 Settings in Offline Mode

- NOTE** • Refer to the Maintenance/Troubleshooting guide for information on how to enter offline mode or about the operation.

Cf. Maintenance/Troubleshooting Guide "Offline Mode"

- The number of the setup items to be displayed for 1 page in the offline mode depends on the Display in use. Please refer to the Reference manual for details.

■ Communication Settings

To display the setting screen, touch [Device/PLC Settings] from [System setting window] in workspace. Touch the External Device you want to set from the displayed list.

Comm.	Device	Option		
Temp. Controller CompoWay/F		[COM1]	Page 1/1	
SIO Type	RS422/485(2wire)			
Speed	9600			
Data Length	<input checked="" type="radio"/> 7 <input type="radio"/> 8			
Parity	<input type="radio"/> NONE <input checked="" type="radio"/> EVEN <input type="radio"/> ODD			
Stop Bit	<input type="radio"/> 1 <input checked="" type="radio"/> 2			
Flow Control	NONE			
Timeout(s)	3			
Retry	2			
Wait To Send(ms)	2			
Exit		Back		2005/12/16 16:55:00

Setup Items	Setup Description
SIO Type	Select a SIO type for communicating with an external device from "RS232C", "RS422/485 (2-wire)", and "RS422/485 (4-wire)". IMPORTANT To make the communication settings correctly, confirm the serial interface specifications of Display unit for [SIO Type]. We cannot guarantee the operation if a communication type that the serial interface does not support is specified. For details concerning the serial interface specifications, refer to the manual for Display unit.
Speed	Select speed (bps) between the External Device and the Display.
Data Length	Select the data length (bit) for communication. Select either "7" or "8".
Parity	Select how to check parity. Select any of "None", "Even" and "Odd".
Stop Bit	Select stop bit length. Select either "1" or "2".
Flow Control	The communication control method to prevent overflow of transmission and reception data is displayed.

Setup Items	Setup Description
Timeout	Use an integer from 1 to 127 to enter the time (s) for which the Display waits for the response from the External Device.
Retry	In case of no response from the External Device, use an integer from 0 to 255 to enter how many times the Display retransmits the command.
Wait To Send	Use an integer from 0 to 255 to enter standby time (ms) for the Display from receiving packets to transmitting next commands.

■ Device Setting

To display the setting screen, touch [Device/PLC Settings] from [Peripheral Equipment Settings]. Touch the External Device you want to set from the displayed list, and touch [Device Settings].

Comm.	Device	Option		
Temp. Controller CompoWay/F		[COM1]	Page 1/1	
Device/PLC Name		[PLC1] ▼		
Series		E5A/E/C/GN		
Unit No.		[1] ▼ ▲		
Exit		Back		2005/12/16 16:55:02

Setup Items	Setup Description
Device/PLC name	Select the External Device to set. Device name is a title of the External Device set with GP-Pro EX. (Default value [PLC1])
Series	Displays a model of the External Device.
Unit No.	Enter the unit No. for HOST link.

■ Option

To display the setting screen, touch [Device/PLC Settings] from [Peripheral Settings]. Touch the External Device you want to set from the displayed list, and touch [Option].

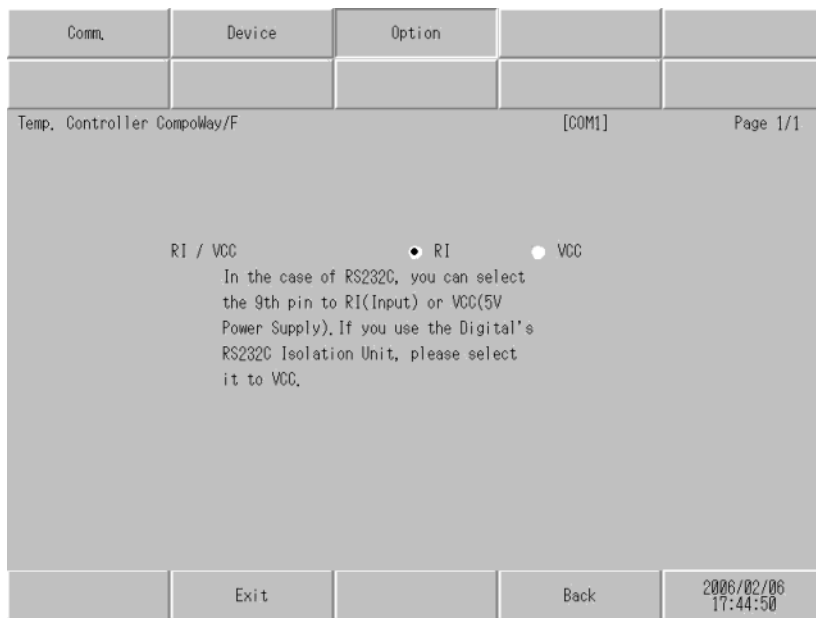

Setup Items	Setup Description
RI/VCC	Switches RI/VCC of the 9th pin. It is necessary to change RI/5V by changeover switch of IPC when connect with IPC. Please refer to the manual of the IPC for more detail.

NOTE

- GP-4100 series, GP-4*01TM, GP-Rear Module, LT-4*01TM and LT-Rear Module do not have the [Option] setting in the offline mode.

5 Cable Diagram

The cable diagram shown below may be different from the cable diagram recommended by OMRON Corporation. Please be assured there is no operational problem in applying the cable diagram shown in this manual.

- The FG pin of the main body of the External Device must be D-class grounded. Please refer to the manual of the External Device for more details.
- SG and FG are connected inside the Display. When connecting SG to the External Device, design the system not to form short-circuit loop.
- Connect the isolation unit, when communication is not stabilized under the influence of a noise etc..

Recommended cable

- RS232C

Temperature Controller	Cable
E5EN-□□□□□-FLK E5AN-□□□□□-FLK	Twist pair shield cable AWG28 or higher

- RS485

Temperature Controller	Cable
E5EN-□□□□□-FLK E5AN-□□□□□-FLK E5CN-□□□□□-FLK E5AR-□□□□□□□□□-FLK E5ER-□□□□□□□□□-FLK	AWG28 or higher
E5GN-□□□□□-FLK E5ZN-□□□□□-FLK	AWG24 to 14

Cable Diagram 1

Display (Connection Port)	Cable		Remarks
GP3000 (COM1) GP4000*1 (COM1) SP5000*2 (COM1/2) SP-5B00 (COM1) ST3000 (COM1) ST6000 (COM1) LT3000 (COM1) IPC*3 PC/AT	1A	User-created cable	Cable length: 15m or less
GP-4105 (COM1) GP-4115T (COM1) GP-4115T3 (COM1)	1B	User-created cable	Cable length: 15m or less
LT-4*01TM (COM1) LT-Rear Module (COM1)	1C	RJ45 RS-232C Cable (5m) by Pro-face PFXZLMCBRJ21	Cable length: 5m or less

*1 All GP4000 models except GP-4100 Series and GP-4203T

*2 Except SP-5B00

*3 Only the COM port which can communicate by RS-232C can be used.

 ■ IPC COM Port (page 5)

1A)

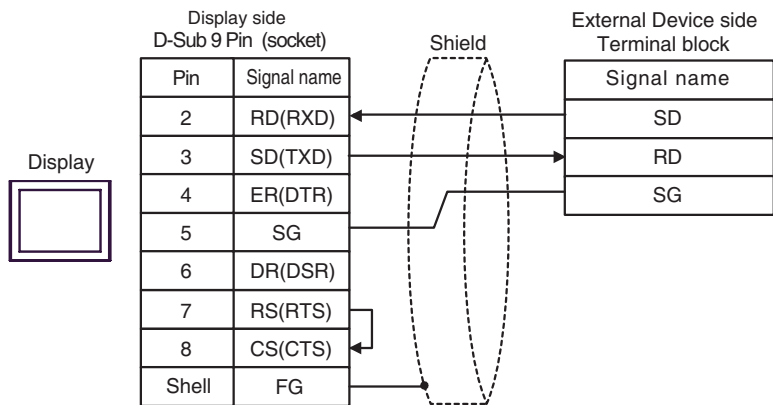

1B)

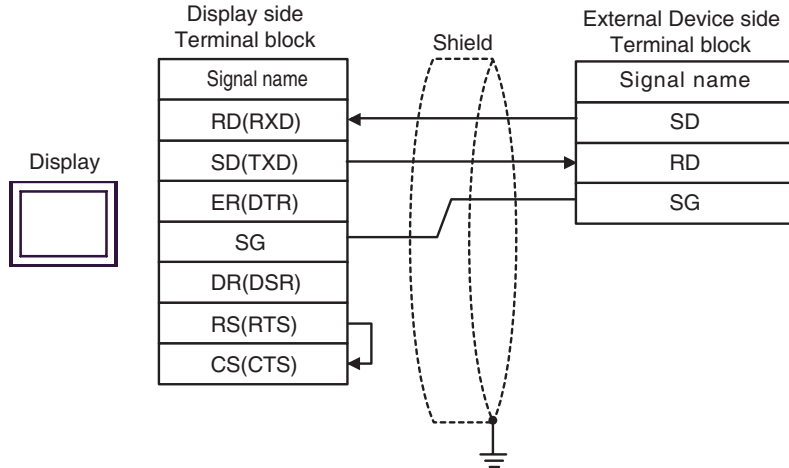

1C)

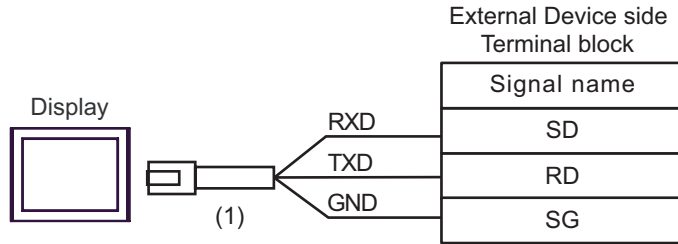

Number	Name	Notes
(1)	RJ45 RS-232C Cable (5m) by Pro-face PFXZLMCBJR21	

Cable Diagram 2

Display (Connection Port)	Cable		Remarks
GP3000* ¹ (COM1) AGP-3302B (COM2) GP-4*01TM (COM1) GP-Rear Module (COM1) ST3000* ² (COM2) LT3000 (COM1)	2A	COM port conversion adapter by Pro-face CA3-ADPCOM-01 + Terminal block conversion adapter by Pro-face CA3-ADPTRM-01 + User-created cable	Cable length: 500m or less
	2B	User-created cable	
GP3000* ³ (COM2)	2C	Online adapter by Pro-face CA4-ADPONL-01 + Terminal block conversion adapter by Pro-face CA3-ADPTRM-01 + User-created cable	Cable length: 500m or less
	2D	Online adapter by Pro-face CA4-ADPONL-01 + User-created cable	
IPC* ⁴	2E	COM port conversion adapter by Pro-face CA3-ADPCOM-01 + Terminal block conversion adapter by Pro-face CA3-ADPTRM-01 + User-created cable	Cable length: 500m or less
	2F	User-created cable	
GP-4106 (COM1) GP-4116T (COM1)	2G	User-created cable	Cable length: 500m or less
GP-4107 (COM1) GP-4*03T* ⁵ (COM2) GP-4203T (COM1)	2H	User-created cable	Cable length: 500m or less
GP4000* ⁶ (COM2) GP-4201T (COM1) SP5000* ⁷ (COM1/2) SP-5B00 (COM2) ST6000* ⁸ (COM2) ST-6200 (COM1)	2I	RS-422 terminal block conversion adapter by Pro-face PFXZCBADTM1* ⁹ + User-created cable	Cable length: 500m or less
	2B	User-created cable	
LT-4*01TM (COM1) LT-Rear Module (COM1)	2J	RJ45 RS-485 Cable (5m) by Pro-face PFXZLMCBJR81	Cable length: 200m or less
PE-4000B* ¹⁰ PS5000* ¹⁰	2K	User-created cable	Cable length: 500m or less

*1 All GP3000 models except AGP-3302B

*2 Except AST-3211A and AST-3302B

- *3 All GP3000 models except GP-3200 series and AGP-3302B
- *4 Only the COM port which can communicate by RS-422/485 (2 wire) can be used. (Except PE-4000B, PS5000)
☞ ■ IPC COM Port (page 5)
- *5 Except GP-4203T
- *6 All GP4000 models except GP-4100 series, GP-4*01TM, GP-Rear Module, GP-4201T and GP-4*03T
- *7 Except SP-5B00
- *8 Except ST-6200
- *9 When using a Terminal Block Conversion Adapter (CA3-ADPTRM-01) instead of the RS-422 Terminal Block Conversion Adapter, refer to Cable Diagram 2A.
- *10 Only the COM port which can communicate by RS-422/485 (2 wire) can be used.
☞ ■ IPC COM Port (page 5)

2A)

- 1:1 Connection

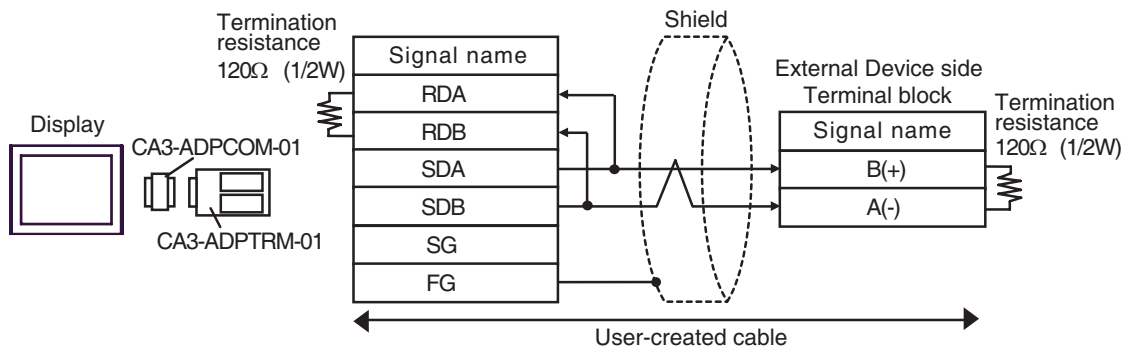

- 1: n connection

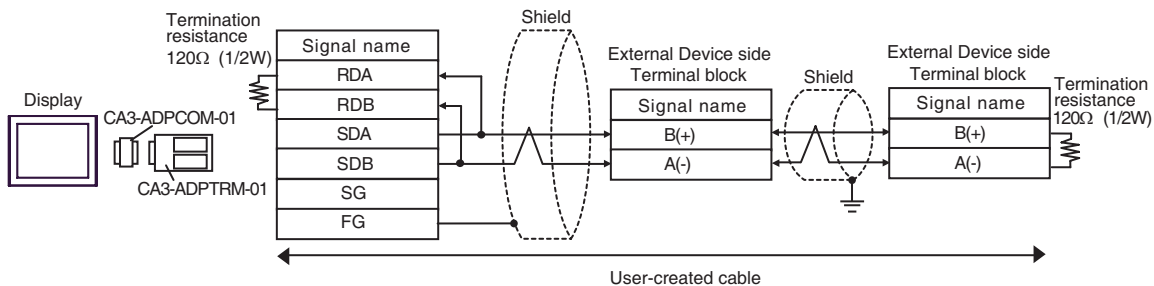

2B)

- 1:1 Connection

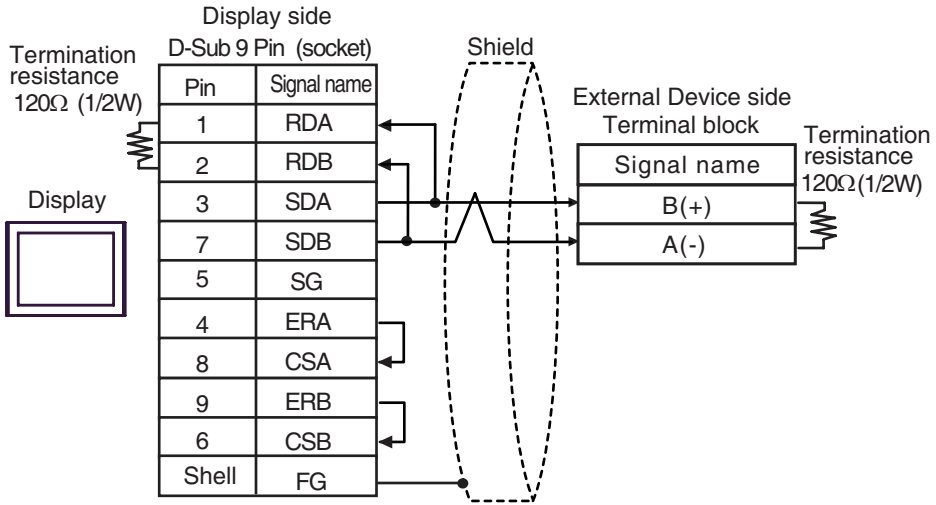

- 1:n Connection

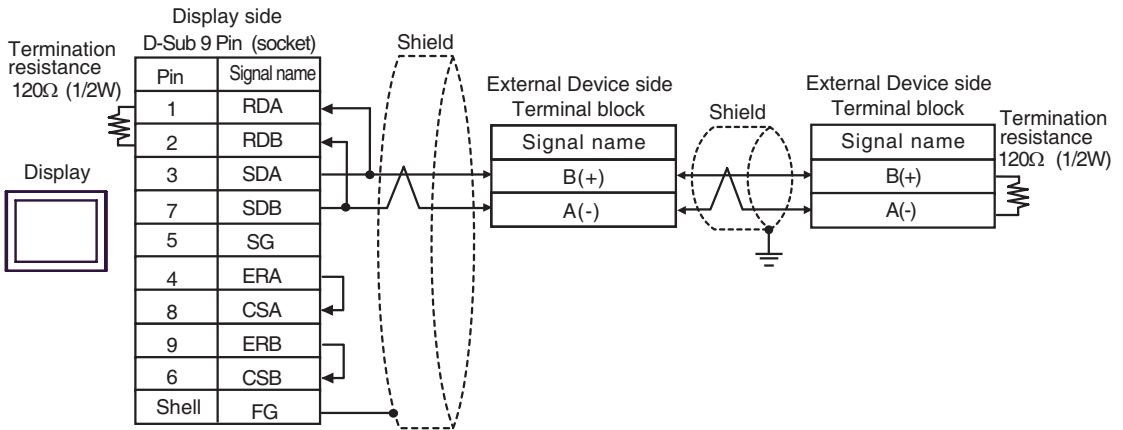

2C)

- 1:1 Connection

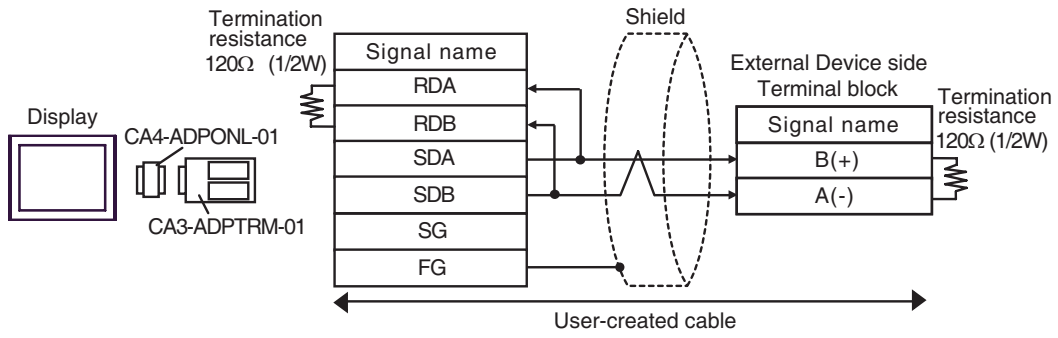

- 1:n Connection

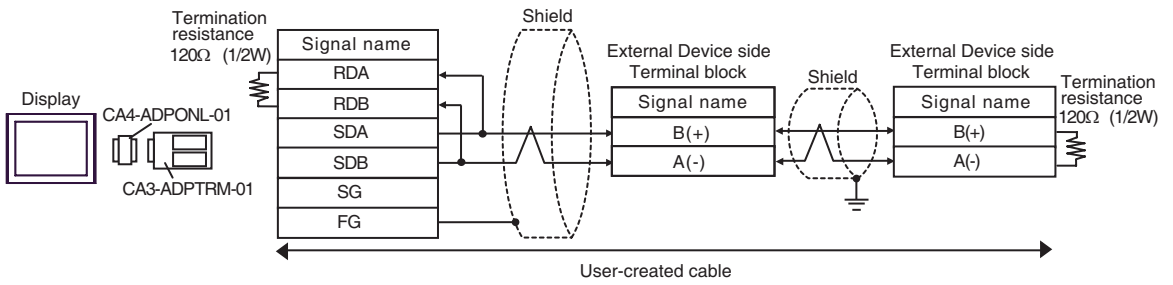

2D)

- 1:1 Connection

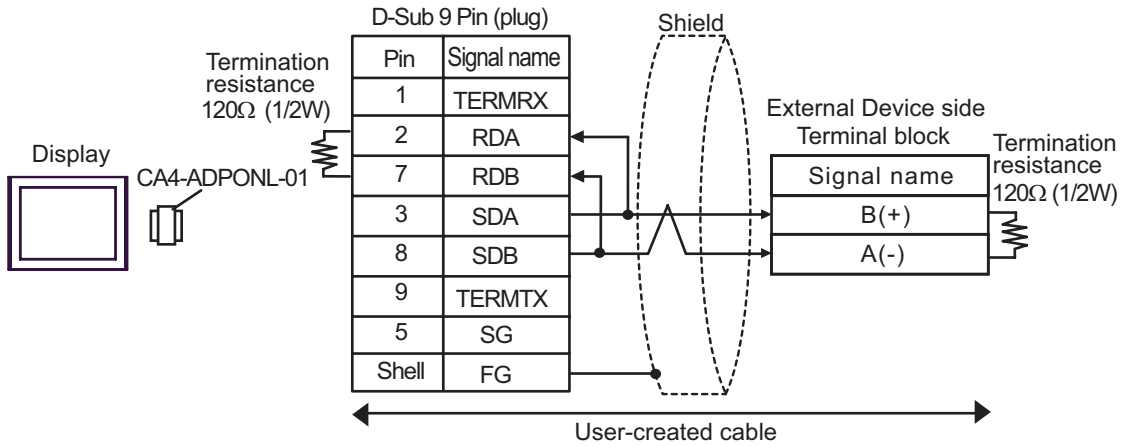

- 1:n Connection

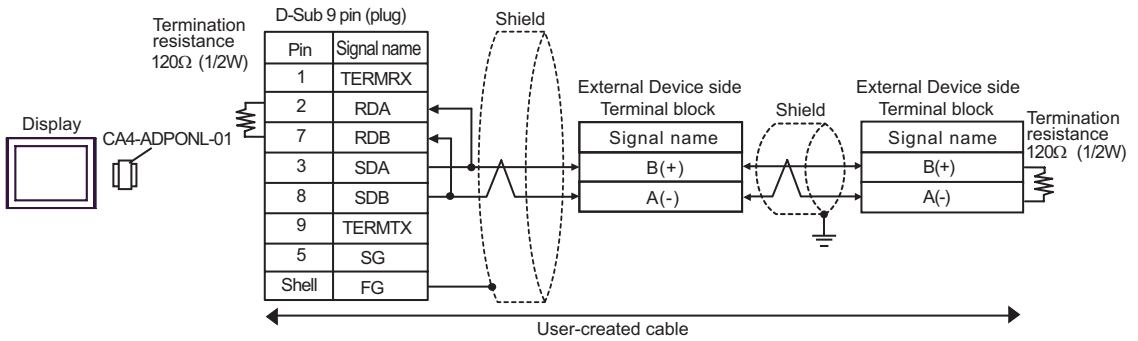

2E)

- 1:1 Connection

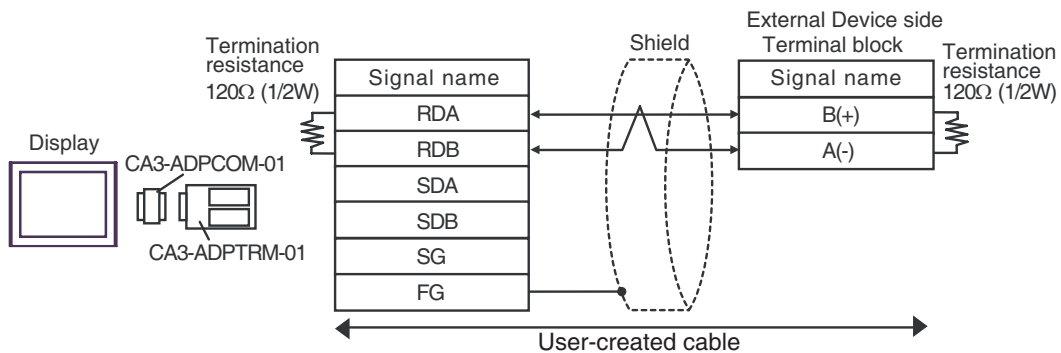

- 1: n connection

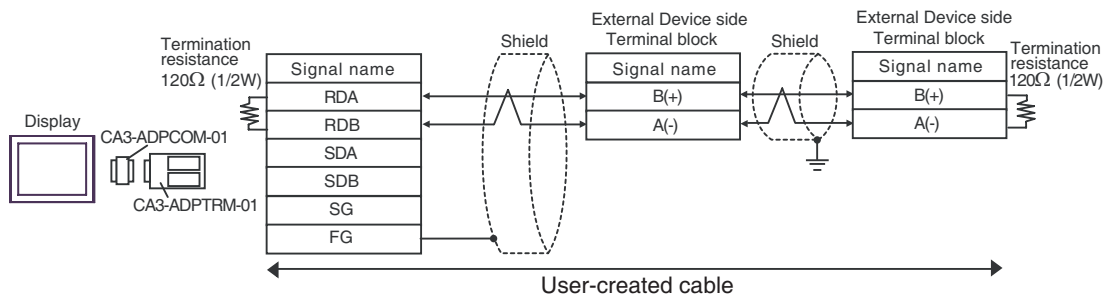

2F)

- 1:1 Connection

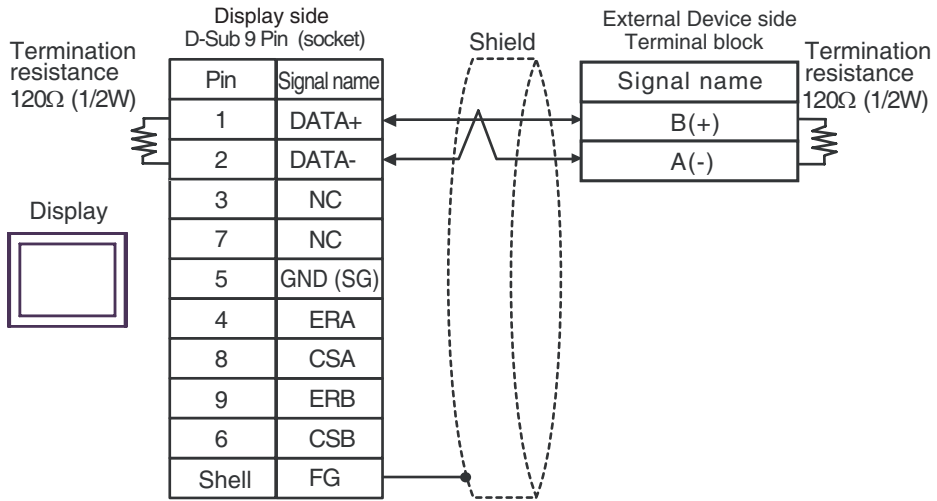

- 1:n Connection

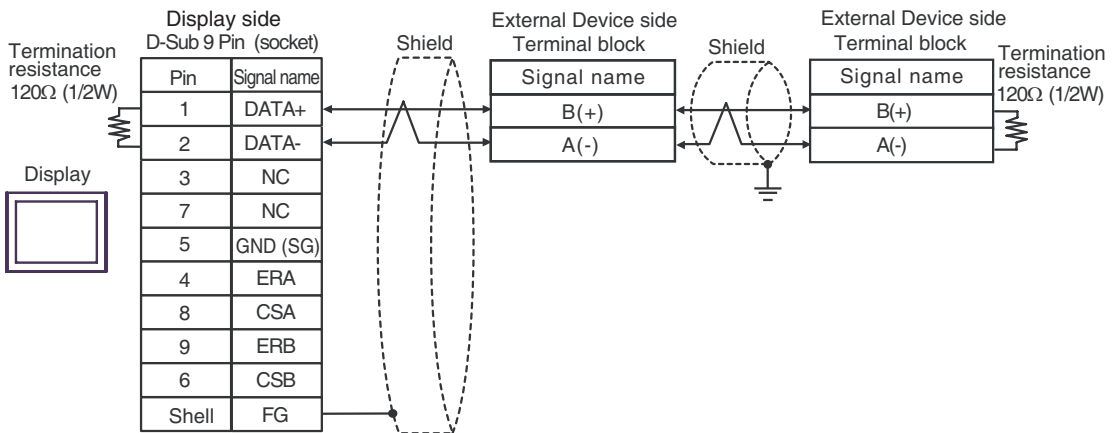

2G)

- 1:1 Connection

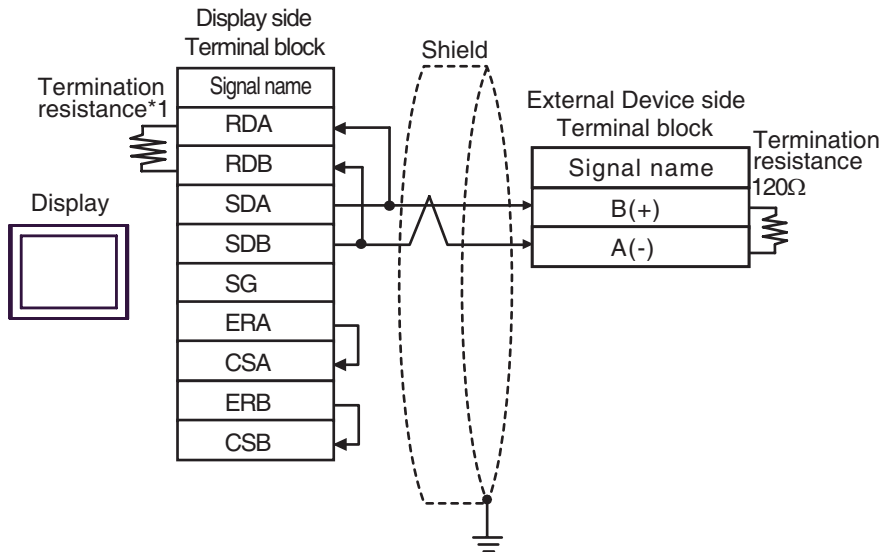

- 1:n Connection

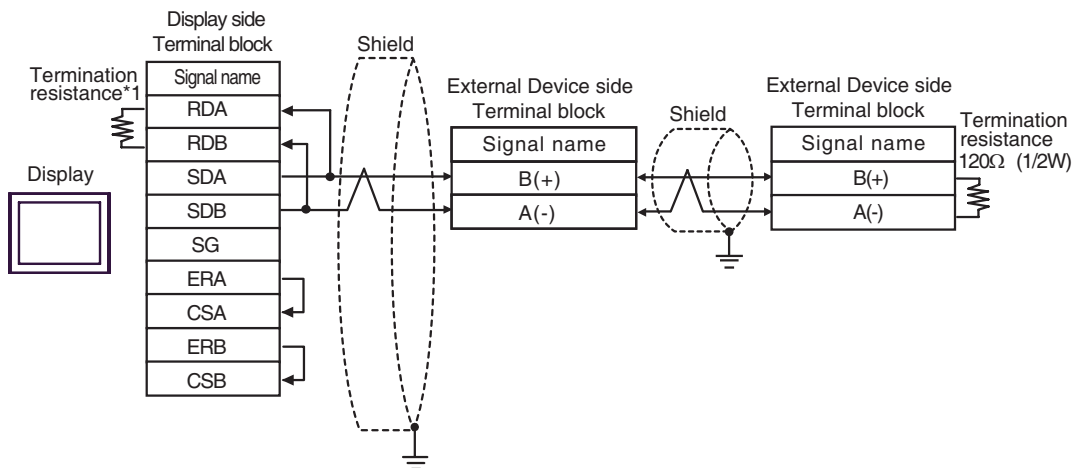

*1 The resistance in the Display is used as the termination resistance. Set the value of the DIP Switch on the rear of the Display as shown in the table below.

DIP Switch No.	Set Value
1	OFF
2	OFF
3	ON
4	ON

2H)

- 1:1 Connection

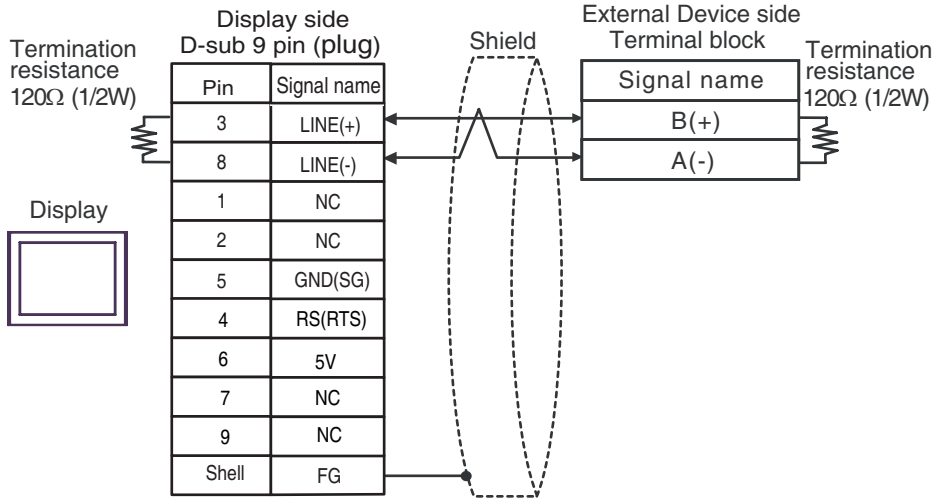

- 1:n Connection

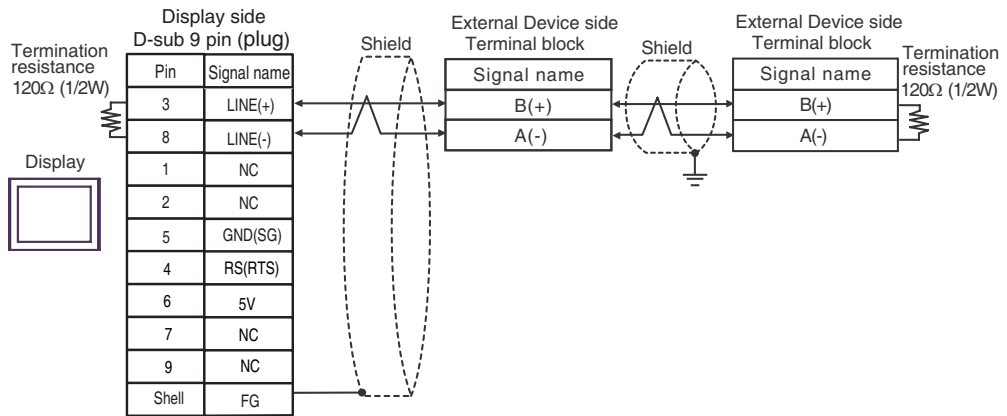

IMPORTANT • The 5V output (Pin #6) on the Display is the power for the Siemens AG's PROFIBUS connector. Do not use it for other devices.

NOTE • In COM on the GP-4107, the SG and FG terminals are isolated.

2I)

- 1:1 Connection

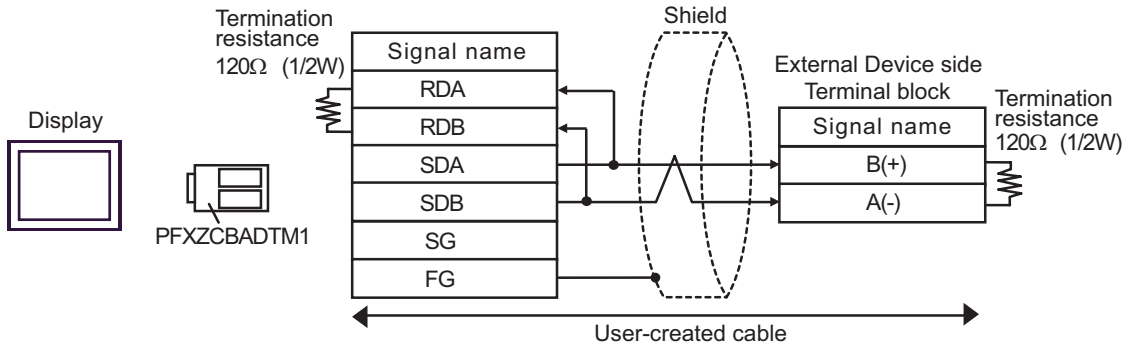

- 1: n connection

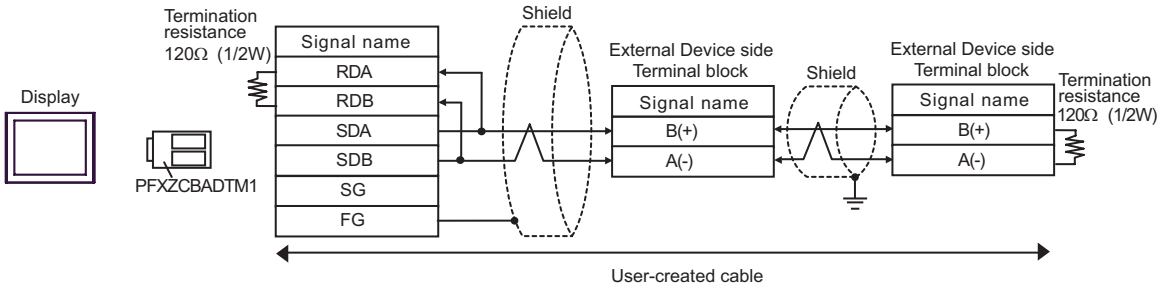

2J)

- 1:1 Connection

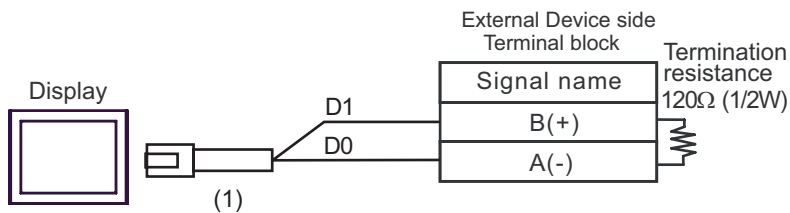

- 1:n Connection

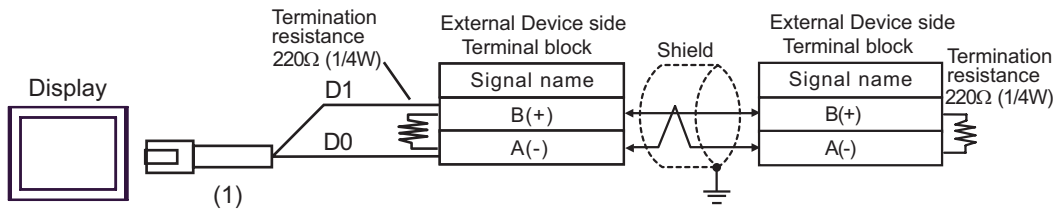

Number	Name	Notes
(1)	RJ45 RS-485 Cable (5m) by Pro-face PFXZLMCBRJ81	

2K)

- 1:1 Connection

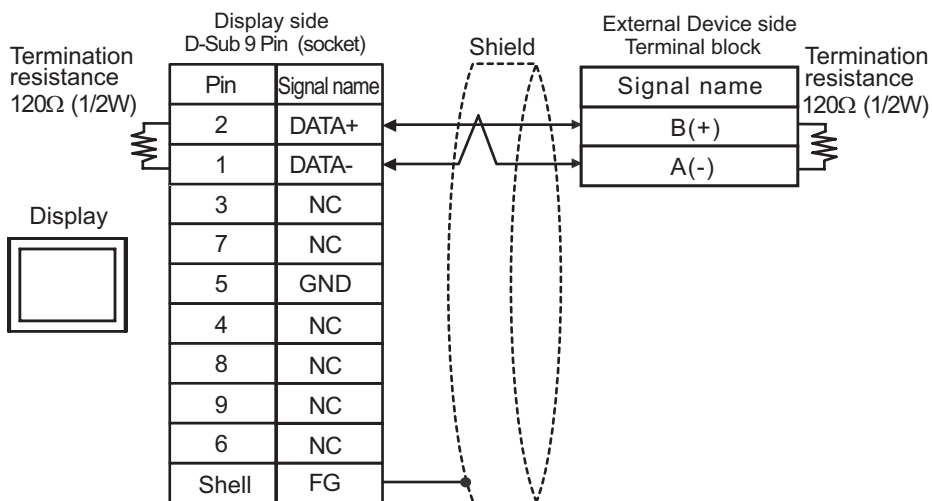

- 1:n Connection

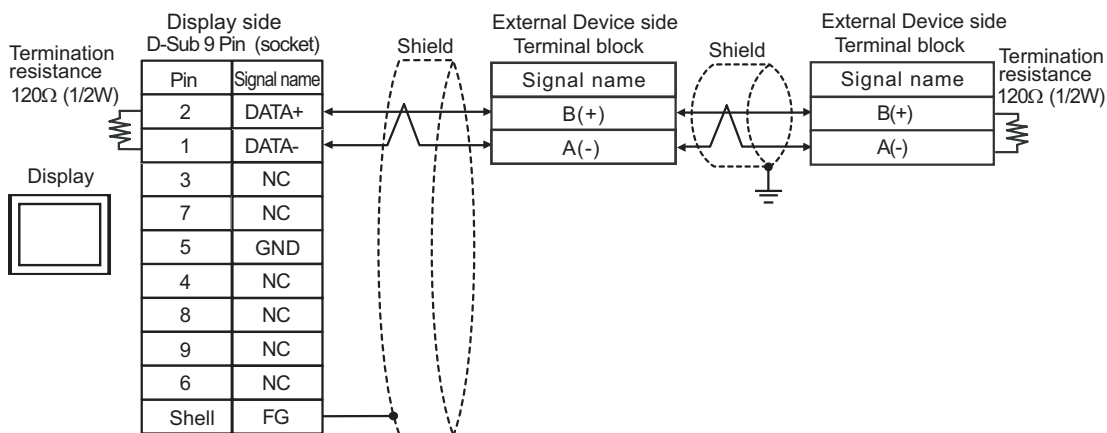

Cable Diagram 3

Display (Connection Port)	Cable		Remarks
GP3000* ¹ (COM1) AGP-3302B (COM2) GP-4*01TM (COM1) GP-Rear Module (COM1) ST3000* ² (COM2) LT3000 (COM1) IPC* ³	3A	COM port conversion adapter by Pro-face CA3-ADPCOM-01 + Terminal block conversion adapter by Pro-face CA3-ADPTRM-01 + User-created cable	Cable length: 500m or less
	3B	User-created cable	
GP3000* ⁴ (COM2)	3C	Online adapter by Pro-face CA4-ADPONL-01 + Terminal block conversion adapter by Pro-face CA3-ADPTRM-01 + User-created cable	Cable length: 500m or less
	3D	Online adapter by Pro-face CA4-ADPONL-01 + User-created cable	
GP-4106 (COM1) GP-4116T (COM1)	3E	User-created cable	Cable length: 500m or less
GP4000* ⁵ (COM2) GP-4201T (COM1) SP5000* ⁶ (COM1/2) SP-5B00 (COM2) ST6000* ⁷ (COM2) ST-6200 (COM1)	3F	RS-422 terminal block conversion adapter by Pro-face PFXZCBADTM1* ⁸ + User-created cable	Cable length: 500m or less
	3B	User-created cable	
PE-4000B* ⁹ PS5000* ⁹	3G	User-created cable	Cable length: 500m or less

*1 All GP3000 models except AGP-3302B

*2 Except AST-3211A and AST-3302B

*3 Only the COM port which can communicate by RS-422/485 (2 wire) can be used. (Except PE-4000B, PS5000)
 ■ IPC COM Port (page 5)

*4 All GP3000 models except GP-3200 series and AGP-3302B

*5 All GP4000 models except GP-4100 series, GP-4*01TM, GP-Rear Module, GP-4201T and GP-4*03T

*6 Except SP-5B00

*7 Except ST-6200

*8 When using a Terminal Block Conversion Adapter (CA3-ADPTRM-01) instead of the RS-422 Terminal Block Conversion Adapter, refer to Cable Diagram 2A.

*9 Only the COM port which can communicate by RS-422/485 (2 wire) can be used.
 ■ IPC COM Port (page 5)

3A)

- 1:1 Connection

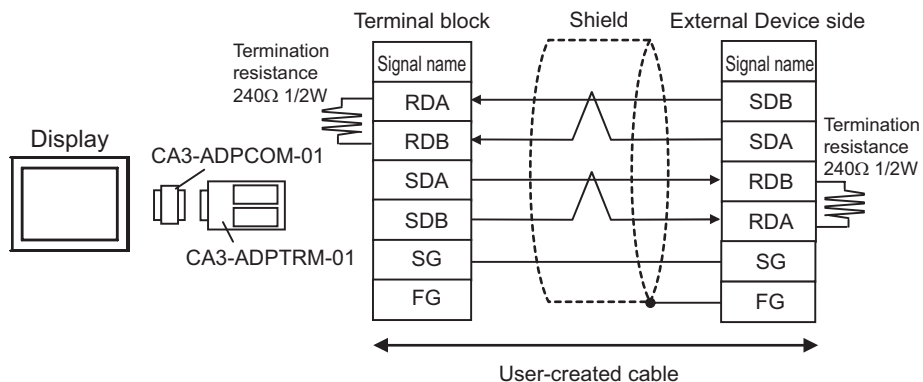

- 1:n connection

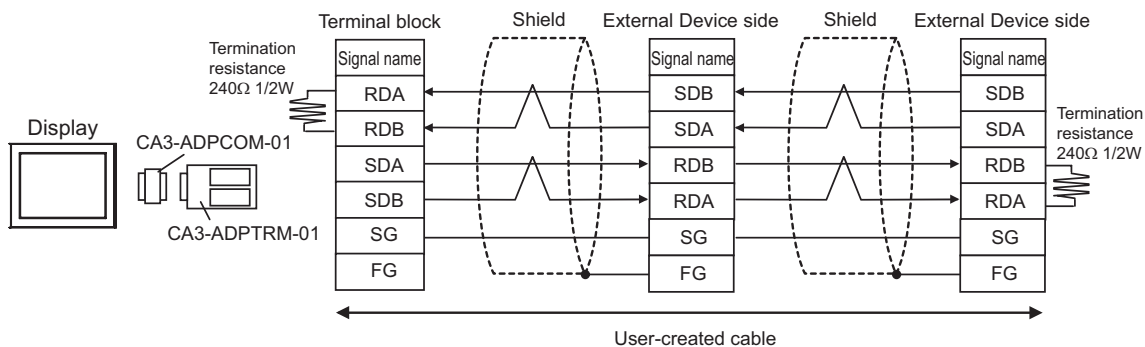

3B)

- 1:1 Connection

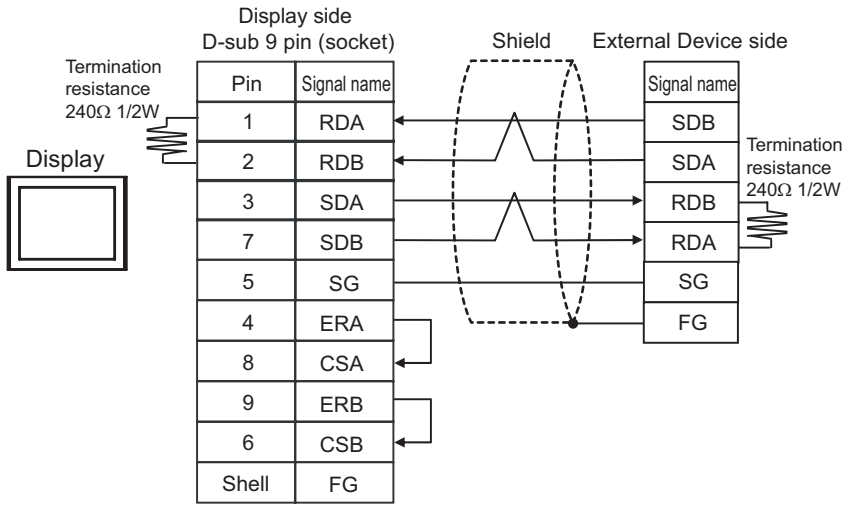

- 1: n connection

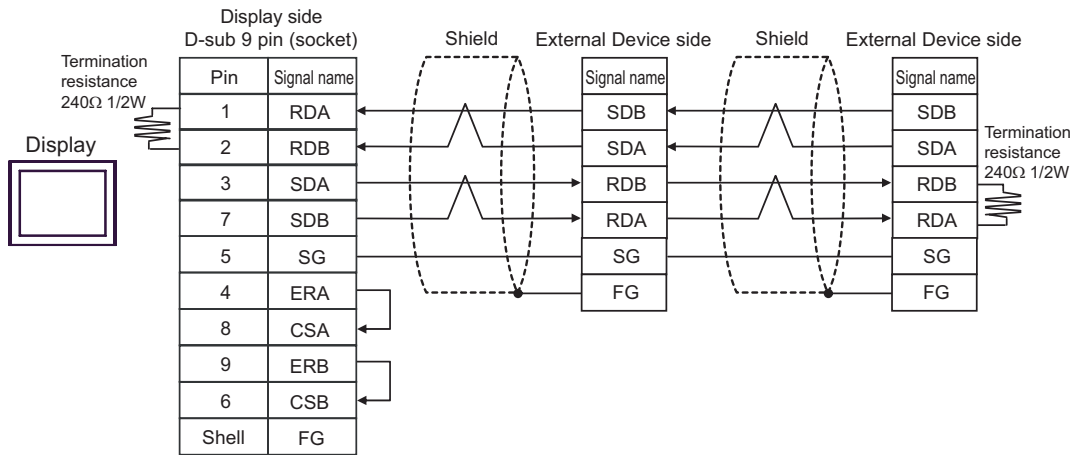

3C)

- 1:1 Connection

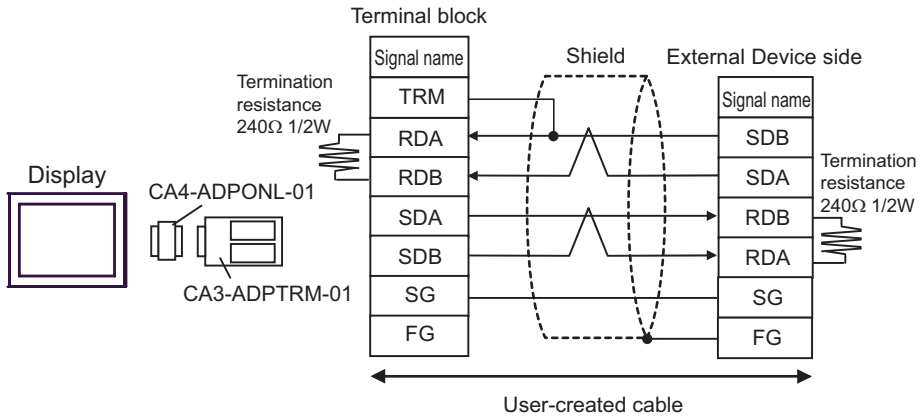

- 1: n connection

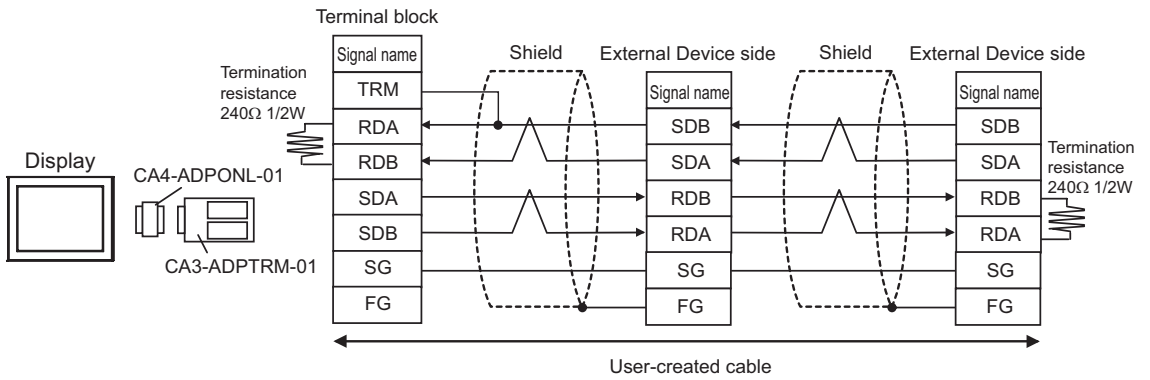

3D)

- 1:1 Connection

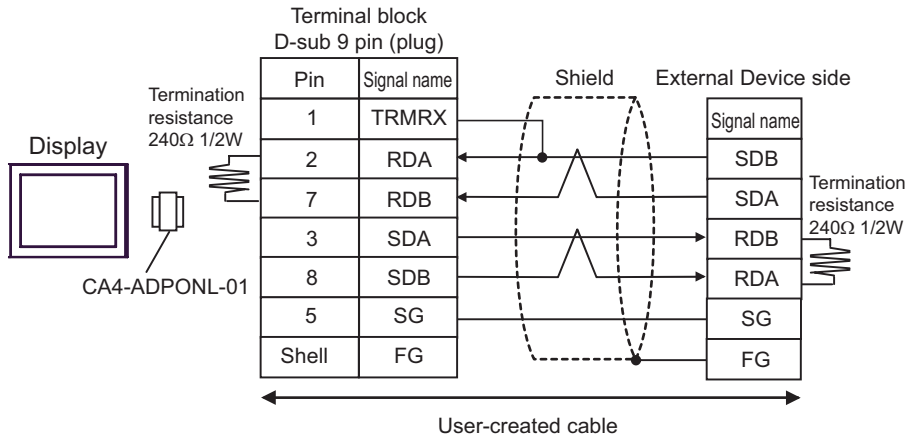

- 1: n connection

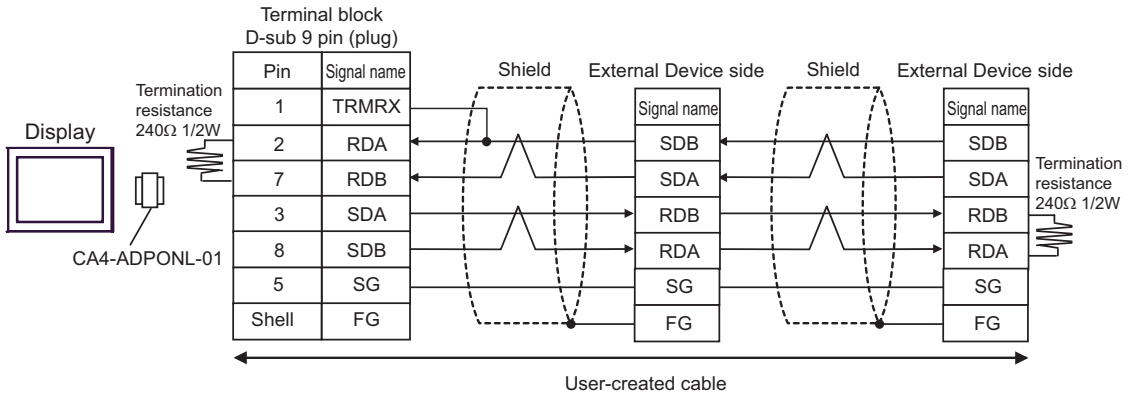

3E)

- 1:1 Connection

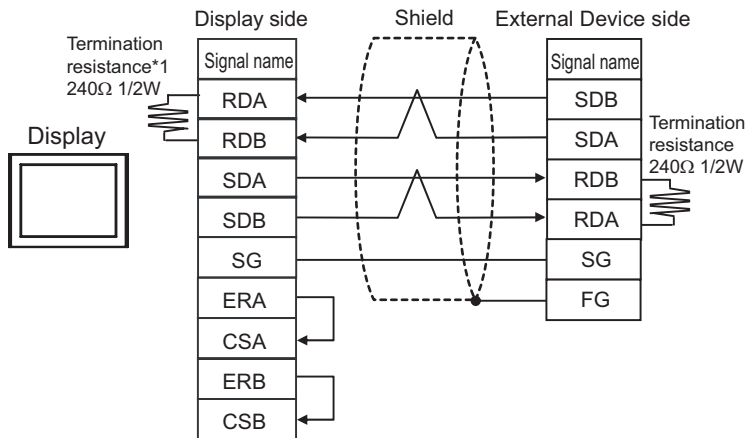

- 1: n connection

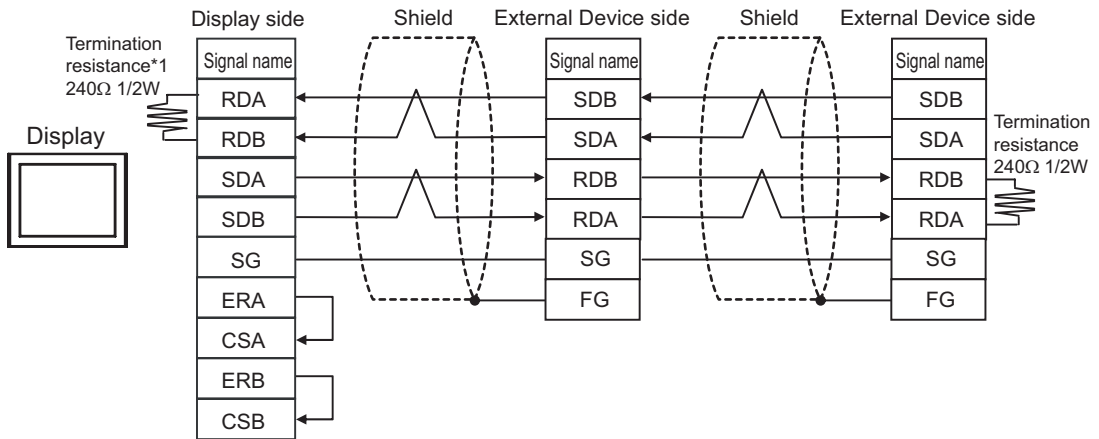

*1 The resistance in the Display is used as the termination resistance. Set the value of the DIP Switch on the rear of the Display as shown in the table below.

DIP Switch No.	Set Value
1	ON
2	OFF
3	ON
4	OFF

3F)

- 1:1 Connection

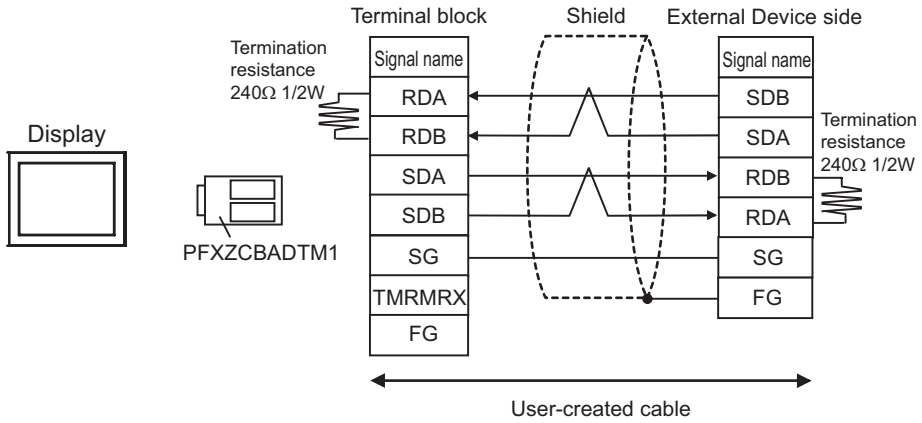

- 1: n connection

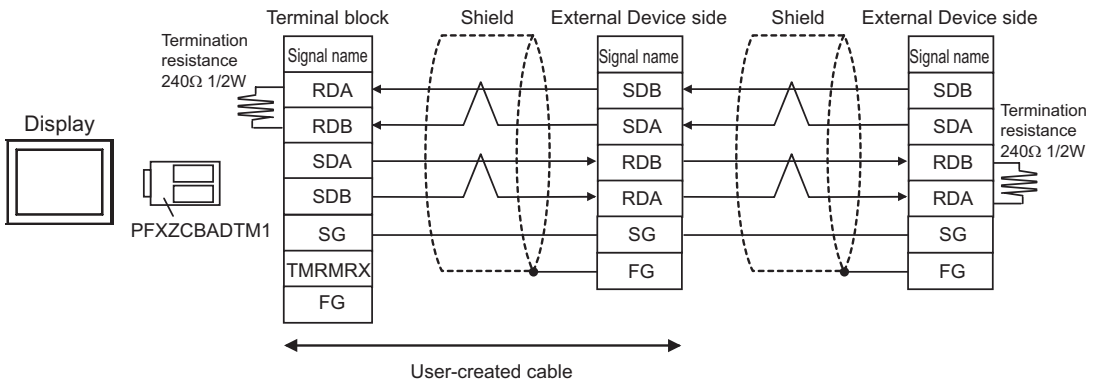

3G)

- 1:1 Connection

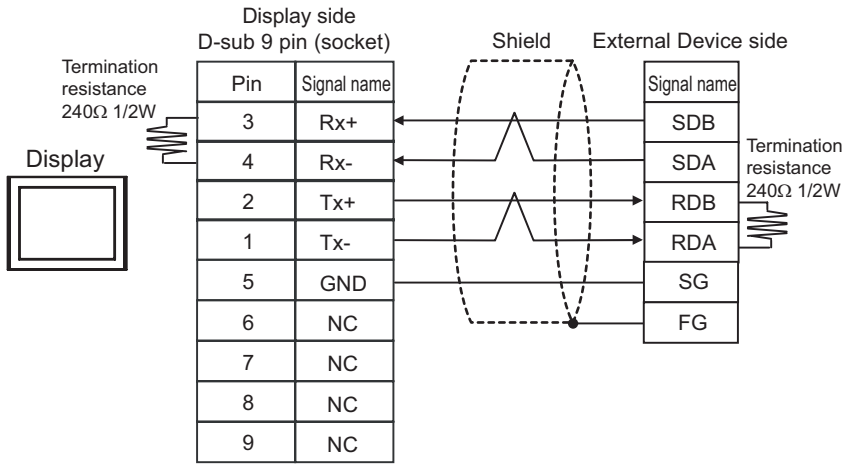

- 1: n connection

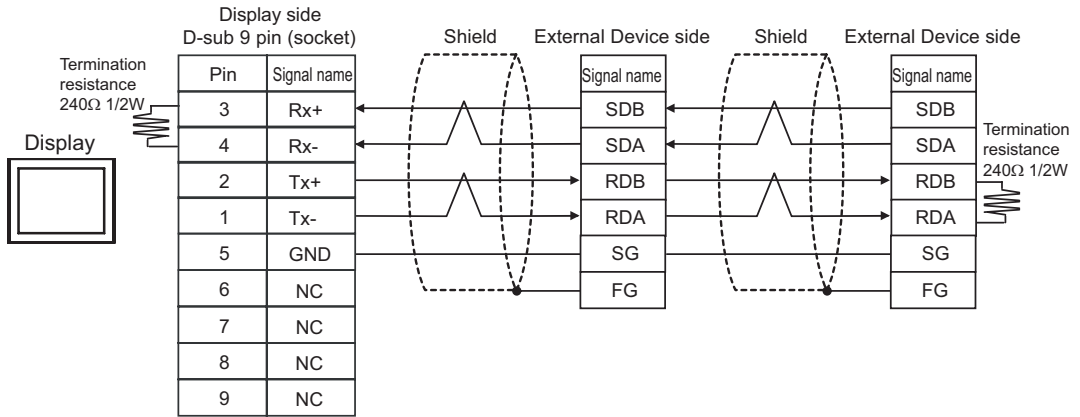



6 Supported device

Range of supported device address is shown in the table below. Please note that the actually supported range of the devices varies depending on the External Device to be used. Please check the actual range in the manual of your External Device.

6.1 THERMAC NEO (E5AN/E5EN/E5CN/E5GN)

 This address can be specified as system data area.

Device	Bit Address		Word Address		32bit	Remarks
	11-segment display	7-segment display	11-segment display	7-segment display		
Variable Areas*1	C00000.00- C00009.31	C00000.00- C00005.31	C00000- C00009	C00000- C00005		Double Word Device*2*3
	C10000.00- C1002A.31	C10000.00- C1001C.31	C10000- C1002A	C10000- C1001C		Double Word Device*2
	C30000.00- C30056.31	C30000.00- C30037.31	C30000- C30056	C30000- C30037		Double Word Device*2*4
Operation command*6	-	-	A0000- A0011	A0000- A0008		Word Device*5 

*1 Available variable area range varies depending on the using Temperature Controller. Refer to the manual of OMRON Temperature Controller for setting.

*2 When you write the bit address, the Display reads the word address corresponding to that of the External Device first. Then, it changes the target bit address among the word data once read and returns the word data to the External Device. Note that the correct data may not be written if you change the word address value in the ladder program while the Display reads the data of the External Device and returns it to the External Device.

*3 Write disable

*4 When writing, switch the setting area of the Temperature Controller to setting area 1.

*5 Read disable

*6 When executing the operation command (write), specify the directive code for the device address. Set the related information for the writing value. Set the related information in hexadecimal number, such as 0x00, 0x01. Set the device code to be used in the painting software as A, and enter each command code instead of the device address.

■ Command code list

Command code	Related information	Command comment	Device address
00	00: OFF(Disabled) 01: ON (Enabled)	Communication writing	A0000
01	00: Run 01: Stop	Run/Stop	A0001
02	00: Target value 0 01: Target value 1 02: Target value 2 03: Target value 3	Multi-SP	A0002
03	00: Cancel 01: AT execute	ATexecute/cancel	A0003
04	00: Backup 01: RAM	Write mode	A0004
05	00	Save RAM data	A0005

Command code	Related information	Command comment	Device address
06	00	Soft reset *1	A0006
07	00	Setting area 1 transfer	A0007
08	00	Protect level transfer	A0008
09	00: Auto mode 01: Manual mode	Auto/Manual	A0009
0B	00: Default value 01: Value for default value setting service	Initialize settings	A000B
11	00: Reset 01: Start	Program start	A0011

*1 A soft reset will not respond.

IMPORTANT



- To enable "Use System Area" in the system area setting of GP-Pro EX may cause a malfunction. Do not set "Use System Area".
-

NOTE

- You can set only Read Area Size for the system area available to use in the Temperature Controller. Please refer to the GP-Pro EX Reference Manual for Read Area Size.
Cf. GP-Pro EX Reference Manual "LS Area (Direct Access Method Area)"
 - Please refer to the precautions on manual notation for icons in the table.
☞ "Manual Symbols and Terminology"
 - Even if you use the nonexistent address, read error may not be displayed. In this case, "0" is retained for the read data. Note that the writing error is displayed.
-

6.2 THERMAC NEO (E5AN-H/E5EN-H/E5CN-H)

 This address can be specified as system data area.

Device	Bit Address	Word Address	32bit	Remarks
Variable Areas ^{*1}	C00000.00-C00013.31	C00000-C00013		Double Word Device ^{*2*3}
	C10000.00-C10031.31	C10000-C10031		Double Word Device ^{*2}
	C30000.00-C300CE.31	C30000-C300CE		Double Word Device ^{*2*4}
	C40000.00-C4007E.31	C40000-C4007E		Double Word Device ^{*2}
	C50000.00-C50077.31	C50000-C50077		Double Word Device ^{*2}
Operation command ^{*6}	-	A0000-A0012		Word Device ^{*5} 

*1 Available variable area range varies depending on the using Temperature Controller. Refer to the manual of OMRON Temperature Controller for setting.

*2 When you write the bit address, the Display reads the word address corresponding to that of the External Device first. Then, it changes the target bit address among the word data once read and returns the word data to the External Device. Note that the correct data may not be written if you change the word address value in the ladder program while the Display reads the data of the External Device and returns it to the External Device.

*3 Write disable

*4 When writing, switch the setting area of the Temperature Controller to setting area 1.

*5 Read disable

*6 When executing the operation command (write), specify the directive code for the device address. Set the related information for the writing value. Set the related information in hexadecimal number, such as 0x00, 0x01. Set the device code to be used in the painting software as A, and enter each command code instead of the device address.

■ Command code list

Command code	Related information	Command comment	Device address
00	00: OFF (Disabled) 01: ON (Enabled)	Communication writing	A0000
01	00: Run 01: Stop	Run/Stop	A0001
02	00: Bank 0 01: Bank 1 02: Bank 2 03: Bank 3 04: Bank 4 05: Bank 5 06: Bank 6 07: Bank 7	Bank Change	A0002
03	00: AT Cancel 01: 100% AT execute 02: 40% AT execute	AT Execute/Cancel	A0003
04	00: Backup mode 01: RAM write mode	Write Mode	A0004
05	00	Save RAM data	A0005
06	00	Software Reset	A0006
07	00	Move to Setup Area 1	A0007
08	00	Move to Protect Level	A0008

Command code	Related information	Command comment	Device address
09	00: Automatic mode 01: Manual mode	Auto/Manual Switch	A0009
0B	00: Initialize to defaults	Parameter Initialization	A000B
0C	00: Alarm 1 latch cancel 01: Alarm 2 latch cancel 02: Alarm 3 latch cancel 03: HB alarm latch cancel 04: HS alarm latch cancel 05: OC alarm latch cancel 0F: All alarm latch cancel	Alarm Latch Cancel	A000C
0D	00: Local SP Mode 01: Remote SP Mode	SP Mode	A000D
0E	00: Not invert 01: Invert	Invert Direct/Reverse Operation	A000E
11	00: Reset 01: Start	Program start	A0011
12	00:OFF 01:ON	Infrared Communication Use	A0012

IMPORTANT

- To enable "Use System Area" in the system area setting of GP-Pro EX may cause a malfunction. Do not set "Use System Area".

NOTE

- You can set only Read Area Size for the system area available to use in the Temperature Controller. Please refer to the GP-Pro EX Reference Manual for Read Area Size.
Cf. GP-Pro EX Reference Manual "LS Area (Direct Access Method Area)"
- Please refer to the precautions on manual notation for icons in the table.
 "Manual Symbols and Terminology"
- Even if you use the nonexistent address, read error may not be displayed. In this case, "0" is retained for the read data. Note that the writing error is displayed.

6.3 THERMAC R (E5AR/E5ER)

 This address can be specified as system data area.

Device	Bit Address	Word Address	32bit	Remarks
Variable Areas ^{*1}	C00000.00-C00002.31 C00004.00-C00005.31 C00100.00-C00102.31 C00104.00-C00105.31 C00200.00-C00202.31 C00204.00-C00205.31 C00300.00-C00302.31 C00304.00-C00305.31	C00000-C00002 C00004-C00005 C00100-C00102 C00104-C00105 C00200-C00202 C00204-C00205 C00300-C00302 C00304-C00305		Double Word Device ^{*2*3}
	C10003.00-C10009.31 C10103.00-C10109.31 C10203.00-C10209.31 C10303.00-C10309.31	C10003-C10009 C10103-C10109 C10203-C10209 C10303-C10309		Double Word Device ^{*2*3}
	C40000.00-C4007F.31 C40100.00-C4017F.31 C40200.00-C4027F.31 C40300.00-C4037F.31	C40000-C4007F C40100-C4017F C40200-C4027F C40300-C4037F		Double Word Device ^{*2*3}
	C50000.00-C5007F.31 C50100.00-C5017F.31 C50200.00-C5027F.31 C50300.00-C5037F.31	C50000-C5007F C50100-C5017F C50200-C5027F C50300-C5037F		Double Word Device ^{*2}
	C60000.00-C6007F.31 C60100.00-C6017F.31 C60200.00-C6027F.31 C60300.00-C6037F.31	C60000-C6007F C60100-C6017F C60200-C6027F C60300-C6037F		Double Word Device ^{*2}
	C70000.00-C7007F.31 C70100.00-C7017F.31 C70200.00-C7027F.31 C70300.00-C7037F.31	C70000-C7007F C70100-C7017F C70200-C7027F C70300-C7037F		Double Word Device ^{*2}
	C80000.00-C8007F.31 C80100.00-C8017F.31 C80200.00-C8027F.31 C80300.00-C8037F.31	C80000-C8007F C80100-C8017F C80200-C8027F C80300-C8037F		Double Word Device ^{*2}
	C90000.00-C9007F.31 C90100.00-C9017F.31 C90200.00-C9027F.31 C90300.00-C9037F.31	C90000-C9007F C90100-C9017F C90200-C9027F C90300-C9037F		Double Word Device ^{*2}
	CA0000.00-CA007F.31 CA0100.00-CA017F.31 CA0200.00-CA027F.31 CA0300.00-CA037F.31	CA0000-CA007F CA0100-CA017F CA0200-CA027F CA0300-CA037F		Double Word Device ^{*2}
	CB0000.00-CB007F.31 CB0100.00-CB017F.31 CB0200.00-CB027F.31 CB0300.00-CB037F.31	CB0000-CB007F CB0100-CB017F CB0200-CB027F CB0300-CB037F		Double Word Device ^{*2}
	CC0000.00-CC0039.31 CC0100.00-CC0139.31 CC0200.00-CC0239.31 CC0300.00-CC0339.31	CC0000-CC0039 CC0100-CC0139 CC0200-CC0239 CC0300-CC0339		Double Word Device ^{*2*4}

Device	Bit Address	Word Address	32bit	Remarks
Variable Areas	CD0000.00-CD0039.31 CD0100.00-CD0139.31 CD0200.00-CD0239.31 CD0300.00-CD0339.31	CD0000-CD0039 CD0100-CD0139 CD0200-CD0239 CD0300-CD0339	H/L	Double Word Device *2*4
	CE0000.00-CE0039.31 CE0100.00-CE0139.31 CE0200.00-CE0239.31 CE0300.00-CE0339.31	CE0000-CE0039 CE0100-CE0139 CE0200-CE0239 CE0300-CE0339		Double Word Device *2 *4
	CF0000.00-CF0039.31 CF0100.00-CF0139.31 CF0200.00-CF0239.31 CF0300.00-CF0339.31	CF0000-CF0039 CF0100-CF0139 CF0200-CF0239 CF0300-CF0339		Double Word Device *2 *4
	D00000.00-D00039.31 D00100.00-D00139.31 D00200.00-D00239.31 D00300.00-D00339.31	D00000-D00039 D00100-D00139 D00200-D00239 D00300-D00339		Double Word Device *2 *4
	D10000.00-D10039.31 D10100.00-D10139.31 D10200.00-D10239.31 D10300.00-D10339.31	D10000-D10039 D10100-D10139 D10200-D10239 D10300-D10339		Double Word Device *2 *4
	D20000.00-D20039.31 D20100.00-D20139.31 D20200.00-D20239.31 D20300.00-D20339.31	D20000-D20039 D20100-D20139 D20200-D20239 D20300-D20339		Double Word Device *2 *4
	D30000.00-D30039.31 D30100.00-D30139.31 D30200.00-D30239.31 D30300.00-D30339.31	D30000-D30039 D30100-D30139 D30200-D30239 D30300-D30339		Double Word Device *2 *4
Operation command *6	-	A0000-A000D	H/L	Word Device *5 Bi 15

- *1 Available variable area range varies depending on the using Temperature Controller. Refer to the manual of OMRON Temperature Controller for setting.
- *2 When you write the bit address, the Display reads the word address corresponding to that of the External Device first. Then, it changes the target bit address among the word data once read and returns the word data to the External Device. Note that the correct data may not be written if you change the word address value in the ladder program while the Display reads the data of the External Device and returns it to the External Device.
- *3 Write disable
- *4 When writing, switch the setting area of the Temperature Controller to setting area 1.
- *5 Read disable
- *6 When executing the operation command (write), specify the directive code for the device address. Set the related information for the writing value. Set the related information in hexadecimal number, such as 0x00, 0x01. Set the device code to be used in the painting software as A, and enter each command code instead of the device address.

■ Command code list

Command code	Related information		Command comment	Device address
	Higher byte	Lower byte		
00	0*1	0: OFF (Disabled) 1: ON (Enabled)	Communication writing	A0000

continued to next page

Command code	Related information		Command comment	Device address
	Higher byte	Lower byte		
01	0 to 3, F *2	0: Run 1: Stop	Run/Stop	A0001
02	0 to 3, F *2	0 to 7: Bank 0 to 7	Bank switch	A0002
03	0 to 3, F *2	0: Currently selected PIDset No. 1 to 8: PIDset No.	AT execute	A0003
04	0*1	0: Backup mode 1: RAM write mode	Write mode	A0004
05	0*1	0	Save RAM data	A0005
06	0*1	0	Soft reset	A0006
07	0*1	0	Setting area 1 transfer	A0007
08	0*1	0	Protect level transfer	A0008
09	0 to 3, F *2	0: Auto mode 1: Manual mode	Auto/Manual	A0009
0A	0 to 3, F *2	0: Cancel	AT cancel	A000A
0B	0*1	0	Initialize settings	A000B
0C	0 to 3, F *2	0	Cancel latch	A000C
0D	0 to 3, F *2	0: LSP 1: RSP	SP mode	A000D

*1 Operates for all channels.

*2 Specify for every channel. (0: CH1, 1:CH2, 2:CH3, 3:CH4, F:All channels)

A soft reset will not respond. (No service PDU response)

When all channels are specified, only enabled channels will respond and processing will begin from Channel 1.

If an error is detected on any channel, "Operation error" will be defined. When all channels end normally, normal end will be defined.



IMPORTANT • To enable "Use System Area" in the system area setting of GP-Pro EX may cause a malfunction. Do not set "Use System Area".

NOTE • You can set only Read Area Size for the system area available to use in the Temperature Controller. Please refer to the GP-Pro EX Reference Manual for Read Area Size.
Cf. GP-Pro EX Reference Manual "LS Area (Direct Access Method Area)"

- Please refer to the precautions on manual notation for icons in the table.
☞ "Manual Symbols and Terminology"
- Even if you use the nonexistent address, read error may not be displayed. In this case, "0" is retained for the read data. Note that the writing error is displayed.

6.4 In-Panel NEO

 This address can be specified as system data area.

Device	Bit Address	Word Address	32bit	Remarks
Variable Areas*1	C00000.00-C00006.31 C00100.00-C00106.31	C00000-C00006 C00100-C00106		Double Word Device *2*3
	C10000.00-C10019.31 C10100.00-C10119.31	C10000-C10019 C10100-C10119		Double Word Device *2
	C30000.00-C3003E.31 C30100.00-C3013E.31	C30000-C3003E C30100-C3013E		Double Word Device *2 *4
	C50000.00-C50000.31 C50100.00-C50100.31	C50000 C50100		Double Word Device *2
	C70000.00-C70001.31 C70100.00-C70101.31	C70000-C70001 C70100-C70101		Double Word Device *2*4
Operation command *6	-	A0000-A000C		Word Device *5 

- *1 Available variable area range varies depending on the using Temperature Controller. Refer to the manual of OMRON Temperature Controller for setting.
- *2 When you write the bit address, the Display reads the word address corresponding to that of the External Device first. Then, it changes the target bit address among the word data once read and returns the word data to the External Device. Note that the correct data may not be written if you change the word address value in the ladder program while the Display reads the data of the External Device and returns it to the External Device.
- *3 Write disable
- *4 When writing, switch the setting area of the Temperature Controller to setting area 1.
- *5 Read disable
- *6 When executing the operation command (write), specify the directive code for the device address. Set the related information for the writing value. Set the related information in hexadecimal number, such as 0x00, 0x01. Set the device code to be used in the painting software as A, and enter each command code instead of the device address.

■ Command code list

Command code	Related information * 2	Command comment	Device address
00	“00” or “10”:OFF(disabled) “01” or “11”:ON(enabled)	Communication writing	A0000
01	“00”: Run CH1 “01”: StopCH1 “10”: Run CH2 “11”: Stop CH2 “F0”: Run CH1, CH2*1 “F1”: Stop CH1, CH2*1	Run/Stop	A0001
02	“00”: Select target value 0 for CH1 “01”: Select target value 1 for CH1 “10”: Select target value 0 for CH2 “11”: Select target value 1 for CH2 “F0”: Select target value 0 for CH1, CH2*1 “F1”: Select target value 1 for CH1, CH2*1	Multi-SP	A0002

continued to next page

Command code	Related information * 2	Command comment	Device address
03	"00": Cancel CH1 AT "01": Execute CH1 AT "10": Cancel CH2 AT "11": Execute CH2 AT "F0": Cancel CH1, CH2 AT*1 "F1": Execute CH1, CH2 AT*1	ATexecute/cancel	A0003
04	"00" or "10": Backup "01" or "11": RAM	Write mode	A0004
05	"00" or "10"	Save RAM data	A0005
06	"00" or "10"	Soft reset	A0006
07	"00" or "10"	Setting area 1 transfer	A0007
08	"00" or "10"	Protect level transfer	A0008
09	"00": Auto for CH1 "01": Manual for CH1 "10": Auto for CH2 "11": Manual for CH2 "F0": Auto for CH1, CH2*1 "F1": Manual for CH1, CH2*1	Auto/Manual	A0009
0A	"00" or "10"	PV hold	A000A
0B	"00" or "10"	Initialize settings	A000B
0C	"00": Cancel alarm latch for CH1*1 "01": Cancel alarm latch 2 for CH1*1 "02": Cancel alarm latch 3 for CH1*1 "0F": Cancel all alarm latches for CH1*1 "10": Cancel alarm latch for CH2*1 "11": Cancel alarm latch 2 for CH2*1 "12": Cancel alarm latch 3 for CH2*1 "1F": Cancel all alarm latches for CH2*1 "F0": Cancel alarm latch for CH1, CH2*1 "F1": Cancel alarm latch 2 for CH1, CH2*1 "F2": Cancel alarm latch 3 for CH1, CH2*1 "FF": Cancel all alarm latches for CH2*1	Cancel alarm latch	A000C

*1 Upgraded pulse output models and analog output models can support these commands.

*2 Command codes for which the related information is indicated as "00" or "10" or "01" or "11" use the same command for both CH1 and CH2. You can use either value in the related information. (The result will be the same.)

IMPORTANT

- To enable "Use System Area" in the system area setting of GP-Pro EX may cause a malfunction. Do not set "Use System Area".

NOTE



- You can set only Read Area Size for the system area available to use in the Temperature Controller. Please refer to the GP-Pro EX Reference Manual for Read Area Size.
Cf. GP-Pro EX Reference Manual "LS Area (Direct Access Method Area)"
- Please refer to the precautions on manual notation for icons in the table.

 "Manual Symbols and Terminology"

- Even if you use the nonexistent address, read error may not be displayed. In this case, "0" is retained for the read data. Note that the writing error is displayed.

6.5 THERMAC (E5AC/E5EC/E5CC/E5DC/E5GC)

 This address can be specified as system data area.

Device	Bit Address	Word Address	32bit	Remarks
Variable Areas*1	C00000.00-C00013.31	C00000-C00013		Double Word Device*2*3
	C10000.00-C104DC.31	C10000-C1004D		Double Word Device*2
	C30000.00-C300CB.31	C30000-C300CB		Double Word Device*4
Operation command*6	-	A0000-A0011		Word Device*5 

- *1 Available variable area range varies depending on the using Temperature Controller. Refer to the manual of OMRON Temperature Controller for setting.
- *2 When you write the bit address, the Display reads the word address corresponding to that of the External Device first. Then, it changes the target bit address among the word data once read and returns the word data to the External Device. Note that the correct data may not be written if you change the word address value in the ladder program while the Display reads the data of the External Device and returns it to the External Device.
- *3 Write disable
- *4 When writing, switch the setting area of the Temperature Controller to setting area 1.
- *5 Read disable
- *6 When executing the operation command (write), specify the directive code for the device address. Set the related information for the writing value. Set the related information in hexadecimal number, such as 0x00, 0x01. Set the device code to be used in the painting software as A, and enter each command code instead of the device address.

■ Command code list

Command code	Related information	Command comment	Device address
00	00: OFF (disabled) 01: ON (enabled)	Communications writing	A0000
01	00: Run 01: Stop	RUN/STOP	A0001
02	00: Set point 0 01: Set point 1 02: Set point 2 03: Set point 3	Multi-SP	A0002
03	00: AT Cancel 01: 100% AT execute 02: 40% AT execute	AT Execute/Cancel	A0003
04	00: Backup 01: RAM write mode	Write Mode	A0004
05	00	Save RAM data	A0005
06	00	Software Reset	A0006
07	00	Move to Setup Area 1	A0007
08	00	Move to Protect Level	A0008
09	00: Automatic mode 01: Manual mode	Auto/Manual Switch	A0009
0B	00	Parameter Initialization	A000B

Command code	Related information	Command comment	Device address
0C	00: Alarm 1 latch cancel 01: Alarm 2 latch cancel 02: Alarm 3 latch cancel 03: HB alarm latch cancel 04: HS alarm latch cancel 05: Alarm 4 latch cancel 0F: All alarm latch cancel	Alarm Latch Cancel	A000C
0D	00: Local SP mode 01: Remote SP mode	SP Mode	A000D
0E	00: Not invert 01: Invert	Invert Direct/Reverse Operation	A000E
11	00: Reset 01: Start	Program start	A0011

IMPORTANT



- To enable "Use System Area" in the system area setting of GP-Pro EX may cause a malfunction. Do not set "Use System Area".

NOTE

- You can set only Read Area Size for the system area available to use in the Temperature Controller. Please refer to the GP-Pro EX Reference Manual for Read Area Size.
Cf. GP-Pro EX Reference Manual "LS Area (Direct Access Method Area)"
- Please refer to the precautions on manual notation for icons in the table.
☞ "Manual Symbols and Terminology"
- Even if you use the nonexistent address, read error may not be displayed. In this case, "0" is retained for the read data. Note that the writing error is displayed.

6.6 THERMAC (E5AC-T/E5EC-T/E5CC-T)

 This address can be specified as system data area.

Device	Bit Address	Word Address	32bit	Remarks
Variable Areas*1	C00000.00-C0001C.31	C00000-C0001C		Double Word Device*2*3
	C10000.00-C10051.31	C10000-C10051		Double Word Device*2
	C30000.00-C300C9.31	C30000-C300C9		Double Word Device*2*4
	C40000.00-C4001B.31	C40000-C4001B		Double Word Device*2
	C50000.00-C5007C.31	C50000-C5007C		Double Word Device*2
	C90000.00-C90041.31	C90000-C90041		Double Word Device*2*4
	DA0000.00-DA0795.31	DA0000-DA0795		Double Word Device*2
Operation command*6	-	A0000-A0014		Word Device*5 

- *1 Available variable area range varies depending on the using Temperature Controller. Refer to the manual of OMRON Temperature Controller for setting.
- *2 When you write the bit address, the Display reads the word address corresponding to that of the External Device first. Then, it changes the target bit address among the word data once read and returns the word data to the External Device. Note that the correct data may not be written if you change the word address value in the ladder program while the Display reads the data of the External Device and returns it to the External Device.
- *3 Write disable
- *4 When writing, switch the setting area of the Temperature Controller to setting area 1.
- *5 Read disable
- *6 When executing the operation command (write), specify the directive code for the device address. Set the related information for the writing value. Set the related information in hexadecimal number, such as 0x00, 0x01. Set the device code to be used in the painting software as A, and enter each command code instead of the device address.

■ Command code list

Command code	Related information	Command comment	Device address
00	00: OFF (disabled) 01: ON (enabled)	Communications writing	A0000
01	00: Run 01: RESET	RUN/RESET	A0001
03	0E: All PID 40% AT Execute 0F: All PID 100% AT Execute 00: AT cancel 01: 100% AT execute 02: 40% AT execute	AT Execute/Cancel	A0003
04	00: Backup 01: RAM write mode	Write Mode	A0004
05	00	Save RAM data	A0005
06	00	Software reset	A0006
07	00	Move to Setup Area 1	A0007
08	00	Move to Protect Level	A0008
09	00: Automatic mode 01: Manual mode	Auto/Manual Switch	A0009
0B	00	Parameter Initialization	A000B

Command code	Related information	Command comment	Device address
0C	00: Alarm 1 latch cancel 01: Alarm 2 latch cancel 02: Alarm 3 latch cancel 03: HB alarm latch cancel 04: HS alarm latch cancel 05: Alarm 4 latch cancel 0F: All alarm latch cancel	Alarm Latch Cancel	A000C
0D	00: Program SP mode 01: Fixed SP mode	SP Mode	A000D
0E	00: Not invert 01: Invert	Invert Direct/Reverse Operation	A000E
13	00:Clear hold 01:Hold	Hold	A0013
14	00	Advance	A0014

IMPORTANT

- To enable "Use System Area" in the system area setting of GP-Pro EX may cause a malfunction. Do not set "Use System Area".

NOTE

- You can set only Read Area Size for the system area available to use in the Temperature Controller. Please refer to the GP-Pro EX Reference Manual for Read Area Size.
Cf. GP-Pro EX Reference Manual "LS Area (Direct Access Method Area)"
- Please refer to the precautions on manual notation for icons in the table.
 "Manual Symbols and Terminology"
- Even if you use the nonexistent address, read error may not be displayed. In this case, "0" is retained for the read data. Note that the writing error is displayed.

6.7 THERMAC (E5ED/E5CD)

 This address can be specified as system data area.

Device	Bit Address	Word Address	32bit	Remarks
Variable Areas*1	C00000.00-C0001E.31	C00000-C0001E	H/L	Double Word Device*2*3
	C10000.00-C1005C.31	C10000-C1005C		Double Word Device*2
	C30000.00-C300DF.31	C30000-C300DF		Double Word Device*2*4
Operation command*6	-	A0000-A0012		Word Device*5 Bit 15

- *1 Available variable area range varies depending on the using Temperature Controller. Refer to the manual of OMRON Temperature Controller for setting.
- *2 When you write the bit address, the Display reads the word address corresponding to that of the External Device first. Then, it changes the target bit address among the word data once read and returns the word data to the External Device. Note that the correct data may not be written if you change the word address value in the ladder program while the Display reads the data of the External Device and returns it to the External Device.
- *3 Write disable
- *4 When writing, switch the setting area of the Temperature Controller to setting area 1.
- *5 Read disable
- *6 When executing the operation command (write), specify the directive code for the device address. Set the related information for the writing value. Set the related information in hexadecimal number, such as 0x00, 0x01. Set the device code to be used in the painting software as A, and enter each command code instead of the device address.

■ Command code list

Command code	Related information	Command comment	Device address
00	00: OFF (disabled) 01: ON (enabled)	Communications writing	A0000
01	00: Run 01: Stop	RUN/STOP	A0001
02	00: Set point 0 01: Set point 1 02: Set point 2 03: Set point 3 04: Set point 4 05: Set point 5 06: Set point 6 07: Set point 7	Multi-SP	A0002
03	00: AT cancel 01: 100% AT execute 02: 40% AT execute	AT Execute/Cancel	A0003
04	00: Backup 01: RAM write mode	Write Mode	A0004
05	00	Save RAM Data	A0005
06	00	Software Reset	A0006
07	00	Move to Setup Area 1	A0007
08	00	Move to Protect Level	A0008
09	00: Automatic mode 01: Manual mode	Auto/Manual Switch	A0009

Command code	Related information	Command comment	Device address
0B	00	Parameter Initialization	A000B
0C	00: Alarm 1 latch cancel 01: Alarm 2 latch cancel 02: Alarm 3 latch cancel 03: HB alarm latch cancel 04: HS alarm latch cancel 05: Alarm 4 latch cancel 0F: All alarm latch cancel	Alarm Latch Cancel	A000C
0D	00: Local SP mode 01: Remote SP mode	SP Mode	A000D
0E	00: Not invert 01: Invert	Invert Direct/Reverse Operation	A000E
0F	00	PID Update (Adaptive Control)	A000F
11	00: Reset 01: Start	Program Start	A0011
12	00: OFF 01: ON	Automatic Filter Adjustment	A0012

IMPORTANT

- To enable "Use System Area" in the system area setting of GP-Pro EX may cause a malfunction. Do not set "Use System Area".

NOTE

- You can set only Read Area Size for the system area available to use in the Temperature Controller. Please refer to the GP-Pro EX Reference Manual for Read Area Size.
Cf. GP-Pro EX Reference Manual "LS Area (Direct Access Method Area)"
- Please refer to the precautions on manual notation for icons in the table.
 "Manual Symbols and Terminology"
- Even if you use the nonexistent address, read error may not be displayed. In this case, "0" is retained for the read data. Note that the writing error is displayed.

7 Device Code and Address Code

Use device code and address code when you select "Device & Address" for the address type in data displays.

7.1 THERMAC NEO (E5AN/E5EN/E5CN/E5GN)

Device	Device Name	Device Code (HEX)	Address Code
Variable Areas	C0	0080	Word Address
	C1	0081	Word Address
	C3	0082	Word Address
Operation command	A	0000	Word Address

7.2 THERMAC NEO (E5AN-H/E5EN-H/E5CN-H)

Device	Device Name	Device Code (HEX)	Address Code
Variable Areas	C0	0080	Word Address
	C1	0081	Word Address
	C3	0082	Word Address
	C4	0083	Word Address
	C5	0084	Word Address
Operation command	A	0000	Word Address

7.3 THERMAC R (E5AR/E5ER)

Device	Device Name	Device Code (HEX)	Address Code
Variable Areas	C0	0080	Word Address
	C1	0081	Word Address
	C4	0083	Word Address
	C5	0084	Word Address
	C6	0085	Word Address
	C7	0086	Word Address
	C8	0087	Word Address
	C9	0088	Word Address
	CA	0089	Word Address
	CB	008A	Word Address
	CC	008B	Word Address
	CD	008C	Word Address
	CE	008D	Word Address
	CF	008E	Word Address
	D0	008F	Word Address
	D1	0090	Word Address
	D2	0091	Word Address
D3	0092	Word Address	
Operation command	A	0000	Word Address

7.4 In-Panel NEO

Device	Device Name	Device Code (HEX)	Address Code
Variable Areas	C0	0080	Word Address
	C1	0081	Word Address
	C3	0082	Word Address
	C5	0084	Word Address
	C7	0086	Word Address
Operation command	A	0000	Word Address

7.5 THERMAC (E5AC/E5EC/E5CC/E5DC/E5GC)

Device	Device Name	Device Code (HEX)	Address Code
Variable Areas	C0	0080	Word Address
	C1	0081	Word Address
	C3	0082	Word Address
Operation command	A	0000	Word Address

7.6 THERMAC (E5AC-T/E5EC-T/E5CC-T)

Device	Device Name	Device Code (HEX)	Address Code
Variable Areas	C0	0080	Word Address
	C1	0081	Word Address
	C3	0082	Word Address
	C4	0083	Word Address
	C5	0084	Word Address
	C9	0088	Word Address
	DA	0093	Word Address
Operation command	A	0000	Word Address

7.7 THERMAC (E5ED/E5CD)

Device	Device Name	Device Code (HEX)	Address Code
Variable Areas	C0	0080	Word Address
	C1	0081	Word Address
	C3	0082	Word Address
Operation command	A	0000	Word Address

8 Error Messages

Error messages are displayed on the screen of Display as follows: "No. : Device Name: Error Message(Error Occurrence Area)". Each description is shown below.

Item	Description
No.	Error No.
Device Name	Name of External Device where error occurs. Name of External Device is a title of External Device set with GP-Pro EX.((Initial value[PLC1])
Error Message	Displays messages related to the error which occurs.
Error Occurrence Area	<p>Displays IP address or device address of External Device where error occurs, or error codes received from External Device.</p> <p>NOTE</p> <ul style="list-style-type: none"> • IP address is displayed such as "IP address(Decimal): MAC address (Hex)". • Device address is displayed such as "Address: Device address". • Received error codes are displayed such as "Decimal[Hex]".

Display Examples of Error Messages

"RHAA035: PLC1: Error has been responded for device write command (Error Code: 2[02H])"

-
- NOTE**
- Refer to your External Device manual for details on received error codes.
 - Refer to "Display-related errors" in "Maintenance/Troubleshooting Guide" for details on the error messages common to the driver.
-