

# FP6000 Series

## User Manual

FP6000-MM01-EN\_00

10/2021

# Legal Information

The Pro-face brand and any trademarks of Schneider Electric SE and its subsidiaries referred to in this guide are the property of Schneider Electric SE or its subsidiaries. All other brands may be trademarks of their respective owners.

This guide and its content are protected under applicable copyright laws and furnished for informational use only. No part of this guide may be reproduced or transmitted in any form or by any means (electronic, mechanical, photocopying, recording, or otherwise), for any purpose, without the prior written permission of Schneider Electric.

Schneider Electric does not grant any right or license for commercial use of the guide or its content, except for a non-exclusive and personal license to consult it on an "as is" basis. Schneider Electric products and equipment should be installed, operated, serviced, and maintained only by qualified personnel.

As standards, specifications, and designs change from time to time, information contained in this guide may be subject to change without notice.

To the extent permitted by applicable law, no responsibility or liability is assumed by Schneider Electric and its subsidiaries for any errors or omissions in the informational content of this material or consequences arising out of or resulting from the use of the information contained herein.

---

# Table of Contents

Safety Information .....	5
About This Manual.....	6
Document Scope .....	6
Validity Note .....	6
Registered Trademarks .....	6
Related Documents .....	6
Product Related Information .....	6
Overview .....	11
Model Numbers .....	11
Package Contents .....	11
Certifications and Standards .....	12
Federal Communication Commission Radio Frequency Interference Statement - For USA .....	13
Hazardous Location Installation - For USA and Canada .....	14
Device Connectivity .....	16
System Design .....	16
Accessories.....	17
Maintenance Accessories .....	18
Parts Identification and Functions .....	19
Parts Identification .....	20
LED Indications .....	21
Specifications.....	22
General Specifications .....	22
Electrical Specifications .....	22
Environmental Specifications .....	22
Structural Specifications .....	23
Functional Specifications.....	26
Display Specifications.....	26
Touch Panel.....	27
Interface Specifications .....	27
Specifications of Each Interface .....	27
Interface Connection .....	27
DVI-D Input Interface.....	30
Dimensions.....	33
External Dimensions (FP-6600TM) .....	33
External Dimensions (FP-6700TM) .....	34
External Dimensions (FP-6500WC).....	34
External Dimensions (FP-6600WC).....	35
External Dimensions (FP-6700WC).....	36
External Dimensions (FP-6800WC).....	36
External Dimensions (FP-6900WC).....	37
Installation Fastener.....	37
External Dimensions .....	37
Installation and Wiring.....	38
Installation.....	38
Precautions for Building into an End-use Product.....	38
Installation Requirements .....	39
Panel Cut Dimensions .....	40

---

Installation Procedure.....	41
Removal Procedure.....	43
Wiring the Power Supply .....	44
DC Power Cord Preparation.....	44
Connecting the DC Power Cord.....	45
Power Supply Precautions .....	46
Grounding .....	48
USB Cable Clamp.....	49
Attaching USB Clamp Type B.....	49
Front USB Cover .....	51
Maintenance .....	53
Regular Cleaning .....	53
Periodic Check Points .....	53
Replacing the Installation Gasket .....	54
Replacing the Backlight.....	54
After-sales Service .....	54
System Specification and Launcher .....	55
System Specifications .....	55
Settings Workflow .....	55
Launcher.....	56
Starting the Launcher .....	56
Buzzer.....	57
Brightness .....	58
Calibration .....	59
Front USB .....	61
Touch Mode.....	62
FP6 System.....	63
Edit .....	64

# Safety Information

## Important Information

Read these instructions carefully, and look at the equipment to become familiar with the device before trying to install, operate, service, or maintain it. The following special messages may appear throughout this documentation or on the equipment to warn of potential hazards or to call attention to information that clarifies or simplifies a procedure.



The addition of this symbol to a "Danger" or "Warning" safety label indicates that an electrical hazard exists which will result in personal injury if the instructions are not followed.



This is the safety alert symbol. It is used to alert you to potential personal injury hazards. Obey all safety messages that follow this symbol to avoid possible injury or death.

### **DANGER**

**DANGER** indicates a hazardous situation which, if not avoided, **will result in** death or serious injury.

### **WARNING**

**WARNING** indicates a hazardous situation which, if not avoided, **could result in** death or serious injury.

### **CAUTION**

**CAUTION** indicates a hazardous situation which, if not avoided, **could result in** minor or moderate injury.

### **NOTICE**

**NOTICE** is used to address practices not related to physical injury.

## Please Note

Electrical equipment should be installed, operated, serviced, and maintained only by qualified personnel. No responsibility is assumed by Schneider Electric for any consequences arising out of the use of this material.

A qualified person is one who has skills and knowledge related to the construction and operation of electrical equipment and its installation, and has received safety training to recognize and avoid the hazards involved.

# About This Manual

## Document Scope

This manual describes how to use this product.

## Validity Note

This documentation is valid for this product.

The technical characteristics of the device(s) described in the present manual also appear online at [www.pro-face.com](http://www.pro-face.com).

The characteristics that are described in the present document should be the same as those characteristics that appear online. In line with our policy of constant improvement, we may revise content over time to improve clarity and accuracy. If you see a difference between the document and online information, use the online information as your reference.

## Registered Trademarks

Microsoft® and Windows® are registered trademarks of Microsoft Corporation in the United States and/or other countries.

Product names used in this manual may be the registered trademarks owned by the respective proprietors.

## Related Documents

You can download the manuals related to this product, such as the software manual, from our website.

<https://www.pro-face.com/trans/en/manual/1085.html>

## Product Related Information

If the equipment is used in a manner not specified by the manufacturer, the protection provided by the equipment may be impaired.

**⚠️ DANGER****HAZARD OF ELECTRIC SHOCK, EXPLOSION, OR ARC FLASH**

- Remove all power from the device before removing any covers or elements of the system, and prior to installing or removing any accessories, hardware, or cables.
- Unplug the power cable from both this product and the power supply prior to installing or removing the product.
- Always use a properly rated voltage sensing device to confirm power is off where and when indicated.
- Replace and secure all covers or elements of the system before applying power to this product.
- Use only the specified voltage when operating this product. This product is designed to use 24 Vdc. Always check whether your device is DC powered before applying power.
- When using this product in Class I, Division 2, Groups A, B, C, and D hazardous locations, install this product in an enclosure that prevents the operator from touching the back of this product without the use of tools.

**Failure to follow these instructions will result in death or serious injury.**

Critical alarm indicators and system functions require independent and redundant protection hardware and/or mechanical interlocks.

When you cycle power, wait at least 10 seconds after it has been turned off. If this product is restarted too quickly, it may not operate correctly.

In the event the screen cannot be properly read, for example, if the backlight is not functioning, it may be difficult or impossible to identify a function. Functions that may present a hazard if not immediately executed, such as a fuel shut-off, must be provided independently of this product. The machine's control system design must take into account the possibility of the backlight no longer functioning and the operator being unable to control the machine or making mistakes in the control of the machine.

**⚠️ WARNING****LOSS OF CONTROL**

- The designer of any control scheme must consider the potential failure modes of control paths and, for certain critical control functions, provide a means to achieve a safe state during and after a path failure. Examples of critical control functions are emergency stop and overtravel stop, power outage and restart.
- Separate or redundant control paths must be provided for critical control functions.
- System control paths may include communication links. Consideration must be given to the implications of unanticipated transmission delays or failures of the link.
- Observe all accident prevention regulations and local safety guidelines.
- Each implementation of this product must be individually and thoroughly tested for proper operation before being placed into service.
- The machine control system design must take into account the possibility of the backlight no longer functioning and the operator being unable to control the machine, or making errors in the control of the machine.

**Failure to follow these instructions can result in death, serious injury, or equipment damage.**

For additional information, refer to NEMA ICS 1.1 (latest edition), "Safety Guidelines for the Application, Installation, and Maintenance of Solid State Control" and to NEMA ICS 7.1 (latest edition), "Safety Standards for Construction and Guide for Selection, Installation and Operation of Adjustable-Speed Drive Systems" or their equivalent governing your particular location.

**⚠ WARNING****UNINTENDED EQUIPMENT OPERATION**

- The application of this product requires expertise in the design and programming of control systems. Only persons with such expertise should be allowed to program, install, alter, and apply this product.
- Follow all local and national safety standards.

**Failure to follow these instructions can result in death, serious injury, or equipment damage.**

**⚠ WARNING****UNINTENDED EQUIPMENT OPERATION**

- Do not use this product as the only means of control for critical system functions such as motor start/stop or power control.
- Do not use this equipment as the only notification device for critical alarms, such as device overheating or overcurrent.
- Use only the software provided with this product. If you use other software, please confirm the operation and safety before use.

**Failure to follow these instructions can result in death, serious injury, or equipment damage.**

The following characteristics are specific to the LCD panel and are considered normal behavior:

- LCD screen may show unevenness in the brightness of certain images or may appear different when seen from outside the specified viewing angle. Extended shadows, or crosstalk may also appear on the sides of screen images.
- LCD screen pixels may contain black and white colored spots and color display may seem to have changed.
- When experiencing vibrations within a certain frequency range and vibration acceleration is above what is acceptable, the LCD screen may partially turn white. Once the vibration condition ends, the whitening of the screen is resolved.
- When the same image is displayed on the screen for a long period, an afterimage may appear when the image is changed.
- The panel brightness may decrease when used for a long time in an environment continuously filled with inert gas. To prevent deterioration of panel brightness, regularly ventilate the panel. For more information, please contact customer support.

<https://www.pro-face.com/trans/en/manual/1015.html>

**NOTE:** Change the screen image periodically and try not to display the same image for a long period of time.



**▲ WARNING****SERIOUS EYE AND SKIN INJURY**

The liquid in the LCD panel contains an irritant:

- Avoid direct skin contact with the liquid.
- Wear gloves when you handle a broken or leaking unit.
- Do not use sharp objects or tools in the vicinity of the LCD panel.
- Handle the LCD panel carefully to prevent puncture, bursting, or cracking of the panel material.
- If the panel is damaged and any liquid comes in contact with your skin, immediately rinse the area with running water for at least 15 minutes. If the liquid gets in your eyes, immediately rinse your eyes with running water for at least 15 minutes and consult a doctor.

**Failure to follow these instructions can result in death, serious injury, or equipment damage.**

**Precautions on using models with projected capacitive touch panel**

Models with a projected capacitive touch panel may operate abnormally when the display surface is wet.

**▲ WARNING****LOSS OF CONTROL**

- Do not touch the touch panel area during operating system startup.
- Do not operate when the touch panel surface is wet.
- If the touch panel surface is wet, remove any excess water with a soft cloth before operation.

**Failure to follow these instructions can result in death, serious injury, or equipment damage.**

**NOTE:**

- If **Touch Mode** is set to **Water detection mode**, when an abnormal touch (such as water) occurs, touch is disabled for a few seconds to avoid accidental touch. Normal touch operation recovers a few seconds after the abnormal touch condition is removed. For information about Touch Mode, refer to [Touch Mode](#), page 62.
- While the system is starting up, as the touch panel initial values are being checked, do not touch the touch panel area.

**NOTICE****EQUIPMENT DAMAGE**

- Do not press on the display of this product with excessive force or with a hard object.
- Do not press on the touch panel with a pointed object, such as the tip of a mechanical pencil or a screwdriver.
- Handle this product carefully to prevent puncture, bursting, or cracking of the panel material.

**Failure to follow these instructions can result in equipment damage.**

Compared to conventional analog resistive film, projected capacitive touch panels have higher transmittance and lighter touch operation, as well as supporting multi-touch. As it is able to detect weak changes in capacitance, projected capacitive touch panels are susceptible to environmental noise.

While our products have been optimized for industrial environmental noise and conform to CE marking, our products cannot support all environmental noise.

Please consider the following in the installation environment to avoid touch malfunction.

Example:

To reduce the noise voltage of the enclosure of the equipment housing this product:

- Implement noise countermeasures in the equipment. For example, install a noise filter on the inverter, servo amplifier, or other equipment. Refer to the manufacturer's instruction manual.
- Attach a ground wire noise filter to the FG connection of equipment.
- Connect the enclosure for the equipment to the building. For example, connect to the concrete or steel reinforcement parts of the building.

**NOTE:** If there is a lot of environmental noise, because the noise filter for the touch panel controller has to run, touch response may become slow.

## Cybersecurity Best Practices

To help keep your Pro-face products secure and protected, we recommend that you implement the cybersecurity best practices. Following the recommendations may help significantly reduce your company's cybersecurity risk. For the recommendations, refer to the following URL:

<https://www.pro-face.com/trans/en/manual/1087.html>

# Overview

## What's in This Chapter

Model Numbers..... 11  
 Package Contents..... 11  
 Certifications and Standards ..... 12  
 Federal Communication Commission Radio Frequency Interference  
 Statement - For USA ..... 13  
 Hazardous Location Installation - For USA and Canada ..... 14

## Model Numbers

### Model List

Series	Model name	Model number
FP6000 Series	FP-6600TM	PFXFP6600TMD
	FP-6700TM	PFXFP6700TMD
	FP-6500WC	PFXFP6500WCD
	FP-6600WC	PFXFP6600WCD
	FP-6700WC	PFXFP6700WCD
	FP-6800WC	PFXFP6800WCD
	FP-6900WC	PFXFP6900WCD

**NOTE:** All model numbers may be followed by any letter or number.

### Model Number Configuration

The following describes the configuration of model numbers.

Digit position								
1	2	3	4	5	6	7	8	9
P	F	X	(model)		(series)	(display size)		(type)
			FP		6	5: 10" 6: 12" 7: 15" 8: 19" 9: 22"		00: Standard

10	11	12
(LCD)	(touch panel)	(power supply)
T: 4:3 TFT W: Wide TFT	M: Analog multi touch C: Capacitive multi touch	D: DC

### Global Code

A global code is assigned to every Pro-face product as a universal model number. For more information on product models and their matching global codes, please refer to the following URL.

<https://www.pro-face.com/trans/en/manual/1003.html>

## Package Contents

Verify all items listed here are present in your package.

**NOTE:** This product has been carefully packed with special attention to quality. However, should you find anything damaged or missing, please contact customer support immediately.

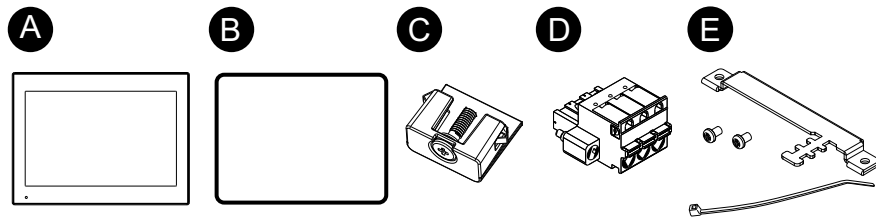

- A. FP6000 Series: 1
- B. Installation gasket: 1 (attached to the product)
- C. Installation fasteners (attached to the product):
  - 4 pieces (for FP-6600TM, FP-6500WC and FP-6600WC)
  - 8 pieces (for FP-6700TM, FP-6700WC, FP-6800WC and FP-6900WC)
- D. DC power connector: 1
- E. USB clamp (Type B): 1 set (1 bracket, 2 screws and 1 tie)
- F. Warning/Caution Information: 1

## Product Revision and QR Code for Manual

You can identify the product version (PV) from the product label.

You can also check the contents of this manual by using the QR code on the product label. Confirm the location of the QR code below and refer to the manual.

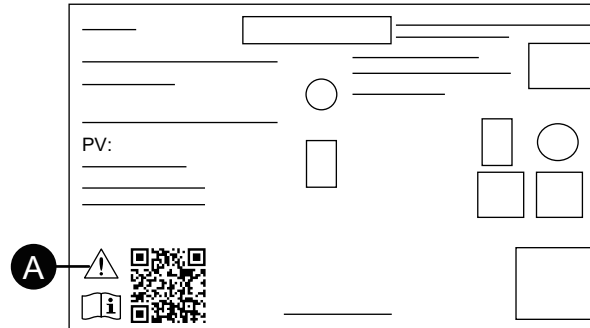

- A. This mark indicates that you can refer to this manual by using the QR code, and that you must use copper wire rated for 75 °C (167 °F) or higher. Refer to *Wiring the Power Supply*, page 44.

## Certifications and Standards

The certifications and standards listed below may include those that are not yet acquired. Please check the product marking and the following URL for the latest acquisition status.

<https://www.pro-face.com/trans/en/manual/1002.html>

### Agency Certifications

- Underwriters Laboratories Inc., UL 61010-2-201 and CSA C22.2 N°61010-2-201, for Industrial Control Equipment used in Ordinary Location

- Underwriters Laboratories Inc., UL 121201 and CSA C22.2 N°213, for Industrial Control Equipment used in Class I, Division 2 Hazardous (Classified) Locations
- IECEx / ATEX for use in zone 2 gas /zone 22 dust

### Compliance Standards

Europe:

CE

- Directive 2014/30/EU (EMC)

Australia:

- RCM

Korea:

- KC

### Hazardous Substances

This product is designed to be compliant with the following environmental regulations, even if the product may not fall directly in the scope of the regulation:

- RoHS, Directive 2011/65/EU and 2015/863/EU
- RoHS China, Standard GB/T 26572
- REACH regulation EC 1907/2006

### End of Life (WEEE)

The product contains electronic boards. It must be disposed of in specific treatment channels. The product contains cells and/or storage batteries which must be collected and processed separately when they have run out and at the end of product life (Directive 2012/19/EU).

Refer to [Maintenance](#), page 53 when extracting cells and batteries from the product. These batteries do not contain a weight percentage of heavy metals over the threshold notified by European Directive 2006/66/EC.

### KC Markings

기종별	사용자안내문
A급 기기 (업무용 방송통신기자재)	이 기기는 업무용(A급) 전자파적합기기로서 판매자 또는 사용자는 이 점을 주의하시기 바라며, 가정외의 지역에서 사용하는 것을 목적으로 합니다.

## Federal Communication Commission Radio Frequency Interference Statement - For USA

### FCC Radio Interference Information

This product has been tested and found to comply with the Federal Communications Commission (FCC) limits for a Class A digital device, pursuant to Part 15 of the FCC Rules. These limits are designed to provide reasonable protection against harmful interference in a commercial, industrial or business environment. This product generates, uses, and can radiate radio frequency

energy and, if not installed and used in accordance with the instructions, may cause or be subject to interference with radio communications. To minimize the possibility of electromagnetic interference in your application, observe the following two rules:

- Install and operate this product in such a manner that it does not radiate sufficient electromagnetic energy to cause interference in nearby devices.
- Install and test this product to ensure that the electromagnetic energy generated by nearby devices does not interfere with the operation of this product.
- Changes or modifications not expressly approved by the party responsible for compliance could void the user's authority to operate this product.

## **⚠ WARNING**

### **ELECTROMAGNETIC / RADIO INTERFERENCE**

Electromagnetic radiation may disrupt the operation of this product leading to unintended equipment operation. If electromagnetic interference is detected:

- Increase the distance between this product and the interfering equipment.
- Reorient this product and the interfering equipment.
- Reroute power and communication lines to this product and the interfering equipment.
- Connect this product and the interfering equipment to different power supplies.
- Always use shielded cables when connecting this product to a peripheral device or another computer.

**Failure to follow these instructions can result in death, serious injury, or equipment damage.**

## Hazardous Location Installation - For USA and Canada

### General

This product is suitable for use in Class I, Division 2, Groups A, B, C, and D hazardous locations or in non-hazardous locations. Before installing or using this product, confirm that the Hazardous Location certification appears on the product labeling.

**NOTE:** Some products are not yet rated as suitable for use in hazardous locations. Always use your product in conformance with the product labeling and this manual.

## **⚡⚠ DANGER**

### **HAZARD OF ELECTRIC SHOCK, EXPLOSION, OR ARC FLASH**

- Remove all power from the device before removing any covers or elements of the system, and prior to installing or removing any accessories, hardware, or cables.
- Unplug the power cable from both this product and the power supply.
- Always use a properly rated voltage sensing device to confirm power is off where and when indicated.
- Replace and secure all covers or elements of the system before applying power to this product.
- Use only the specified voltage when operating this product. This product is designed to use 24 Vdc. Always check whether your device is DC powered before applying power.

**Failure to follow these instructions will result in death or serious injury.**

## ▲ WARNING

### EXPLOSION HAZARD

- Do not use this product in hazardous environments or locations other than Class I, Division 2, Groups A, B, C, and D.
- Substitution of any components may impair suitability for Class I, Division 2.
- Always confirm the UL 121201 or CSA C22.2 N°213 hazardous location rating of your device before installing or using it in a hazardous location.
- To apply or remove the supply power from this product installed in a Class I, Division 2 hazardous location, you must either: A) Use a switch located outside the hazardous environment, or B) Use a switch certified for Class I, Division 1 operation inside the hazardous area.
- Do not connect or disconnect equipment unless power has been switched off or the area is known to be non-hazardous. This applies to all connections including power, ground, serial, parallel, and network connections.
- Do not install any components, equipment, or accessories manufactured by us or by OEM unless these have also been qualified as suitable for use in Class I, Division 2, Groups A, B, C, and D locations.
- Never use unshielded/ungrounded cables in hazardous locations.
- Use only non-incendive USB devices.
- Do not attempt to install, operate, modify, maintain, service, or otherwise alter this product except as permitted in this manual. Unpermitted actions may impair the suitability of this product for Class I, Division 2 operation.

**Failure to follow these instructions can result in death, serious injury, or equipment damage.**

Make sure that this product is properly rated for the location. If the intended location does not presently have a Class, Division and Group rating, then users should consult the appropriate authorities having jurisdiction in order to determine the correct rating for that hazardous location.

## Operation and Maintenance

The systems have been designed for compliance with relevant spark ignition tests.

## ▲ WARNING

### EXPLOSION HAZARD

In addition to the other instructions in this manual, observe the following rules when installing this product in a hazardous location:

- Wire the equipment in accordance with the National Electrical Code article 501.10 (B) for Class I, Division 2 hazardous locations.
- Install this product in an enclosure suitable for the specific application.

**Failure to follow these instructions can result in death, serious injury, or equipment damage.**

**NOTE:** IP65F is not part of UL certification.

# Device Connectivity

## What's in This Chapter

System Design.....	16
Accessories .....	17

## System Design

This product is an industrial PC monitor with a touch panel mounted. This section describes the system configuration with this product and peripheral equipment.

### NOTE:

- Connect both the DVI-D and USB (Type B) interfaces on this product to the host.
- Only the FP-6●00TM has a front USB (Type A) Interface. To be able to use the USB (Type A) interface, you need to connect the USB (Type B) interface to a host with a USB cable.

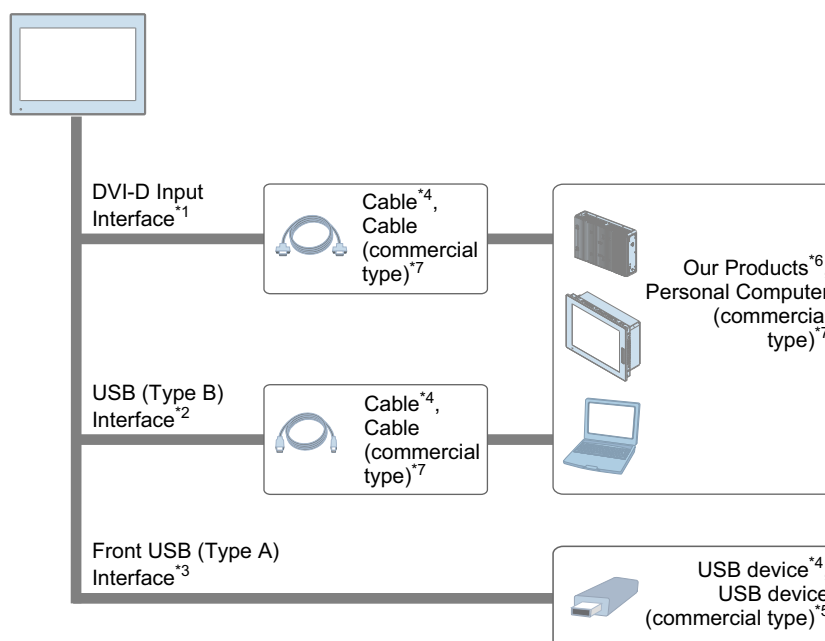

\*1 Receives the image signal from the host.

\*2 Sends touch panel data to the host.

\*3 Only FP-6●00TM.

\*4 Refer to Accessories, page 17.

\*5 For supported models, refer to our support site.  
<https://www.pro-face.com/trans/en/manual/1001.html>

\*6 Refer to our website.  
<https://www.pro-face.com>

\*7 Avoid using hosts or cables that do not conform with the following interface standards. Otherwise, it may not work properly.

DVI: Digital Visual Interface Rev.1.0

DP: VESA DisplayPort Standard Version 1, Revision 3 (DP1.3) or later

HDMI: High-Definition Multimedia Interface Specification Version 1.0 or later

USB: Universal Serial Bus Version 2.0 or later



## Accessories

This section introduces optional products that can be used with this product.

**NOTE:** For host controllers and connection cables, refer to the corresponding device driver manual of your screen editing software.

Product name		Product number	Description
<b>USB (Type B) interface</b>			
USB Cable (5 m)		FP-US00	Cable used for touch panel data transmission between a host (USB Type A) and this product (USB Type B).
<b>DVI-D input interface</b>			
DP-DVI Cable (5 m)* <sup>1</sup>		PFXYFPCBDPDV5M	DP-DVI cable used to receive the image signal from host (5 m)
DP-DVI Cable (3 m)		PFXZPBCBDPDV32	DP-DVI cable used to receive the image signal from host, active type (3 m)
DP-DVI Adapter		PFXZPBADCVDPDV2	DP-DVI Adapter can convert DP to DVI-D (socket), active type.
DVI Cable (5 m)		FP-DV01-50	DVI-D cable used to receive the image signal from host. DVI 1.0 compliant (DVI-D 24-pin plug) (5 m)
<b>Others</b>			
Enhanced Front USB Cover (With Screw)		PFXZCDCVUS1	Front USB cover with fixing screw, corresponding to IP66F, IP67F, Type 1/4X Indoor Use Only/13 or ATEX certifications (5 pieces/set)
Screen Protection Sheet	12-inch	CA7-DFS12-01	Disposable, dirt-resistant sheet for screen (5 sheets/set)
	15-inch	CA3-DFS15-01	
Anti-Glare Sheet	10-inch Wide	PFXZCAG5W1	Prevent reflections, dirt-resistant sheet for screen (5 sheets/set)
	12-inch Wide	PFXZCAG6W1	
	15-inch Wide	PFXZCAG7W1	
	19-inch Wide	PFXZCAG8W1	
	22-inch Wide	PFXZCAG9W1	
Panel Cutout Adapter <sup>2</sup>	12-inch Wide	PFXZPAT6W1	Panel cutout adapter for mounting FP6000 Series/PS6000 Series Panel Type (12-inch wide) in cutout for PS5000 Series (12-inch wide).
	15-inch Wide	PFXZPAT7W1	Panel cutout adapter for mounting FP6000 Series/PS6000 Series Panel Type (15-inch wide) in cutout for PS5000 Series (15-inch wide).
	19-inch Wide	PFXZPAT8W1	Panel cutout adapter for mounting FP6000 Series/PS6000 Series Panel Type (19-inch wide) in cutout for PS5000 Series (19-inch wide).
	22-inch Wide	PFXZPAT9W1	Panel cutout adapter for mounting FP6000 Series/PS6000 Series Panel Type (22-inch wide) in cutout for PS5000 Series (22-inch wide).

\*1 This is a passive cable. The host PC must support DP++ (Display Port Dual mode).

\*2 The range for the allowable panel thickness varies depending on the panel cut adapter. For information, refer to the panel cut adapter instruction manual.

## Maintenance Accessories

Product name		Product number	Description
Installation Gasket	12-inch	PFXZCDWG121	Provides dust and moisture resistance when this product is installed into a solid panel (1 piece)
	15-inch	PFXZCDWG151	
	10-inch Wide	PFXZCDWG102	
	12-inch Wide	PFXZCDWG122	
	15-inch Wide	PFXZCHWG154	
	19-inch Wide	PFXZCWG8W1	
	22-inch Wide	PFXZCWG9W1	
DC Power Supply Connector with fixable screws		CA7-ACCNL-01	Connector to connect DC power supply cables (5 pieces/set)
Installation Fastener		PFXZCAF1	(4 pieces/set)
USB Clamp Type B (1 port)		PFXYFPCLUSB	Clamp to prevent disconnection of USB Type B cable (5 pieces/set)

# Parts Identification and Functions

## What's in This Chapter

Parts Identification.....	20
LED Indications.....	21

# Parts Identification

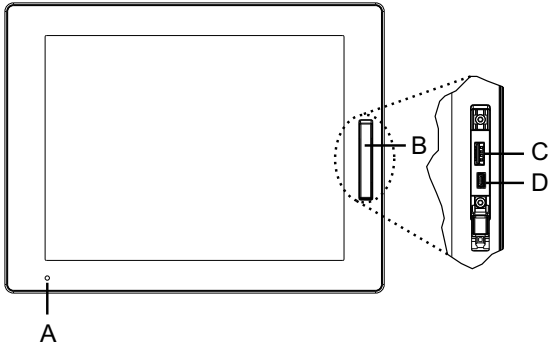
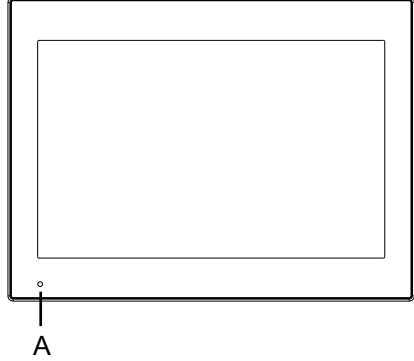
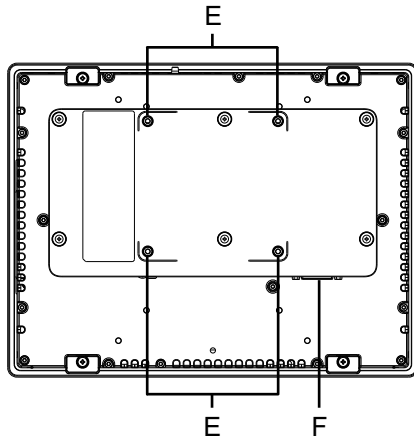
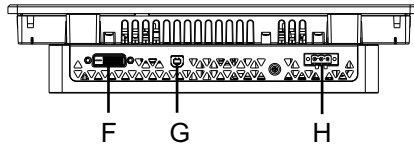
<p>Front</p>	<p>FP-6•00TM</p>  <p>FP-6•00WC</p> 
<p>Rear</p>	
<p>Bottom</p>	

- A. Status LED
- B. Front USB cover

- C. USB 2.0 (Type A)\*<sup>1</sup>
- D. USB 2.0 (micro-B) (this interface is unavailable.)
- E. VESA mount screw hole\*<sup>2</sup>
- F. DVI-D input interface
- G. USB 2.0 (Type B)
- H. Power connector

\*<sup>1</sup> By default, the front USB is disabled. To enable, set in the Launcher, page 56.

\*<sup>2</sup> This product can be mounted to commercially available monitor arms that comply with the VESA standard (100 x 100 mm). Use four M4 screws (screw length: 10 mm [0.4 in]). The necessary torque is 0.7 to 0.8 N•m (6.2 to 7.1 lb-in). VESA mounting is not UL certified.

## LED Indications

### Status LED

You can check the status when connecting to the host using the USB Type B interface.

Color	State	Description
Green	ON	In operation
	Flashing	Screen is turned off
Orange	ON* <sup>1</sup>	S3, S4, S4 (hybrid shutdown)* <sup>2</sup> , S5
	Flashing	USB communication is disconnected
Orange/Red* <sup>3</sup>	Alternating	System monitor error
-	OFF	Power is off.

\*<sup>1</sup> Immediately after hibernation or when HORM is enabled on the host, the LED on this product turns orange right away.

\*<sup>2</sup> S4 (hybrid shutdown) is S5 when Windows® fast startup is enabled.

\*<sup>3</sup> It works only when the host is PS6000 Series.

# Specifications

## What's in This Chapter

General Specifications .....	22
Functional Specifications .....	26
Interface Specifications .....	27

## General Specifications

### Electrical Specifications

		FP-6•00TM	FP-6•00WC
Rated input voltage		24 Vdc	
Input voltage limits		18...31.2 Vdc	
Voltage drop		10 ms or less	
Power consumption	Max	FP-6600TM: 17.6 W FP-6700TM: 22.4 W	FP-6500WC: 12.4 W FP-6600WC: 15.9 W FP-6700WC: 20.0 W FP-6800WC: 30.6 W FP-6900WC: 31.8 W
	When screen turns off the backlight (standby mode)	9.4 W	5.9 W
In-rush current		30 A or less	
Noise immunity		Noise voltage: 1,000 Vp-p Pulse duration: 1 $\mu$ s Rise time: 1 ns (via noise simulator)	
Voltage endurance		1,000 Vac for 1 minute (between charging and FG terminals)	
Insulation resistance		500 Vdc, 10 M $\Omega$ or more (between charging and FG terminals)	

### Environmental Specifications

Use and store this product in areas that conform to the specified conditions.

**NOTE:** When using any of the options for this product, check the specifications for special conditions or cautions that may apply to this product.

Physical environment	
Ambient air temperature (T-Code: T4)	0...55 °C (32...131 °F) (for FP-6800WC and FP-6900WC: 0...50 °C [32...122 °F])
Storage temperature	-20...60 °C (-4...140 °F)
Ambient air and storage humidity	10...90% RH (non-condensing, wet bulb temperature 39 °C [102.2 °F] or less)
Dust	0.1 mg/m <sup>3</sup> (10 <sup>-7</sup> oz/ft <sup>3</sup> ) or less (non-conductive levels)
Pollution degree	For use in Pollution Degree 2 environment
Corrosive gases	Free of corrosive gases
Atmospheric pressure (operating altitude)	800...1,114 hPa (2,000 m [6,561 ft] or lower)
Mechanical environment	

Vibration resistance*1	IEC/EN 61131-2 compliant 5...9 Hz Single amplitude 3.5 mm (0.14 in) 9...150 Hz Fixed acceleration: 9.8 m/s <sup>2</sup> X, Y, Z directions for 10 cycles (approximately 100 minutes)
Shock resistance	IEC/EN 61131-2 compliant 147 m/s <sup>2</sup> , X, Y, Z directions for 3 times
<b>Electrical environment</b>	
Electrical fast transient/burst	IEC 61000-4-4 2 kV: Power port 1 kV: Signal ports
Electrostatic discharge immunity	Contact discharge method: 6 kV Air discharge method: 8 kV (IEC/EN 61000-4-2 Level 3)

\*1 When installed in a panel.

### Air Quality Requirements

Do not operate or store the product where chemicals evaporate, or where chemicals are present in the air:

- Corrosive chemicals: Acids, alkalines, liquids containing salt.
- Flammable chemicals: Organic solvents.

⚠ CAUTION
INOPERATIVE EQUIPMENT
Do not allow water, liquids, metal, and wiring fragments to enter the panel case.
Failure to follow these instructions can result in injury or equipment damage.

### Structural Specifications

#### FP-6●00TM

Grounding	Functional grounding: Grounding resistance of 100 Ω or less, 2 mm <sup>2</sup> (AWG 14) or thicker wire, or your country's applicable standard (SG and FG are connected inside the product.)	
Cooling method	Natural air circulation	
Structure*1	When using a factory-installed front USB cover: IP65F, IP67F, UL 50/50E, Type 1 When using a front USB cover with screw (PFXZCDCVUS1): IP66F, IP67F, UL 50/50E, Type 1, Type 4X (indoor use only), Type 12, Type 13  <b>NOTE:</b> On the front panel when properly installed in an enclosure and not using the front panel USB port.	
External dimensions (W x H x D)	FP-6600TM	315 x 241 x 67.5 mm (12.4 x 9.49 x 2.66 in)
	FP-6700TM	397 x 296 x 67.5 mm (15.63 x 11.65 x 2.66 in)
Panel cut dimensions (W x H) <sup>2 *3</sup>	FP-6600TM	301.5 x 227.5 mm (11.87 x 8.96 in)
	FP-6700TM	383.5 x 282.5 mm (15.1 x 11.12 in)
Weight	FP-6600TM	3.6 kg (8.0 lb) or less
	FP-6700TM	4.9 kg (10.8 lb) or less

\*1 The front face of this product, installed in a solid panel, has been tested using conditions equivalent to the standards shown in the specification. Even though this product's level of resistance is equivalent to these standards, oils that should have no effect on this product can possibly harm this product. This can occur in areas where either vaporized oils are present, or where low viscosity cutting oils

are allowed to adhere to this product for long periods of time. If this product's front face protection sheet or cover glass peels off, these conditions can lead to the ingress of oil into this product and separate protection measures are suggested. Also, if non-approved oils are present, they may cause deformation or corrosion of the front panel's cover. Therefore, prior to installing this product, be sure to confirm the type of conditions that will be present in this product's operating environment.

If the installation gasket is used for a long period of time, or if this product and its gasket are removed from the panel, the original level of protection cannot be kept. To maintain the original protection level, be sure to replace the installation gasket regularly.

\*2 For dimensional tolerance, everything  $+1/-0$  mm ( $+0.04/-0$  in) and R in angle are below R3 (R0.12 in).

\*3 Even if the installation wall thickness is within the recommended range for the Panel Cut Dimensions, depending on wall's material, size, and installation location of this product and other devices, the installation wall could warp. To prevent warping, the installation surface may need to be strengthened.

### FP-6•00WC

Grounding	Functional grounding: Grounding resistance of 100 $\Omega$ or less, 2 mm <sup>2</sup> (AWG 14) or thicker wire, or your country's applicable standard (SG and FG are connected inside the product.)	
Cooling method	Natural air circulation	
Structure <sup>*1</sup>	IP66F, IP67F, UL 50/50E, Type 1, Type 4X (indoor use only), Type 12, Type 13 <b>NOTE:</b> On the front panel when properly installed in an enclosure.	
External dimensions (W x H x D)	FP-6500WC	268.5 x 198.5 x 67.5 mm (10.57 x 7.81 x 2.66 in)
	FP-6600WC	308.5 x 230.5 x 67.5 mm (12.15 x 9.07 x 2.66 in)
	FP-6700WC	408 x 264 x 67.5 mm (16.06 x 10.39 x 2.66 in)
	FP-6800WC	463.6 x 293.6 x 69.5 mm (18.25 x 11.56 x 2.74 in)
	FP-6900WC	532.6 x 330.6 x 69.5 mm (20.97 x 13.02 x 2.74 in)
Panel cut dimensions (W x H) <sup>*2 *3</sup>	FP-6500WC	255 x 185 mm (10.04 x 7.28 in)
	FP-6600WC	295 x 217 mm (16.14 x 8.54 in)
	FP-6700WC	394 x 250 mm (15.51 x 9.84 in)
	FP-6800WC	449.5 x 279.5 mm (17.7 x 11.0 in)
	FP-6900WC	518.5 x 316.5 mm (20.41 x 12.46 in)
Weight	FP-6500WC	3.2 kg (7.1 lb) or less
	FP-6600WC	3.9 kg (8.6 lb) or less
	FP-6700WC	5.3 kg (11.9 lb) or less
	FP-6800WC	6.3 kg (13.9 lb) or less
	FP-6900WC	8.0 kg (17.7 lb) or less

\*1 The front face of this product, installed in a solid panel, has been tested using conditions equivalent to the standards shown in the specification. Even though this product's level of resistance is equivalent to these standards, oils that should have no effect on this product can possibly harm this product. This can occur in areas where either vaporized oils are present, or where low viscosity cutting oils are allowed to adhere to this product for long periods of time. If this product's front face protection sheet or cover glass peels off, these conditions can lead to the ingress of oil into this product and separate protection measures are suggested. Also, if non-approved oils are present, they may cause deformation or corrosion of



the front panel's cover. Therefore, prior to installing this product, be sure to confirm the type of conditions that will be present in this product's operating environment.

If the installation gasket is used for a long period of time, or if this product and its gasket are removed from the panel, the original level of protection cannot be kept. To maintain the original protection level, be sure to replace the installation gasket regularly.

\*2 For dimensional tolerance, everything +1/-0 mm (+0.04/-0 in) and R in angle are below R3 (R0.12 in).

\*3 Even if the installation wall thickness is within the recommended range for the Panel Cut Dimensions, depending on wall's material, size, and installation location of this product and other devices, the installation wall could warp. To prevent warping, the installation surface may need to be strengthened.

<b><i>NOTICE</i></b>
<p><b>EQUIPMENT DAMAGE</b></p> <ul style="list-style-type: none"> <li>• Ensure this product is not in permanent and direct contact with oils.</li> <li>• Do not press on the display of this product with excessive force or with a hard object.</li> <li>• Do not press on the touch panel with a pointed object, such as the tip of a mechanical pencil or a screwdriver.</li> </ul> <p><b>Failure to follow these instructions can result in equipment damage.</b></p>

<b><i>NOTICE</i></b>
<p><b>EQUIPMENT DAMAGE</b></p> <p>Do not expose the device to direct sunlight.</p> <p><b>Failure to follow these instructions can result in equipment damage.</b></p>

<b><i>NOTICE</i></b>
<p><b>STORAGE AND OPERATION OUTSIDE OF SPECIFICATIONS</b></p> <ul style="list-style-type: none"> <li>• Store this product in areas where temperatures are within the product's specifications.</li> <li>• Do not restrict or block the product's ventilation slots.</li> </ul> <p><b>Failure to follow these instructions can result in equipment damage.</b></p>

<b><i>NOTICE</i></b>
<p><b>GASKET AGING</b></p> <ul style="list-style-type: none"> <li>• Inspect the gasket periodically as required by your operating environment.</li> <li>• Change the gasket at least once a year, or as soon as scratches or dirt become visible.</li> </ul> <p><b>Failure to follow these instructions can result in equipment damage.</b></p>

# Functional Specifications

## Display Specifications

### FP-6●00TM

	FP-6600TM	FP-6700TM
Display type	TFT Color LCD	
Display size	12.1"	15"
Resolution	1,024 x 768 pixels (XGA)	
Effective display area (W x H)	245.76 x 184.32 mm (9.68 x 7.26 in)	304.13 x 228.1 mm (11.97 x 8.98 in)
Display colors	16 million colors	
Backlight	White LED (not user replaceable. Please contact customer support.)	
Backlight service life	50,000 hours or more (continuous operation at 25 °C [77 °F] before backlight brightness decreases to 25%)	
Brightness control	0...100 (adjusted with touch panel or software)	

### FP-6●00WC

	FP-6500WC	FP-6600WC	FP-6700WC
Display type	TFT Color LCD		
Display size	10.1"	12.1"	15.6"
Resolution	1,280 x 800 pixels (WXGA)		1,366 x 768 pixels (FWXGA)
Effective display area (W x H)	216.96 x 135.6 mm (8.54 x 5.34 in)	261.12 x 163.2 mm (10.28 x 6.43 in)	344.23 x 193.54 mm (13.55 x 7.62 in)
Display colors	16 million colors		
Backlight	White LED (not user replaceable. Please contact customer support.)		
Backlight service life	50,000 hours or more (continuous operation at 25 °C [77 °F] before backlight brightness decreases to 25%)		
Brightness control	0...100 (adjusted with touch panel or software)		

	FP-6800WC	FP-6900WC
Display type	TFT Color LCD	
Display size	18.5"	21.5"
Resolution	1,920 x 1,080 pixels (FHD)	
Effective display area (W x H)	408.96 x 230.04 mm (16.1 x 9.06 in)	476.64 x 268.11 mm (18.77 x 10.56 in)
Display colors	16 million colors	
Backlight	White LED (not user replaceable. Please contact customer support.)	
Backlight service life	50,000 hours or more (continuous operation at 25 °C [77 °F] before backlight brightness decreases to 25%)	
Brightness control	0...100 (adjusted with touch panel or software)	

## Touch Panel

	FP-6•00TM	FP-6•00WC
Touch panel type	Resistive film (analog)	Projected capacitive with optimized noise filter
Touch points	Multi-touch (two-point touch)	Multi-touch (two-point touch)
Touch panel service life	10 million times or more	10 million times or more
Touch mode	Not applicable	Standard mode, water detection mode, glove mode <b>NOTE:</b> For details, refer to Touch Mode, page 62.

## Interface Specifications

### Specifications of Each Interface

USB (Type A) interface <sup>*1</sup>	Connector	USB 2.0 (Type A) x 1
	Power supply voltage	5 Vdc ±5%
	Maximum supply current	500 mA
	Maximum transmission distance	5 m (16.4 ft)
USB (Type B) interface	Connector	USB 2.0 (Type B) x 1
	Maximum transmission distance	5 m (16.4 ft)
DVI-D input interface	Connector	DVI-D 24 pin (socket) x 1
	Maximum transmission distance	5 m (16.4 ft)

\*1 Only FP-6•00TM.

## Interface Connection

### Cable Connections

**NOTE:** Use only the SELV (Safety Extra-Low Voltage) circuit to connect all interfaces.

<b>▲ WARNING</b>
<p><b>EXPLOSION HAZARD</b></p> <ul style="list-style-type: none"> <li>Always confirm the UL 121201 or CSA C22.2 N°213 hazardous location rating of your device before installing or using it in a hazardous location.</li> <li>To apply or remove the supply power from this product installed in a Class I, Division 2 hazardous location, you must either: A) Use a switch located outside the hazardous environment, or B) Use a switch certified for Class I, Division 1 operation inside the hazardous area.</li> <li>Do not connect or disconnect equipment unless power has been switched off or the area is known to be non-hazardous. This applies to all connections including power, ground, serial, parallel, and network connections.</li> <li>Never use unshielded/ungrounded cables in hazardous locations.</li> <li>Use only non-incendive USB devices.</li> </ul> <p><b>Failure to follow these instructions can result in death, serious injury, or equipment damage.</b></p>

Division 2 hazardous location regulations require that all cable connections be provided with adequate strain relief and positive interlock. Use only non-incendive USB devices as USB connections do not provide adequate strain relief to allow the use of the USB connections of this product. Never connect or disconnect a cable while power is applied at either end of the cable. All communication cables should include a chassis ground shield. This shield should include both copper braid and aluminum foil. The D-sub style connector housing must be a metal conductive type (for example, molded zinc) and the ground shield braid must be terminated directly to the connector housing. Do not use a shield drain wire.

The outer diameter of the cable must be suited to the inner diameter of the cable connector strain relief so that a reliable degree of strain relief is maintained. Always secure the D-sub connectors to the workstation-mating connectors via the two screws located on both sides.

### USB Connection

Non-incendive field wiring apparatus (keyboards, mouse) are permitted for use on the front USB port (Type A) of associated field wiring non-incendive apparatus (this product).

In addition to being non-incendive, any equipment connected to the front USB ports must satisfy the following criteria.

The following figure shows the USB cable wiring (Document No.: NNZ2083601)

#### <Type A>

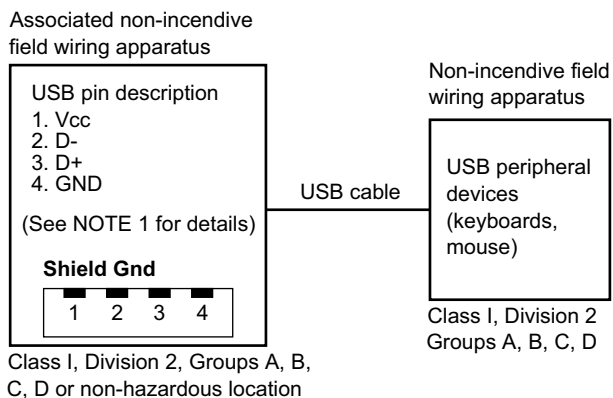

Circuit parameters	Front USB (Type A)
Open-circuit voltage = $V_{oc}$	5.25 Vdc
Short-circuit current = $I_{sc}$	1,560 mA
Associated capacitance = $C_a$	265 $\mu$ F
Associated inductance = $L_a$	16 $\mu$ H

<micro-B>

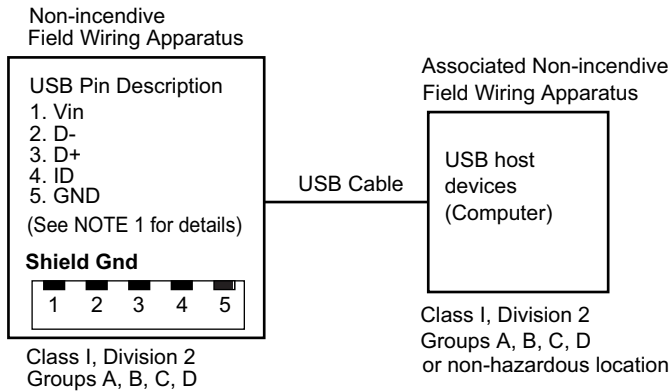

Circuit parameters	Front USB (micro-B)
Maximum input voltage = $V_{max}$	5.25 Vdc
Maximum load current = $I_{max}$	0.1 mA
Internal capacitance = $C_i$	0.12 $\mu$ F
Internal inductance = $L_i$	16 $\mu$ H

**NOTE:**

1. The above tables list the non-incendive circuit parameters.

The Entity Concept allows interconnection of non-incendive apparatus with associated apparatus – not specifically examined combinations – as a system when the approved values of  $V_{oc}$  (or  $U_o$ ) and  $I_{sc}$  (or  $I_o$ ) for the associated apparatus are less than or equal to  $V_{max}$  ( $U_i$ ) and  $I_{max}$  ( $I_i$ ) for the non-incendive apparatus, and the approved values of  $C_a$  ( $C_o$ ) and  $L_a$  ( $L_o$ ) for the associated apparatus are greater than or equal to  $C_i + C_{cable}$  and  $L_i + L_{cable}$ , respectively, for the non-incendive field wiring apparatus.

2. Associated non-incendive field wiring apparatus and non-incendive field wiring apparatus shall satisfy the following:

Associated non-incendive field wiring apparatus	—	Non-incendive field wiring apparatus
$V_{oc}$	$\leq$	$V_{max}$
$I_{sc}$	$\leq$	$I_{max}$
$C_a$	$\geq$	$C_i + C_{cable}$
$L_a$	$\geq$	$L_i + L_{cable}$

3. If the electrical parameters of the cable are unknown, the following values may be used:

$$C_{cable} = 196.85 \text{ pF/m (60 pF/ft)}$$

$$L_{cable} = 0.656 \text{ } \mu\text{H/m (0.20 } \mu\text{H/ft)}$$

4. Wiring methods must be in accordance with the electrical code of the country where it is used.

This product must be installed in an enclosure. If installed in a Class I, Division 2 location, the enclosure must be capable of accepting one or more Division 2 wiring methods.

**⚠ WARNING****EXPLOSION HAZARD**

- Verify the power, input, and output (I/O) wiring are in accordance with Class I, Division 2 wiring methods.
- Do not use this product in hazardous environments or locations other than Class I, Division 2, Groups A, B, C and D.
- Substitution of any components may impair suitability for Class I, Division 2.
- Do not disconnect equipment while the circuit is live or unless the area is known to be free of ignitable concentrations.
- Remove power before attaching or detaching any connectors to or from this product.
- Ensure that power, communication, and accessory connections do not place excessive stress on the ports. Consider the vibration in the environment when making this determination.
- Securely attach power, communication, and external accessory cables to the panel or cabinet.
- Use only commercially available USB cables.
- Use only non-incendive USB configurations.
- Confirm that the USB cable has been attached with the USB cable clamp before using the USB interface.

**Failure to follow these instructions can result in death, serious injury, or equipment damage.**

**DVI-D Input Interface****⚡⚠ DANGER****ELECTRIC SHOCK AND FIRE**

When using the SG terminal to connect an external device to this product:

- Verify that a short-circuit loop is not created when you set up the system.
- Connect the SG terminal to remote equipment when the external device is not isolated.
- Connect the SG terminal to a known reliable ground connection to reduce the risk of damaging the circuit.

**Failure to follow these instructions will result in death or serious injury.**

When this product is connected to the host with the USB Cable accessory, this product receives touch input even if the DVI cable is not connected (and even if the screen is not displayed).

**⚠ WARNING****LOSS OF CONTROL**

- Connect both the DVI cable and the USB cable to connect to the host.
- Do not touch the touch panel area when the DVI cable is not connected.

**Failure to follow these instructions can result in death, serious injury, or equipment damage.**

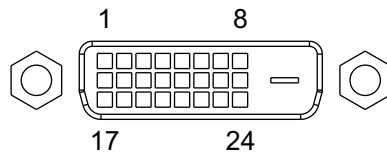

Pin No.	Signal name	Direction
1	TMDS DATA 2-	Input
2	TMDS DATA 2+	Input
3	TMDS DATA 2 SHIELD (SG)	–
4	NC	–
5	NC	–
6	DDC Clock	Input
7	DDC Data	Input/Output
8	NC	–
9	TMDS DATA 1-	Input
10	TMDS DATA 1+	Input
11	TMDS DATA 1 SHIELD (SG)	–
12	NC	–
13	NC	–
14	+5 V	+5 V power input for DDC
15	SHIELD (SG)	–
16	Hot Plug Detect	Output
17	TMDS DATA 0-	Input
18	TMDS DATA 0+	Input
19	TMDS DATA 0 SHIELD (SG)	–
20	NC	–
21	NC	–
22	TMDS CLOCK SHIELD (SG)	–
23	TMDS CLOCK+	Input
24	TMDS CLOCK-	Input
Shell	FG	Frame Ground (Common with SG)

Recommended jack screw is #4-40 (UNC).

For noise-free operation, use the recommended DVI-D cable. Refer to Accessories, page 17.

## Display Resolution

The supported refresh rate is 60 Hz.

Model	Recommended resolution	Horizontal frequency (Hz)	Vertical frequency (Hz)	Pixel clock (MHz)
FP-6600TM/ FP-6700TM	1,024 x 768 (XGA)	48.363	60.004	65.000
FP-6500WC/ FP-6600WC	1,280 x 800 (WXGA)	49.306	59.910	71.000
FP-6700WC	1,366 x 768 (FWXGA)	48.000	60.000	72.000
FP-6800WC/ FP-6900WC	1,920 x 1,080 (FHD)	67.500	60.000	148.500

If you change to a resolution that is not recommended, the display may appear blurry and unclear.

Resolution	Horizontal frequency (Hz)	Vertical frequency (Hz)	Pixel clock (MHz)
640 x 480 (VGA)	31.469	59.940	25.175
800 x 600 (SVGA)	37.879	60.317	40.000
1,024 x 768 (XGA)	48.363	60.004	65.000



# Dimensions

## What's in This Chapter

External Dimensions (FP-6600TM) .....	33
External Dimensions (FP-6700TM) .....	34
External Dimensions (FP-6500WC) .....	34
External Dimensions (FP-6600WC) .....	35
External Dimensions (FP-6700WC) .....	36
External Dimensions (FP-6800WC) .....	36
External Dimensions (FP-6900WC) .....	37
Installation Fastener .....	37

## External Dimensions (FP-6600TM)

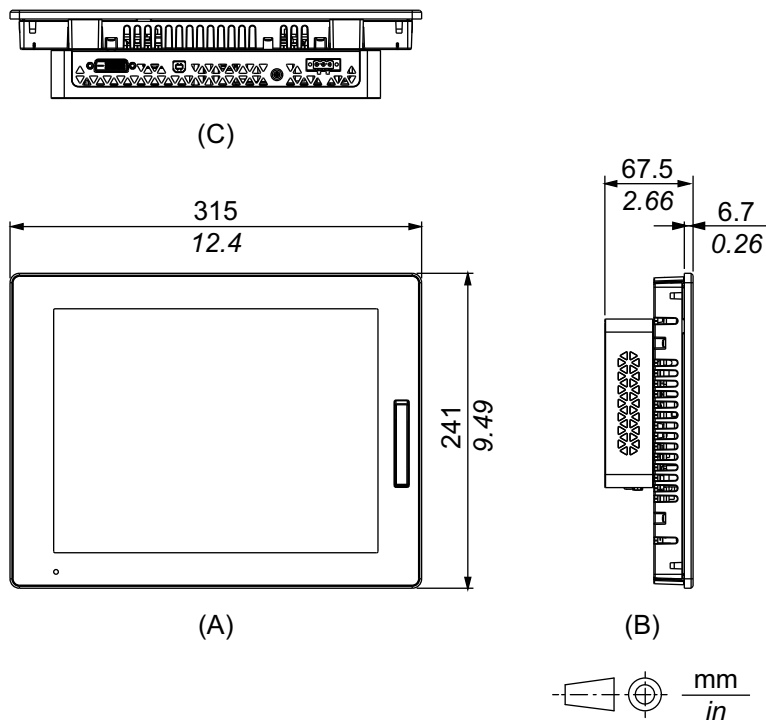

- A. Front
- B. Left
- C. Bottom

## External Dimensions (FP-6700TM)

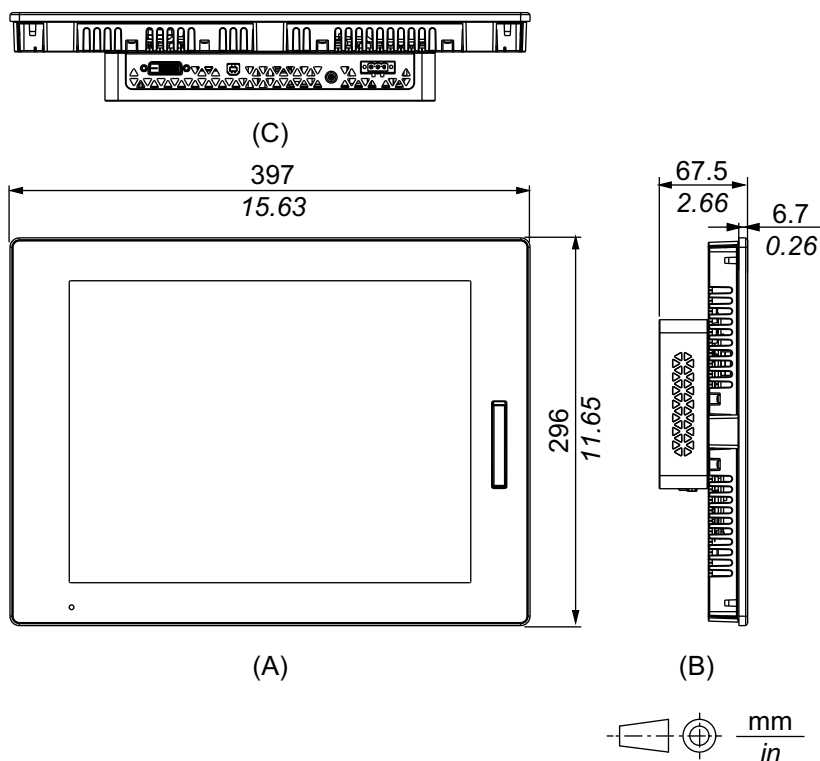

- A. Front
- B. Left
- C. Bottom

## External Dimensions (FP-6500WC)

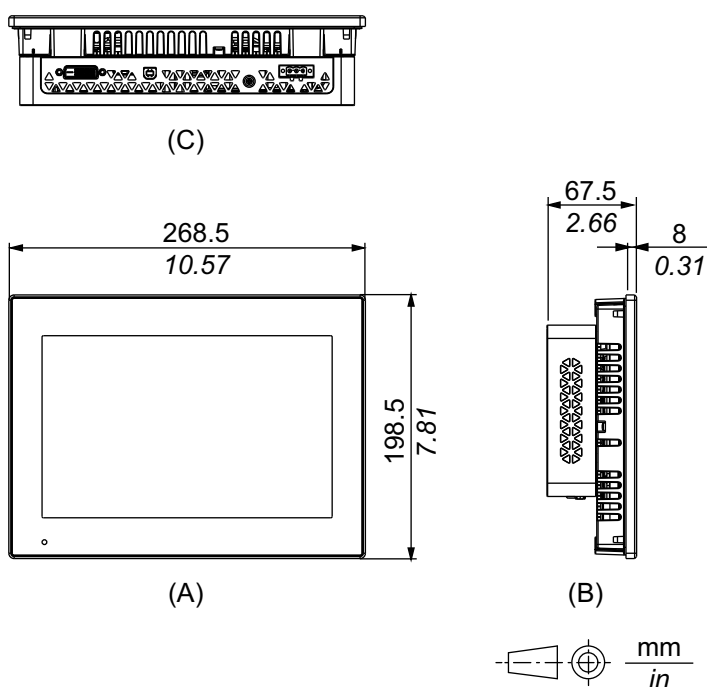

- A. Front
- B. Left
- C. Bottom

### External Dimensions (FP-6600WC)

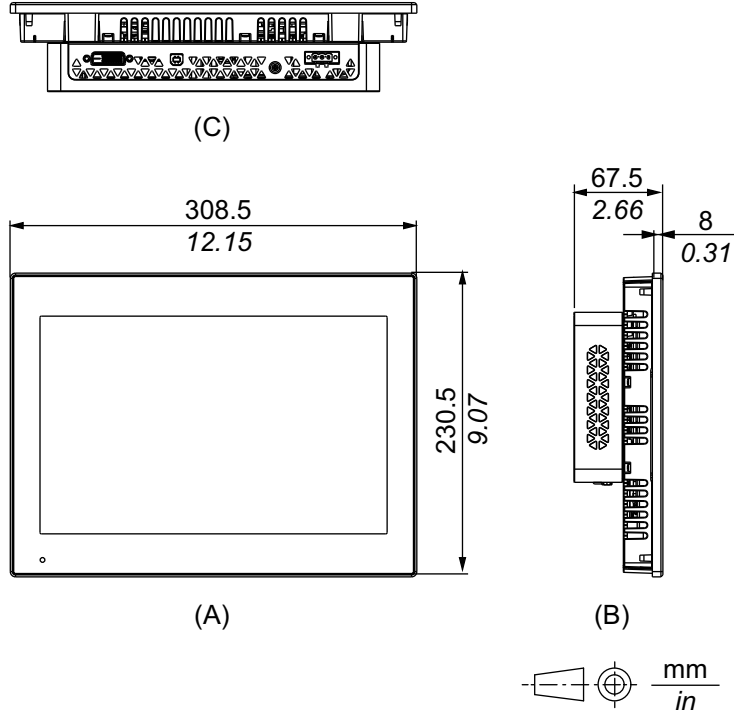

- A. Front
- B. Left
- C. Bottom

## External Dimensions (FP-6700WC)

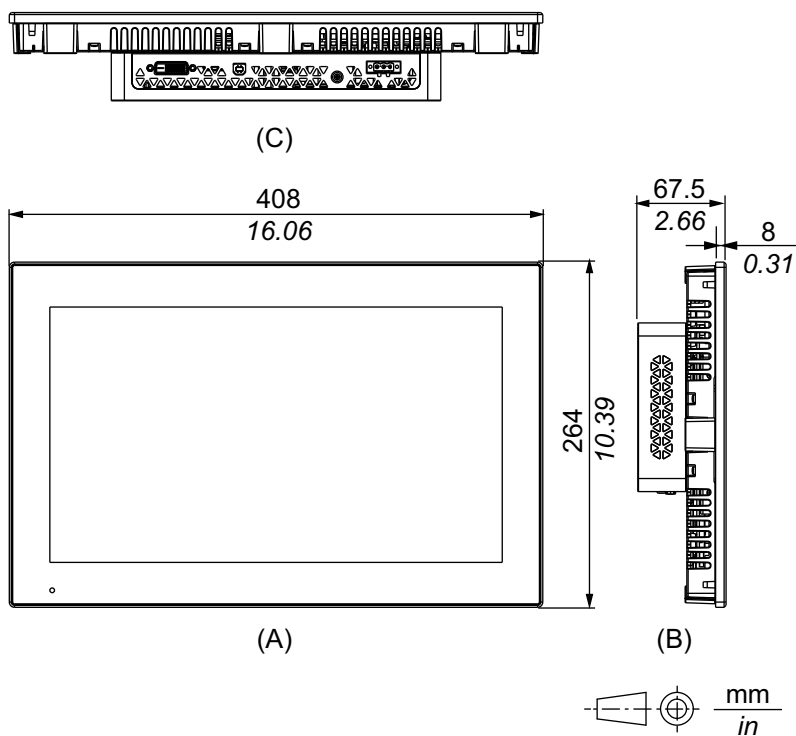

- A. Front
- B. Left
- C. Bottom

## External Dimensions (FP-6800WC)

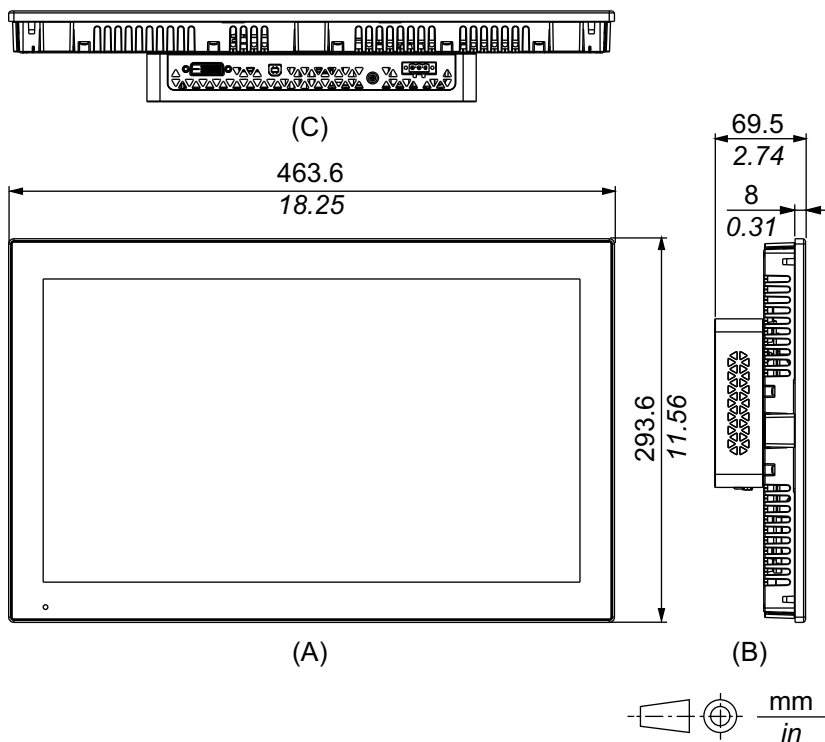

- A. Front
- B. Left
- C. Bottom

## External Dimensions (FP-6900WC)

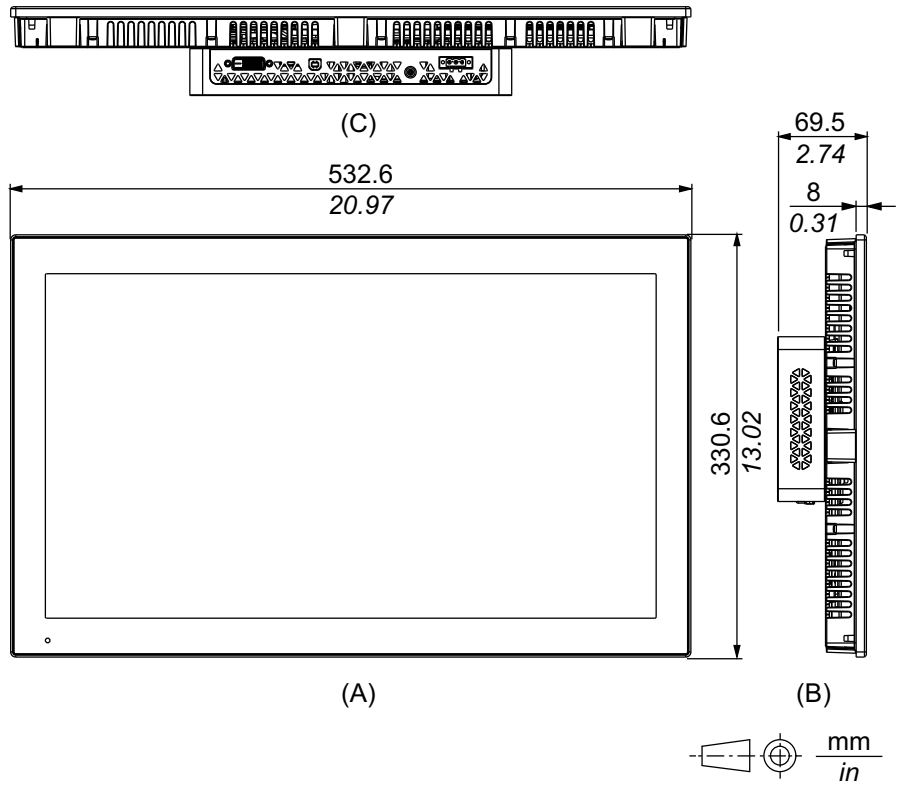

- A. Front
- B. Left
- C. Bottom

## Installation Fastener

### External Dimensions

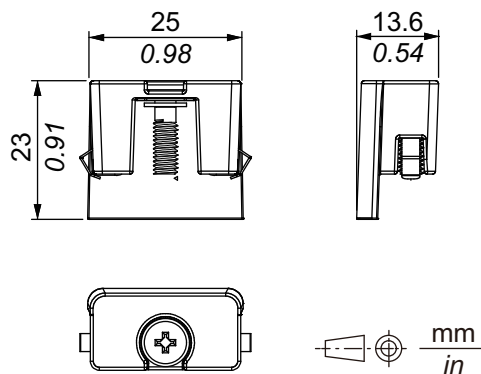

# Installation and Wiring

## What's in This Chapter

Installation .....	38
Wiring the Power Supply .....	44
USB Cable Clamp .....	49
Front USB Cover .....	51

## Installation

### Precautions for Building into an End-use Product

This product is designed for use on flat surfaces of UL 50/50E, Type 1, Type 4X (indoor use only), Type 12 or Type 13 enclosure.

Mount this product in an enclosure that provides a clean, dry, robust and controlled environment (IP65F, IP66F, IP67F, UL 50/50E, Type 1, Type 4X [indoor use only], Type 12 or Type 13 enclosure).

For FP-6•00WC, the front surface is rated for IP66F, IP67F, UL 50/50E, Type 1, Type 4X (indoor use only), Type 12 and Type 13 enclosure.

For FP-6•00TM, when using a factory-installed front USB cover (without screw), the front surface is rated for IP65F, IP67F, UL 50/50E and Type 1 enclosures. When using a front USB cover (with screw) (PFXZCDCVUS1), the front surface is rated for IP66F, IP67F, UL 50/50E, Type 1, Type 4X (indoor use only), Type 12 and Type 13 enclosure.

Display front surface		Enclosure front surface
FP-6•00TM		
Without screw	With screw	FP-6•00WC
IP65F, IP67F, UL 50/50E, Type 1	IP66F, IP67F, UL 50/50E, Type 1, Type 4X (indoor use only), Type 12, Type 13	IP66F, IP67F, UL 50/50E, Type 1, Type 4X (indoor use only), Type 12, Type 13
		IP65F, IP66F, IP67F, UL 50/50E, Type 1, Type 4X (indoor use only), Type 12, Type 13

For FP-6•00TM, regardless of using a factory-installed front USB cover or a front USB cover with screw, when the front USB cover is open, the front surface is rated for UL 50/50E and Type 1 enclosure.

Be aware of the following when building this product into an end-use product:

- The rear face of this product is not approved as an enclosure. When building this product into an end-use product, be sure to use an enclosure that satisfies standards as the end-use product's overall enclosure.
- Install this product in an enclosure with mechanical rigidity.
- This product is not designed for outdoor use. UL certification obtained is for indoor use only.
- Install and operate this product with its front panel facing outward.

**NOTE:** IP65F, IP66F and IP67F are not part of UL certification.

### **▲ CAUTION**

#### **RISK OF BURNING INJURY**

- Do not touch the bezel or rear chassis during operation.
- Wear appropriate gloves when operating the front USB in ambient temperatures greater than 45 °C (113 °F).

**Failure to follow these instructions can result in injury or equipment damage.**

## Installation Requirements

- Check that the installation wall or cabinet surface is flat, in good condition and has no jagged edges. Metal reinforcing strips may be attached to the inside of the wall, near the panel-cut, to increase its rigidity.
- Decide on the thickness of the enclosure wall, based on the level of strength required. Even if the installation wall thickness is within the recommended range for the Panel Cut Dimensions, depending on wall's material, size, and installation location of this product and other devices, the installation wall could warp. To prevent warping, the installation surface may need to be strengthened.
- Check that the ambient air temperature and the ambient humidity are within their specified ranges in *Environmental Specifications*, page 22. When installing this product in a cabinet or enclosure, the ambient air temperature is the cabinet's or enclosure's internal and external temperature.

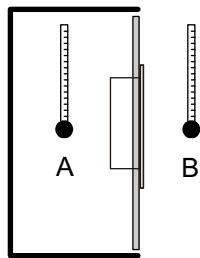

- A. Internal temperature
- B. External temperature

- Be sure that heat from surrounding equipment does not cause this product to exceed its standard operating temperature.
- When mounting this product in portrait orientation, ensure that the right side of this product faces up. In other words, the DC power connector should be at the top.

**NOTE:** For portrait orientation mounting, make sure your screen editing software supports the function.

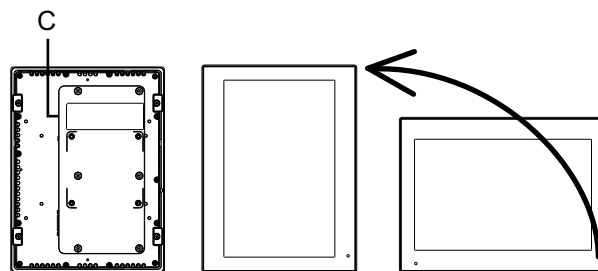

- C. Power connector

- When installing this product in a slanted position, the product face should not incline more than 30°.

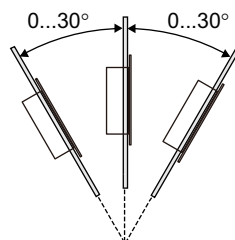

- For easier maintenance, operation and improved ventilation, install this product at least 100 mm (3.94 in) away from adjacent structures and other equipment as shown in the following illustration:

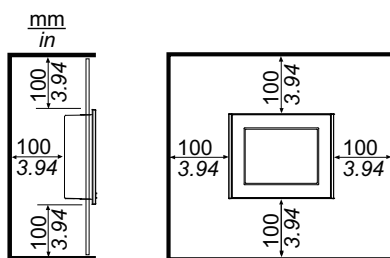

### Pressure Differences

When applying and installing this product, it is important that steps are taken to eliminate any pressure difference between the inside and the outside of the enclosure in which this product is mounted. Higher pressure inside the enclosure can cause delamination of the front membrane of the display. Even a small pressure difference inside the enclosure will act on the large area of the membrane and can result in sufficient force to delaminate the membrane and thus cause failure of the touch capability. Pressure differences can often occur in applications where there are multiple fans and ventilators moving air at different rates in different rooms. Please follow these techniques to ensure that this product's function is not impacted by this mis-application:

- Seal all conduit connections inside of the enclosure, especially those that lead to other rooms that may be at a different pressure.
- Where applicable, install a small weep hole at the bottom of the enclosure to allow equalization of the internal and external pressure.

### Panel Cut Dimensions

Based on the panel cut dimensions, open a mount hole on the panel.

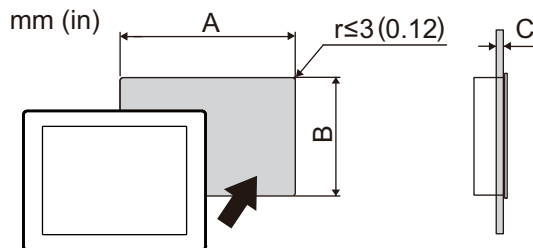

Model Name		
A	B	C
<b>FP-6600TM (12-inch)</b>		
301.5 mm (+1/-0 mm) (11.87 in [+0.04/-0 in])	227.5 mm (+1/-0 mm) (8.96 in [+0.04/-0 in])	1.6...5 mm (0.06...0.2 in)
<b>FP-6700TM (15-inch)</b>		
383.5 mm (+1/-0 mm) (15.1 in [+0.04/-0 in])	282.5 mm (+1/-0 mm) (11.12 in [+0.04/-0 in])	1.6...5 mm (0.06...0.2 in)
<b>FP-6500WC (10-inch Wide)</b>		
255 mm (+1/-0 mm) (10.04 in [+0.04/-0 in])	185 mm (+1/-0 mm) (7.28 in [+0.04/-0 in])	1.6...3 mm (0.06...0.12 in)
<b>FP-6600WC (12-inch Wide)</b>		
295 mm (+1/-0 mm) (11.61 in [+0.04/-0 in])	217 mm (+1/-0 mm) (8.54 in [+0.04/-0 in])	1.6...5 mm (0.06...0.2 in)



Model Name		
A	B	C
<b>FP-6700WC (15-inch Wide)</b>		
394 mm (+1/-0 mm) (15.51 in [+0.04/-0 in])	250 mm (+1/-0 mm) (9.84 in [+0.04/-0 in])	1.6...5 mm (0.06...0.2 in)
<b>FP-6800WC (19-inch Wide)</b>		
449.5 mm (+1/-0 mm) (17.7 in [+0.04/-0 in])	279.5 mm (+1/-0 mm) (11.0 in [+0.04/-0 in])	1.6...5 mm (0.06...0.2 in)
<b>FP-6900WC (22-inch Wide)</b>		
518.5 mm (+1/-0 mm) (20.41 in [+0.04/-0 in])	316.5 mm (+1/-0 mm) (12.46 in [+0.04/-0 in])	1.6...5 mm (0.06...0.2 in)

## Installation Procedure

**⚠️⚠️ DANGER**

**HAZARD OF ELECTRIC SHOCK, EXPLOSION, OR ARC FLASH**

- Remove all power from the device before removing any covers or elements of the system, and prior to installing or removing any accessories, hardware, or cables.
- Unplug the power cable from both this product and the power supply prior to installing or removing the product.
- Always use a properly rated voltage sensing device to confirm power is off where and when indicated.
- Replace and secure all covers or elements of the system before applying power to this product.
- Use only the specified voltage when operating this product. This product is designed to use 24 Vdc. Always check whether your device is DC powered before applying power.
- When using this product in Class I, Division 2, Groups A, B, C, and D hazardous locations, install this product in an enclosure that prevents the operator from touching the back of this product without the use of tools.

**Failure to follow these instructions will result in death or serious injury.**

**NOTICE**

**EQUIPMENT DAMAGE**

Keep this product stabilized in the panel cut while you are installing or removing the screw fasteners.

**Failure to follow these instructions can result in equipment damage.**

**NOTICE**

**BROKEN ENCLOSURE**

Do not exert more torque than the amount specified.

**Failure to follow these instructions can result in equipment damage.**

- Check that the gasket is seated securely into the bezel’s groove, which runs around the perimeter of the display panel frame.
 

**NOTE:** Always use the installation gasket, since it absorbs vibration in addition to repelling water. For the procedure on replacing the installation gasket, refer to Replacing the Installation Gasket, page 54.

- Based on the Panel Cut Dimensions, page 40, open a mount-hole on the panel and attach this product to the panel from the front side.

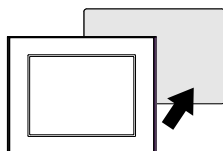

- Confirm that the anti-drop lock on the top of this product is attached to the panel.

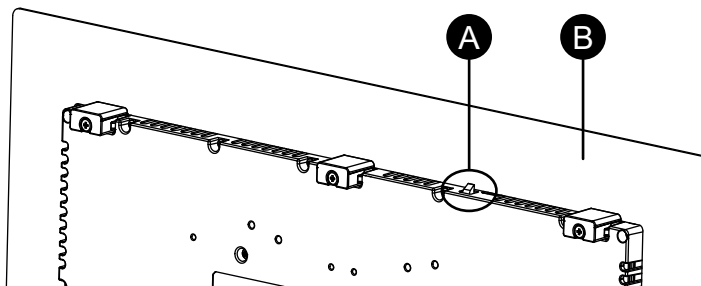

- A. Anti-drop lock
- B. Panel

- Insert the installation fasteners into the bracket openings at the top, bottom, left and right, and use a screwdriver to tighten the screws little by little, alternating between diagonally-positioned screws.

**NOTE:** The necessary torque is 0.7 N•m (6.2 lb-in).

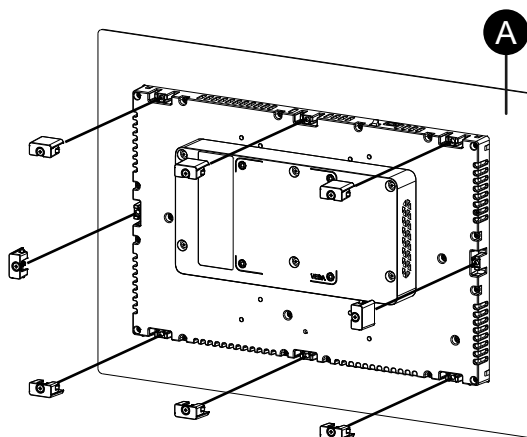

- A. Panel

The number of installation fasteners for each model is as follows.

FP-6600TM, FP-6500WC, FP-6600WC	Top - 2, Bottom - 2
FP-6700TM, FP-6700WC, FP-6800WC, FP-6900WC	Top - 3, Bottom - 3, Left - 1, Right - 1

## Removal Procedure

### **⚠️⚠️ DANGER**

#### **HAZARD OF ELECTRIC SHOCK, EXPLOSION, OR ARC FLASH**

- Remove all power from the device before removing any covers or elements of the system, and prior to installing or removing any accessories, hardware, or cables.
- Unplug the power cable from both this product and the power supply prior to installing or removing the product.
- Always use a properly rated voltage sensing device to confirm power is off where and when indicated.
- Replace and secure all covers or elements of the system before applying power to this product.
- Use only the specified voltage when operating this product. This product is designed to use 24 Vdc. Always check whether your device is DC powered before applying power.

**Failure to follow these instructions will result in death or serious injury.**

### **⚠️ CAUTION**

#### **RISK OF INJURY**

Do not drop this product when you remove it from the panel.

- Hold this product in place after removing the fasteners.
- Use both hands.
- While pushing on the anti-drop lock, be careful not to hurt your fingers.

**Failure to follow these instructions can result in injury or equipment damage.**

### **NOTICE**

#### **EQUIPMENT DAMAGE**

- Keep this product stabilized in the panel cut while you are installing or removing the screw fasteners.
- Remove this product while pushing the anti-drop lock or by making sure the lock does not touch the panel.

**Failure to follow these instructions can result in equipment damage.**

1. Using a screwdriver, gradually loosen the screws for the fasteners (top, bottom, left, and right), alternating diagonally between screws until all screws are loose.

**NOTE:** For the number of installation fasteners on your model, see Number of Installation Fasteners in step 4 of Installation Procedure, page 41.

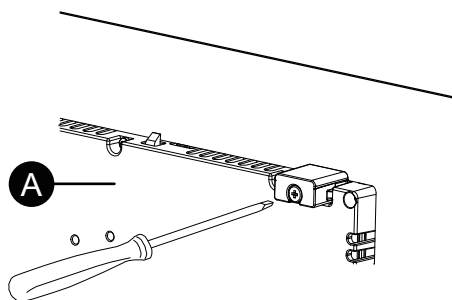

A. Rear side

- While pushing on the anti-drop lock on the top of this product, slowly remove this product from the panel.

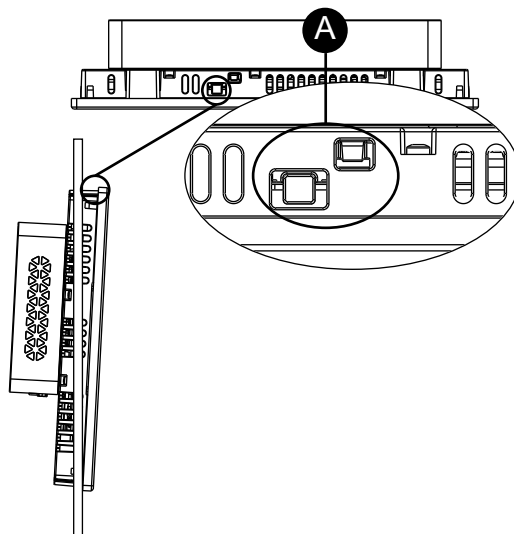

A. Anti-drop lock

## Wiring the Power Supply

### DC Power Cord Preparation

- Make sure the ground wire is either the same or heavier gauge than the power wires.
- Do not use aluminum wires in the power supply's power cord.
- To prevent the possibility of a terminal short, use a pin terminal that has an insulating sleeve.
- If the ends of the individual wires are not twisted correctly, the wires may create a short circuit.
- The conductor type is solid or stranded wire.
- Use copper wire rated for 75 °C (167 °F) or higher.
- Use the SELV (Safety Extra-Low Voltage) circuit and LIM (Limited Energy) circuit for DC input.

Recommended cross section	0.75...3.5 mm <sup>2</sup> (18...12 AWG) <sup>1</sup>
Conductor type	Solid or stranded wire <sup>2</sup>
Conductor length	 $\frac{10}{0.39}$ $\frac{\text{mm}}{\text{in}}$
Recommended driver <sup>3</sup>	SZS 0.6x3.5 (1205053)
Recommended pin terminals <sup>3</sup>	3201288 AI 0,75-10 GY 3200182 AI 1 -10 RD 3200195 AI 1,5 -10 BK 3202533 AI 2,5 -10 BU
Recommended pin terminal crimp tool <sup>3</sup>	CRIMPFOX 6

\*1 Since a high level of current flows in the DC model, thick wires are recommended to minimize voltage drops due to wiring.

\*2 When using stranded wires, confirm the level of current supported by the wire.

\*3 Items are manufactured by Phoenix Contact.

### Connecting the DC Power Cord

**⚠️ ⚠️ DANGER**

**HAZARD OF ELECTRIC SHOCK, EXPLOSION, OR ARC FLASH**

- Remove all power from the device before removing any covers or elements of the system, and prior to installing or removing any accessories, hardware, or cables.
- Remove power before wiring this product’s power terminals.
- Always use a properly rated voltage sensing device to confirm power is off where and when indicated.
- Replace and secure all covers or elements of the system before applying power to this product.
- Use only the specified voltage when operating this product. This product is designed to use 24 Vdc. Always check whether your device is DC powered before applying power.
- Since this product is not equipped with a power switch, be sure to connect a power switch to the power supply.
- Be sure to ground this product’s FG terminal.

**Failure to follow these instructions will result in death or serious injury.**

**NOTE:**

- The SG (signal ground) and FG (frame ground) terminals are connected internally in this product.
- When the FG terminal is connected, be sure the wire is grounded. Not grounding this product can result in excessive electromagnetic interference (EMI).

**DC Power Connector: Spring Clamp Terminal Blocks**

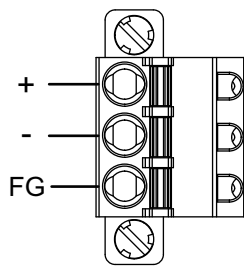

Connection	Wire
+	24 Vdc
-	0 Vdc
FG	Grounded terminal connection to the panel chassis.

**How to connect the DC Power Cord**

1. Confirm the power cord is not connected to the power supply.
2. Crimp a pin terminal properly to the end of each power cable wire.
3. Push the opening button with a small and flat screwdriver to open the desired pin hole.

- Insert each power cord wire into its corresponding hole. Release the opening button to clamp the wire in place.

**NOTE:**

- When using stranded wire, do not short with neighboring wires.
- When connecting with stranded wires, do not solder the stranded wires.
- If the wire is not inserted into the FG terminal properly, touch may not respond normally.

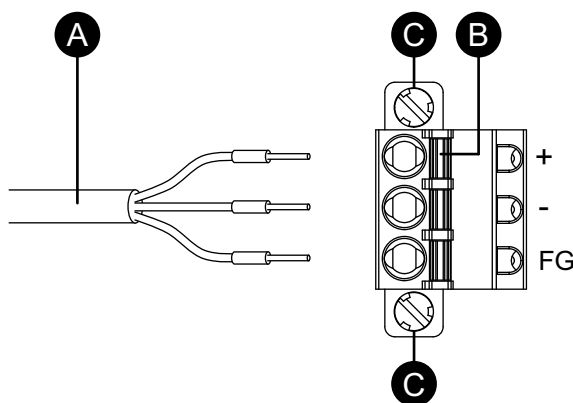

- A. Power cord  
 B. Opening button  
 C. Screw

- After inserting all three power cord wires, insert the DC power connector into the power connector on this product.

## Power Supply Precautions

### **⚡⚠ DANGER**

#### **SHORT CIRCUIT, FIRE, OR UNINTENDED EQUIPMENT OPERATION**

- Install and fasten this product in an installation panel or cabinet prior to connecting power supply and communication lines.
- Securely attach power cables to an installation panel or cabinet.
- Avoid excessive force on the power cable.

**Failure to follow these instructions will result in death or serious injury.**

## Improving Noise/Surge Resistance

- This product's power cord should not be bundled with or kept close to main circuit lines (high voltage, high current), power lines, or input/output lines, and their various systems should be kept separate. When power lines cannot be wired via a separate system, use shielded cables for input/output lines.
- Make the power cord as short as possible, and be sure to twist the ends of the wires together (i.e. twisted pair cabling) from close to the power supply unit.
- If there is an excess amount of noise on the power supply line, reduce the noise with a noise filter before turning on the power.
- Connect a surge protection device to handle power surges.
- To increase noise resistance, attach a ferrite core to the power cable.

## Power Supply Connections

- When supplying power to this product, connect the power as shown below.

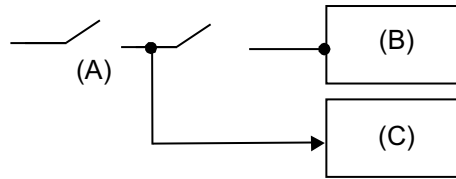

- A. Main power
- B. This product
- C. Other unit

- Use the SELV (Safety Extra-Low Voltage) circuit and LIM (Limited Energy) circuit for DC input.
- The following shows a surge protection device connection:

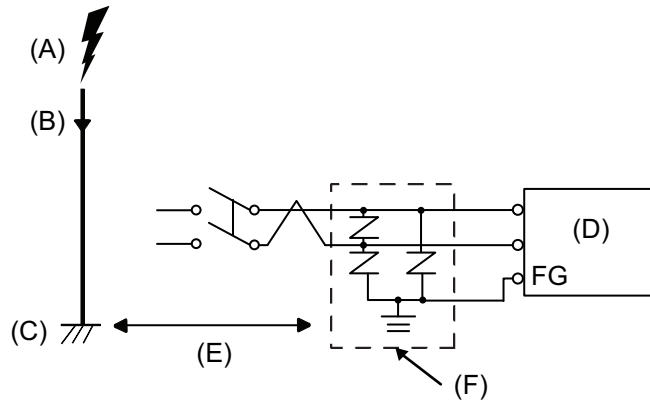

- A. Lightning
- B. Lightning rod
- C. Ground
- D. This product
- E. Provide adequate distance
- F. Surge protection device

- Attach a surge protection device to prevent damage to this product as a result of a lightning induced power surge from a large electromagnetic field generated from a direct lightning strike.

We also strongly recommend to connect the crossover grounding wire of this product to a position close to the ground terminal of the surge protection device.

It is expected that there will be an effect on this product due to fluctuations in grounding potential when there is a large surge flow of electrical energy to the lightning rod ground at the time of a lightning strike. Provide adequate distance between the lightning rod grounding point and the surge protection device grounding point.

- If the voltage variation is outside the prescribed range, connect a regulated power supply.

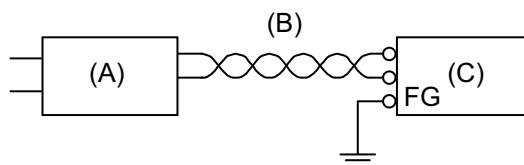

- A. Regulated power supply
- B. Twisted-pair cord
- C. This product

## Grounding

### Independent Grounding

Always ground the FG (functional ground) terminal. Be sure to separate this product from the FG of other devices as shown below.

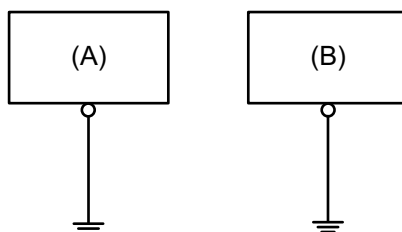

- A. This product
- B. Other equipment

### Precautions

- Check that the grounding resistance is 100  $\Omega$  or less.\*1
- The FG wire should have a cross sectional area 2 mm<sup>2</sup> (AWG14) or greater\*1. Create the connection point as close as possible to this product, and make the wire as short as possible. When using a long grounding wire, replace the thin wire with a thicker wire, and place it in a duct.
- The SG (signal ground) and FG (functional ground) terminals are connected internally in this product. When connecting the SG line to another device, be sure that no ground loop is formed.

\*1 Observe local codes and standards.

### Common Grounding

Electromagnetic Interference (EMI) can be created if devices are improperly grounded. EMI can cause loss of communication. If exclusive grounding is not possible, use a common grounding point as shown in the configuration below. Do not use any other configuration for common grounding.



Correct grounding

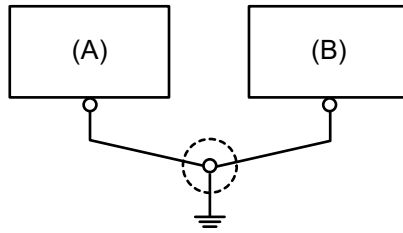

- A. This product
  - B. Other equipment
- Incorrect grounding

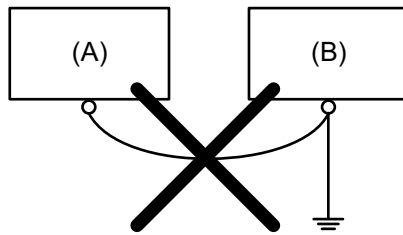

- A. This product
- B. Other equipment

## USB Cable Clamp

### Attaching USB Clamp Type B

When using a USB device, attach a USB cable clamp to the USB interface to prevent the USB cable from being disconnected.

## ⚠ WARNING

### EXPLOSION HAZARD

- Verify the power, input, and output (I/O) wiring are in accordance with Class I, Division 2 wiring methods.
- Do not use this product in hazardous environments or locations other than Class I, Division 2, Groups A, B, C and D.
- Substitution of any components may impair suitability for Class I, Division 2.
- Do not disconnect equipment while the circuit is live or unless the area is known to be free of ignitable concentrations.
- Remove power before attaching or detaching any connectors to or from this product.
- Ensure that power, communication, and accessory connections do not place excessive stress on the ports. Consider the vibration in the environment when making this determination.
- Securely attach power, communication, and external accessory cables to the panel or cabinet.
- Use only commercially available USB cables.
- Use only non-incendive USB configurations.
- Confirm that the USB cable has been attached with the USB cable clamp before using the USB interface.

**Failure to follow these instructions can result in death, serious injury, or equipment damage.**

1. Attach the bracket to the rear of this product and secure it with two screws.

**NOTE:** The necessary torque is 0.7 N•m (6.2 lb-in).

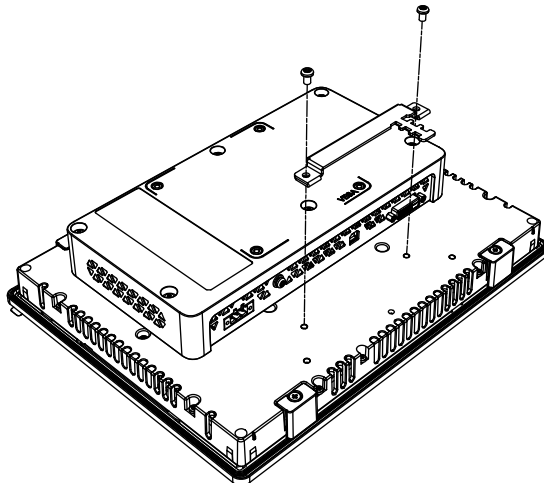

2. Orient the USB cable as shown and insert into the USB interface.

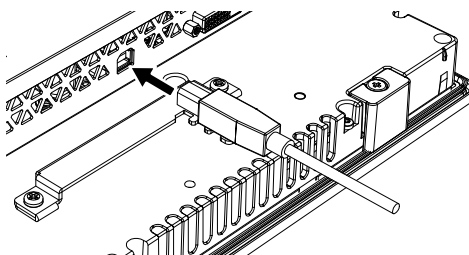

3. Rotate the tie as shown to secure the USB cable to the bracket and so that the USB cable can pass through the center of the tie loop.

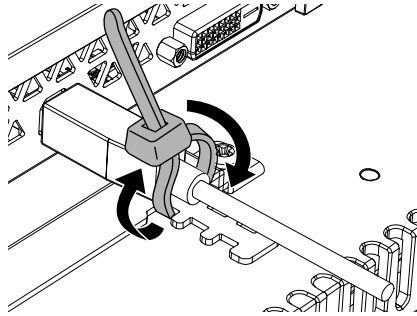

**NOTE:** You can substitute the tie with a commercially available tie with a width of 4.8 mm (0.19 in) and a thickness of 1.3 mm (0.05 in).

## Front USB Cover

### Opening the Front USB Cover

For FP-6●00TM, when using a factory-installed front USB cover (without screw), the front surface is rated for IP65F, IP67F, UL 50/50E, or Type 1 enclosure. When using a front USB cover (with screw) (PFXZCDCVUS1), the front surface is rated for IP66F, IP67F, UL 50/50E, Type 1, Type 4X (indoor use only), Type 12 and Type 13 enclosure.

Regardless of using a factory-installed front USB cover or a front USB cover with screw, when the cover is open, the front surface is rated for UL 50/50E and Type 1 enclosure.

**NOTE:** IP65F, IP66F and IP67F are not part of UL certification.

### **▲ CAUTION**

#### **RISK OF INJURY**

When opening the Front USB Cover, be careful not to injure your fingers.

**Failure to follow these instructions can result in injury or equipment damage.**

### **NOTICE**

#### **BROKEN ENCLOSURE**

Do not exert more torque than the amount specified.

**Failure to follow these instructions can result in equipment damage.**

1. Place your finger or a tool (such as a screwdriver) in the gap on the top of the front USB cover and pull out as illustrated.

**NOTE:**

- When using front USB cover (PFXZCDCVUS1), loosen the top screw using a screwdriver.
- The necessary torque is 0.5 N•m (4.4 lb-in).

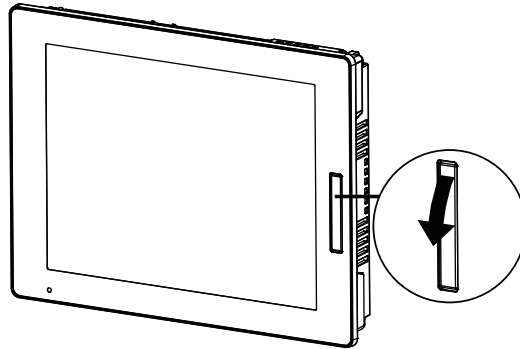

2. The USB interface can be seen once you pull out the front USB cover.

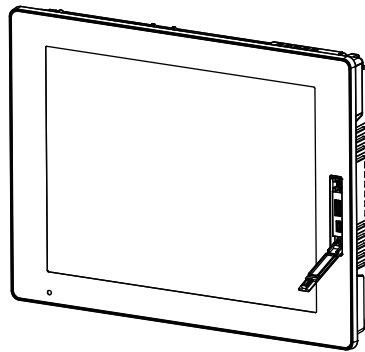

# Maintenance

## What's in This Chapter

Regular Cleaning .....	53
Periodic Check Points.....	53
Replacing the Installation Gasket.....	54
Replacing the Backlight .....	54
After-sales Service .....	54

## Regular Cleaning

### Cleaning this product

#### **NOTICE**

##### **EQUIPMENT DAMAGE**

- Power off this product before cleaning it.
- Do not use hard or pointed objects to operate the touch panel.
- Do not use paint thinner, organic solvents, or a strong acid compound to clean the unit.

**Failure to follow these instructions can result in equipment damage.**

When this product gets dirty, wipe this product with a soft, dry cloth or a soft cloth soaked in only water and wrung tightly.

**NOTE:** When the product is very dirty, soak the soft cloth in water with a neutral detergent, wring the cloth tightly and wipe the product while avoiding the product label.

## Periodic Check Points

### Operation Environment

- Is the ambient air temperature within the allowable range? Refer to Environmental Specifications, page 22.
- Is the ambient air humidity within the specified range? Refer to Environmental Specifications, page 22.

When this product is inside a panel, the ambient environment refers to the interior of the panel.

### Electrical Specifications

- Is the input voltage appropriate? Refer to Electrical Specifications, page 22.
- Are all power cords and cables connected properly? Are there any loose cables?
- Are all mounting brackets holding the unit securely?
- Are there scratches or traces of dirt on the installation gasket?

### Unit Disposal

When disposing this product, dispose it in a manner appropriate to, and in accordance with, your country's industrial machinery disposal/recycling standards.

## Replacing the Installation Gasket

The installation gasket provides protection against dust and moisture. The gasket must be inserted correctly into the groove for moisture resistance for this product.

### NOTICE

#### GASKET AGING

- Inspect the gasket periodically as required by your operating environment.
- Change the gasket at least once a year, or as soon as scratches or dirt become visible.

**Failure to follow these instructions can result in equipment damage.**

### NOTICE

#### EQUIPMENT DAMAGE

Be careful not to stretch the gasket unnecessarily.

**Failure to follow these instructions can result in equipment damage.**

### Installing the Installation Gasket

1. Place this product on a flat, level surface, with the display face pointing down.
2. Remove the gasket from this product.
3. Attach the new gasket to this product. Insert the protrusions from the four corners of the gasket into the corresponding holes in the corners of this product.

Depending on your model, there may be additional protrusions. In the following, refer to the figure on the right and insert the protrusions accordingly.

**NOTE:** When using a tool to insert the gasket, make sure the tool does not catch the rubber gasket and cause a tear.

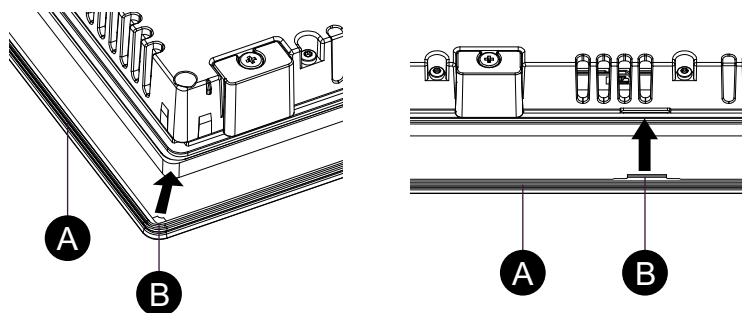

A. Installation gasket

B. Protruding point

## Replacing the Backlight

Not user replaceable. Please contact customer support.

## After-sales Service

For details on after-sales service, refer to our website.

<https://www.pro-face.com/trans/en/manual/1001.html>

# System Specification and Launcher

## What's in This Chapter

System Specifications.....	55
Settings Workflow .....	55
Launcher .....	56

## System Specifications

For touch input data communication between this product and the host, and for adjustment of the screen display, the communication driver and utilities must be installed on the host.

You can download the utilities (FP6UtilityInstaller.zip) from our website. The driver will be installed automatically when the utility is installed.  
<https://www.pro-face.com/trans/en/manual/1001.html>

## Operation System

The supported operating systems are listed on the website from which you can download the utilities for this product.

## Utility

The utilities you can use on this product are as follows. For more information about each of the following utilities, refer to *Launcher*, page 56.

Launcher:

- Buzzer
- Brightness
- Calibration
- Front USB
- Touch Mode

## Settings Workflow

Follow the steps below to configure the software.

1. Configure the display settings from the screen properties (Screen Resolution) for your host.
2. Download and install the utilities onto the host.  
**NOTE:** To use these utilities, Microsoft®.NET Framework is required. If .NET Framework is not installed, the .NET Framework installation screen will appear. Install following the on-screen instructions.
3. Start the Launcher.
4. Configure the utilities as needed, in any order.

# Launcher

## Starting the Launcher

The Launcher is a utility that you can set up to start programs and settings. The Launcher allows for convenient touch-screen operation by displaying icons for registered various settings.

Download the utilities (FP6UtilityInstaller.zip) from our website and install them on the host to which this product is connected.

<https://www.pro-face.com/trans/en/manual/1001.html>

After installation, a shortcut icon is created on the desktop. You can start the Launcher from the shortcut icon.

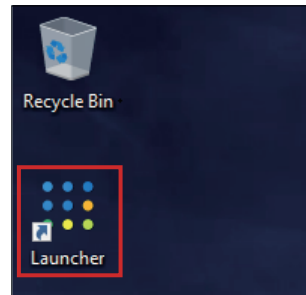

When the Launcher is installed on the host other than PS6000 Series:

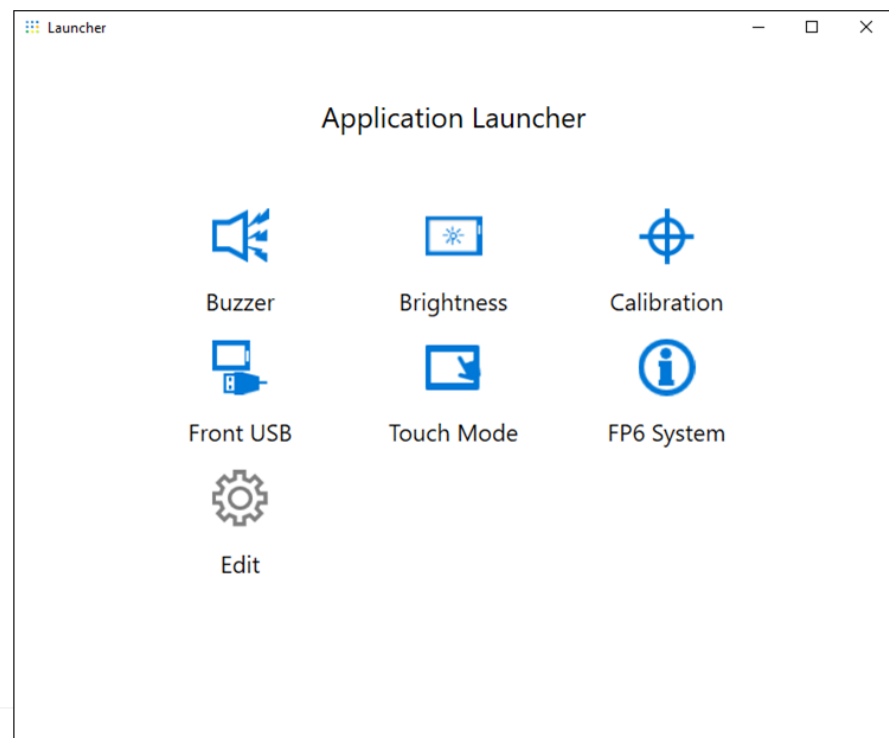

When the Launcher is installed on PS6000 Series:

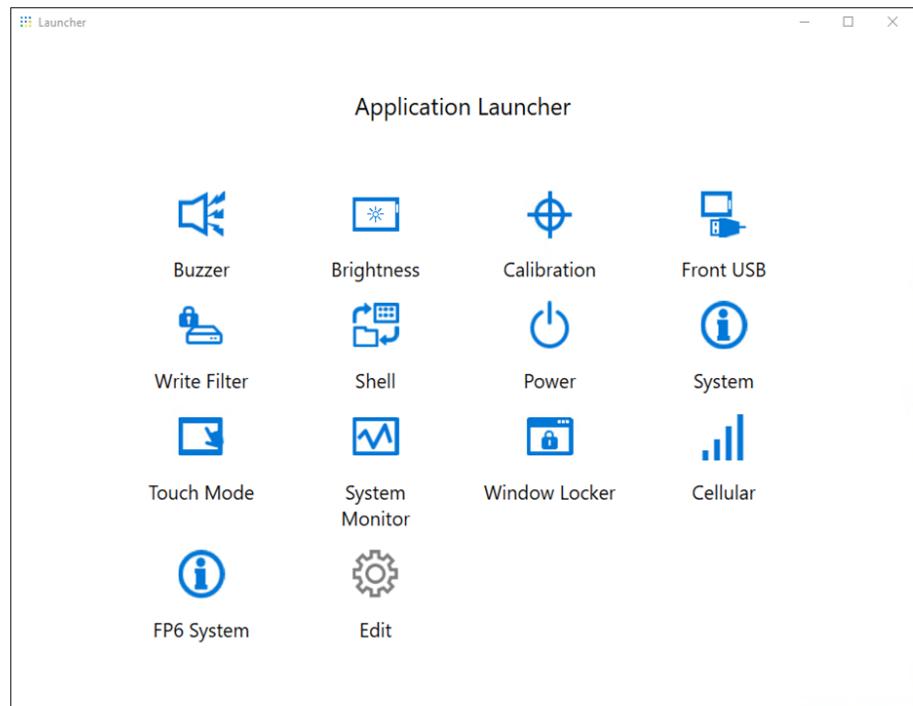

**NOTE:**

- When the Launcher is already installed on the host, the existing Launcher will be overwritten. If you used **Edit** to customize the Launcher, set up again.
- When you install this Launcher on a product that has the Launcher pre-installed, please also check the description of utilities in the manual for the host.

**Buzzer**

Turns on or off the sound that is emitted when you perform touch-panel operations.

Default: **On**

**When this product is connected to a host that is not the PS6000 Series Panel Type:**

Only the **Extend Display** icon is displayed.

**When this product is connected to the PS6000 Series Panel Type:**

An icon is displayed for each connected display. When you select an icon, the associated display flashes so you can identify which display to set up.

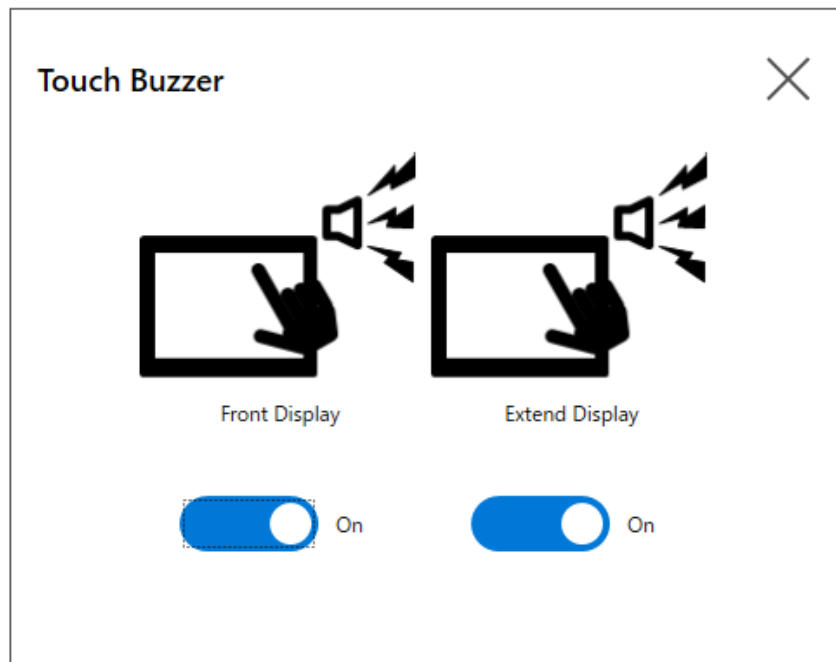

Front Display: PS6000 Series Panel Type  
Extend Display: This product

## Brightness

Sets the backlight brightness.

**When this product is connected to a host that is not the PS6000 Series Panel Type:**

Only the **Extend Display** icon is displayed.

**When this product is connected to the PS6000 Series Panel Type:**

An icon is displayed for each connected display. When you select an icon, the associated display flashes so you can identify which display to set up.

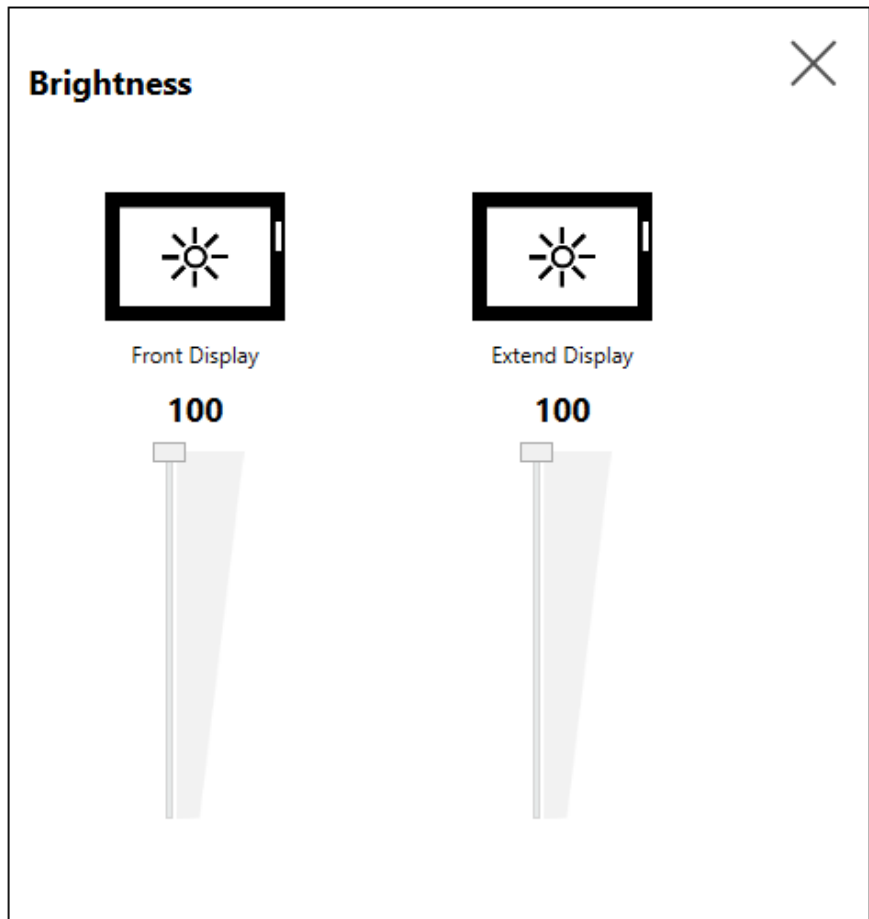

Front Display: PS6000 Series Panel Type  
Extend Display: This product

## Calibration

Calibrates the touch coordinates.

**NOTE:**

- When connecting to one of our hosts, use this utility instead of the Windows® Calibration function.
- Before running calibration, in the Windows display settings set the **Scale and layout** to 100% for the associated display. You cannot calibrate properly using other scaling settings.

When this product is connected to the PS6000 Series Panel Type, an icon for selecting the target display is displayed first. When you select an icon, the associated display flashes so you can identify which display to set up.

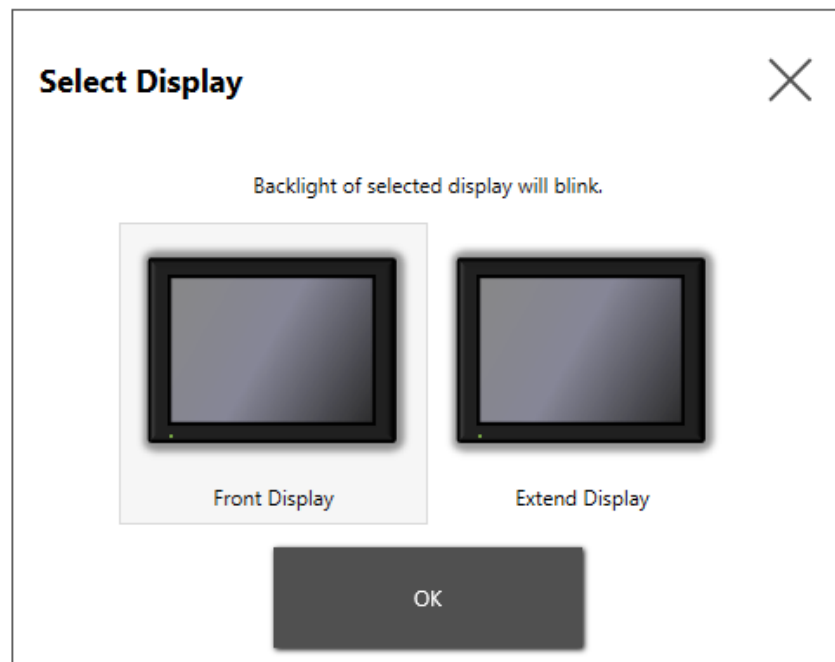

Front Display: PS6000 Series Panel Type

Extend Display: This product

Calibration screen instructions are different between analog resistive film and projected capacitive (P-CAP) displays. Perform calibration as per the screen instructions.

Analog resistive film display

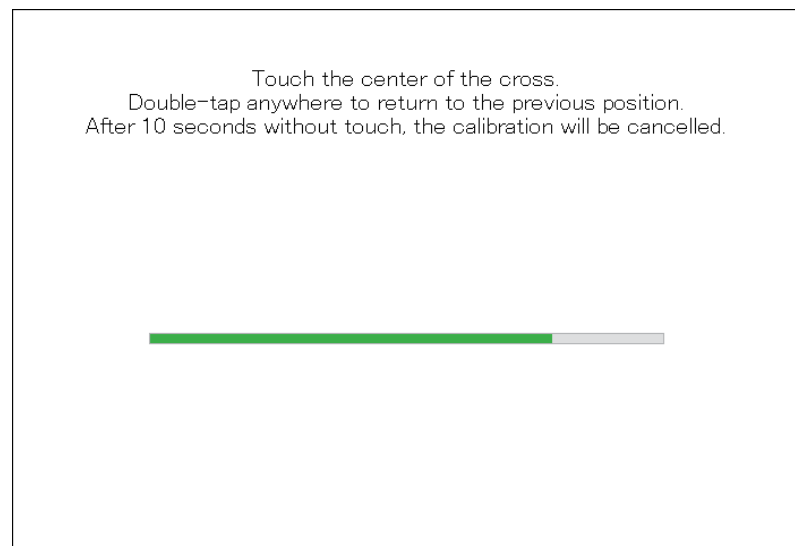

### Projected capacitive display

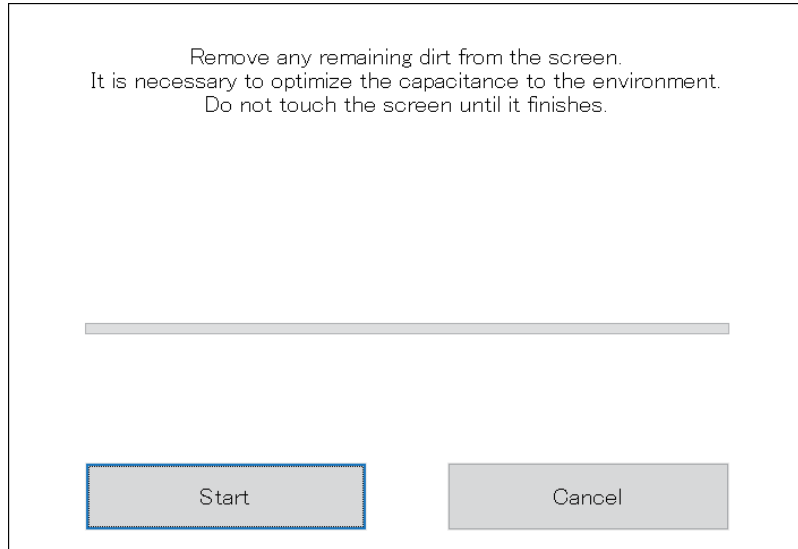

### Front USB

Enables/disables the front USB port on the Display Module.

Default: **Off** (Disable)

**When this product is connected to a host that is not the PS6000 Series Panel Type:**

Only the **Extend Display** icon is displayed.

**When this product is connected to the PS6000 Series Panel Type:**

An icon is displayed for each connected display. When you select an icon, the associated display flashes so you can identify which display to set up.

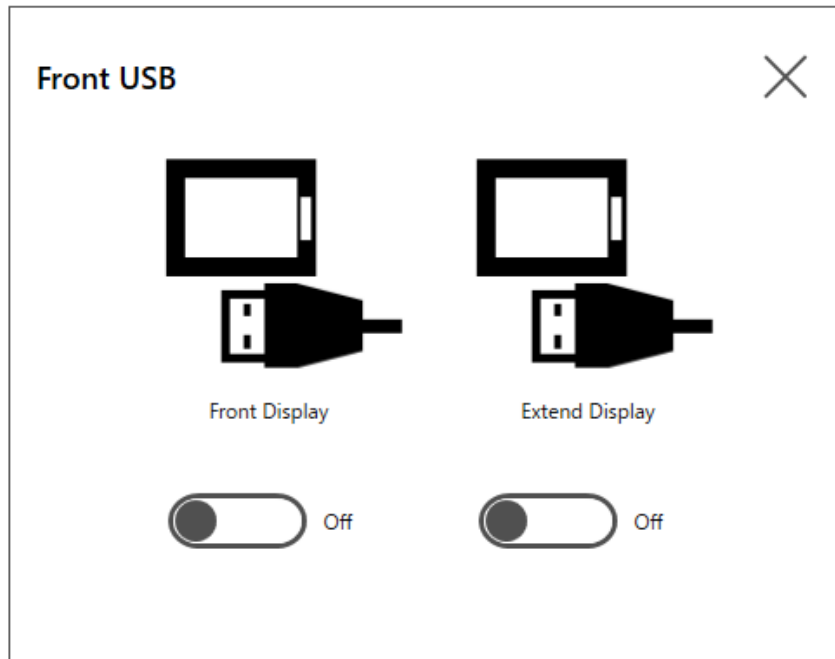

Front Display: PS6000 Series Panel Type

Extend Display: This product

**NOTE:**

- If the front USB is enabled, the risk of unauthorized access and infection of malicious software increases. Disable the front USB after use.
- In models without a front USB port, this setting is disabled.

**Touch Mode**

Change the touch mode.

**NOTE:** This function is available only on the models with a projected capacitive touch panel.

When this product is connected to the PS6000 Series Panel Type, an icon for selecting the target display is displayed first. When you select an icon, the associated display flashes so you can identify which display to set up.

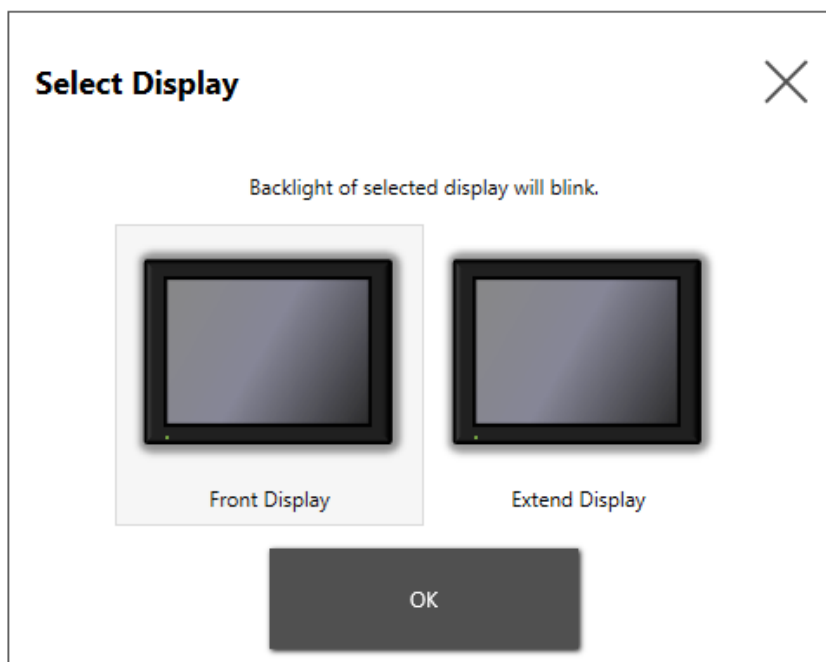

Front Display: PS6000 Series Panel Type

Extend Display: This product

The following three modes are available to support your usage environment. Select the mode according to your usage environment.

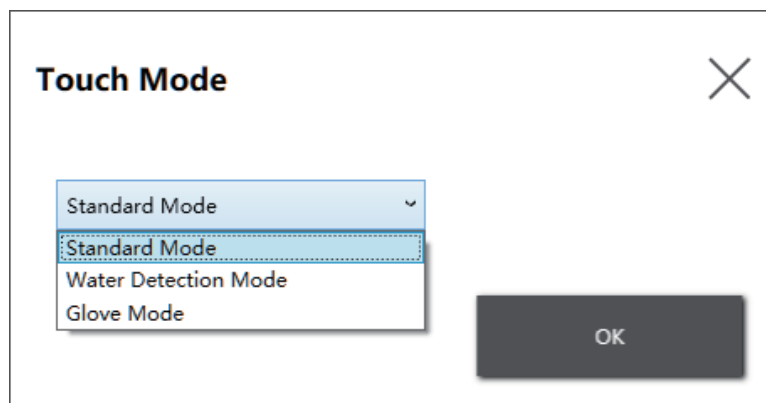

Standard Mode	Factory default. Suitable for touch operations using your finger.
Water Detection Mode	Mode where touch input becomes disabled when there are liquids, such as drops of water, on the screen. Suitable to prevent touch panel mis-operation due to liquids on the screen. After wiping the liquid or other foreign substance from the screen, touch input becomes enabled in about 2 seconds.
Glove Mode	Mode suitable for use with gloves, such as rubber gloves. <b>NOTE:</b> <ul style="list-style-type: none"> <li>Depending on the type of glove, operation may not be possible.</li> <li>Because touch sensitivity is increased in this mode, it is more susceptible to environmental noise.</li> </ul>

## FP6 System

Displays the version of the utility and firmware for the display.

When this product is connected to the PS6000 Series Panel Type, an icon for selecting the target display is displayed first. When you select an icon, the associated display flashes so you can identify which display to confirm the version.

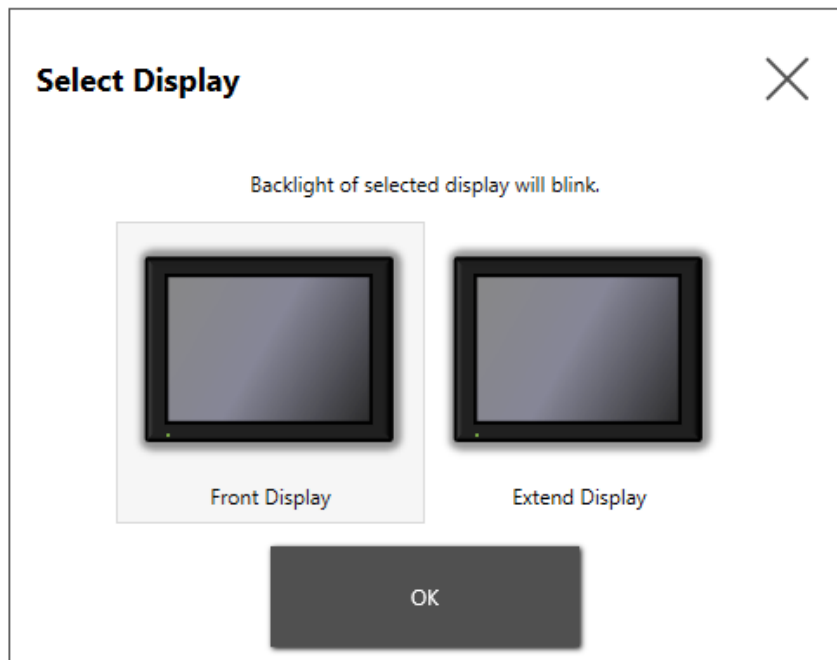

Front Display: PS6000 Series Panel Type  
 Extend Display: This product

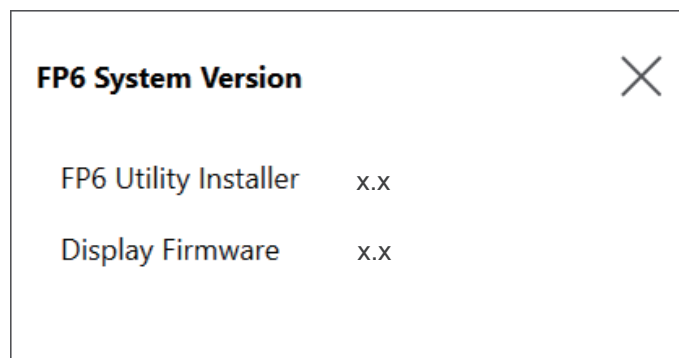

## Edit

You can use this function to customize the icons displayed on the Launcher. You can also add any application to the display.

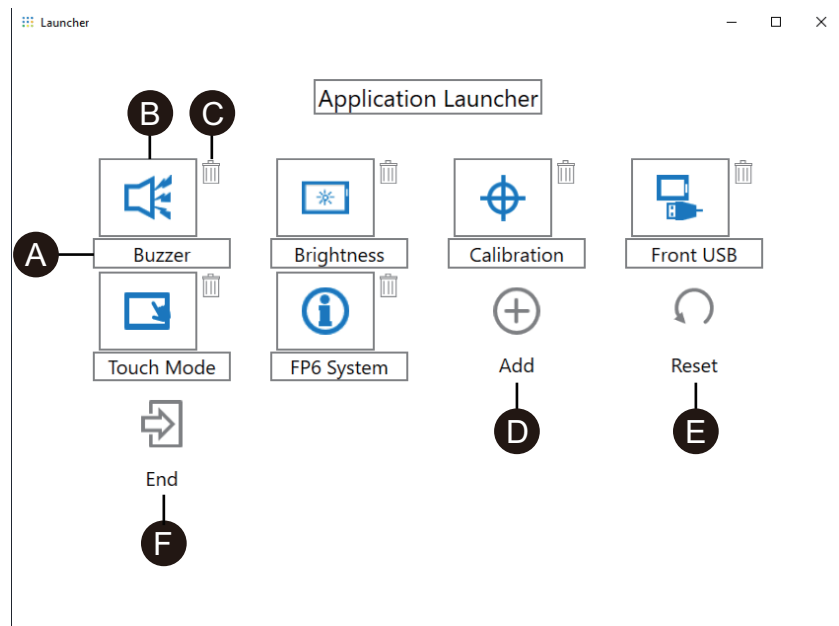

- A. You can change the name of the icon.
- B. You can change the application displayed. Click to display a screen where you can select the application's exe file. Select the exe file of the application you want to display.

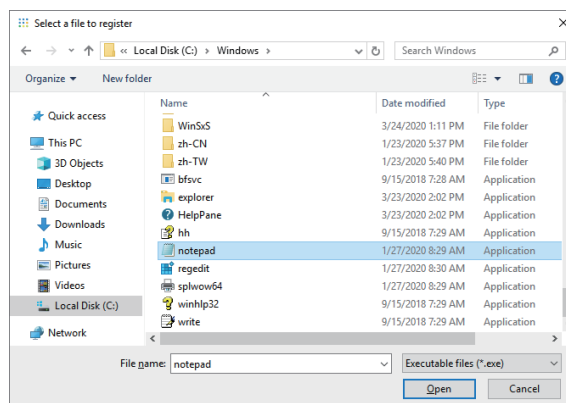

- C. Click this mark to remove the icon.
- D. Add the application displayed. Click to display a screen where you can select the application's exe file. Select the exe file of the application you want to display.
- E. Returns the icon display to the factory default settings.
- F. This button releases Edit mode.





Schneider Electric Japan Holdings Ltd.  
Schneider Electric Osaka Building, 4-4-9 Kitahama,  
541-0041 Chuo-ku, Osaka  
Japan

+81 (0) 6 6208 3133

[www.pro-face.com](http://www.pro-face.com)

As standards, specifications, and design change from time to time,  
please ask for confirmation of the information given in this publication.

© 2021 – Schneider Electric Japan Holdings Ltd. All rights reserved.

FP6000-MM01-EN\_00