



MODBUS SLAVE Device Driver

1	System Configuration.....	3
2	Selection of External Device	10
3	Example of Communication Setting.....	11
4	Setup Items	19
5	Cable Diagram	30
6	Supported Device.....	54
7	Device Code and Address Code.....	56
8	Error Messages	57
9	Command Format	58

Introduction

This manual describes how to connect the Display and the External Device.

In this manual, the connection procedure will be described by following the below sections:

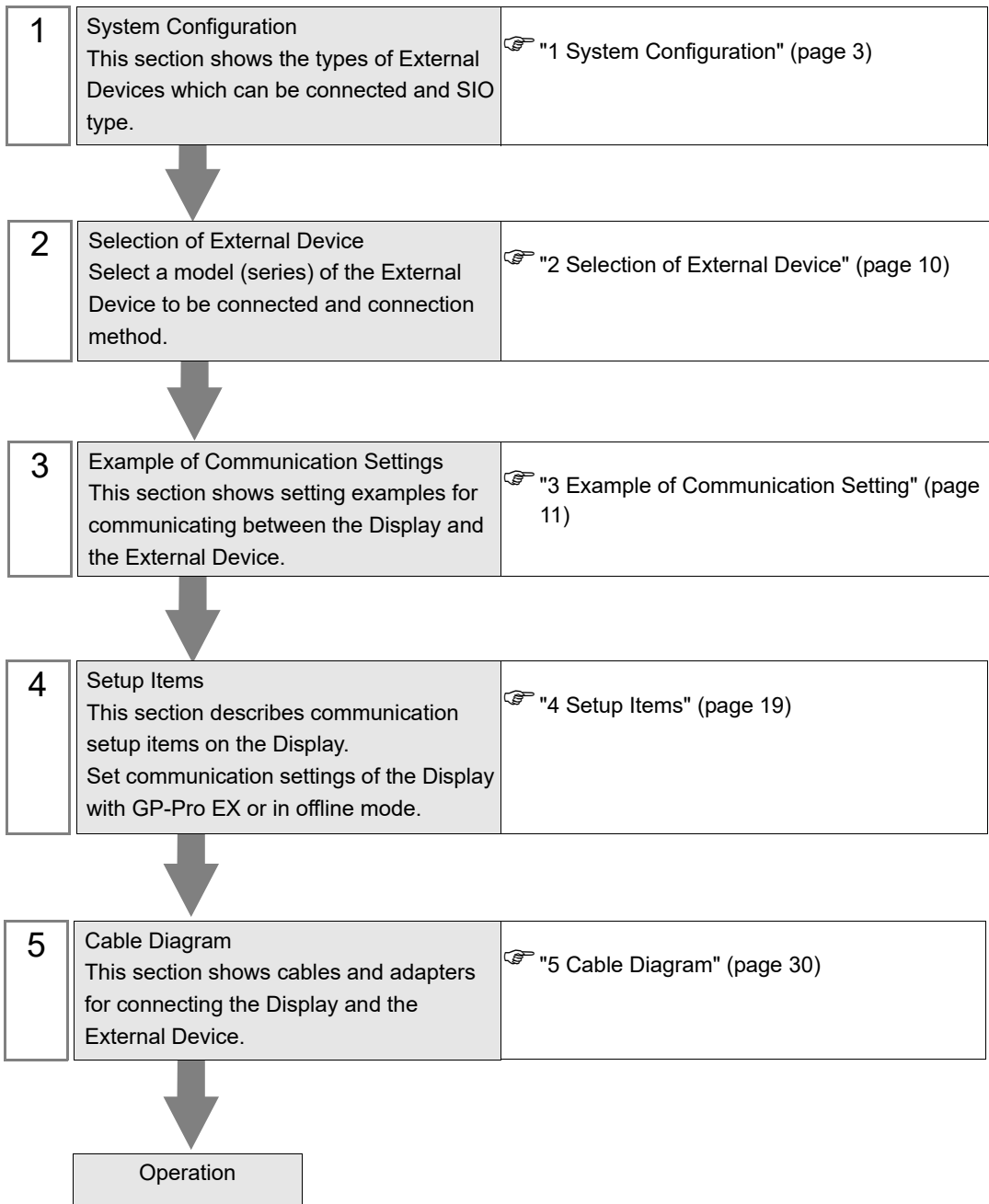

1 System Configuration

The system configuration in the case when the External Device and the Display are connected is shown.

■ Serial

Series	CPU	Link I/F	SIO Type	Setting Example	Cable Diagram
MODBUS Series	MODBUS Master Type	Serial Port	RS422/485 (2wire)	"3.1 Setting Example 1" (page 11)	"5.1 Cable Diagram 1" (page 30)
			RS232C	"3.2 Setting Example 2" (page 13)	"5.2 Cable Diagram 2" (page 43)
			RS422/485 (4wire)	"3.3 Setting Example 3" (page 15)	"5.3 Cable Diagram 3" (page 46)

■ Ethernet (TCP)

Series	CPU	Link I/F	SIO Type	Setting Example
MODBUS Series	MODBUS Master Type	Ethernet Port	Ethernet (TCP)	"3.4 Setting Example 4" (page 17)

■ Connection Configuration

◆ Serial

-
- NOTE**
- When using this driver at a communication speed of 38400 or more, there are the following limitations as listed below.
 - The DH-485 driver of Rockwell Automation, Inc. cannot be used simultaneously.
 - SIMATIC S7 MPI direct driver of Siemens AG cannot be used simultaneously.
 - This driver (communication speed: 38400 or more) cannot be used with both COM1 and COM2.
 - When this driver is used, the execution time of the logic function in the Display may be longer.
 - When using this driver on the ST6000 Series, you cannot use a communication speed of 2400.
-

- Connection example 1:1



- Connection example n:1

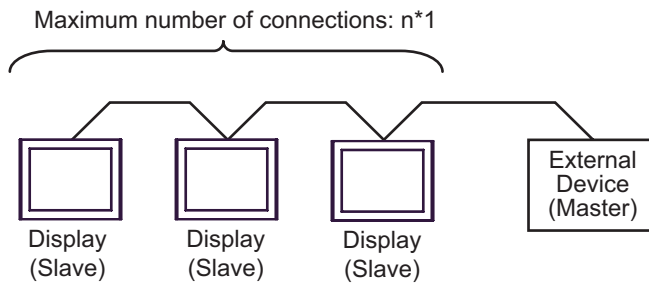

- *1 The number of Displays (Slaves) you can connect depends on the External Device. Check the specifications of the External Device.

-
- NOTE**
- When LT-4*01TM / LT-Rear Module is included in the connection configuration, Polarization resistance of the LT-4*01TM / LT-Rear Module is set to stabilize a signal level in the communication line. (Polarization resistance is different from terminal resistance.)
 - When one LT-4*01TM / LT-Rear Module is used, set "560" (default).
 - When two or more LT-4*01TM / LT-Rear Modules are used, set "560" (default) for one of the LT-4*01TM / LT-Rear Module and set "None" for the other.
 - Polarization resistance can be set in offline mode only. To display the setup screen, touch [Device/PLC Adjust] of the [Peripheral Settings] tab in the offline mode.
-

◆ Ethernet (TCP)

- NOTE**
- When the execution time of the logic function in the Display is long, a response from a master device to a request may be delayed. Adjust the time-out time of the master device when access is made from two or more master devices simultaneously.
 - When there is no communication between the Display and External Device for 100 minutes, the Display will close the connection. To re-establish communication, open the connection from the External Device.

- Connection example 1:1

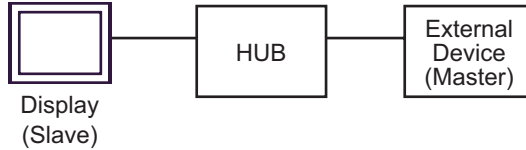

- Connection example n:1

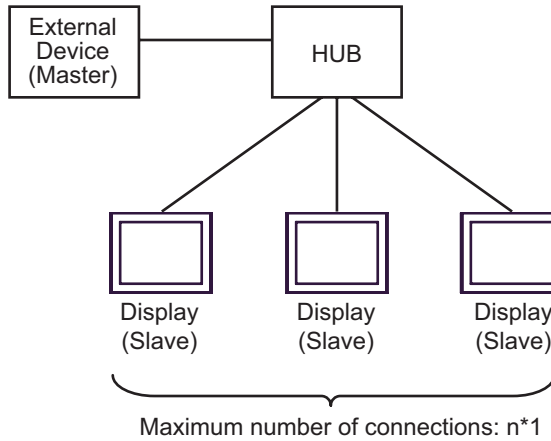

*1 The number of Displays (Slaves) you can connect depends on the External Device. Check the specifications of the External Device.

- Connection example 1:m

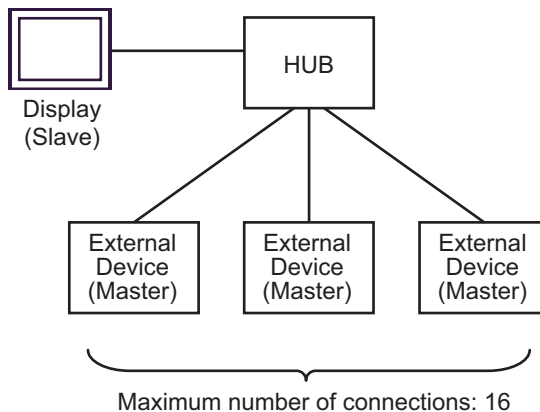

- Connection example n:m

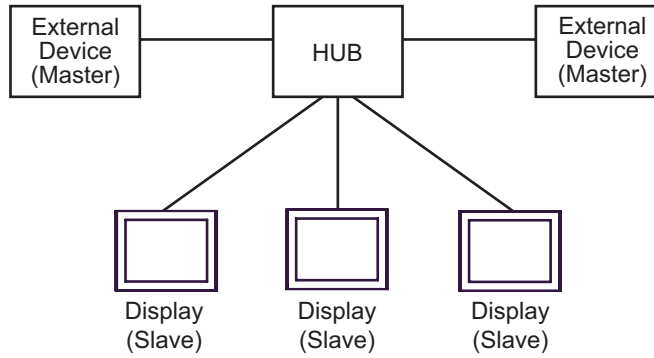

You can connect maximum 16 units of External Device (Master). Note that there is no communication between the Displays (Slaves).

■ IPC COM Port

When connecting IPC with an External Device, the COM port used depends on the series and SIO type. Please refer to the IPC manual for details.

Usable port

Series	Usable Port		
	RS-232C	RS-422/485(4 wire)	RS-422/485(2 wire)
PS-2000B	COM1 ^{*1} , COM2, COM3 ^{*1} , COM4	-	-
PS-3450A, PS-3451A, PS3000-BA, PS3001-BD	COM1, COM2 ^{*1*2}	COM2 ^{*1*2}	COM2 ^{*1*2}
PS-3650A (T41 model), PS-3651A (T41 model)	COM1 ^{*1}	-	-
PS-3650A (T42 model), PS-3651A (T42 model)	COM1 ^{*1*2} , COM2	COM1 ^{*1*2}	COM1 ^{*1*2}
PS-3700A (Pentium®4-M) PS-3710A	COM1 ^{*1} , COM2 ^{*1} , COM3 ^{*2} , COM4	COM3 ^{*2}	COM3 ^{*2}
PS-3711A	COM1 ^{*1} , COM2 ^{*2}	COM2 ^{*2}	COM2 ^{*2}
PS4000 ^{*3}	COM1, COM2	-	-
PL3000	COM1 ^{*1*2} , COM2 ^{*1} , COM3, COM4	COM1 ^{*1*2}	COM1 ^{*1*2}
PE-4000B Atom N270	COM1, COM2	-	-
PE-4000B Atom N2600	COM1, COM2	COM3 ^{*4} , COM4 ^{*4} , COM5 ^{*4} , COM6 ^{*4}	COM3 ^{*4} , COM4 ^{*4} , COM5 ^{*4} , COM6 ^{*4}
PS5000 (Slim Panel Type Core i3 Model) ^{*5*6}	COM1, COM2 ^{*4}	COM2 ^{*4}	COM2 ^{*4}
PS5000 (Slim Panel Type Atom Model) ^{*5*6}	COM1, COM2 ^{*7}	COM2 ^{*7}	COM2 ^{*7}
PS5000 (Enclosed Panel Type) ^{*8}	COM1	-	-
PS5000 (Modular Type PFXPU/PFXPP) ^{*5*6} PS5000 (Modular Type PFXPL2B5-6)	COM1 ^{*7}	COM1 ^{*7}	COM1 ^{*7}
PS5000 (Modular Type PFXPL2B1-4)	COM1, COM2 ^{*7}	COM2 ^{*7}	COM2 ^{*7}
PS6000	COM1 ^{*9}	^{*10}	^{*10}

*1 The RI/5V can be switched. Use the IPC's switch to change if necessary.

*2 Set up the SIO type with the DIP Switch. Please set up as follows according to SIO type to be used.

*3 When making communication between an External Device and COM port on the Expansion slot, only RS-232C is supported. However, ER (DTR/CTS) control cannot be executed because of the specification of COM port.

For connection with External Device, use user-created cables and disable Pin Nos. 1, 4, 6 and 9. Please refer to the IPC manual for details of pin layout.

*4 Set up the SIO type with the BIOS. Please refer to the IPC manual for details of BIOS.

- *5 When setting up communication between an External Device and the RS-232C/422/485 interface module, use the IPC (RS-232C) or PS5000 (RS-422/485) cable diagrams. However, when using PFXZPBMPR42P2 in a RS-422/485 (4-wire) configuration with no flow control, connect 7.RTS+ and 8.CTS+, and connect 6.RTS- and 9.CTS-.
When using RS-422/485 communication with External Devices, you may need to reduce the transmission speed and increase the TX Wait time.
- *6 To use RS-422/485 communication on the RS-232C/422/485 interface module, the DIP Switch setting is required. Please refer to "Knowledge Base" (FAQs) on the support site. (<http://www.pro-face.com/trans/en/manual/1001.html>)

Settings	FAQ ID
PFXZPBMPR42P2, RS422/485 change method	FA263858
PFXZPBMPR42P2 termination resistor setting	FA263974
PFXZPBMPR44P2, RS422/485 change method	FA264087
PFXZPBMPR44P2 termination resistor setting	FA264088

- *7 Set up the SIO type with the DIP Switch. Please refer to the IPC manual for details of DIP Switch. The BOX Atom has not a switch to set the RS-232C, RS-422/485 mode. Use the BIOS for the setting.
- *8 For the connection with the External Device, on the user-created cable read as if the connector on the Display-side is a M12 A-coding 8 pin socket. The pin assignment is the same as described in the cable diagram. For the M12 A-coding connector, use PFXZPSCNM122.
- *9 In addition to COM1, you can also use the RS-232C COM port on the optional interface.
- *10 Install the optional interface in the expansion slot.

DIP Switch settings (PL3000 / PS3000 Series)

RS-232C

DIP Switch	Setting	Description
1	OFF*1	Reserved (always OFF)
2	OFF	SIO type: RS-232C
3	OFF	
4	OFF	Output mode of SD (TXD) data: Always output
5	OFF	Terminal resistance (220Ω) insertion to SD (TXD): None
6	OFF	Terminal resistance (220Ω) insertion to RD (RXD): None
7	OFF	Short-circuit of SDA (TXA) and RDA (RXA): Not available
8	OFF	Short-circuit of SDB (TXB) and RDB (RXB): Not available
9	OFF	RS (RTS) Auto control mode: Disabled
10	OFF	

*1 When using PS-3450A, PS-3451A, PS3000-BA and PS3001-BD, turn ON the set value.

RS-422/485 (4 wire)

DIP Switch	Setting	Description
1	OFF	Reserved (always OFF)
2	ON	SIO type: RS-422/485
3	ON	
4	OFF	Output mode of SD (TXD) data: Always output
5	OFF	Terminal resistance (220Ω) insertion to SD (TXD): None
6	OFF	Terminal resistance (220Ω) insertion to RD (RXD): None
7	OFF	Short-circuit of SDA (TXA) and RDA (RXA): Not available
8	OFF	Short-circuit of SDB (TXB) and RDB (RXB): Not available
9	OFF* ¹	RS (RTS) Auto control mode: Disabled
10	OFF* ¹	

*1 When the connection configuration is a n:l connection, turn ON the set value.

RS-422/485 (2 wire)

DIP Switch	Setting	Description
1	OFF	Reserved (always OFF)
2	ON	SIO type: RS-422/485
3	ON	
4	OFF	Output mode of SD (TXD) data: Always output
5	OFF	Terminal resistance (220Ω) insertion to SD (TXD): None
6	OFF	Terminal resistance (220Ω) insertion to RD (RXD): None
7	ON	Short-circuit of SDA (TXA) and RDA (RXA): Available
8	ON	Short-circuit of SDB (TXB) and RDB (RXB): Available
9	ON	RS (RTS) Auto control mode: Enabled
10	ON	

2 Selection of External Device

Select the External Device to be connected to the Display.

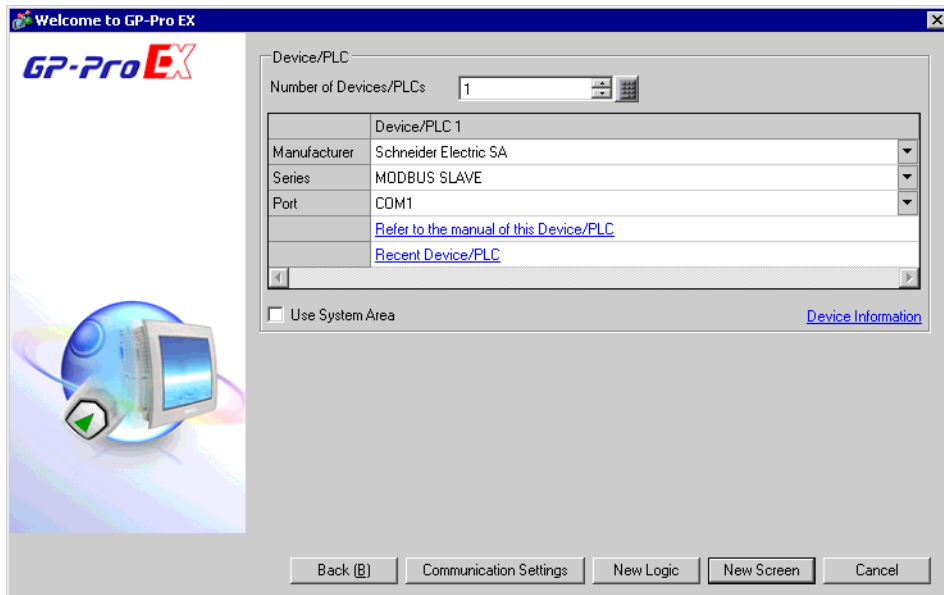

Setup Items	Setup Description
Number of Devices/PLCs	Enter an integer from 1 to 4 to define the number of Devices/PLCs to connect to the display.
Manufacturer	Select the manufacturer of the External Device to connect. Select "Schneider Electric SA".
Series	Select the External Device model (series) and the connection method. Select "MODBUS SLAVE". In System configuration, make sure the External Device you are connecting is supported by "MODBUS SLAVE". ☞ "1 System Configuration" (page 3)
Port	Select the Display port to connect to the External Device.
Use System Area	Check this option to synchronize the system data area of the Display and the device (memory) of the External Device. When synchronized, you can use the External Device's ladder program to switch the display or display the window on the Display. Cf. GP-Pro EX Reference Manual "LS Area (Direct Access Method Area)" This feature can also be set in GP-Pro EX or in the Display's offline mode. Cf. GP-Pro EX Reference Manual "System Settings [Display Unit] - [System Area] Settings Guide" Cf. Maintenance/Troubleshooting Guide "Main Unit - System Area Settings"

3 Example of Communication Setting

Examples of communication settings of the Display and the External Device, recommended by Pro-face, are shown.

3.1 Setting Example 1

■ Setting of GP-Pro EX

◆ Communication Settings

To display the setup screen, from the [Project] menu, point to [System Settings] and select [Device/PLC].

Device/PLC 1

Summary [Change Device/PLC](#)

Manufacturer Series Port

Text Data Mode [Change](#)

Communication Settings

SIO Type RS232C RS422/485(2wire) RS422/485(4wire)

Speed

Data Length 7 8

Parity NONE EVEN ODD

Stop Bit 1 2

Flow Control NONE ER(DTR/CTS) XON/XOFF

Wait To Send (ms) Default Value

Equipment Address

Slave Equipment Address

RI / VCC RI VCC

In the case of RS232C, you can select the 9th pin to RI (Input) or VCC (5V Power Supply). If you use the Digital's RS232C Isolation Unit, please select it to VCC.

Device-Specific Settings

Allowable Number of Devices/PLCs [Add Device](#)

No.	Device Name	Settings	Add Indirect Device
<input type="button" value="1"/>	<input type="text" value="PLC1"/>	<input type="text" value="Rest of the bits in this word=Do not clear.IEC61131 Sy"/>	<input type="button" value="Add Indirect Device"/>

◆ Device Setting

To display the [Individual Device Settings] dialog box, from [Device-Specific Settings] in the [Device/PLC] window, select the external device and click [Settings] .

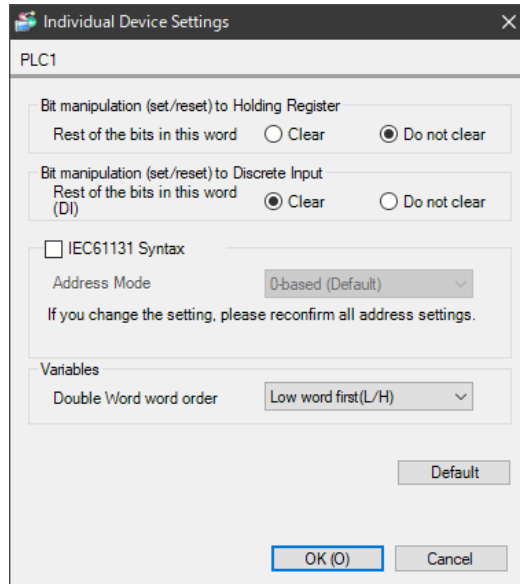

■ Settings of External Device

The communication settings depend on the External Device (Master) to be used. Please refer to the manual of the External Device for more details.

◆ Procedure

1. Set the communication settings of the External Device (Master) as follows.

Setup Items	Setup Description
Transmission Speed	19200
Data Length	8
With/Without Parity	ON
Parity Bit	EVEN
Stop Bit	1
Flow Control	NONE
Wait To Send	3 or more
Address Mode	Modicon

NOTE • Keep a gap of 3.5 characters or more between packets.

3.2 Setting Example 2

■ Setting of GP-Pro EX

◆ Communication Settings

To display the setup screen, from the [Project] menu, point to [System Settings] and select [Device/PLC].

Device/PLC 1

Summary [Change Device/PLC](#)

Manufacturer Series Port

Text Data Mode [Change](#)

Communication Settings

SIO Type RS232C RS422/485(2wire) RS422/485(4wire)

Speed

Data Length 7 8

Parity NONE EVEN ODD

Stop Bit 1 2

Flow Control NONE ER(DTR/CTS) XON/XOFF

Wait To Send (ms) Default Value

Equipment Address

Slave Equipment Address

RI / VCC RI VCC

In the case of RS232C, you can select the 9th pin to RI (Input or VCC (5V Power Supply)). If you use the Digital's RS232C Isolation Unit, please select it to VCC.

Device-Specific Settings

Allowable Number of Devices/PLCs [Add Device](#)

No.	Device Name	Settings	Add Indirect Device
<input type="button" value="v"/>	1	<input type="text" value="PLC1"/>	<input type="button" value="f"/>
		<input type="text" value="Rest of the bits in this word=Do not clear.IEC61131 Sy"/>	

◆ Device Setting

To display the [Individual Device Settings] dialog box, from [Device-Specific Settings] in the [Device/PLC] window, select the external device and click [Settings] .

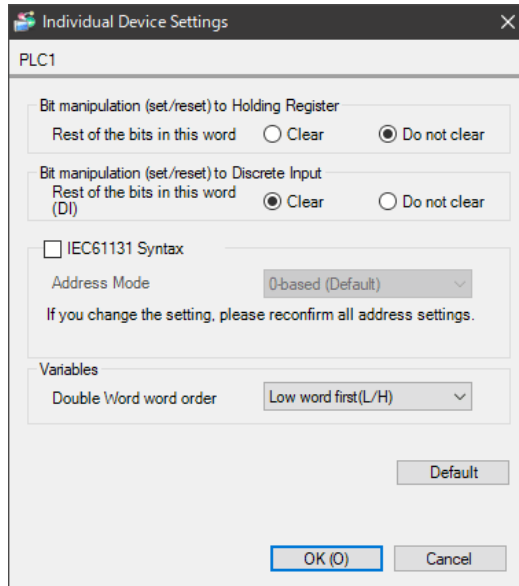

■ Settings of External Device

The communication settings depend on the External Device (Master) to be used. Please refer to the manual of the External Device for more details.

◆ Procedure

1. Set the communication settings of the External Device (Master) as follows.

Setup Items	Setup Description
Transmission Speed	19200
Data Length	8
With/Without Parity	ON
Parity Bit	EVEN
Stop Bit	1
Flow Control	NONE
Wait To Send	3 or more
Address Mode	Modicon

NOTE • Keep a gap of 3.5 characters or more between packets.

3.3 Setting Example 3

■ Setting of GP-Pro EX

◆ Communication Settings

To display the setup screen, from the [Project] menu, point to [System Settings] and select [Device/PLC].

Device/PLC 1

Summary [Change Device/PLC](#)

Manufacturer Series Port

Text Data Mode [Change](#)

Communication Settings

SIO Type RS232C RS422/485(2wire) RS422/485(4wire)

Speed

Data Length 7 8

Parity NONE EVEN ODD

Stop Bit 1 2

Flow Control NONE ER(DTR/CTS) XON/XOFF

Wait To Send (ms) Default Value

Equipment Address

Slave Equipment Address

RI / VCC RI VCC

In the case of RS232C, you can select the 9th pin to RI (Input) or VCC (5V Power Supply). If you use the Digital's RS232C Isolation Unit, please select it to VCC.

Device-Specific Settings

Allowable Number of Devices/PLCs [Add Device](#)

No.	Device Name	Settings	Add Indirect Device
<input type="button" value="1"/>	<input type="text" value="PLC1"/>	<input type="text" value="Rest of the bits in this word=Do not clear.IEC61131 Sy"/>	<input type="button" value="Add Indirect Device"/>

◆ Device Setting

To display the [Individual Device Settings] dialog box, from [Device-Specific Settings] in the [Device/PLC] window, select the external device and click [Settings] .

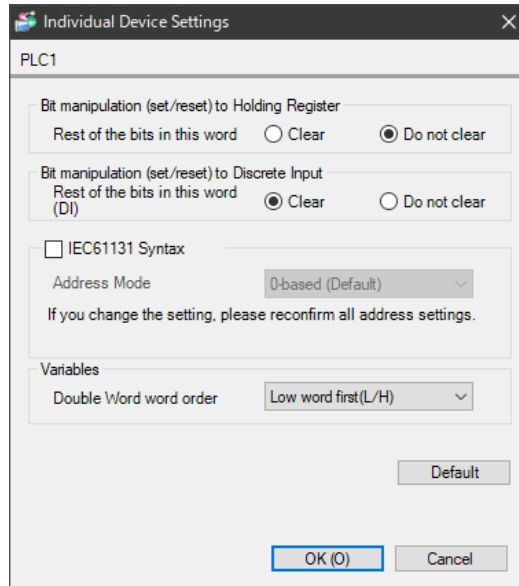

■ Settings of External Device

The communication settings depend on the External Device (Master) to be used. Please refer to the manual of the External Device for more details.

◆ Procedure

1. Set the communication settings of the External Device (Master) as follows.

Setup Items	Setup Description
Transmission Speed	19200
Data Length	8
With/Without Parity	ON
Parity Bit	EVEN
Stop Bit	1
Flow Control	NONE
Wait To Send	3 or more
Address Mode	Modicon

NOTE • Keep a gap of 3.5 characters or more between packets.

3.4 Setting Example 4

■ Setting of GP-Pro EX

◆ Communication Settings

To display the setup screen, from the [Project] menu, point to [System Settings] and select [Device/PLC].

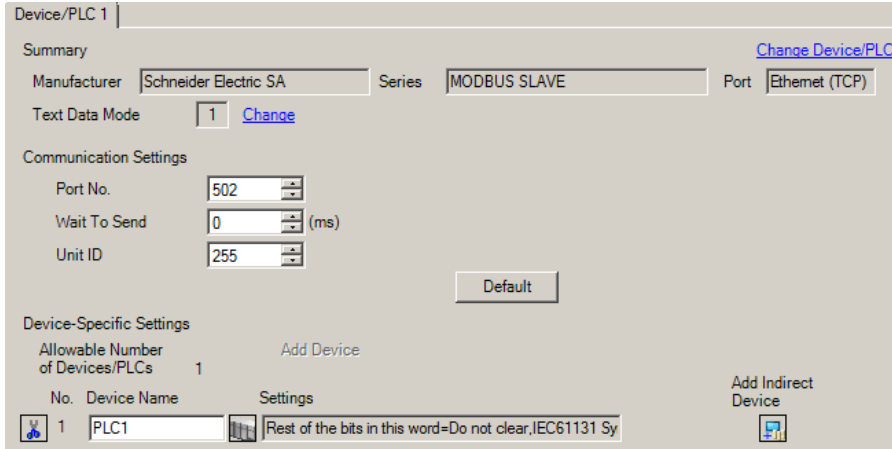

◆ Device Setting

To display the [Individual Device Settings] dialog box, from [Device-Specific Settings] in the [Device/PLC] window, select the external device and click [Settings] .

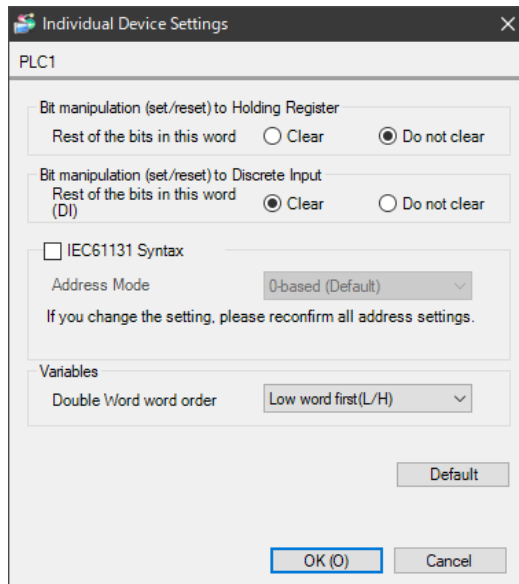

■ Settings of External Device

The communication settings depend on the External Device (Master) to be used. Please refer to the manual of the External Device for more details.

◆ Procedure

1. Set the communication settings of the External Device (Master) as follows.

Setup Items	Setup Description
Wait To Send	0
Source port number	Any number
Destination port number	502
Address Mode	Modicon

4 Setup Items

Set communication settings of the Display with GP-Pro Ex or in offline mode of the Display.

The setting of each parameter must be identical to that of External Device.

 "3 Example of Communication Setting" (page 11)

NOTE • Set the Display's IP address in offline mode.

Cf. Maintenance/Troubleshooting Guide "Ethernet Settings"

4.1 Serial Connection

■ Setup Items in GP-Pro EX

◆ Communication Settings

To display the setup screen, from the [Project] menu, point to [System Settings] and select [Device/PLC].

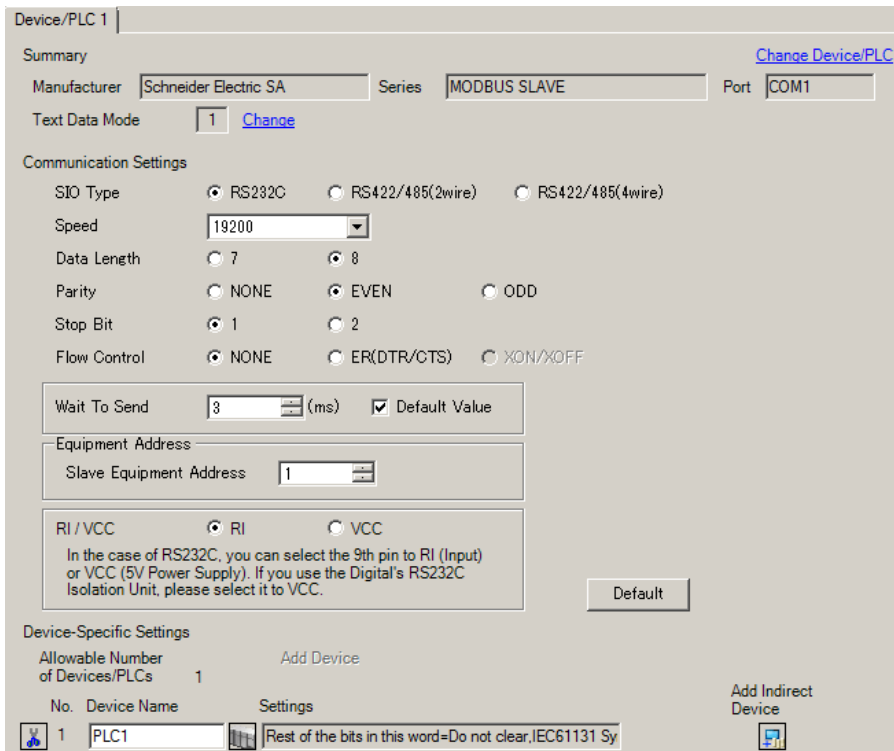

Device/PLC 1

Summary [Change Device/PLC](#)

Manufacturer Series Port

Text Data Mode [Change](#)

Communication Settings

SIO Type RS232C RS422/485(2wire) RS422/485(4wire)

Speed

Data Length 7 8

Parity NONE EVEN ODD

Stop Bit 1 2

Flow Control NONE ER(DTR/CTS) XON/XOFF

Wait To Send (ms) Default Value

Equipment Address

Slave Equipment Address

RI / VCC RI VCC

In the case of RS232C, you can select the 9th pin to RI (Input) or VCC (5V Power Supply). If you use the Digital's RS232C Isolation Unit, please select it to VCC.

Default

Device-Specific Settings

Allowable Number of Devices/PLCs [Add Device](#)

No.	Device Name	Settings
<input type="button" value="↓"/> 1	<input type="text" value="PLC1"/>	<input type="button" value="⋮"/> Rest of the bits in this word=Do not clear,IEC61131 Sy

[Add Indirect Device](#)

Setup Items	Setup Description
SIO Type	Select the SIO type to communicate with the External Device.
Speed	Select speed between the External Device and the Display.
Data Length	Select data length.
Parity	Select how to check parity.
Stop Bit	Select stop bit length.
Flow Control	Display the communication control method to prevent overflow of transmission and reception data.

Setup Items	Setup Description
Wait To Send	<p>Use an integer from "1 to 255" to enter standby time (ms) for the Display from receiving packets to transmitting next commands.</p> <p>When the check box of the default value is checked, the Wait To Send value automatically changes in the formula below by changing each value for Speed/Data Length/Parity/Stop Bit.</p> $\text{Wait To Send (ms)} = \frac{3500 \times (1 + \text{Data Length} + \text{Stop Bit} + \text{Parity})}{\text{Speed (bps)}}$ <p>Value for the parity setting is shown below. No Parity = 0 Parity Even = 1 Parity Odd = 1</p>
Slave Equipment Address	Use an integer from "1 to 247" to enter the slave address of the External Device.
RI/VCC	<p>You can switch RI/VCC of the 9th pin when you select RS232C for SIO type.</p> <p>It is necessary to change RI/5V by changeover switch of IPC when connect with IPC.</p> <p>Please refer to the manual of the IPC for more detail.</p>

NOTE • Refer to the GP-Pro EX Reference Manual for Indirect Device.

Cf. GP-Pro EX Reference Manual "Changing the Device/PLC at Runtime (Indirect Device)"

◆ Device Setting

To display the [Individual Device Settings] dialog box, from [Device-Specific Settings] in the [Device/PLC] window, select the external device and click [Settings] .

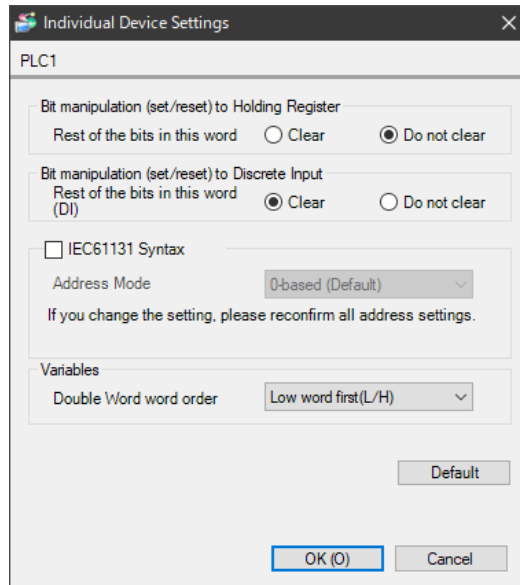

Setup Items	Setup Description
Bit manipulation (set/reset) to Holding Register	From "Clear" or "Do not clear", select treatment of the rest of the bits in the same word when the bit manipulation to Holding Register is performed.
Bit manipulation (set/reset) to Discrete Input	From "Clear" or "Do not clear", select treatment of the rest of the bits in the same word when the bit manipulation to Discrete Input is performed.
IEC61131 Syntax	Check this item when you use the IEC61131 grammar for variables.
Address Mode	If you check the IEC61131 Syntax check box, select the address mode from "0-based" or "1-based".
Double Word word order	Select the order of storing double word data from "Low word first" or "High word first".

■ Settings in Offline Mode

NOTE

- Please refer to Maintenance/Troubleshooting guide for more information on how to enter offline mode or about operation.

Cf. Maintenance/Troubleshooting Guide "Offline Mode"

- The number of the setup items to be displayed for 1 page in the offline mode depends on the Display in use. Please refer to the Reference manual for details.

◆ Communication Settings

To display the setting screen, touch [Device/PLC Settings] from [Peripheral Settings] in the offline mode. Touch the External Device you want to set from the displayed list.

Comm.	Device	Option		
MODBUS SLAVE		[COM1]		Page 1/1
SIO Type		RS232C		
Speed		19200		
Data Length		<input type="radio"/> 7 <input checked="" type="radio"/> 8		
Parity		<input type="radio"/> NONE <input checked="" type="radio"/> EVEN <input type="radio"/> ODD		
Stop Bit		<input checked="" type="radio"/> 1 <input type="radio"/> 2		
Flow Control		NONE		
Wait To Send(ms)		3		
Slave Address		1		
	Exit		Back	2015/11/06 10:37:08

Setup Items	Setup Description
SIO Type	<p>Select the SIO type to communicate with the External Device.</p> <p>IMPORTANT</p> <p>To make the communication settings correctly, confirm the serial interface specifications of Display unit for [SIO Type]. We cannot guarantee the operation if a communication type that the serial interface does not support is specified. For details concerning the serial interface specifications, refer to the manual for Display unit.</p>
Speed	Select speed between the External Device and the Display.
Data Length	Select data length.
Parity	Select how to check parity.
Stop Bit	Select stop bit length.

Setup Items	Setup Description
Flow Control	Display the communication control method to prevent overflow of transmission and reception data.
Wait To Send	<p>Use an integer from "1 to 255" to enter standby time (ms) for the Display from receiving packets to transmitting next commands. After changing the values of Speed/Data Length/Parity/Stop Bit, set the Wait To Send value using the following formula.</p> $\text{Wait To Send (ms)} = \frac{3500 \times (1 + \text{Data Length} + \text{Stop Bit} + \text{Parity})}{\text{Speed (bps)}}$ <p>Value for the parity setting is shown below. No Parity = 0 Parity Even = 1 Parity Odd = 1</p>
Slave Address	Use an integer from "1 to 247" to enter the slave address of the External Device.

◆ Device Setting

To display the setting screen, touch [Device/PLC Settings] from [Peripheral Settings]. Touch the External Device you want to set from the displayed list, and touch [Device Settings].

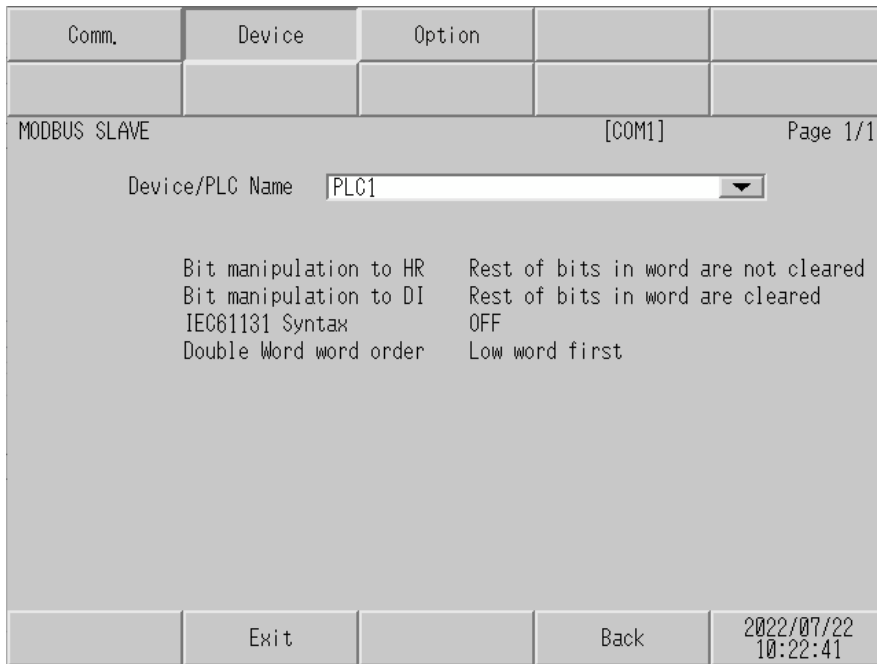

Setup Items	Setup Description
Device/PLC name	Select the External Device to set. Device name is a title of the External Device set with GP-Pro EX. (Initial value [PLC])
Bit manipulation to HR	Displays how other bits in the same word are handled when you manipulate bits in the holding register, as "Rest of bits in word are cleared" or "Rest of bits in word are not cleared". (Not available to set in offline mode.)
Bit manipulation to DI	Displays how other bits in the same word are handled when you manipulate bits in the discrete input, as "Rest of bits in word are cleared" or "Rest of bits in word are not cleared". (Not available to set in offline mode.)
IEC61131 Syntax	Displays whether IEC61131 syntax is used or not.
DWord Word Order	Displays the order in which double word data is stored.

◆ Option

To display the setting screen, touch [Device/PLC Settings] from [Peripheral Settings]. Touch the External Device you want to set from the displayed list, and touch [Option].

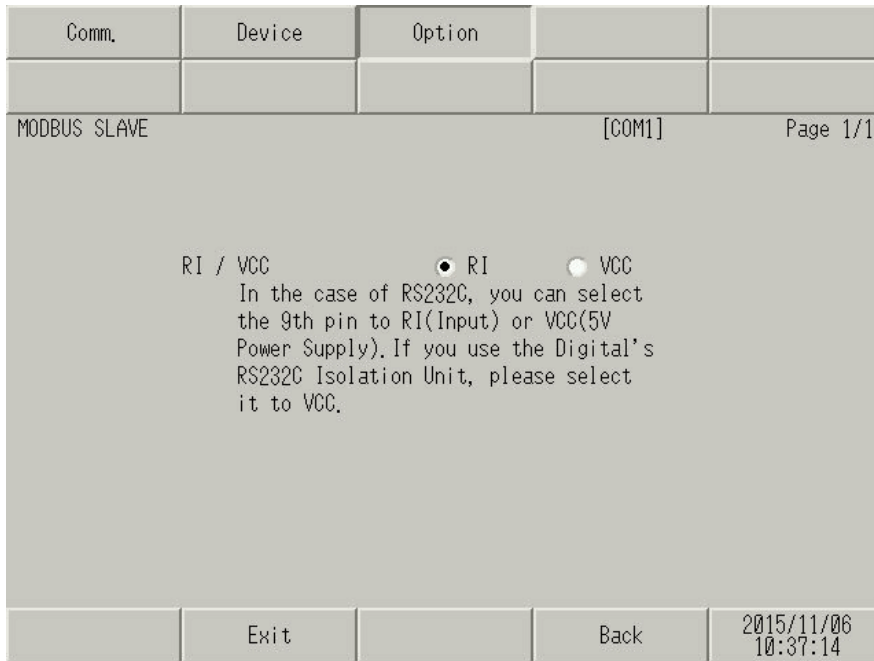

Setup Items	Setup Description
RI/VCC	Switches RI/VCC of the 9th pin. It is necessary to change RI/5V by changeover switch of IPC when connect with IPC. Please refer to the manual of the IPC for more detail.

NOTE

- GP-4100 series, GP-4*01TM, GP-Rear Module, LT-4*01TM and LT-Rear Module do not have the [Option] setting in the offline mode.

4.2 Ethernet (TCP) Connection

■ Setup Items in GP-Pro EX

◆ Communication Settings

To display the setup screen, from the [Project] menu, point to [System Settings] and select [Device/PLC].

Device/PLC 1

Summary [Change Device/PLC](#)

Manufacturer Series Port

Text Data Mode [Change](#)

Communication Settings

Port No.

Wait To Send (ms)

Unit ID

Device-Specific Settings

Allowable Number of Devices/PLCs 1 [Add Device](#)

No.	Device Name	Settings	Add Indirect Device
1	PLC1	<input type="text" value="Rest of the bits in this word=Do not clear,IEC61131 Sy"/>	<input type="button" value="Add Indirect Device"/>

Setup Items	Setup Description
Port No.	Use an integer "502" or from "1024 to 65535" to enter the port No. of the Display.
Wait To Send	Use an integer from "0 to 255" to enter standby time (ms) for the Display from receiving packets to transmitting next commands.
Unit ID	Use an integer from "1 to 247" or "255" to enter the slave address.

NOTE • Refer to the GP-Pro EX Reference Manual for Indirect Device.

Cf. GP-Pro EX Reference Manual "Changing the Device/PLC at Runtime (Indirect Device)"

◆ Device Setting

To display the [Individual Device Settings] dialog box, from [Device-Specific Settings] in the [Device/PLC] window, select the external device and click [Settings] .

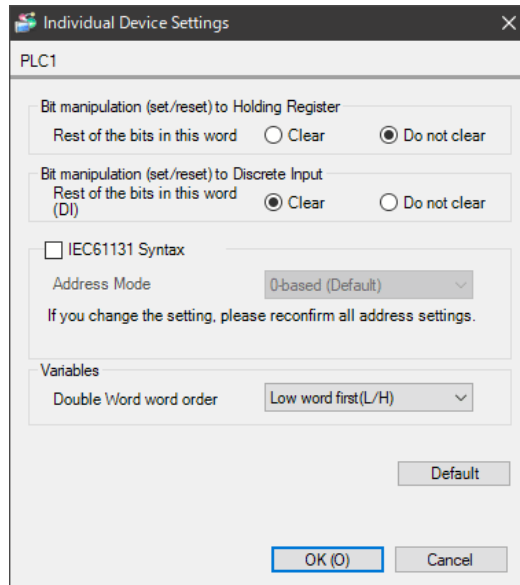

Setup Items	Setup Description
Bit manipulation (set/reset) to Holding Register	From "Clear" or "Do not clear", select treatment of the rest of the bits in the same word when the bit manipulation to Holding Register is performed.
Bit manipulation (set/reset) to Discrete Input	From "Clear" or "Do not clear", select treatment of the rest of the bits in the same word when the bit manipulation to Discrete Input is performed.
IEC61131 Syntax	Check this item when you use the IEC61131 grammar for variables.
Address Mode	If you check the IEC61131 Syntax check box, select the address mode from "0-based" or "1-based".
Double Word word order	Select the order of storing double word data from "Low word first" or "High word first".

■ Settings in Offline Mode

NOTE

- Please refer to Maintenance/Troubleshooting guide for more information on how to enter offline mode or about operation.

Cf. Maintenance/Troubleshooting Guide "Offline Mode"

- The number of the setup items to be displayed for 1 page in the offline mode depends on the Display in use. Please refer to the Reference manual for details.

◆ Communication Settings

To display the setting screen, touch [Device/PLC Settings] from [Peripheral Settings] in the offline mode. Touch the External Device you want to set from the displayed list.

Comm.	Device			
MODBUS SLAVE		[TCP]	Page 1/1	
Port No.	<input type="text" value="502"/>			
Wait To Send(ms)	<input type="text" value="0"/>			
Unit ID	<input type="text" value="255"/>			
	Exit		Back	2015/11/06 10:52:58

Setup Items	Setup Description
Port No.	Use an integer "502" or from "1024 to 65535" to enter the port No. of the Display.
Wait To Send	Use an integer from "0 to 255" to enter standby time (ms) for the Display from receiving packets to transmitting next commands.
Unit ID	Use an integer from "1 to 247" or "255" to enter the slave address.

◆ Device Setting

To display the setting screen, touch [Device/PLC Settings] from [Peripheral Settings]. Touch the External Device you want to set from the displayed list, and touch [Device Settings].

Comm.	Device			
MODBUS SLAVE		[TCP]	Page 1/1	
Device/PLC Name		PLC1 ▼		
Bit manipulation to HR		Rest of bits in word are not cleared		
Bit manipulation to DI		Rest of bits in word are cleared		
IEC61131 Syntax		OFF		
Double Word word order		Low word first		
Exit		Back		2022/07/22 10:25:35

Setup Items	Setup Description
Device/PLC name	Select the External Device to set. Device name is a title of the External Device set with GP-Pro EX. (Initial value [PLC])
Bit manipulation to HR	Displays how other bits in the same word are handled when you manipulate bits in the holding register, as "Rest of bits in word are cleared" or "Rest of bits in word are not cleared". (Not available to set in offline mode.)
Bit manipulation to DI	Displays how other bits in the same word are handled when you manipulate bits in the discrete input, as "Rest of bits in word are cleared" or "Rest of bits in word are not cleared". (Not available to set in offline mode.)
IEC61131 Syntax	Displays whether IEC61131 syntax is used or not.
DWord Word Order	Displays the order in which double word data is stored.

5 Cable Diagram

The following cable diagrams may be different from cable diagrams recommended by External Device Manufacturer.

Please be assured there is no operational problem in applying the cable diagram shown in this manual.

- The FG pin of the External Device body must be grounded according to your country's applicable standard. Refer to your External Device manual for details.
- SG and FG are connected inside the Display. When connecting the External Device to SG, design your system to avoid short-circuit loops.
- Connect an isolation unit if the communication is not stable due to noise or other factors.

5.1 Cable Diagram 1

Display (Connection Port)	Cable		Remarks
GP3000* ¹ (COM1) AGP-3302B (COM2) GP-4*01TM (COM1) GP-Rear Module (COM1) ST3000* ² (COM2) LT3000 (COM1)	1A	COM Port Conversion Adapter by Pro-face CA3-ADPCOM-01 + Terminal Block Conversion Adapter by Pro-face CA3-ADPTRM-01 + User-created cable	Cable length: 1,000m or less (Depends on master's capacity)
	1B	User-created cable	
GP3000* ³ (COM2)	1C	Online Adapter by Pro-face CA4-ADPONL-01 + Terminal Block Conversion Adapter by Pro-face CA3-ADPTRM-01 + User-created cable	Cable length: 1,000m or less (Depends on master's capacity)
	1D	Online Adapter by Pro-face CA4-ADPONL-01 + User-created cable	
IPC* ⁴	1E	COM Port Conversion Adapter by Pro-face CA3-ADPCOM-01 + Terminal Block Conversion Adapter by Pro-face CA3-ADPTRM-01 + User-created cable	Cable length: 1,000m or less (Depends on master's capacity)
	1F	User-created cable	
GP-4106 (COM1) GP-4116T (COM1)	1G	User-created cable	Cable length: 1,000m or less (Depends on master's capacity)

Display (Connection Port)	Cable		Remarks
GP-4107 (COM1) GP-4*03T* ⁵ (COM2) GP-4203T (COM1)	1H	User-created cable	Cable length: 1,000m or less (Depends on master's capacity)
GP4000* ⁶ (COM2) GP-4201T (COM1) SP5000* ⁷ (COM1/2) SP-5B00 (COM2) ST6000* ⁸ (COM2) ST-6200 (COM1)	1I	RS-422 Terminal Block Conversion Adapter by Pro-face PFXZCBADTM1 * ⁹ + User-created cable	Cable length: 1,000m or less (Depends on master's capacity)
	1B	User-created cable	
LT-4*01TM (COM1) LT-Rear Module (COM1)	1J	RJ45 RS-485 Cable (5m) by Pro-face PFXZLMCBJR81	Cable length: 200m or less (Depends on master's capacity)
PE-4000B* ¹⁰ PS5000* ¹⁰ PS6000* ¹⁰	1K	User-created cable	Cable length: 1,000m or less (Depends on master's capacity)

*1 All GP3000 models except AGP-3302B

*2 Except AST-3211A and AST-3302B

*3 All GP3000 models except GP-3200 series and AGP-3302B

*4 Only the COM port which can communicate by RS-422/485 (2 wire) can be used. (Except PE-4000B, PS5000, and PS6000)
"■ IPC COM Port" (page 7)

*5 Except GP-4203T

*6 All GP4000 models except GP-4100 series, GP-4*01TM, GP-Rear Module, GP-4201T and GP-4*03T

*7 Except SP-5B00

*8 Except ST-6200

*9 When using a Terminal Block Conversion Adapter (CA3-ADPTRM-01) instead of the RS-422 Terminal Block Conversion Adapter, refer to Cable Diagram 1A.

*10 Only the COM port which can communicate by RS-422/485 (2 wire) can be used.
"■ IPC COM Port" (page 7)

1A)

- 1:1 Connection

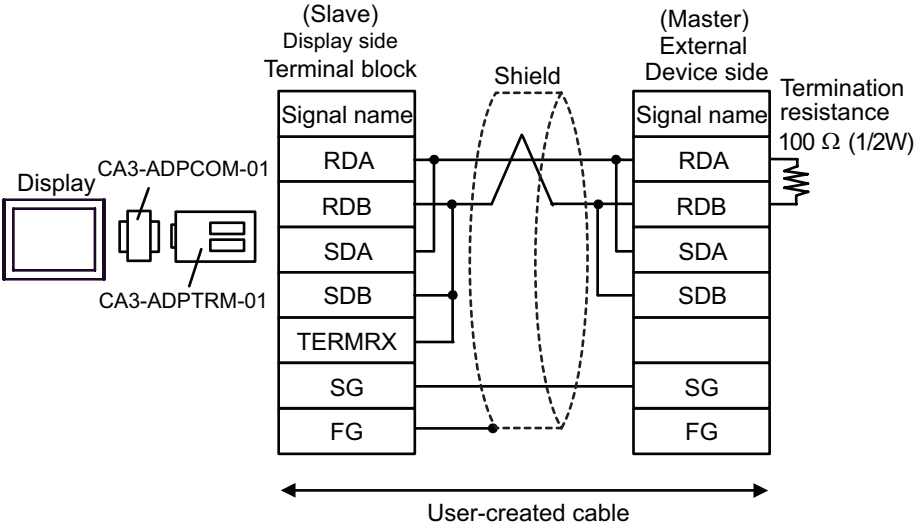

- n:1 Connection

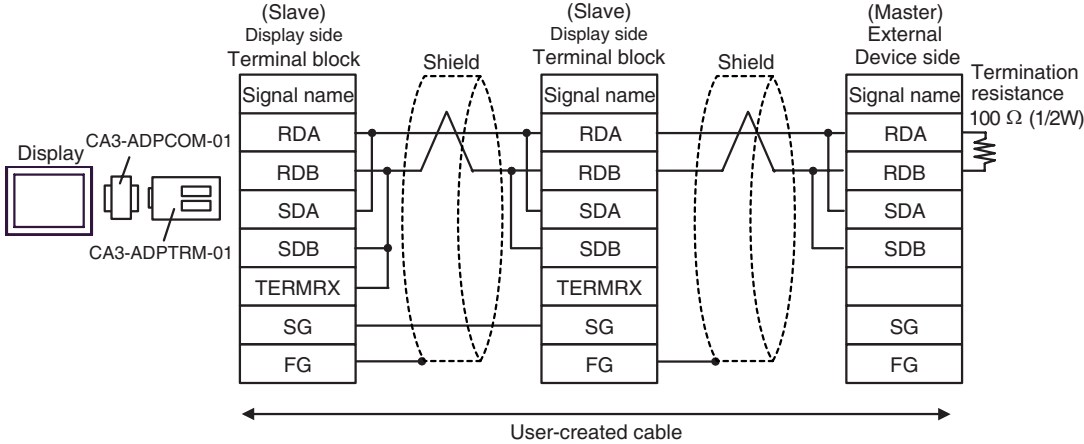

NOTE • Cable length: 1,000m or less (Depends on master's capacity)

1B)

- 1:1 Connection

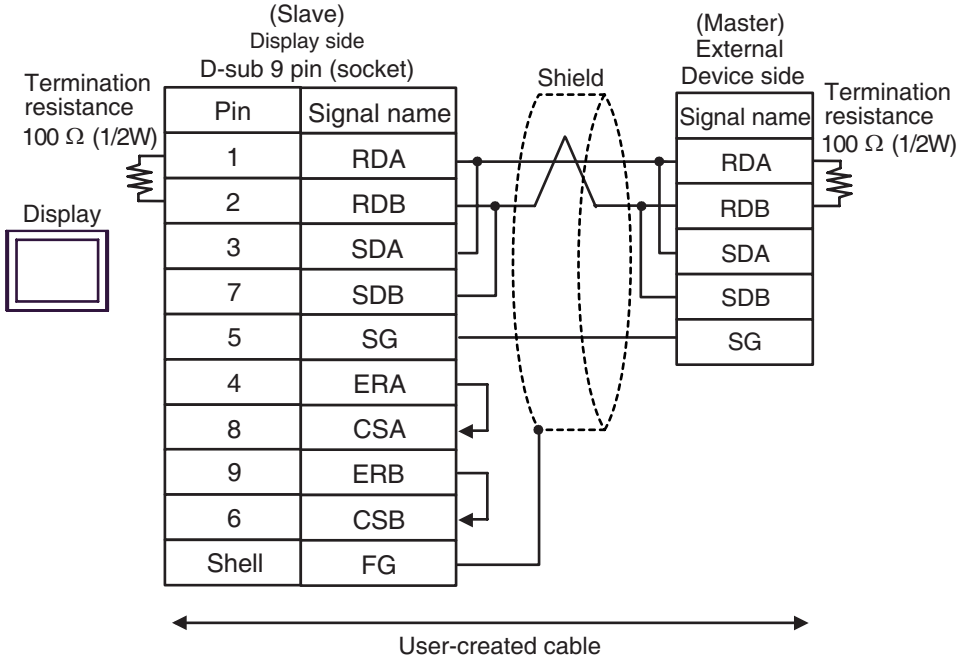

- n:1 Connection

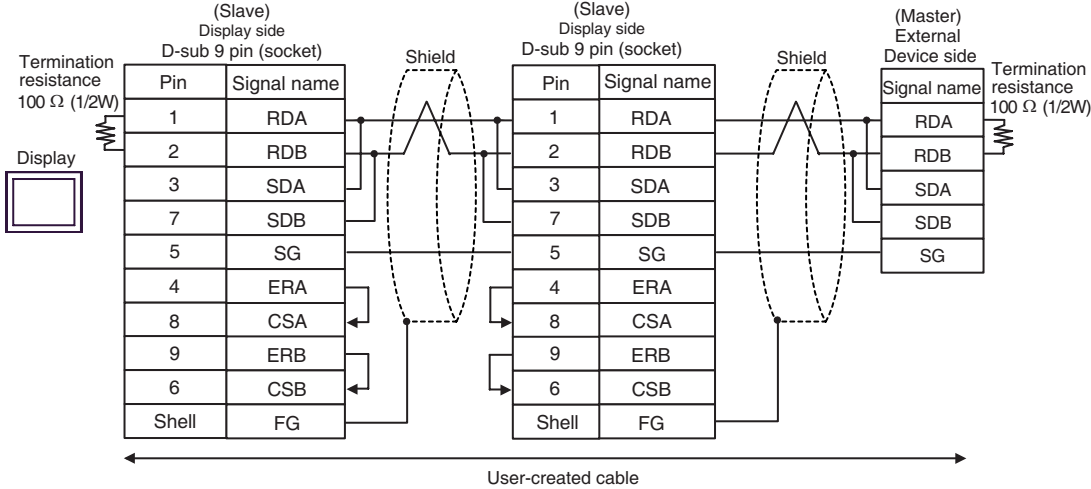

NOTE • Cable length: 1,000m or less (Depends on master's capacity)

1C)

- 1:1 Connection

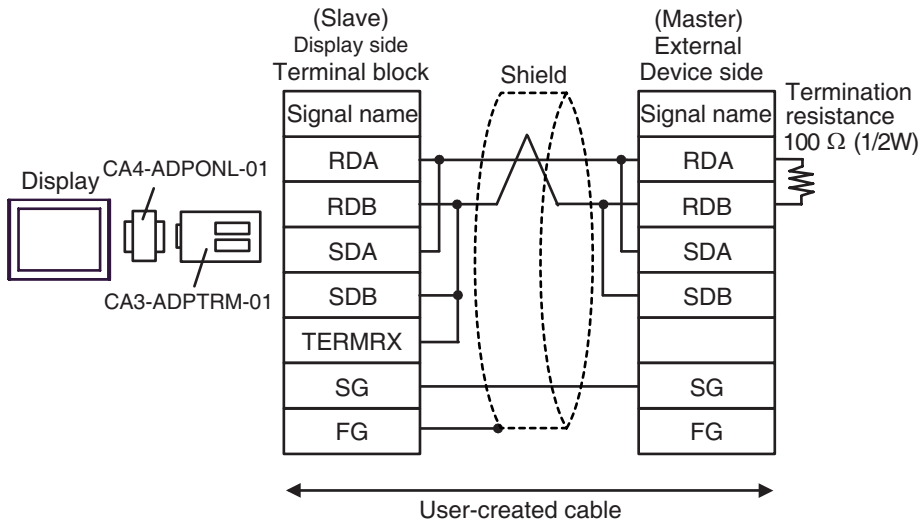

- n:1 Connection

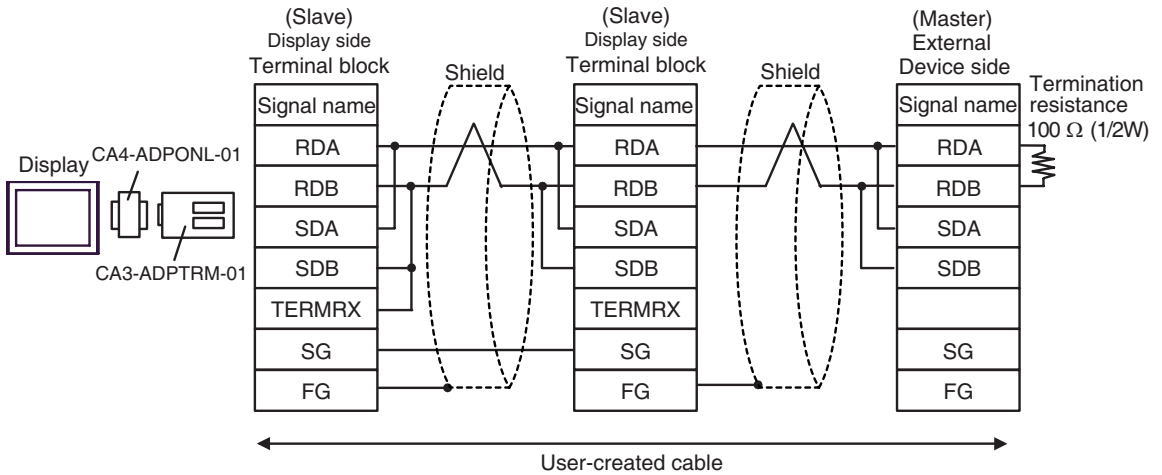

NOTE

- Cable length: 1,000m or less (Depends on master's capacity)

1D)

- 1:1 Connection

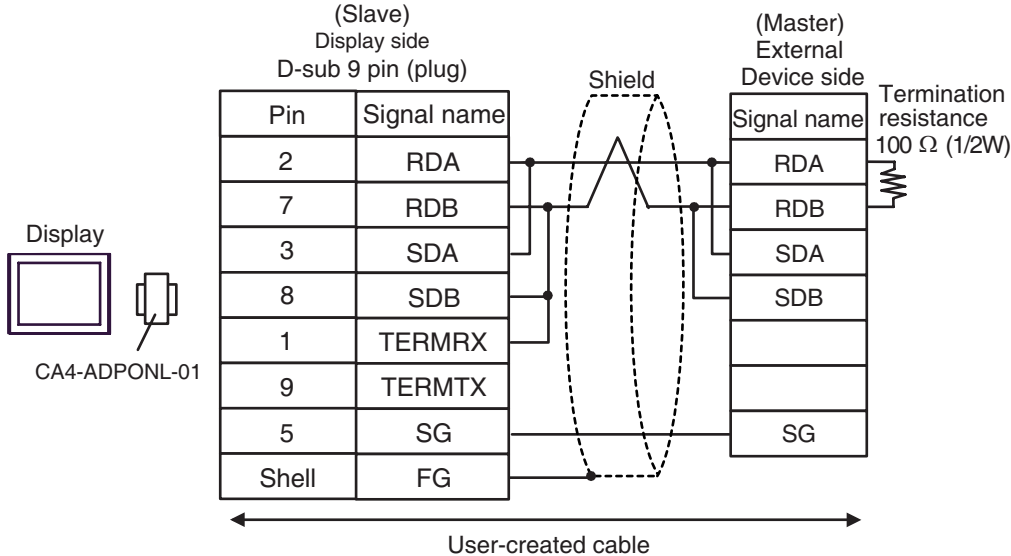

- n:1 Connection

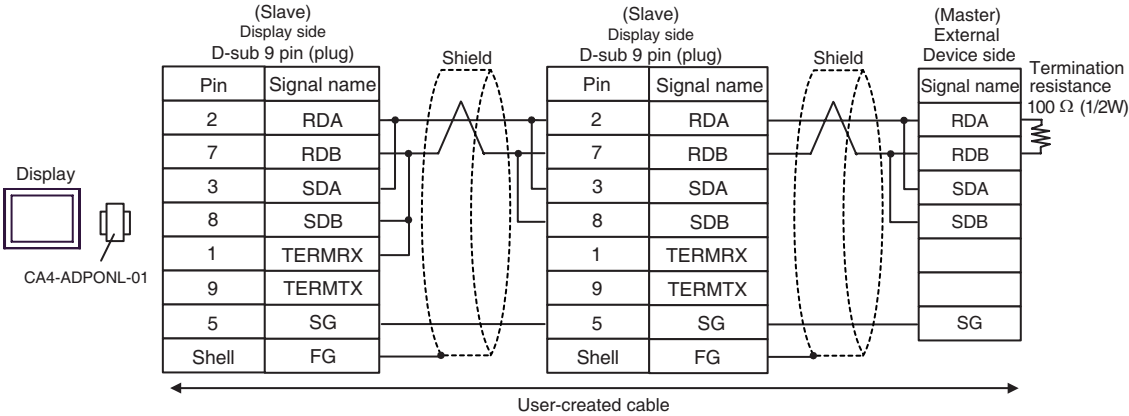

NOTE • Cable length: 1,000m or less (Depends on master's capacity)

1E)

- 1:1 Connection

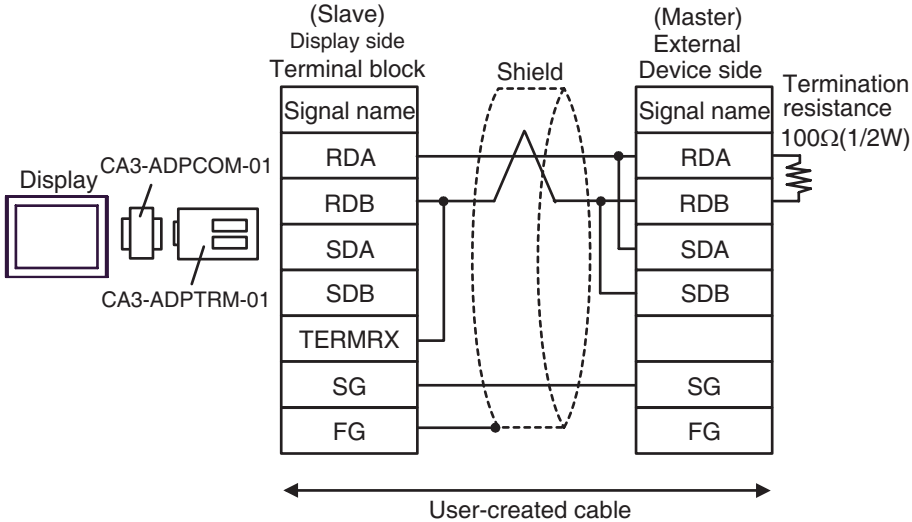

- n:1 Connection

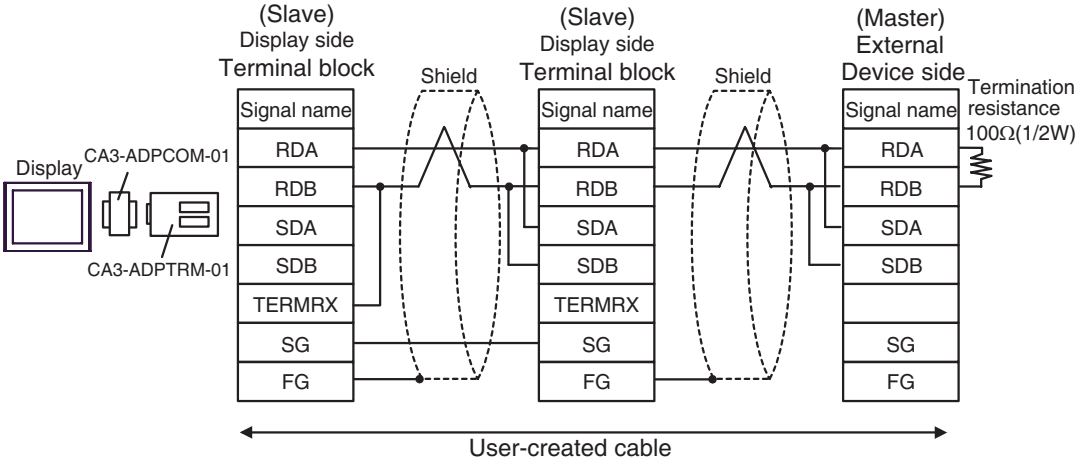

NOTE • Cable length: 1,000m or less (Depends on master's capacity)

1F)

- 1:1 Connection

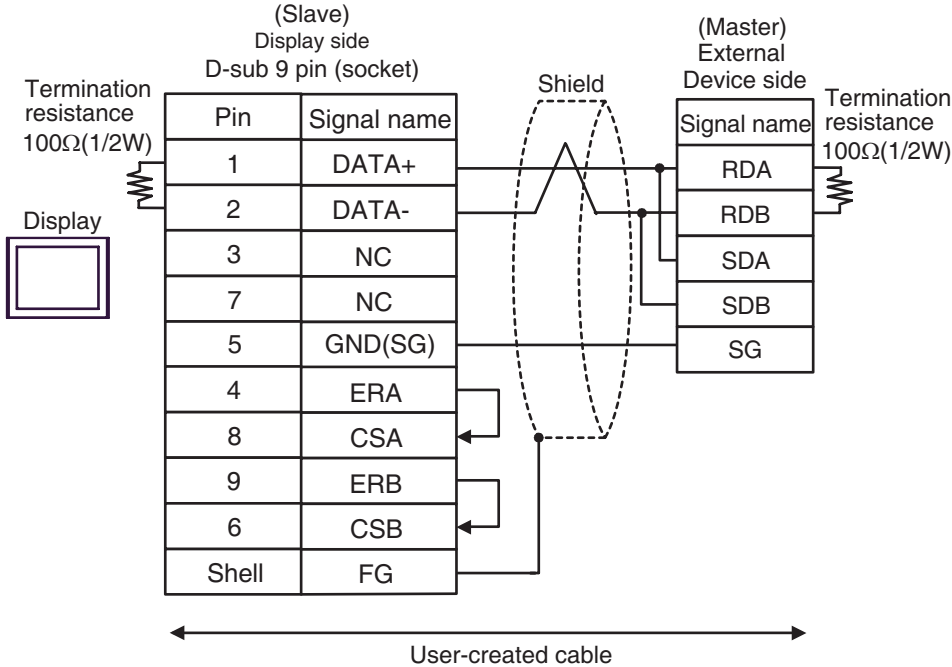

- n:1 Connection

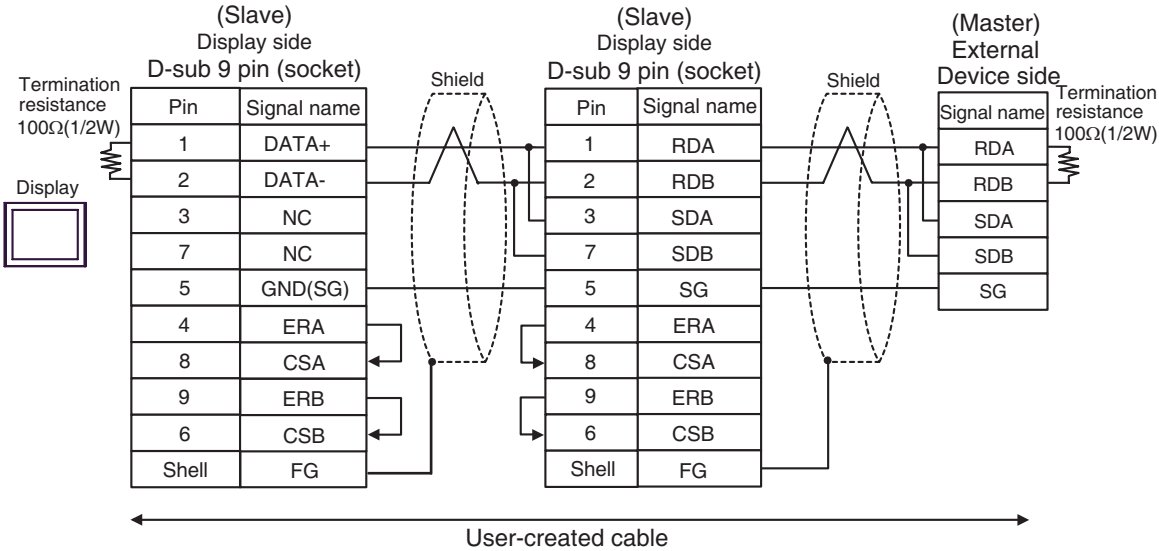

NOTE • Cable length: 1,000m or less (Depends on master's capacity)

1G)

- 1:1 Connection

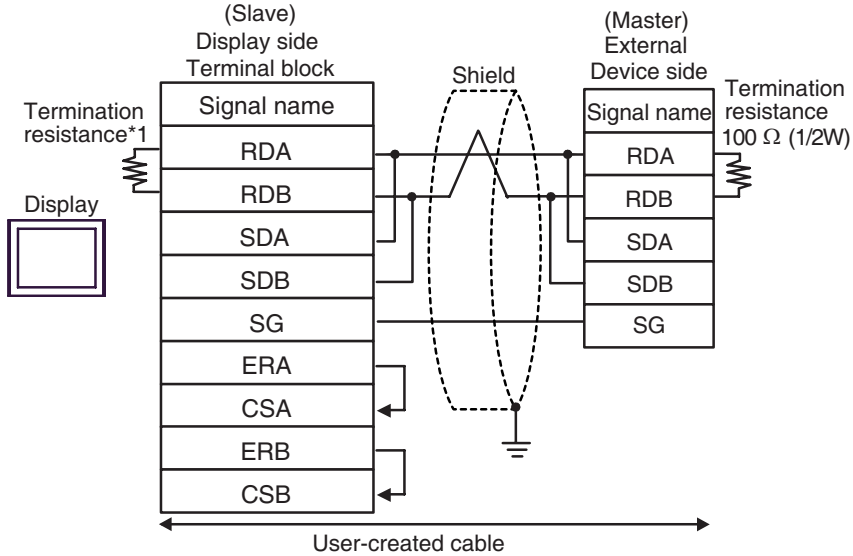

- n:1 Connection

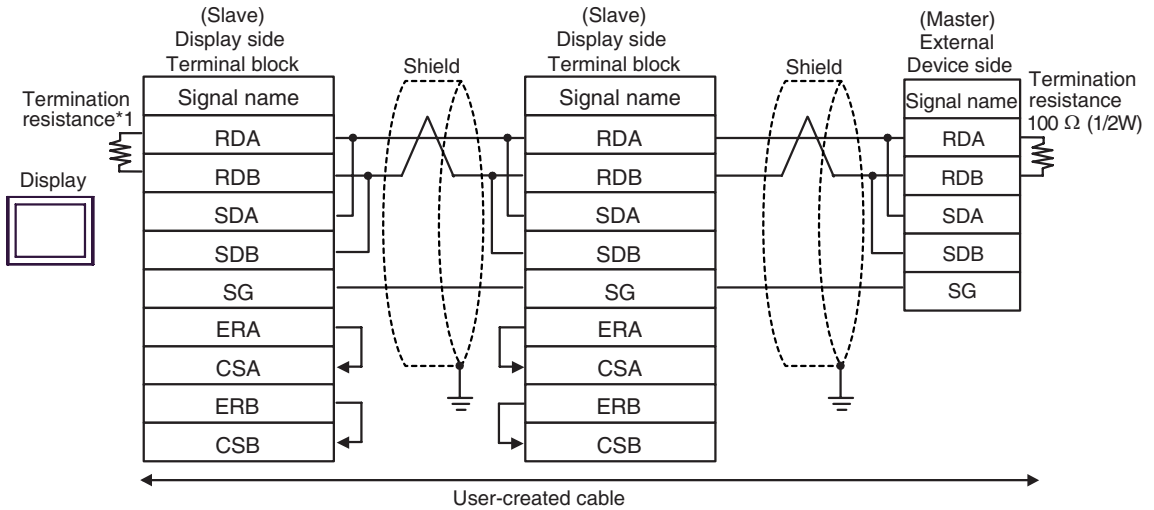

*1 The resistance in the Display is used as the termination resistance. Set the value of the DIP Switch on the rear of the Display as shown in the table below.

DIP Switch No.	Set Value
1	OFF
2	OFF
3	ON
4	ON

For the Displays other than that used as the terminal, set the DIP Switch 1-4 on the rear of the Display to OFF in the n:1 connection.

NOTE

- Cable length:1,000m or less (Depends on master's capacity)

1H)

- 1:1 Connection

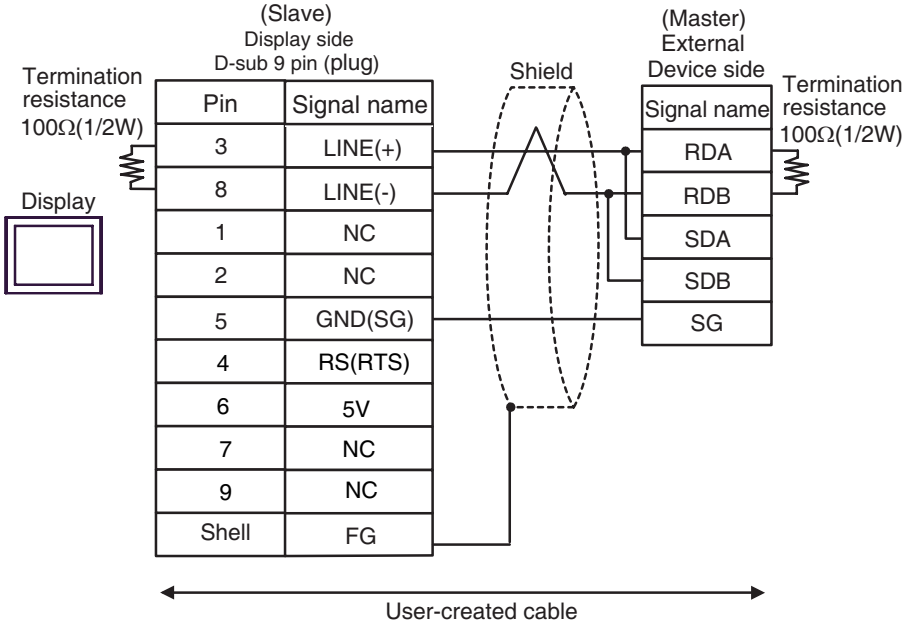

- n:1 Connection

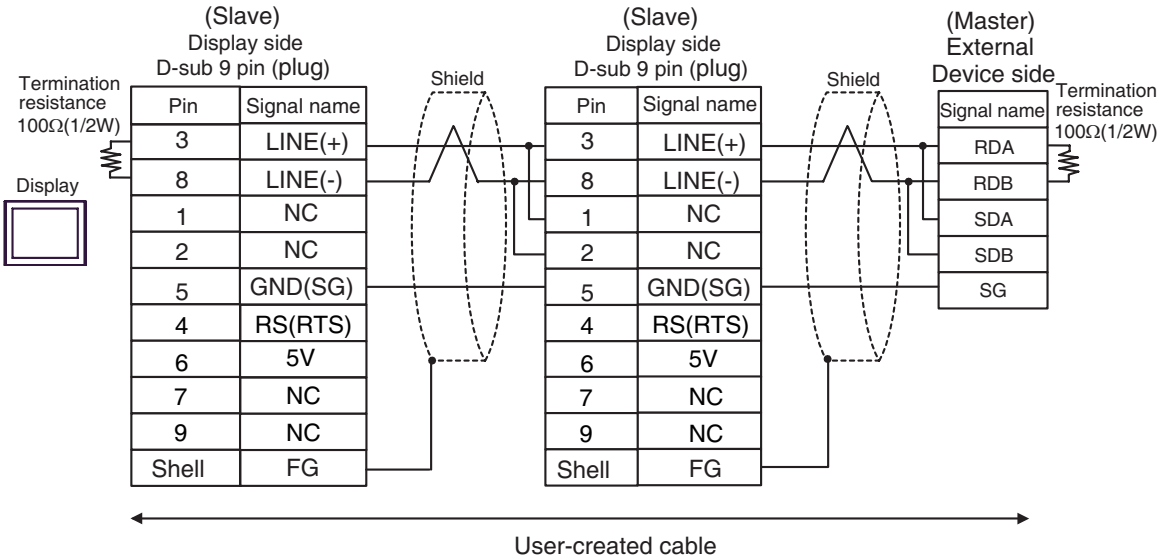

IMPORTANT

- The 5V output (Pin #6) on the Display is the power for the Siemens AG's PROFIBUS connector. Do not use it for other devices.

NOTE

- In COM on the GP-4107, the SG and FG terminals are isolated.
- Cable length: 1,000m or less (Depends on master's capacity)

1)

- 1:1 Connection

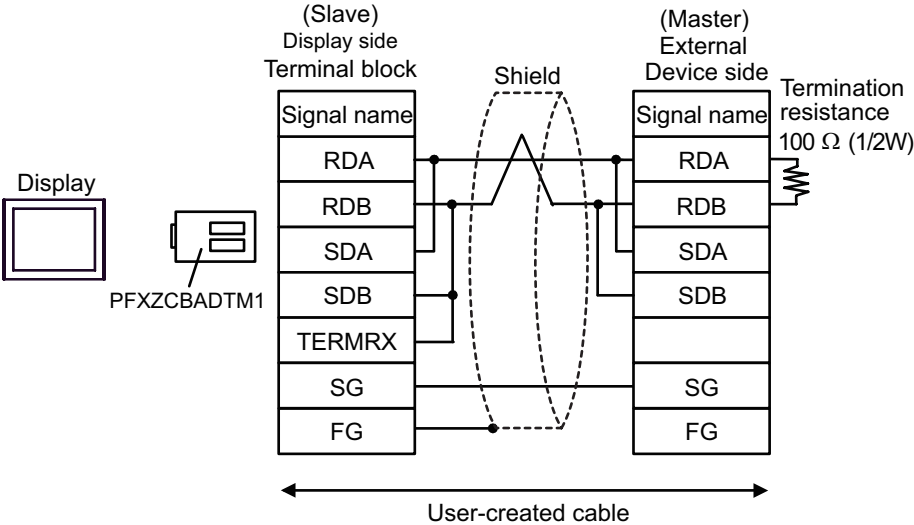

- n:1 Connection

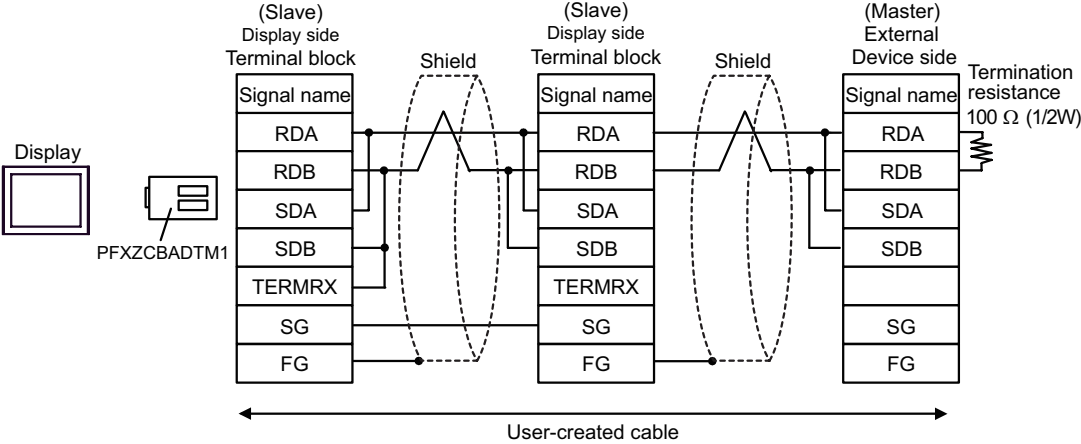

NOTE • Cable length: 1,000m or less (Depends on master's capacity)

1J)

- 1:1 Connection

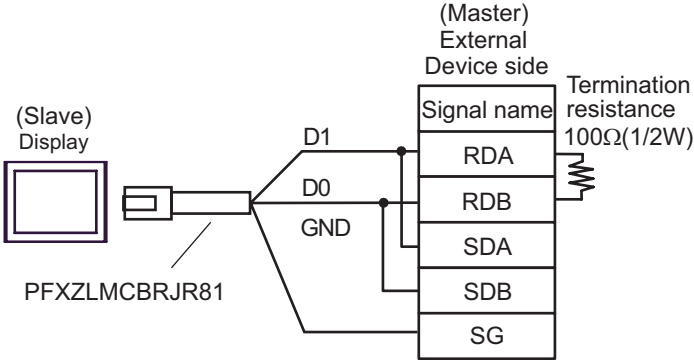

- n:1 Connection

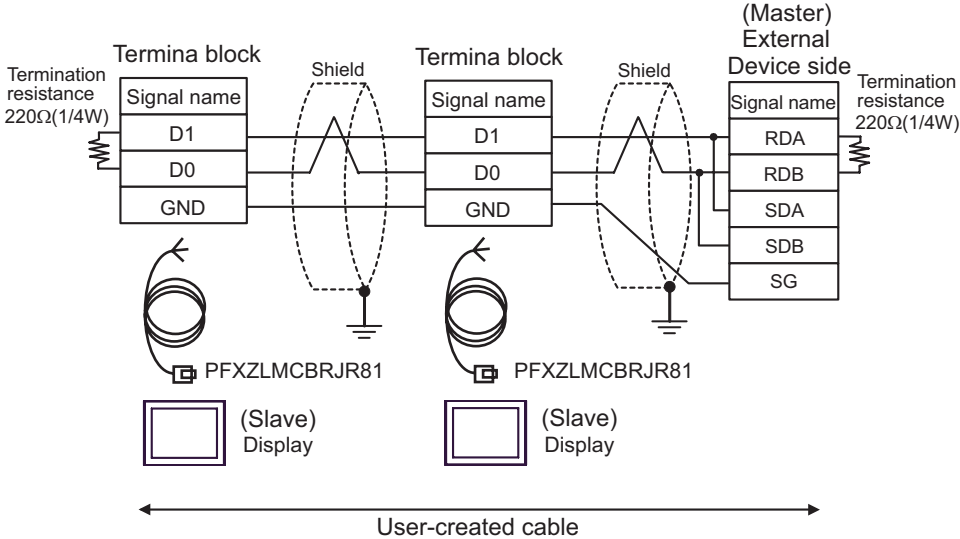

NOTE • Cable length: 1,000m or less (Depends on master's capacity)

1K)

- 1:1 Connection

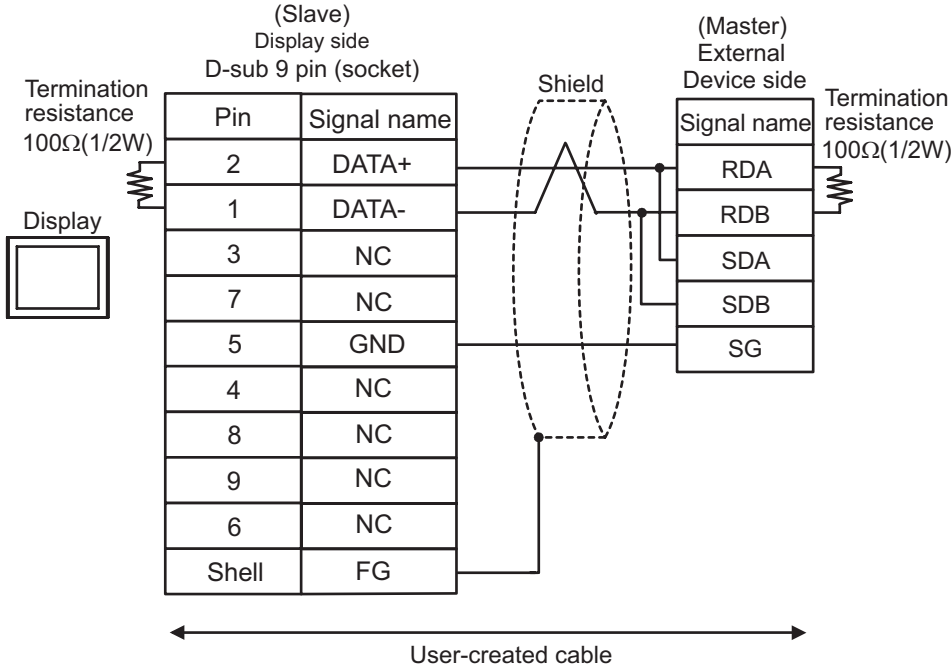

- n:1 Connection

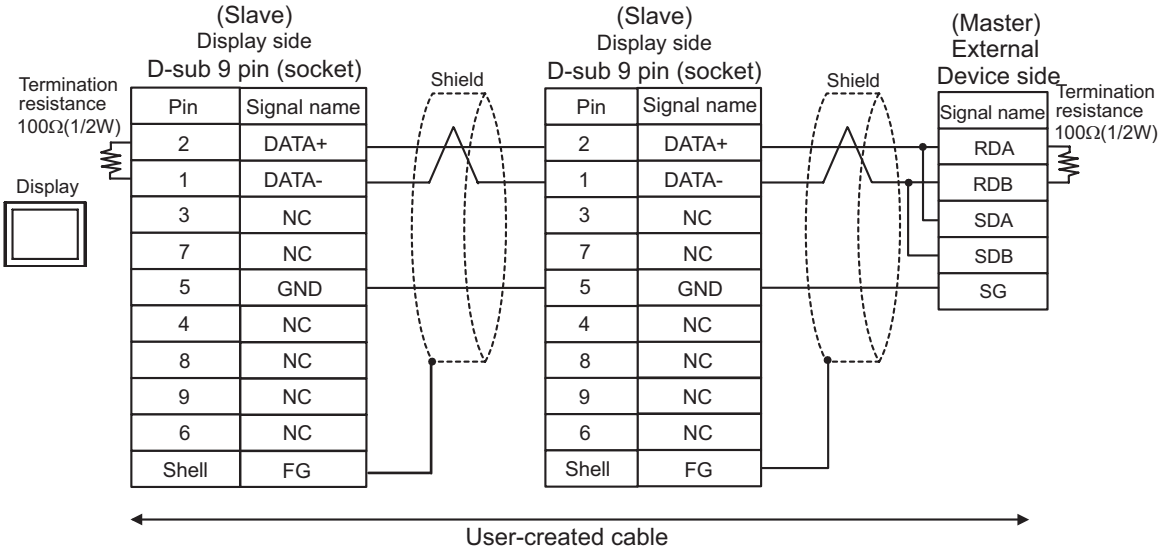

NOTE • Cable length: 1,000m or less (Depends on master's capacity)

5.2 Cable Diagram 2

Display (Connection Port)	Cable		Remarks
GP3000 (COM1) GP4000* ¹ (COM1) SP5000* ² (COM1/2) SP-5B00 (COM1) ST3000 (COM1) ST6000 (COM1) LT3000 (COM1) IPC* ³ PC/AT	2A	User-created cable (flow control:none)	Cable length: 15m or less
	2B	User-created cable (flow control:DTR/CTS)	
GP-4105 (COM1) GP-4115T (COM1) GP-4115T3 (COM1)	2C	User-created cable (flow control:none)	Cable length: 15m or less
	2D	User-created cable (flow control:DTR/CTS)	
LT-4*01TM (COM1) LT-Rear Module (COM1)	2E	RJ45 RS-232C Cable (5m) by Pro-face PFXZLMCBJR21	Cable length: 5m or less

*1 All GP4000 models except GP-4100 series and GP-4203T

*2 Except SP-5B00

*3 Only the COM port which can communicate by RS-232C can be used.
"■ IPC COM Port" (page 7)

2A)

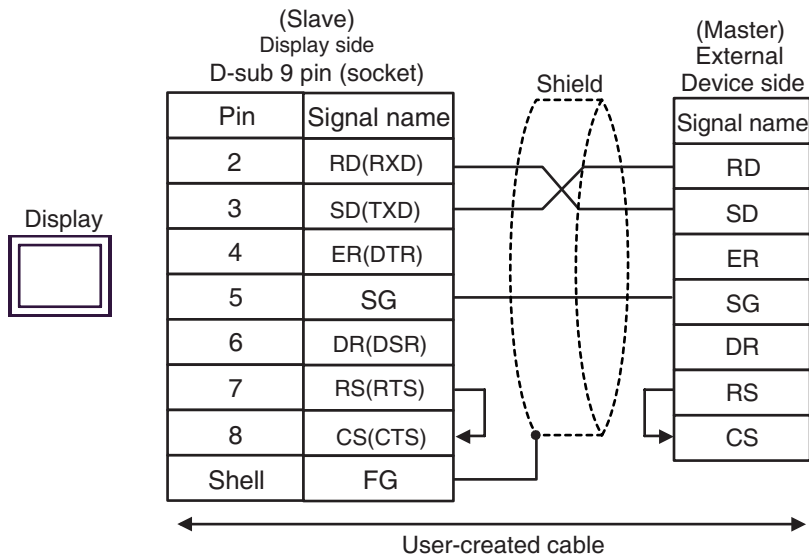

NOTE

- Cable length: 15m or less

2B)

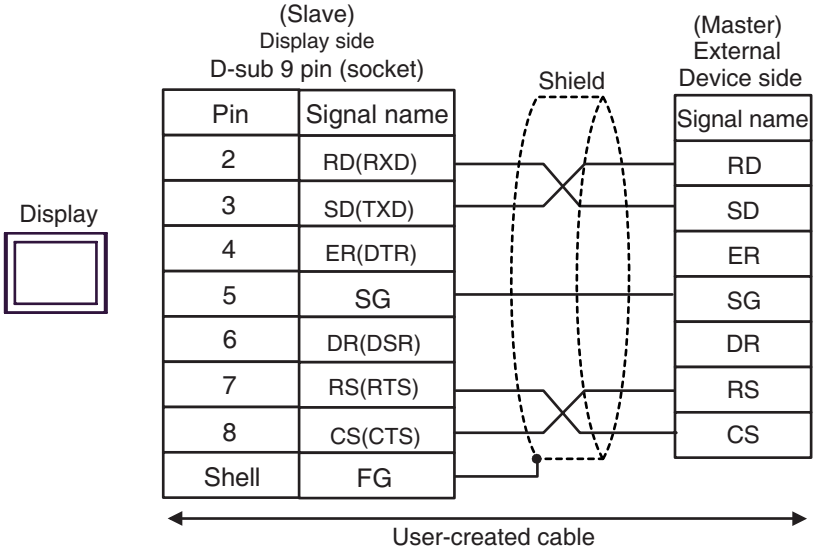

NOTE • Cable length: 15m or less

2C)

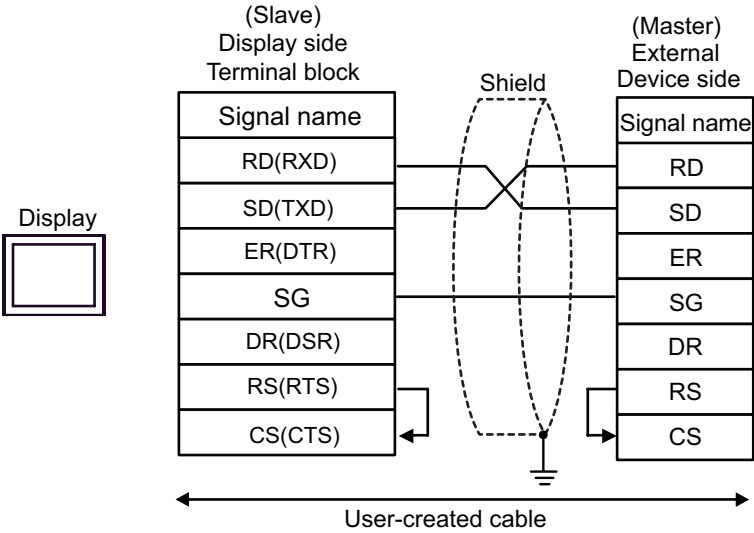

NOTE • Cable length: 15m or less

2D)

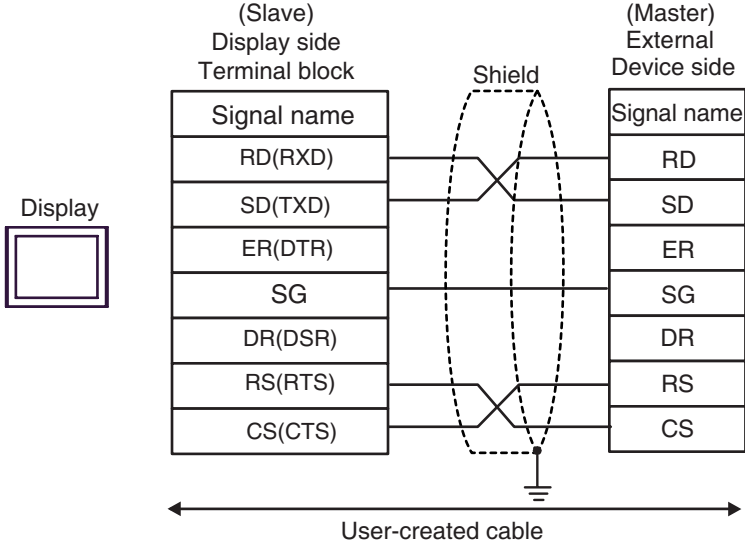

NOTE • Cable length: 15m or less

2E)

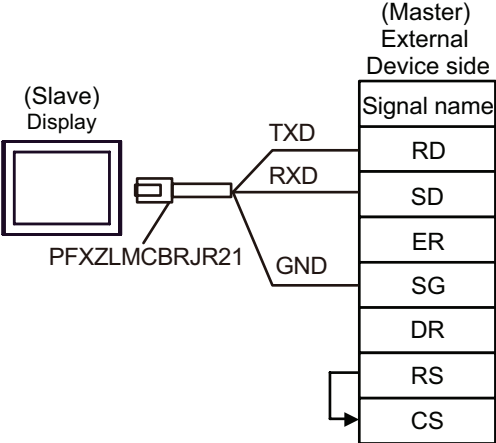

5.3 Cable Diagram 3

Display (Connection Port)	Cable		Remarks
GP3000* ¹ (COM1) AGP-3302B (COM2) GP-4*01TM (COM1) GP-Rear Module (COM1) ST3000* ² (COM2) LT3000 (COM1) IPC* ³	3A	COM Port Conversion Adapter by Pro-face CA3-ADPCOM-01 + Terminal Block Conversion Adapter by Pro-face CA3-ADPTRM-01 + User-created cable	Cable length: 1,000m or less (Depends on master's capacity)
	3B	User-created cable	
GP3000* ⁴ (COM2)	3C	Online Adapter by Pro-face CA4-ADPONL-01 + Terminal Block Conversion Adapter by Pro-face CA3-ADPTRM-01 + User-created cable	Cable length: 1,000m or less (Depends on master's capacity)
	3D	Online Adapter by Pro-face CA4-ADPONL-01 + User-created cable	
GP-4106 (COM1) GP-4116T (COM1)	3E	User-created cable	Cable length: 1,000m or less (Depends on master's capacity)
GP4000* ⁵ (COM2) GP-4201T (COM1) SP5000* ⁶ (COM1/2) SP-5B00 (COM2) ST6000* ⁷ (COM2) ST-6200 (COM1)	3F	RS-422 Terminal Block Conversion Adapter by Pro-face PFXZCBADTM1 * ⁸ + User-created cable	Cable length: 1,000m or less (Depends on master's capacity)
	3B	User-created cable	
PE-4000B* ⁹ PS5000* ⁹ PS6000* ⁹	3G	User-created cable	Cable length: 1,000m or less (Depends on master's capacity)

*1 All GP3000 models except AGP-3302B

*2 Except AST-3211A and AST-3302B

*3 Only the COM port which can communicate by RS-422/485 (4 wire) can be used. (Except PE-4000B, PS5000, and PS6000)

"■ IPC COM Port" (page 7)

*4 All GP3000 models except GP-3200 series and AGP-3302B

*5 All GP4000 models except GP-4100 series, GP-4*01TM, GP-Rear Module, GP-4201T and GP-4*03T

*6 Except SP-5B00

- *7 Except ST-6200
- *8 When using a Terminal Block Conversion Adapter (CA3-ADPTRM-01) instead of the RS-422 Terminal Block Conversion Adapter, refer to Cable Diagram 3A.
- *9 Only the COM port which can communicate by RS-422/485 (4 wire) can be used.
 "■ IPC COM Port" (page 7)

3A)

- 1:1 Connection

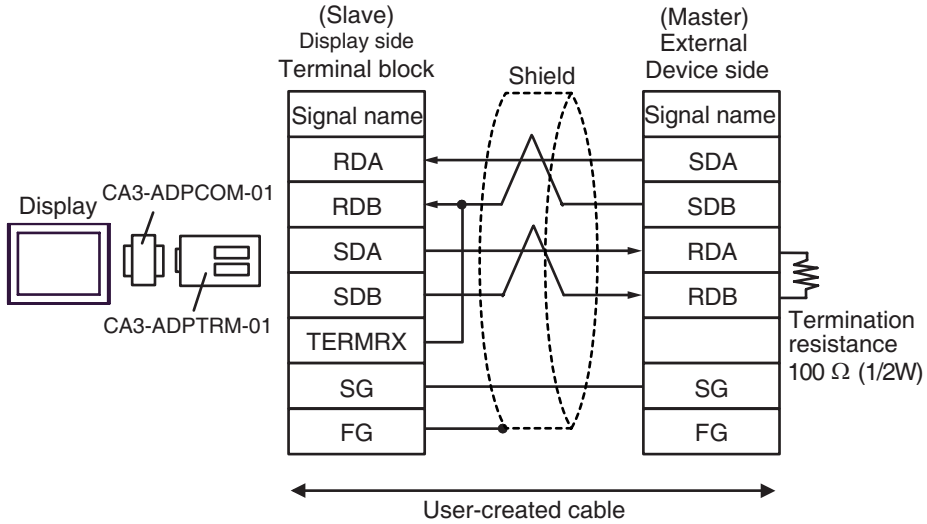

- n:1 Connection

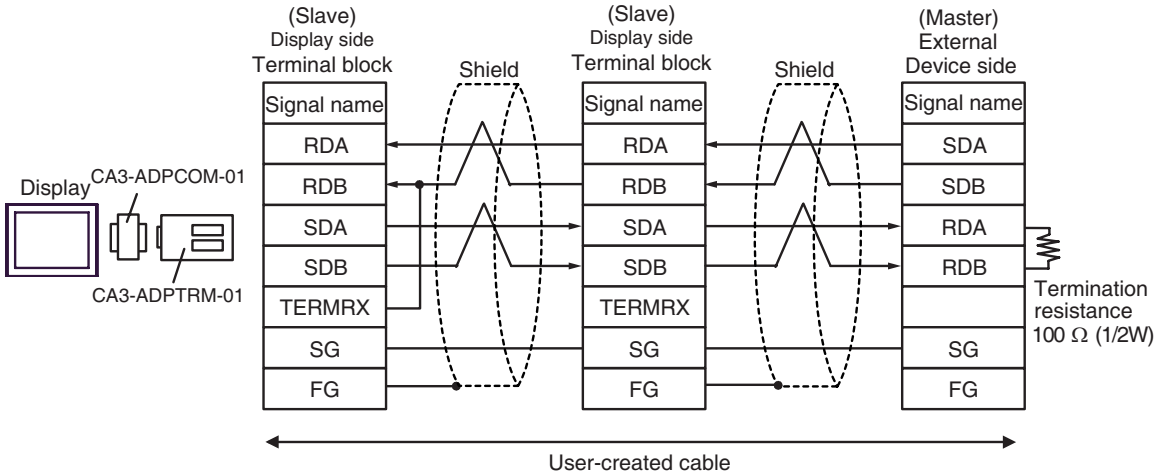

NOTE

- Cable length: 1,000m or less(Depends on master's capacity)

3B)

- 1:1 Connection

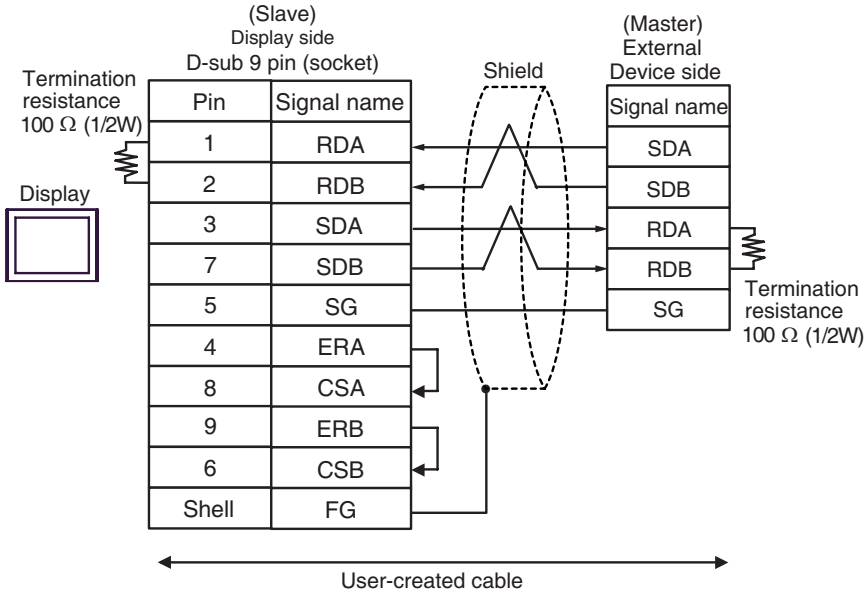

- n:1 Connection

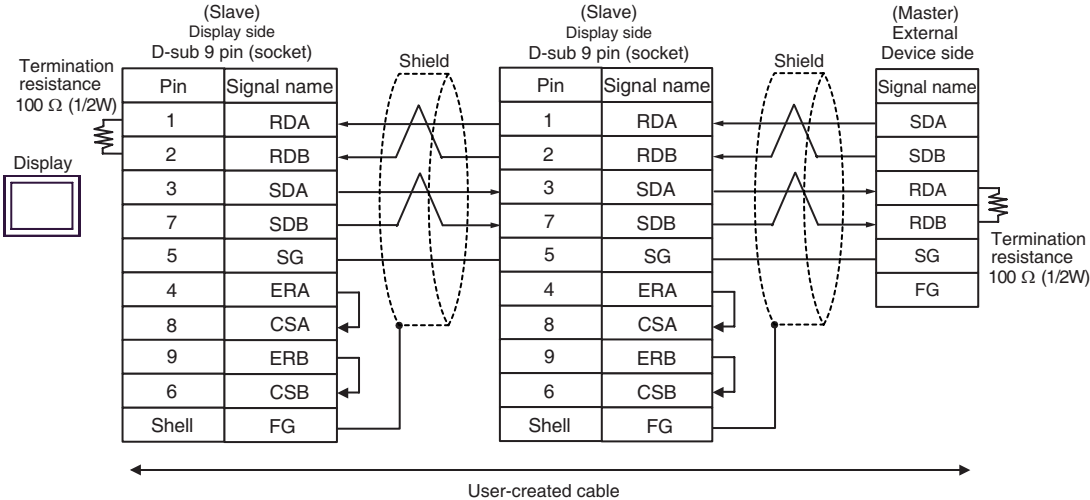

NOTE • Cable length: 1,000m or less(Depends on master's capacity)

3C)

- 1:1 Connection

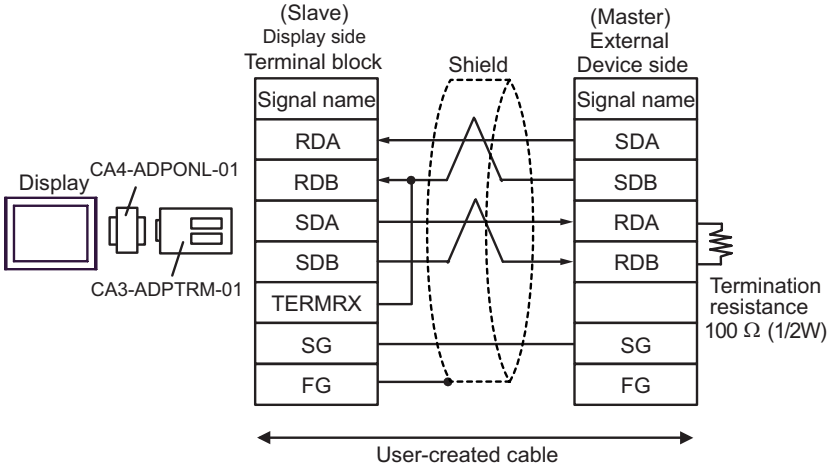

- n:1 Connection

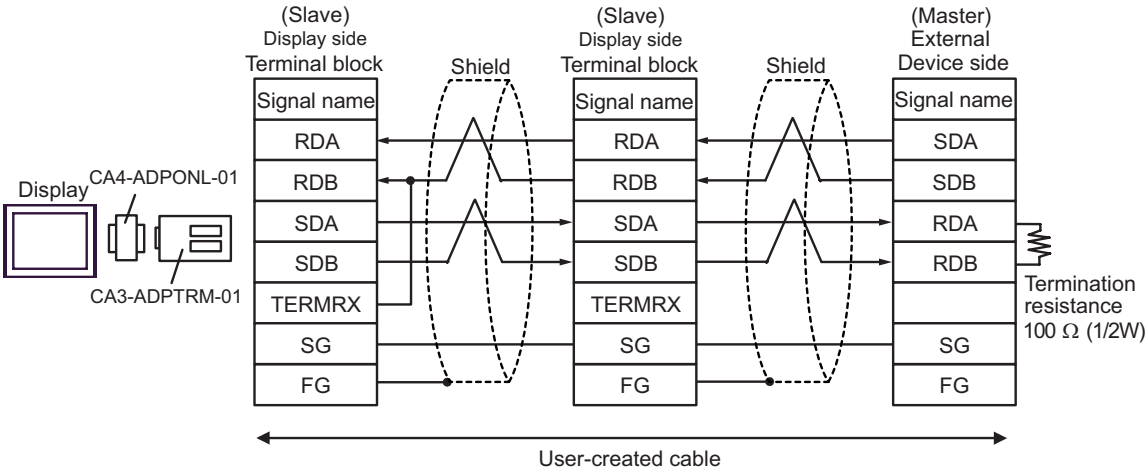

NOTE

- Cable length: 1,000m or less(Depends on master's capacity)

3D)

- 1:1 Connection

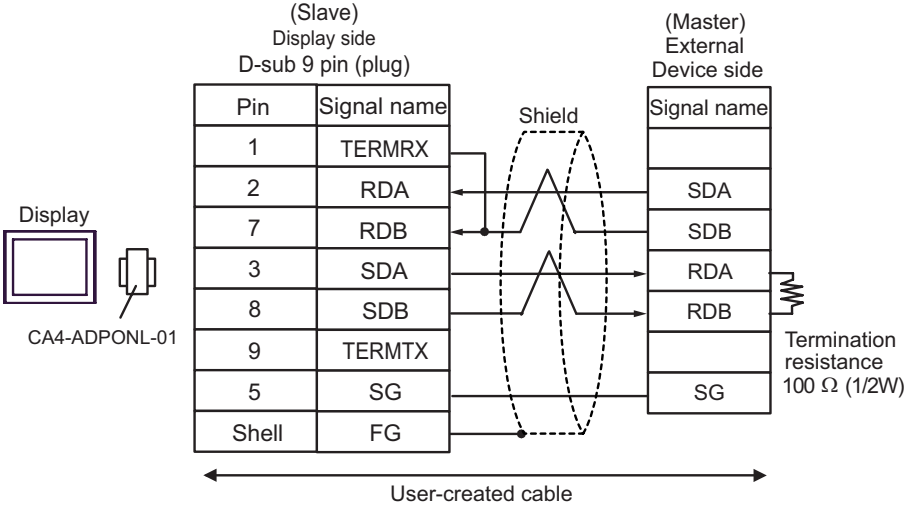

- n:1 Connection

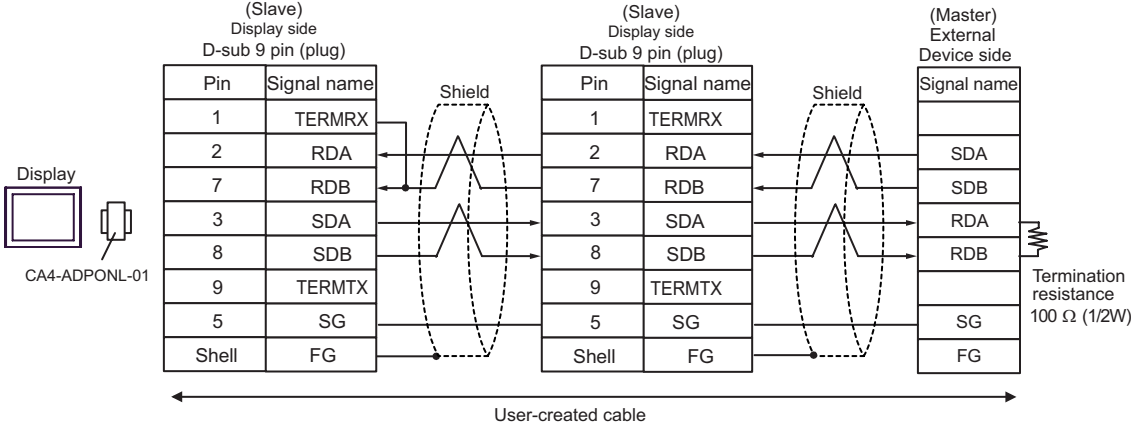

NOTE

- Cable length: 1,000m or less(Depends on master's capacity)

3E)

- 1:1 Connection

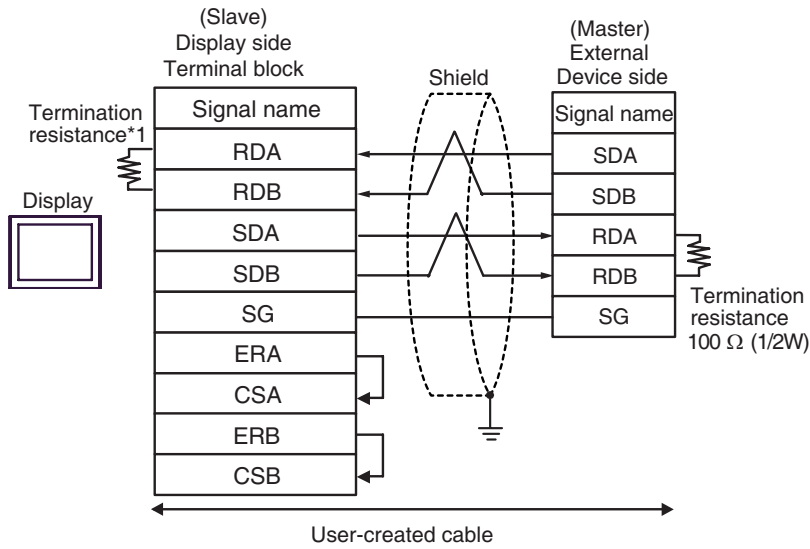

- n:1 Connection

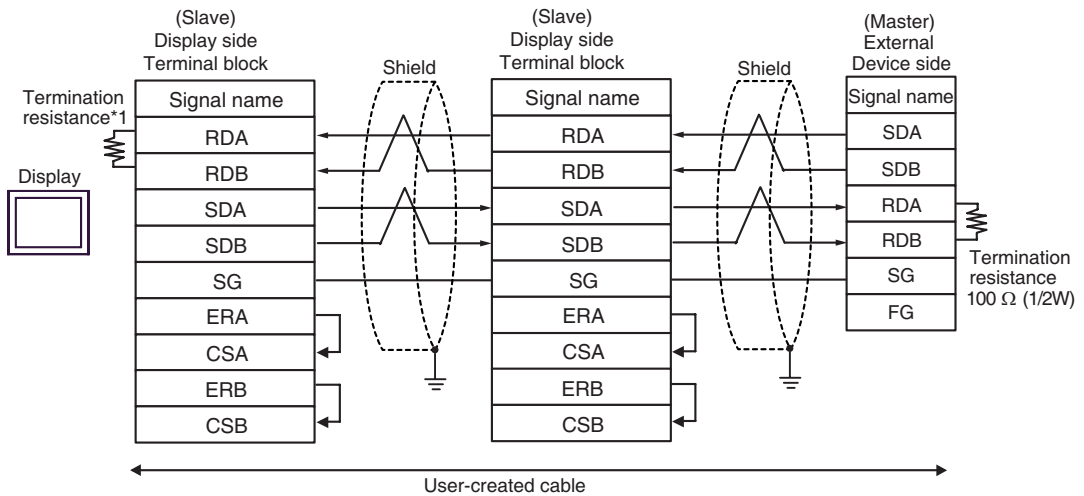

*1 The resistance in the Display is used as the termination resistance. Set the value of the DIP Switch on the rear of the Display as shown in the table below.

DIP Switch No.	Set Value
1	OFF
2	OFF
3	ON
4	ON

For the Displays other than that used as the terminal, set the DIP Switch 1-4 on the rear of the Display to OFF in the n:1 connection.

NOTE

- Cable length: 1,000m or less(Depends on master's capacity)

3F)

- 1:1 Connection

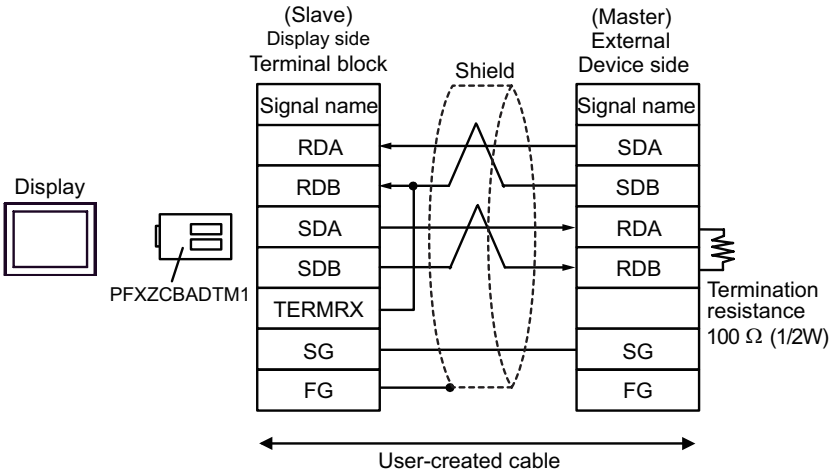

- n:1 Connection

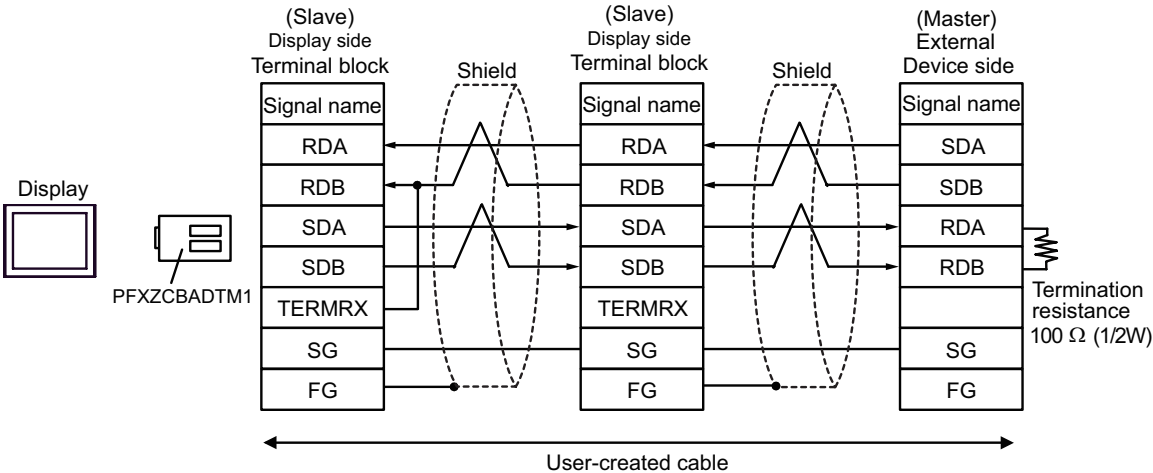

NOTE • Cable length: 1,000m or less(Depends on master's capacity)

3G)

- 1:1 Connection

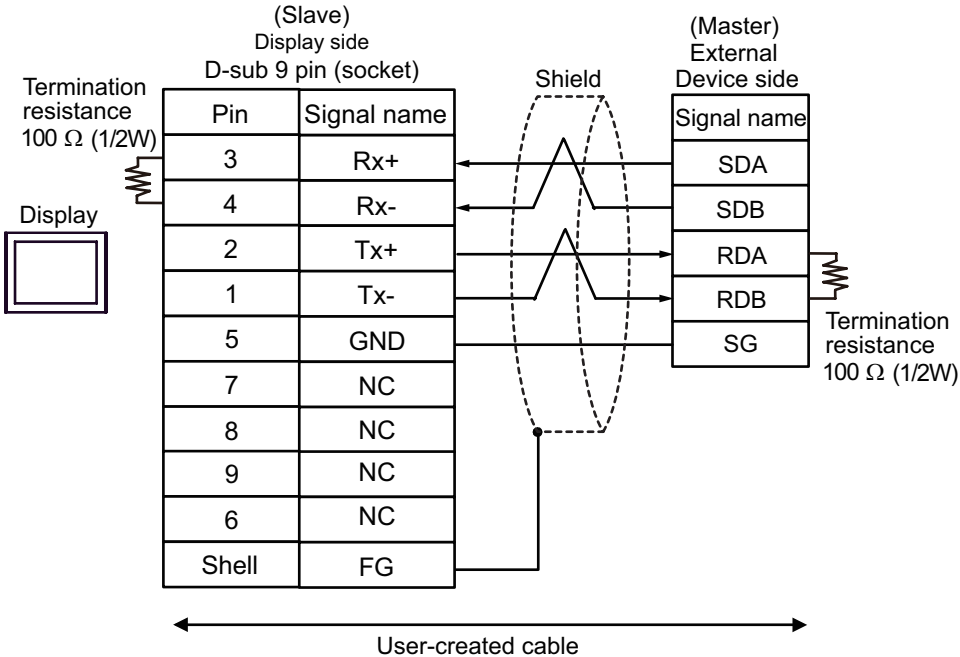

- n:1 Connection

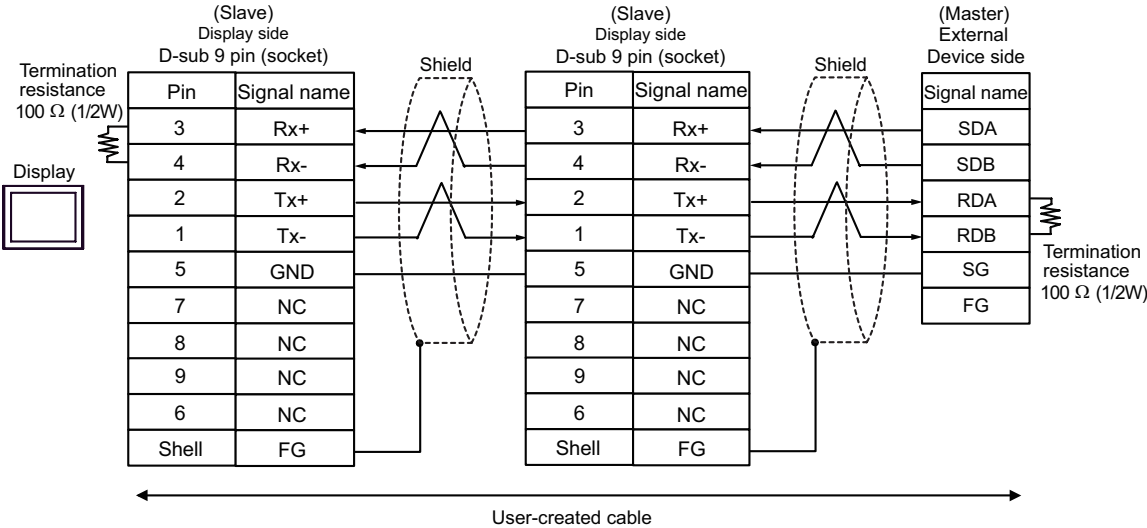

NOTE

- Cable length: 1,000m or less(Depends on master's capacity)

6 Supported Device

Range of supported device address is shown in the table below. Please note that the actually supported range of the devices varies depending on the External Device to be used. Please check the actual range in the manual of your External Device.

400001-410000 This address can be specified as system data area.

Device	Bit Address	Word Address	32 bits	Remarks
Coil	000001-008192	000001-008177	<div style="display: flex; flex-direction: column; align-items: center;"> <div style="border: 1px solid black; padding: 2px; margin-bottom: 5px;">L/H</div> <div style="margin-bottom: 5px;">or</div> <div style="border: 1px solid black; padding: 2px; margin-bottom: 5px;">H/L</div> <div>*1</div> </div>	→1B+ 1
Discrete Input	100001-108192	100001-108177		→1B+ 1 *2
Input Register	300001,00-310000.15	300001-310000		B i t 15 *2
Holding Register	400001,00-410000,15	400001-410000		B i t 15

*1 You can set the data storing order in word unit of 32-bit data in the Device Setting dialog box.

*2 Write operations using this driver is possible; however, write operations from the server are not possible.

IEC61131 Syntax Address Description

The following is a corresponding table for IEC61131 syntax and MODBUS syntax address descriptions.

Device	MODBUS Syntax			IEC61131 Syntax				
	Format	Range	First element	Format	0-based		1-based	
					Range	First element	Range	First element
Coil	000001+i	i = 0 to 8191	000001	%Mi	i = 0 to 8191	%M00000	i = 1 to 8192	%M00001
Discrete Input	100001+i	i = 0 to 8191	100001	-	-	-	-	-
Input Register (Word)	300001+i	i = 0 to 9999	300001	-	-	-	-	-
Input Register (Word bit)	300001+i, j	i = 0 to 9999 j = 0 to 15	300001,0 0	-	-	-	-	-
Holding Register (Word)	400001+i	i = 0 to 9999	400001	%MWi	i = 0 to 9999	%MW00000	i = 1 to 10000	%MW00001
Holding Register (Word bit)	400001+i, j	i = 0 to 9999 j = 0 to 15	400001,0 0	%MWi :Xj	i = 0 to 9999 j = 0 to 15	%MW00000 :X00	i = 1 to 10000 j = 0 to 15	%MW00001 :X00

NOTE

- The addresses 100000 and 300000 cannot be accessed using IEC61131 syntax.
- If you apply IEC61131 syntax to a project which has a discrete input or input register already set, the addresses become "-Undefined-".

NOTE

- Please refer to the GP-Pro EX Reference Manual for system data area.

Cf. GP-Pro EX Reference Manual "LS Area (Direct Access Method Area)"

- Please refer to the precautions on manual notation for icons in the table.

 "Manual Symbols and Terminology"

7 Device Code and Address Code

Use device code and address code when you select "Device Type & Address" for the address type in data displays.

7.1 Modicon Syntax

Device	Device Name	Device Code (HEX)	Address Code
Coil	0	0080	(Word Address - 1) /16
Discrete Input	1	0081	(Word Address - 1) /16
Input Register	3	0001	Word Address - 1
Holding Register	4	0000	Word Address - 1

7.2 IEC61131 Syntax

- Address Mode: 0-based

Device	Device Name	Device Code (HEX)	Address Code
Coil	%M	0080	Word Address /16
Holding Register	%MW	0000	Word Address

- Address Mode: 1-based

Device	Device Name	Device Code (HEX)	Address Code
Coil	%M	0080	(Word Address - 1) /16
Holding Register	%MW	0000	Word Address - 1

8 Error Messages

Error messages are displayed on the screen of the Display as follows: "No. : Device Name: Error Message(Error Occurrence Area)". Each description is shown below.

Item	Description
No.	Error No.
Device Name	Name of the External Device where error occurs. Device name is a title of the External Device set with GP-Pro EX.((Initial value[PLC1])
Error Message	Displays messages related to the error which occurs.
Error Occurrence Area	<p>Displays IP address or device address of the External Device where error occurs, or error codes received from the External Device.</p> <p>NOTE</p> <ul style="list-style-type: none"> • IP address is displayed such as "IP address(Decimal): MAC address(Hex)". • Device address is displayed such as "Address: Device address". • Received error codes are displayed such as "Decimal[Hex]".

Display Examples of Error Messages

"RHAA035: PLC1: Error has been responded for device write command (Error Code: 2[02H])"

-
- NOTE**
- Please refer to the manual of the External Device for more detail of received error codes.
 - Refer to "Display-related errors" in "Maintenance/Troubleshooting Guide" for details on the error messages common to the driver.
-

■ Error Codes Specific to the External Device

Error codes specific to the External Device are shown below.

Error Code	Description
RHxx128	Checksum does not match the packet actually received.
RHxx129	The MODBUS slave driver cannot be shared between COM1 and COM2.
RHxx130	The MODBUS slave driver cannot be used with the driver for COM%d.

9 Command Format

This driver supports the commands below.

Command	Function code		Minimum Points	Maximum Points	Device
Bit Block Read	Read Coil Status	0x01	16 Bits	2000 Bits	Coil
	Read Input Status	0x02			Discrete Input
Word Block Read	Read Holding Register	0x03	1 Word	125 Words	Holding Register
	Read Input Register	0x04			Input Register
Bit Block Write	Force Single Coil	0x05	1 Bit	1 Bit	Coil
	Force Multiple Coils	0x0F	1 Bit	1968 Bits	
Word Block Write	Preset Single Register	0x06	1 Word	1 Word	Holding Register
	Preset Multiple Registers	0x10	1 Word	123 Words	
Diagnostics ^{*1 *2}	Preset Loop Back	0x08	-	-	-

*1 Diagnostics command is supported by the driver of which version is V1.12.02 or later.

*2 Diagnostics command is only supported by serial communication.