



MP Ethernet/ MECHATROLINK Driver

1	System Configuration.....	3
2	External Device Selection	28
3	Communication Settings	29
4	Setup Items	157
5	Supported Devices.....	167
6	Device Code and Address Code.....	192
7	Error Messages.....	196

Introduction

This manual describes how to connect the Display and the External Device (target PLC).
In this manual, the connection procedure will be described in the sections identified below:

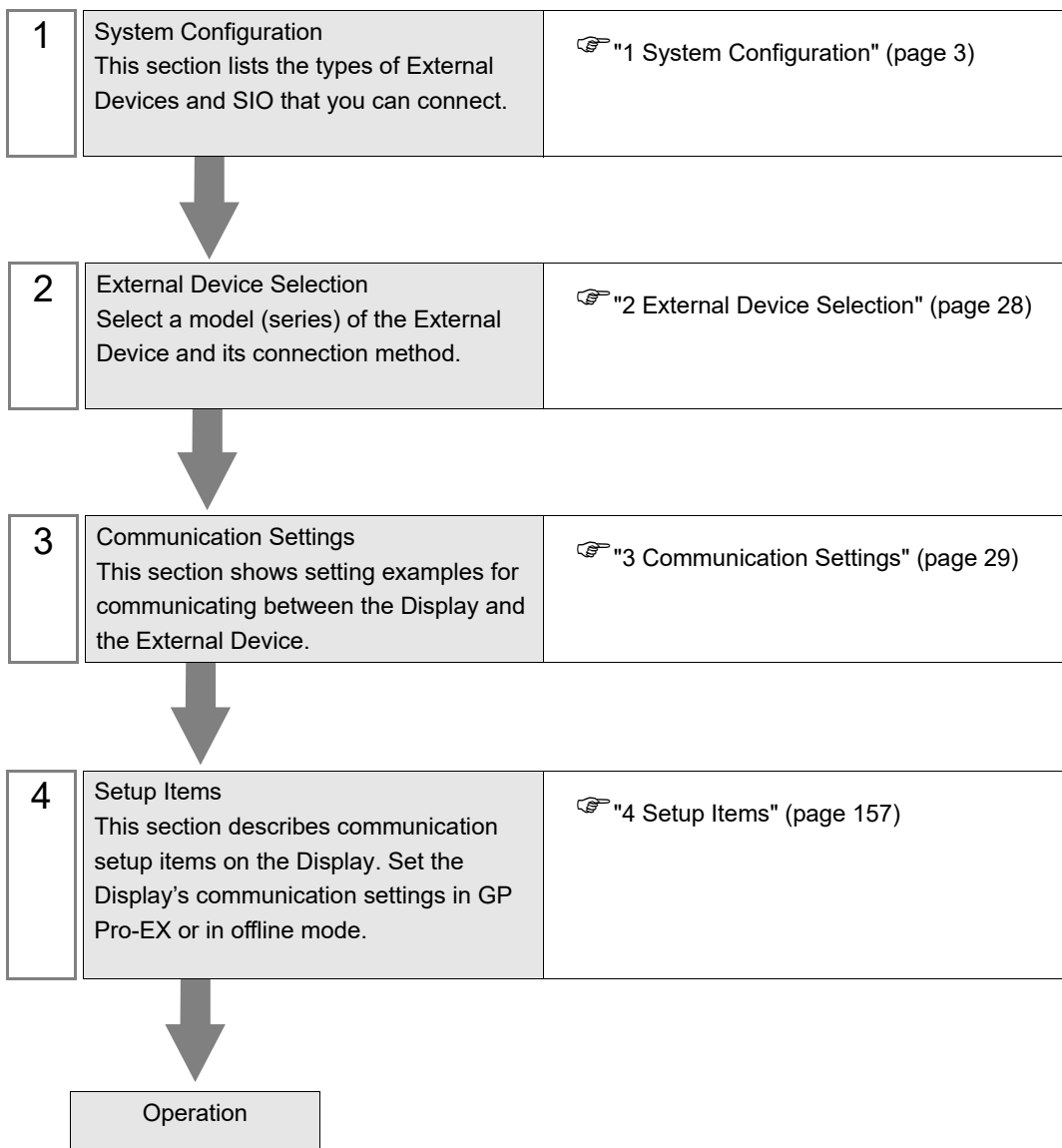

1 System Configuration

The system configuration in the case when the External Device and the Display are connected is shown.

1.1 MP Series

Series	CPU	Link I/F	SIO Type	Setting Example
MP2000	MP2300 MP2200	Ethernet port on 218IF-01	Ethernet (UDP)	"3.1 Setting Example 1" (page 29)
		Ethernet port on 218IF-02	Ethernet (UDP)	"3.4 Setting Example 4" (page 38)
	MP2310 MP2300S	Ethernet Connector on CPU unit	Ethernet (UDP)	"3.2 Setting Example 2" (page 32)
		Ethernet port on 218IF-01	Ethernet (UDP)	"3.3 Setting Example 3" (page 35)
		Ethernet port on 218IF-02	Ethernet (UDP)	"3.4 Setting Example 4" (page 38)
	MP2400	Ethernet Connector on CPU unit	Ethernet (UDP)	"3.2 Setting Example 2" (page 32)
	MPU-01*1	Ethernet port on Main CPU*2 or Ethernet port on 218IF-01	Ethernet (UDP)	"3.12 Setting Example 12" (page 59)
MP3000	CPU-201 CPU-301 CPU-302	Ethernet Connector on CPU unit	Ethernet (UDP)	"3.9 Setting Example 9" (page 53)
	CPU-201(SUB)*3	Ethernet Connector on Main CPU (CPU201)	Ethernet (UDP)	"3.15 Setting Example 15" (page 67)
		Ethernet Connector on CPU201(SUB)	Ethernet (UDP)	"3.9 Setting Example 9" (page 53)
	Σ -7C*4	Ethernet Port on CPU unit	Ethernet (UDP)	"3.9 Setting Example 9" (page 53)

*1 The firmware version of the MPU-01 to be supported is Ver. 2.86 or later.

*2 Please refer to the MPU-01 Manual for the supported list of Main CPUs.

*3 The firmware version of the CPU-201 to be supported is Ver. 1.06 or later.

*4 The Display communicates with the Σ -7C controller section.

■ Connection Configuration

- MP Series / Σ -7C (Controller Section)

1:1 Connection

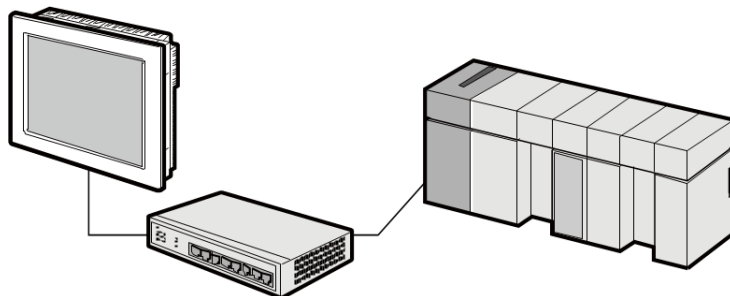

MP2000 (218IF-01): 10BASE-T

MP3000 / Σ -7C (Controller section): 100Base-T

1:n Connection

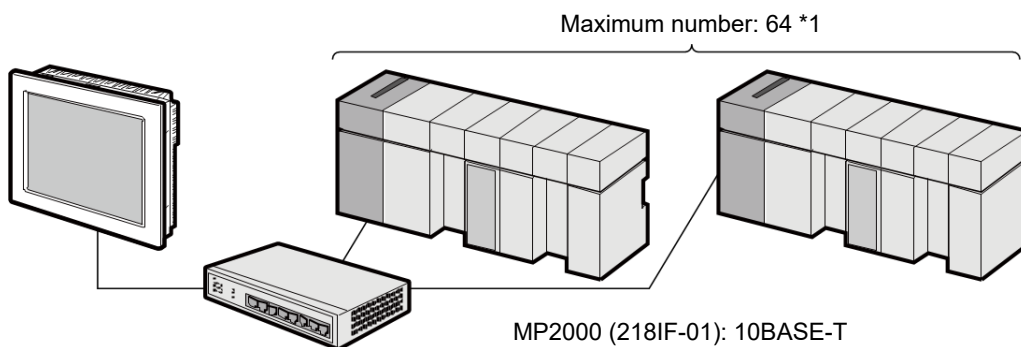

Maximum number: 64 *1

MP2000 (218IF-01): 10BASE-T

MP3000 / Σ -7C (Controller section): 100Base-T

- *1 When 33 or more External Devices are connected, it is necessary to check [Increase allowable number of Devices/PLCs].

☞ "4.1 Setup Items in GP-Pro EX" (page 157)

- MPU-01
1:1 Connection

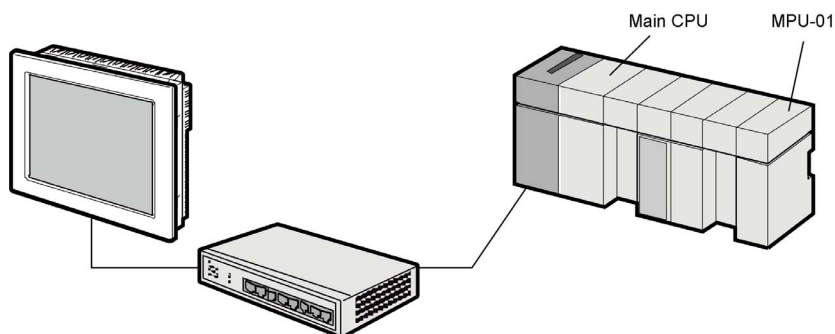

- 1:n Connection

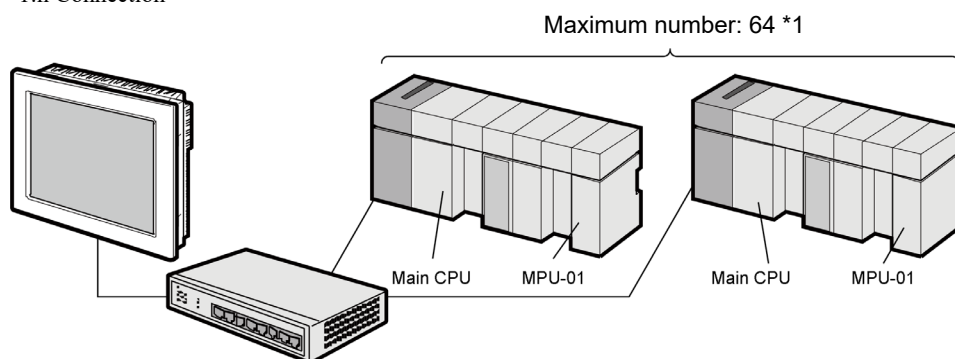

- *1 When 33 or more External Devices are connected, it is necessary to check [Increase allowable number of Devices/PLCs].

☞ "4.1 Setup Items in GP-Pro EX" (page 157)

-
- NOTE** • When connecting to the MPU-01 via the main CPU, do not make communications from two or more devices (e.g. Display and Ladder software) at the same time. If so, the MPU-01 may make no response.
-

- Sub CPU
1:1 Connection

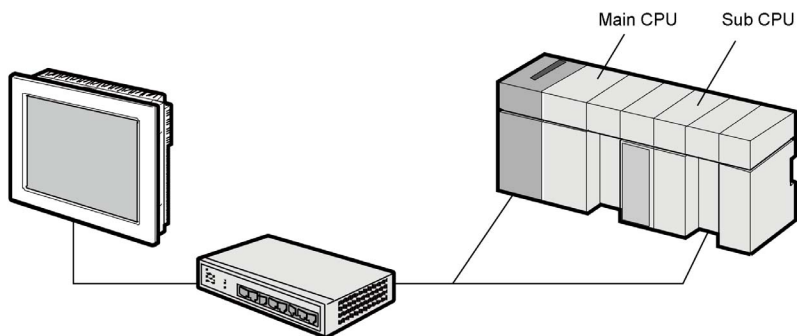

- 1:n Connection

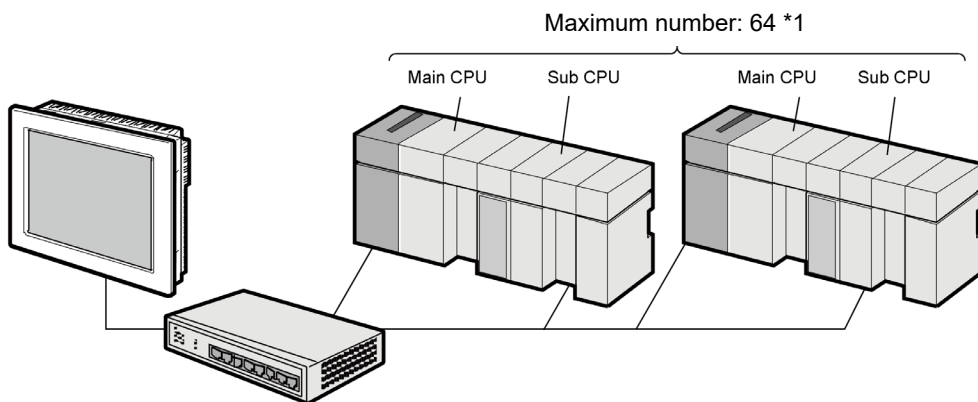

- *1 When 33 or more External Devices are connected, it is necessary to check [Increase allowable number of Devices/PLCs].

☞ "4.1 Setup Items in GP-Pro EX" (page 157)

NOTE

- A Sub CPU can be communicated via a Main CPU or in direct connection.
 - When connecting to the Sub CPU via the main CPU, do not make communications from two or more devices (e.g. Display and Ladder software) at the same time. If so, the Sub CPU may make no response.
-

1.2 Inverter Series

Series	CPU*1	Link I/F	Communication	Setting Example
V1000	CIMR-VA□ A□□□□	V1000 Option MECHATROLINK-II (SI-T3/V)	Ethernet (UDP) and MECHATROLINK-II	"3.10 Setting Example 10" (page 55)
A1000	CIMR-A□□ A□□□□	A1000 MECHATROLINK-II (SI-T3)	Ethernet (UDP) and MECHATROLINK-II	"3.11 Setting Example 11" (page 57)

*1 The □ symbol in the inverter model name represents the maximum applicable motor capacity and other specifications.

■ Connection Configuration

- 1:1 Connection

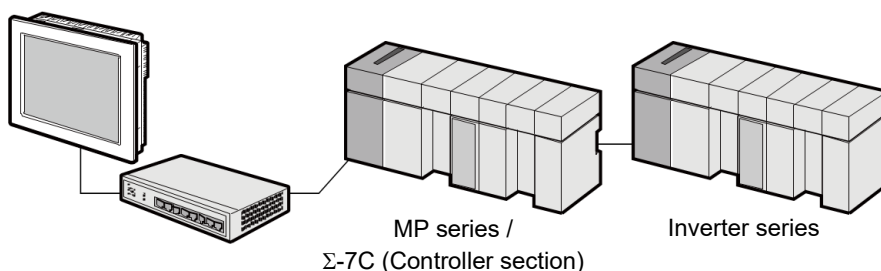

Between Display and MP series / Σ-7C (Controller section): Ethernet connection

Between MP series / Σ-7C (Controller section) and Inverter series: MECHATROLINK connection

- 1:n Connection

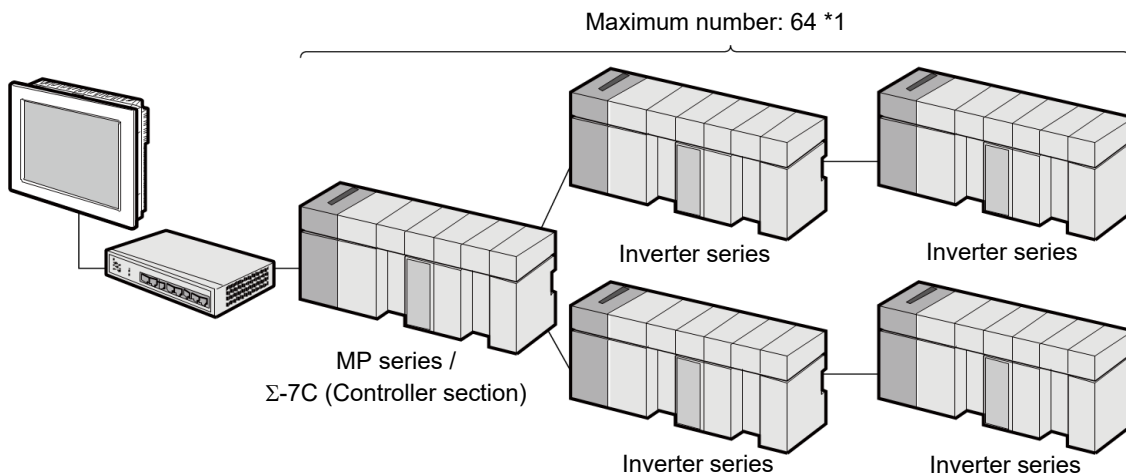

Between Display and MP series / Σ-7C (Controller section): Ethernet connection

Between MP series / Σ-7C (Controller section) and Inverter series: MECHATROLINK connection

Between Inverter series and Inverter series: MECHATROLINK connection

*1 When 33 or more External Devices are connected, it is necessary to check [Increase allowable number of Devices/PLCs].

☞ "4.1 Setup Items in GP-Pro EX" (page 157)

1.3 Servo

Series	CPU	Link I/F	SIO Type	Setting Example
Σ -V Series Rotary Motors (M-II)	SGDV- □□□□11 □□□□□□	MECHATROLINK Communications Connectors (CN6A/CN6B)	Ethernet (UDP) and MECHATROLINK-II	"3.5 Setting Example 5" (page 41)
Σ -V Series Linear Motors (M-II)	SGDV- □□□□15 □□□□□□	MECHATROLINK Communications Connectors (CN6A/CN6B)	Ethernet (UDP) and MECHATROLINK-II	"3.6 Setting Example 6" (page 44)
Σ -V Series Rotary Motors (M-III)	SGDV- □□□□21 □□□□□□	MECHATROLINK Communications Connectors (CN6A/CN6B)	Ethernet (UDP) and MECHATROLINK-III	"3.7 Setting Example 7" (page 47)
		MECHATROLINK Communications Connectors on MPU-01	Ethernet (UDP) and MECHATROLINK-III	"3.13 Setting Example 13" (page 61)
		MECHATROLINK Communications Connectors on Sub CPU	Ethernet (UDP) and MECHATROLINK-III	"3.16 Setting Example 16" (page 69)
Σ -V Series Linear Motors (M-III)	SGDV- □□□□25 □□□□□□	MECHATROLINK Communications Connectors (CN6A/CN6B)	Ethernet (UDP) and MECHATROLINK-III	"3.8 Setting Example 8" (page 50)
		MECHATROLINK Communications Connectors on MPU-01	Ethernet (UDP) and MECHATROLINK-III	"3.14 Setting Example 14" (page 64)
		MECHATROLINK Communications Connectors on Sub CPU	Ethernet (UDP) and MECHATROLINK-III	"3.17 Setting Example 17" (page 72)
Σ -7 Series Single-axis SERVOPACKs (M-II)	SGD7S- □□□□10 □□□□□□	MECHATROLINK Communications Connectors (CN6A/CN6B)	Ethernet (UDP) and MECHATROLINK-II	"3.18 Setting Example 18" (page 75)
Σ -7 Series Single-axis SERVOPACKs (M-III)	SGD7S- □□□□20 □□□□□□	MECHATROLINK Communications Connectors (CN6A/CN6B)	Ethernet (UDP) and MECHATROLINK-III	"3.19 Setting Example 19" (page 78)
		MECHATROLINK Communications Connectors on MPU-01	Ethernet (UDP) and MECHATROLINK-III	"3.20 Setting Example 20" (page 81)
		MECHATROLINK Communications Connectors on Sub CPU	Ethernet (UDP) and MECHATROLINK-III	"3.21 Setting Example 21" (page 84)

Series	CPU	Link I/F	SIO Type	Setting Example
Σ-7 Series 2-axis SERVO- PACKs (M-III)	SGD7W- □□□□20 □□□□□□□	MECHATROLINK Communications Connectors (CN6A/CN6B)	Ethernet (UDP) and MECHATROLINK-III	"3.22 Setting Example 22" (page 87)
		MECHATROLINK Communications Connectors on MPU-01	Ethernet (UDP) and MECHATROLINK-III	"3.23 Setting Example 23" (page 90)
		MECHATROLINK Communications Connectors on Sub CPU	Ethernet (UDP) and MECHATROLINK-III	"3.24 Setting Example 24" (page 93)
Σ-7 Series 2-axis SERVO- PACKs with built- in controller (M-III)	SGD7C- □□□AMAA □□□*1	Ethernet Connector (CN12)	Ethernet (UDP) and MECHATROLINK-III	"3.40 Setting Example 40" (page 137)
Σ-X Series Single-axis SERVO PACKs (M-III)	SGDXS- □□□A	MECHATROLINK Communications Connectors (CN6A/CN6B)	Ethernet (UDP) and MECHATROLINK-III	"3.41 Setting Example 41" (page 139)
		MECHATROLINK Communications Connectors on MPU-01	Ethernet (UDP) and MECHATROLINK-III	"3.42 Setting Example 42" (page 142)
		MECHATROLINK Communications Connectors on Sub CPU	Ethernet (UDP) and MECHATROLINK-III	"3.43 Setting Example 43" (page 145)
Σ-X Series 2-axis SERVO- PACKs (M-III)	SGDXW- □□□A	MECHATROLINK Communications Connectors (CN6A/CN6B)	Ethernet (UDP) and MECHATROLINK-III	"3.44 Setting Example 44" (page 148)
		MECHATROLINK Communications Connectors on MPU-01	Ethernet (UDP) and MECHATROLINK-III	"3.45 Setting Example 45" (page 151)
		MECHATROLINK Communications Connectors on Sub CPU	Ethernet (UDP) and MECHATROLINK-III	"3.46 Setting Example 46" (page 154)

*1 The Display communicates with the Σ-7C servo section.

■ Connection Configuration

- 1:1 Connection
When the MP series is relayed

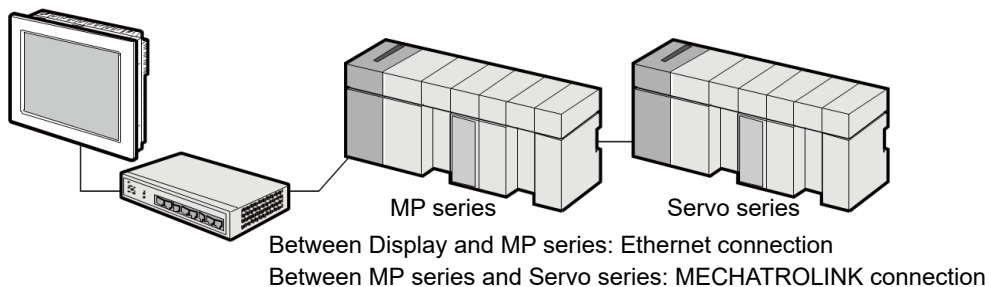

When the Σ -7C is used

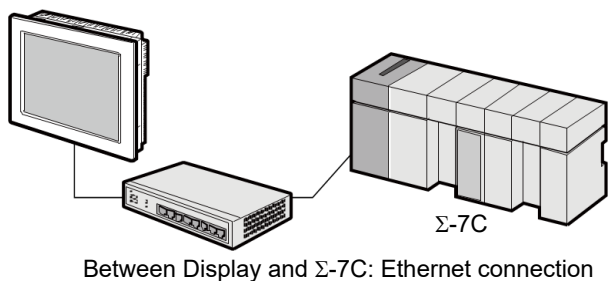

- 1:n Connection

When the MP series / Σ -7C (Controller section) is relayed

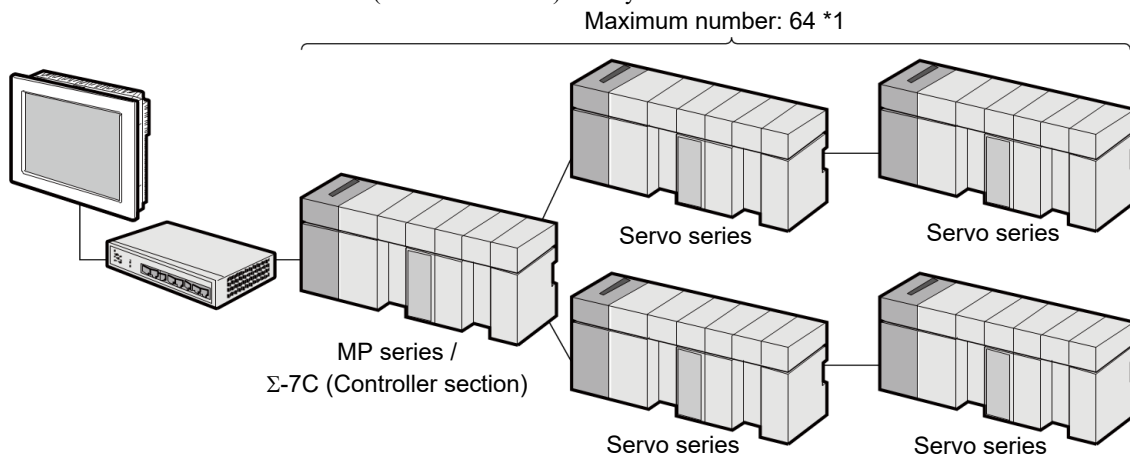

Between Display and MP series / Σ -7C (Controller section): Ethernet connection

Between MP series / Σ -7C (Controller section) and Servo series: MECHATROLINK connection

Between Servo series and Servo series: MECHATROLINK connection

When the Σ -7C is used

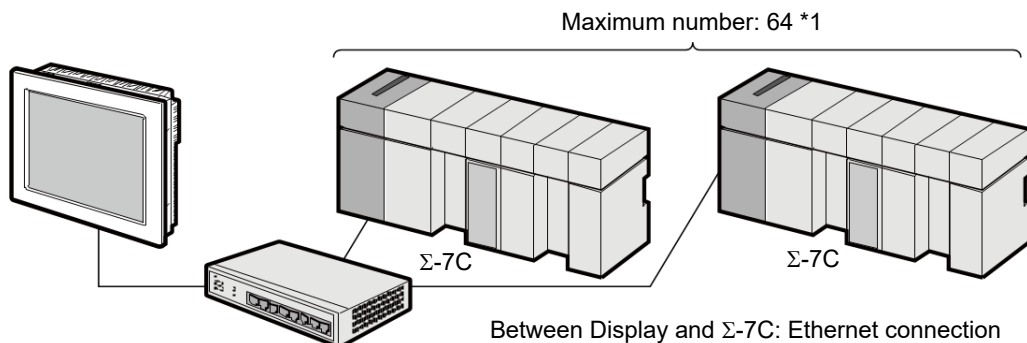

*1 When 33 or more External Devices are connected, it is necessary to check [Increase allowable number of Devices/PLCs].

☞ "4.1 Setup Items in GP-Pro EX" (page 157)

- Connection via MPU-01

1:1 Connection

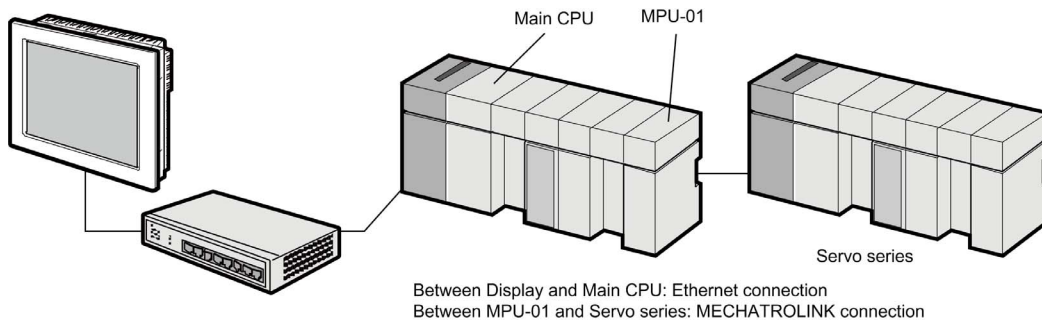

1:n Connection

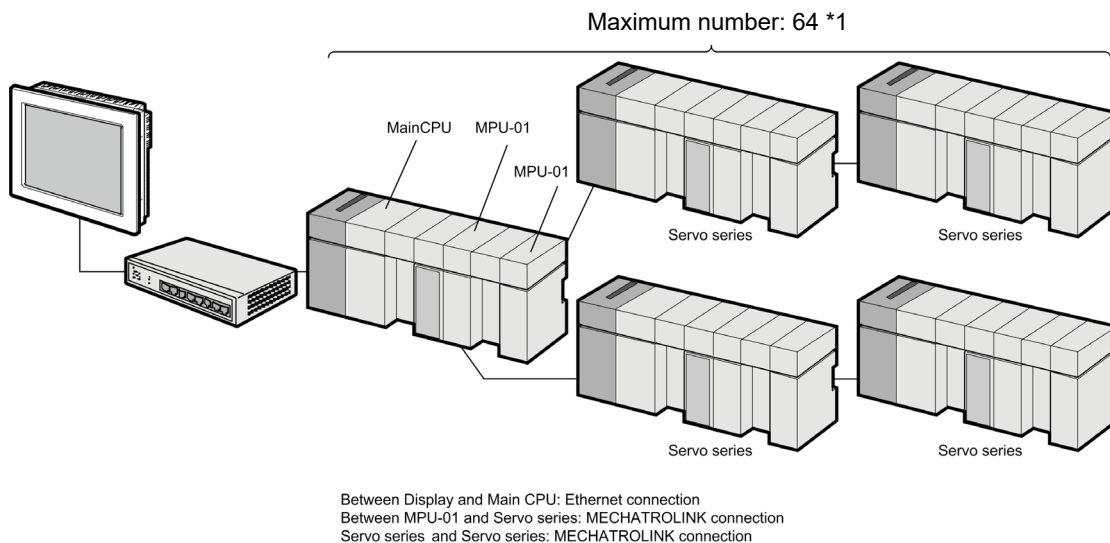

*1 When 33 or more External Devices are connected, it is necessary to check [Increase allowable number of Devices/PLCs].
☞ "4.1 Setup Items in GP-Pro EX" (page 157)

- Connection via Sub CPU

1:1 Connection

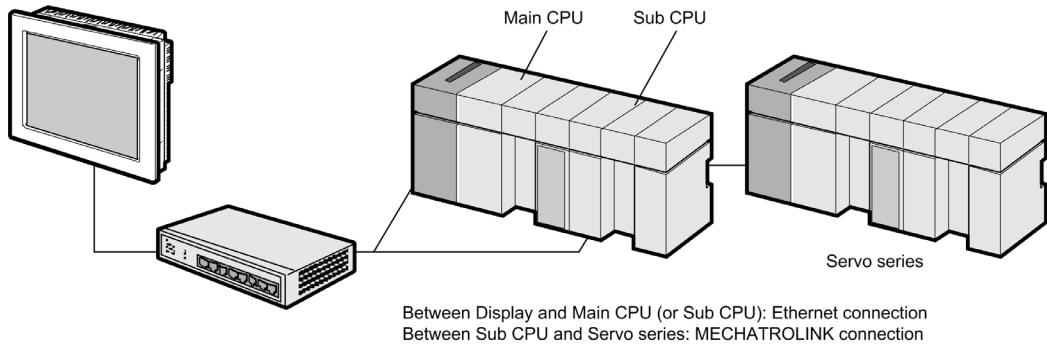

1:n Connection

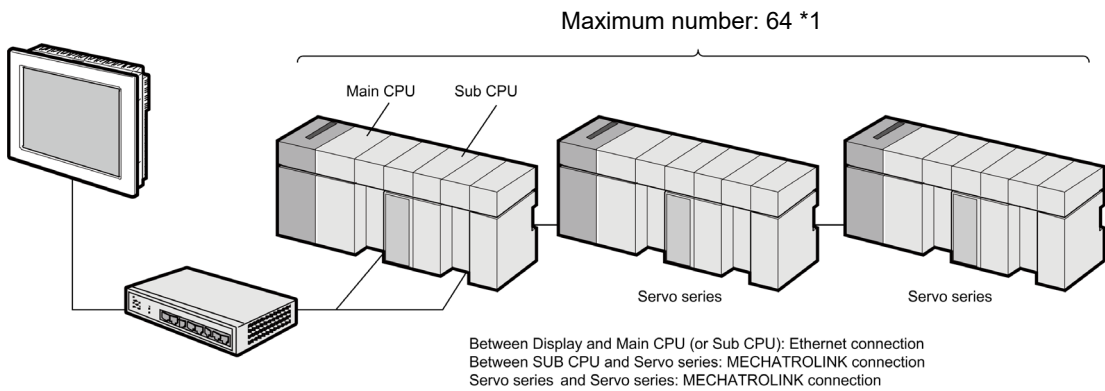

*1 When 33 or more External Devices are connected, it is necessary to check [Increase allowable number of Devices/PLCs].

☞ "4.1 Setup Items in GP-Pro EX" (page 157)

- Connection via Sub CPU and MPU-01

1:1 Connection

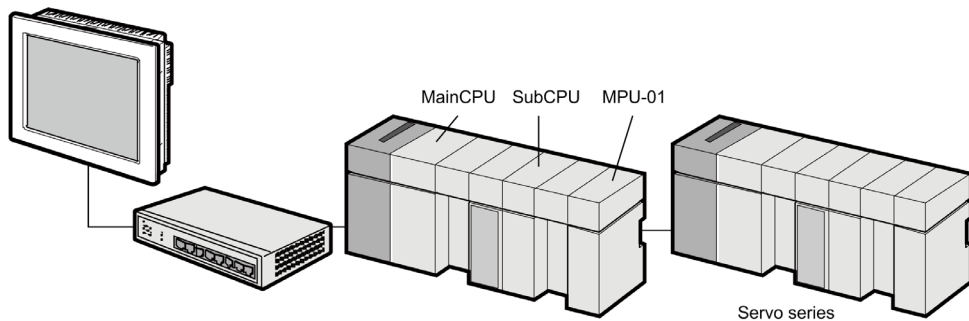

Between Display and Main CPU: Ethernet connection
 Between MPU-01 and Servo series: MECHATROLINK connection

1:n Connection

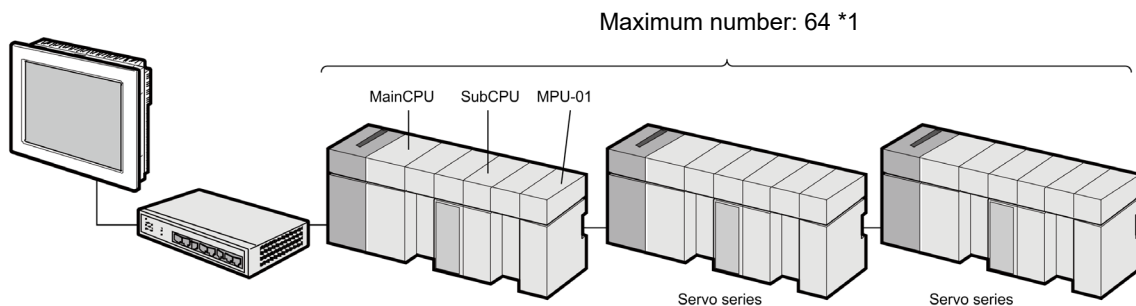

Between Display and Main CPU: Ethernet connection
 Between MPU-01 and Servo series: MECHATROLINK connection
 Servo series and Servo series: MECHATROLINK connection

*1 When 33 or more External Devices are connected, it is necessary to check [Increase allowable number of Devices/PLCs].

☞ "4.1 Setup Items in GP-Pro EX" (page 157)

1.4 I/O(M-System)

Series	CPU	Link I/F	SIO Type	Setting Example
M-System Co., Ltd. Remote I/O	R7G4HML3-6- LC2	MECHATROLINK Communications Connectors (CN6A/CN6B)	Ethernet (UDP) and MECHATROLINK-III	"3.25 Setting Example 25" (page 96)
		MECHATROLINK Communications Connectors on MPU-01	Ethernet (UDP) and MECHATROLINK-III	"3.26 Setting Example 26" (page 98)
		MECHATROLINK Communications Connectors on Sub CPU	Ethernet (UDP) and MECHATROLINK-III	"3.27 Setting Example 27" (page 101)
	R7G4HML3-6- STYVS1	MECHATROLINK Communications Connectors (CN6A/CN6B)	Ethernet (UDP) and MECHATROLINK-III	"3.34 Setting Example 34" (page 121)
		MECHATROLINK Communications Connectors on MPU-01	Ethernet (UDP) and MECHATROLINK-III	"3.35 Setting Example 35" (page 123)
		MECHATROLINK Communications Connectors on Sub CPU	Ethernet (UDP) and MECHATROLINK-III	"3.36 Setting Example 36" (page 126)
	R7G4HML3-6- LC2A	MECHATROLINK Communications Connectors (CN6A/CN6B)	Ethernet (UDP) and MECHATROLINK-III	"3.37 Setting Example 37" (page 129)
		MECHATROLINK Communications Connectors on MPU-01	Ethernet (UDP) and MECHATROLINK-III	"3.38 Setting Example 38" (page 131)
		MECHATROLINK Communications Connectors on Sub CPU	Ethernet (UDP) and MECHATROLINK-III	"3.39 Setting Example 39" (page 134)

■ Connection Configuration

- 1:1 Connection

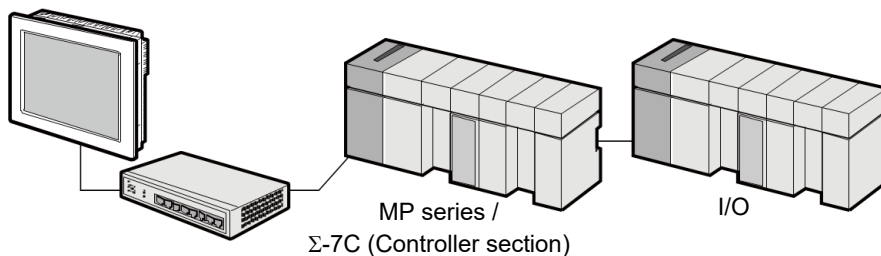

Between Display and MP series / Σ-7C (Controller section): Ethernet connection
 Between MP series / Σ-7C (Controller section) and I/O: MECHATROLINK connection

- 1:n Connection

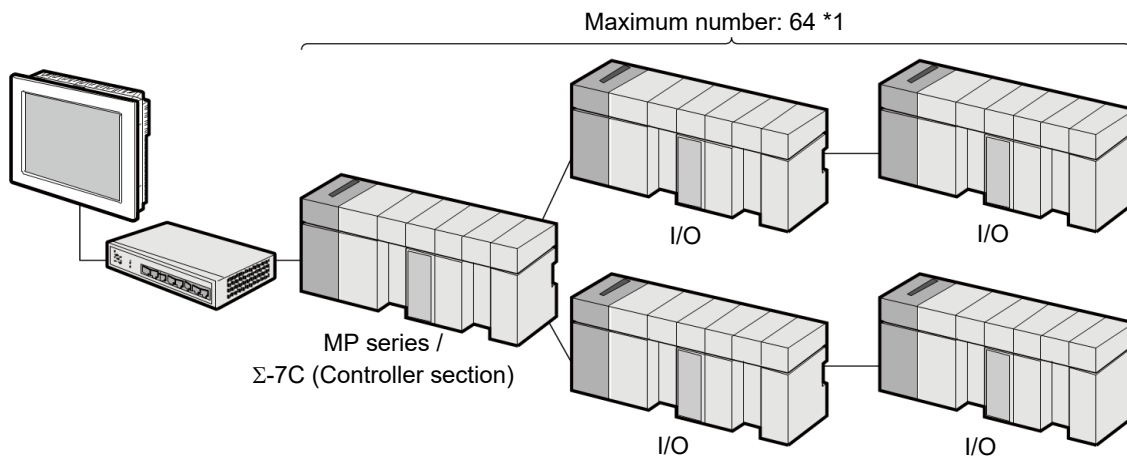

Between Display and MP series / Σ-7C (Controller section): Ethernet connection
 Between MP series / Σ-7C (Controller section) and I/O: MECHATROLINK connection
 Between I/O and I/O: MECHATROLINK connection

- *1 When 33 or more External Devices are connected, it is necessary to check [Increase allowable number of Devices/PLCs].

☞ "4.1 Setup Items in GP-Pro EX" (page 157)

- Connection via MPU-01

1:1 Connection

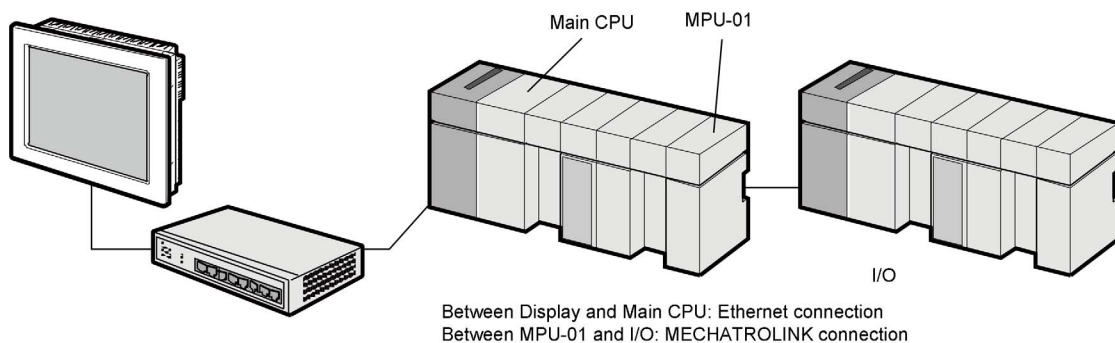

1:n Connection

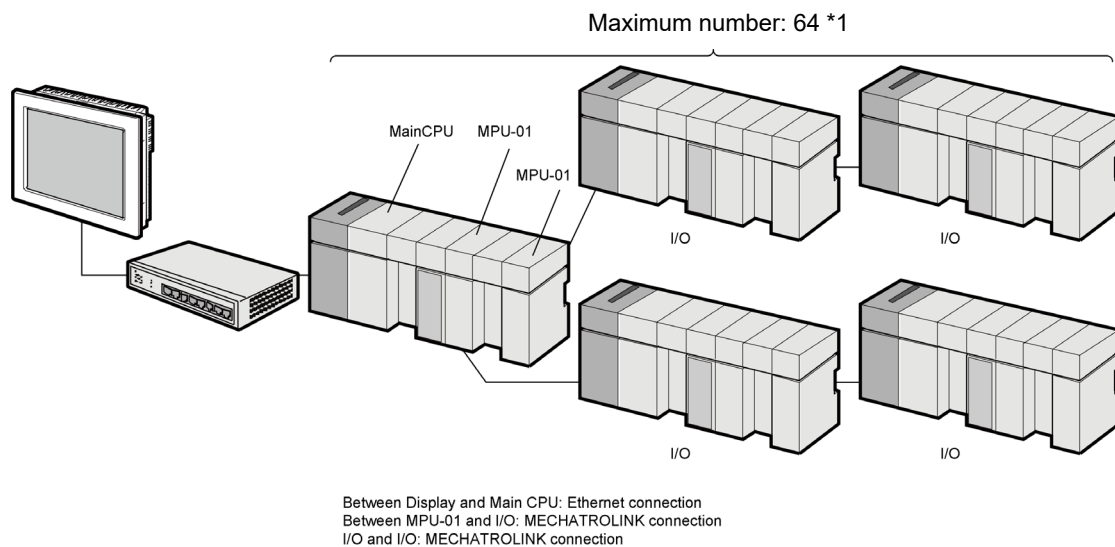

*1 When 33 or more External Devices are connected, it is necessary to check [Increase allowable number of Devices/PLCs].

☞ "4.1 Setup Items in GP-Pro EX" (page 157)

- Connection via Sub CPU

1:1 Connection

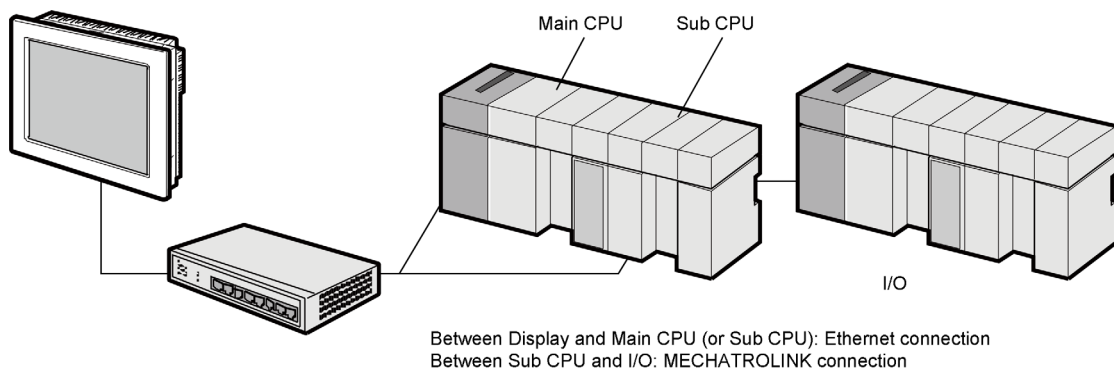

1:n Connection

Maximum number: 64 *1

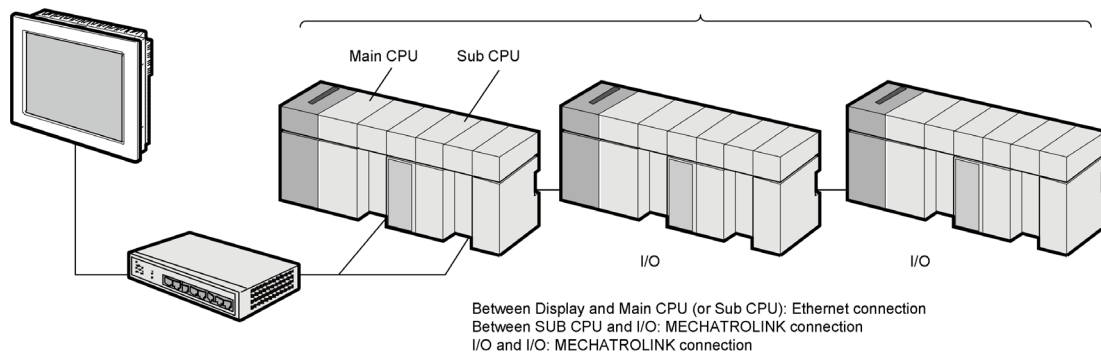

*1 When 33 or more External Devices are connected, it is necessary to check [Increase allowable number of Devices/PLCs].

☞ "4.1 Setup Items in GP-Pro EX" (page 157)

- Connection via Sub CPU and MPU-01

1:1 Connection

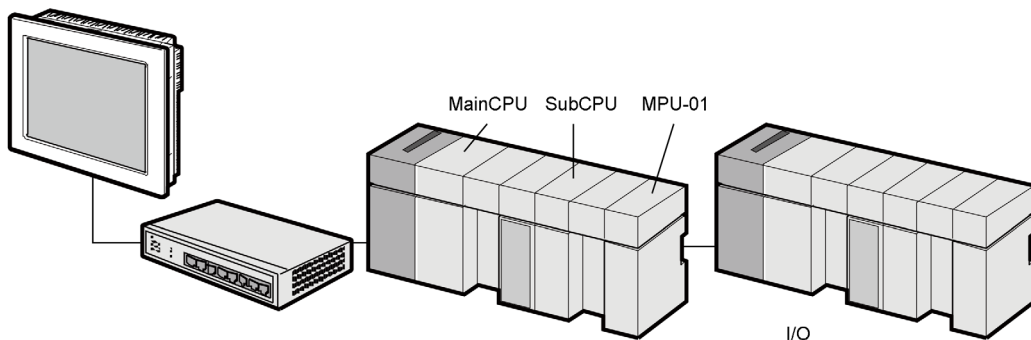

Between Display and Main CPU: Ethernet connection
 Between MPU-01 and I/O: MECHATROLINK connection

1:n Connection

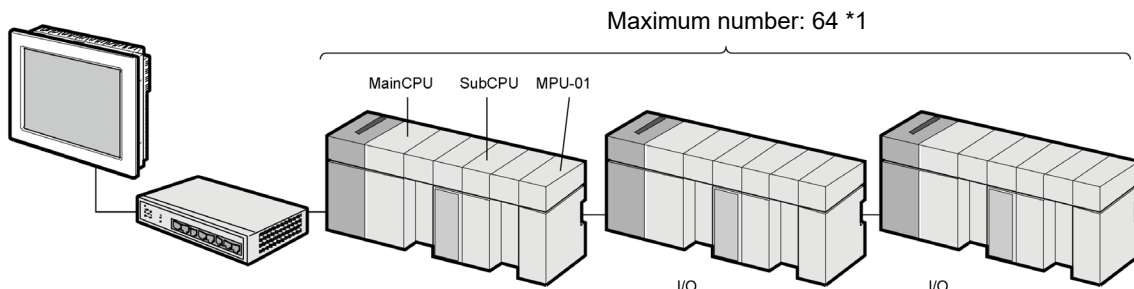

Between Display and Main CPU: Ethernet connection
 Between MPU-01 and I/O: MECHATROLINK connection
 I/O and I/O: MECHATROLINK connection

*1 When 33 or more External Devices are connected, it is necessary to check [Increase allowable number of Devices/PLCs].

☞ "4.1 Setup Items in GP-Pro EX" (page 157)

1.5 I/O(Azbil)

Series	CPU	Link I/F	SIO Type	Setting Example
Azbil Corporation K1G Series	K1G-C04M	MECHATROLINK Communications Connectors (CN6A/CN6B)	Ethernet (UDP) and MECHATROLINK-III	"3.28 Setting Example 28" (page 104)
		MECHATROLINK Communications Connectors on MPU-01	Ethernet (UDP) and MECHATROLINK-III	"3.29 Setting Example 29" (page 107)
		MECHATROLINK Communications Connectors on Sub CPU	Ethernet (UDP) and MECHATROLINK-III	"3.30 Setting Example 30" (page 110)

■ Connection Configuration

- 1:1 Connection

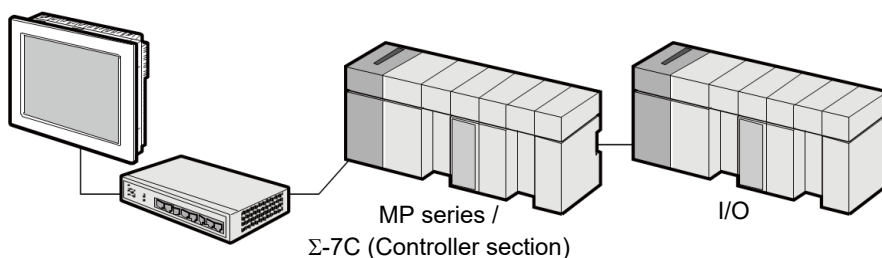

Between Display and MP series / Σ-7C (Controller section): Ethernet connection
 Between MP series / Σ-7C (Controller section) and I/O: MECHATROLINK connection

- 1:n Connection

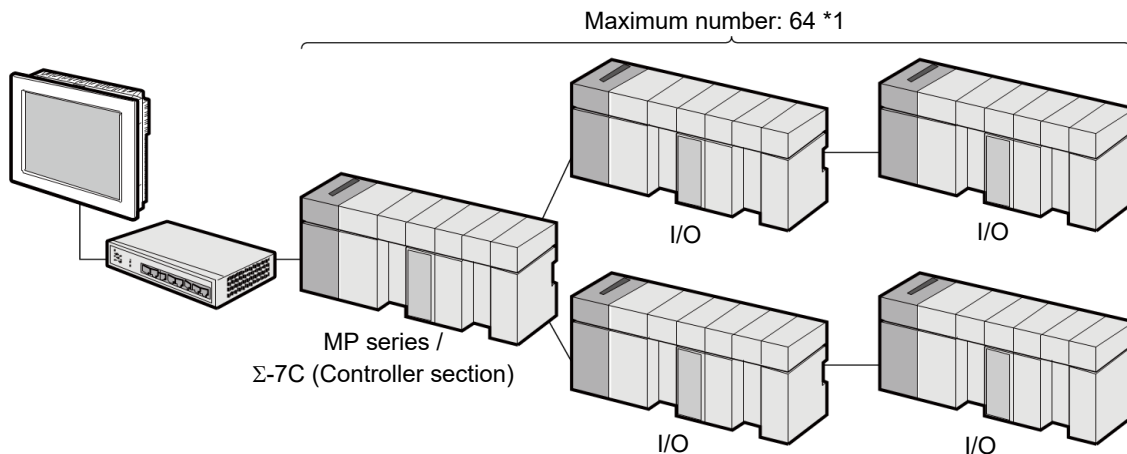

Between Display and MP series / Σ-7C (Controller section): Ethernet connection
 Between MP series / Σ-7C (Controller section) and I/O: MECHATROLINK connection
 Between I/O and I/O: MECHATROLINK connection

*1 When 33 or more External Devices are connected, it is necessary to check [Increase allowable number of Devices/PLCs].

☞ "4.1 Setup Items in GP-Pro EX" (page 157)

- Connection via MPU-01

1:1 Connection

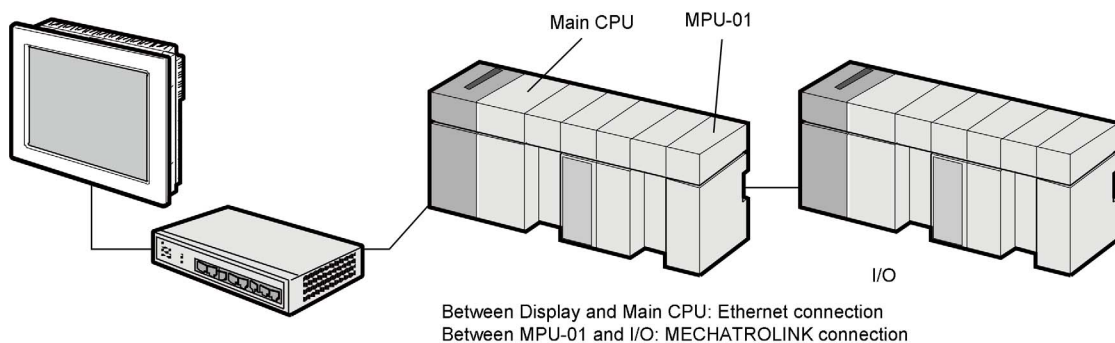

1:n Connection

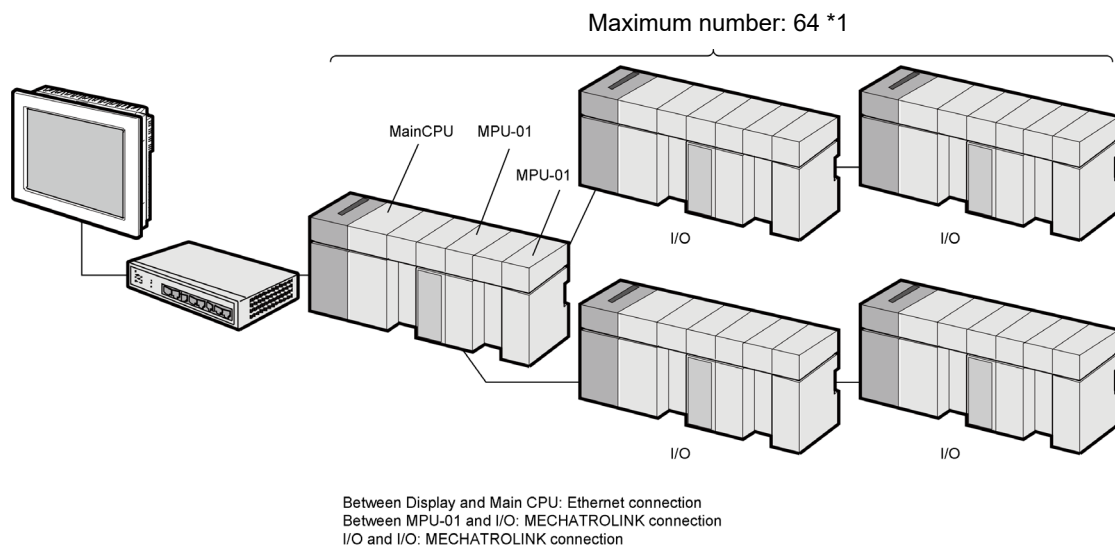

*1 When 33 or more External Devices are connected, it is necessary to check [Increase allowable number of Devices/PLCs].

☞ "4.1 Setup Items in GP-Pro EX" (page 157)

- Connection via Sub CPU

1:1 Connection

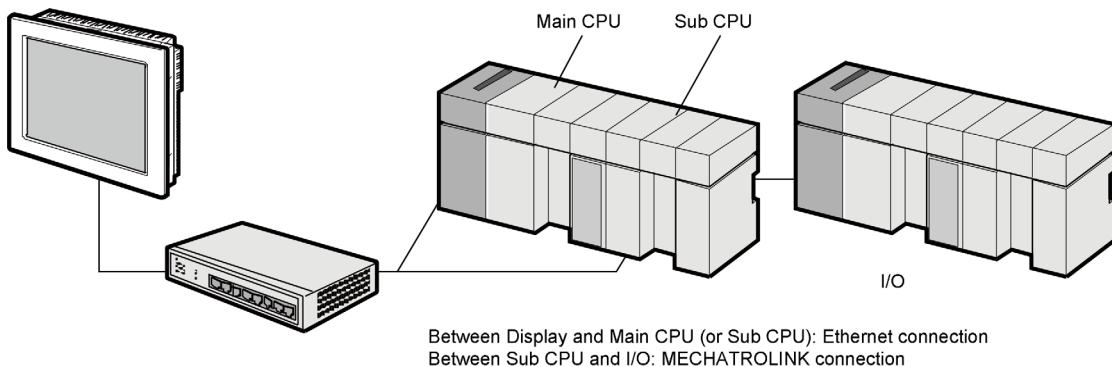

1:n Connection

Maximum number: 64 *1

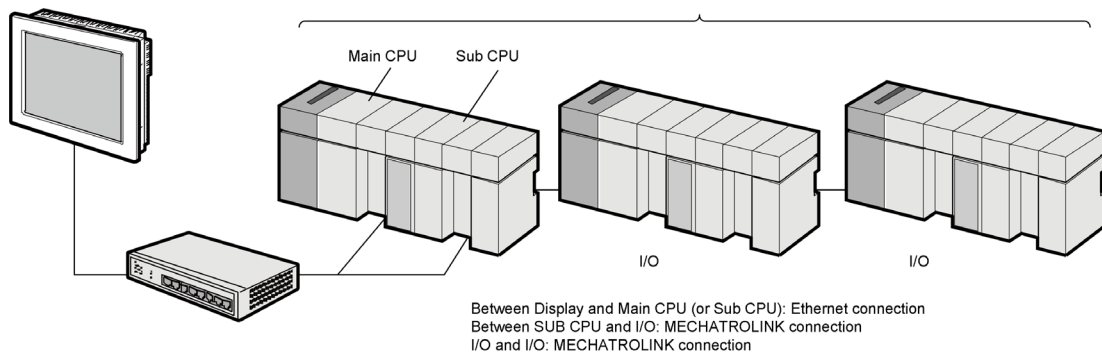

*1 When 33 or more External Devices are connected, it is necessary to check [Increase allowable number of Devices/PLCs].

☞ "4.1 Setup Items in GP-Pro EX" (page 157)

- Connection via Sub CPU and MPU-01

1:1 Connection

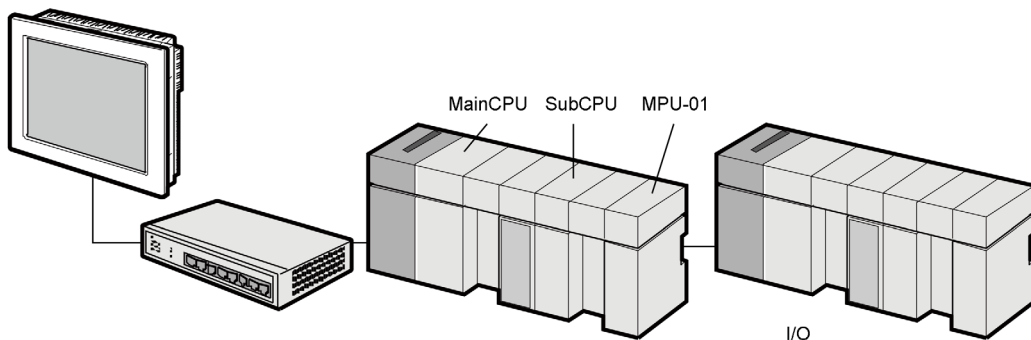

Between Display and Main CPU: Ethernet connection
 Between MPU-01 and I/O: MECHATROLINK connection

1:n Connection

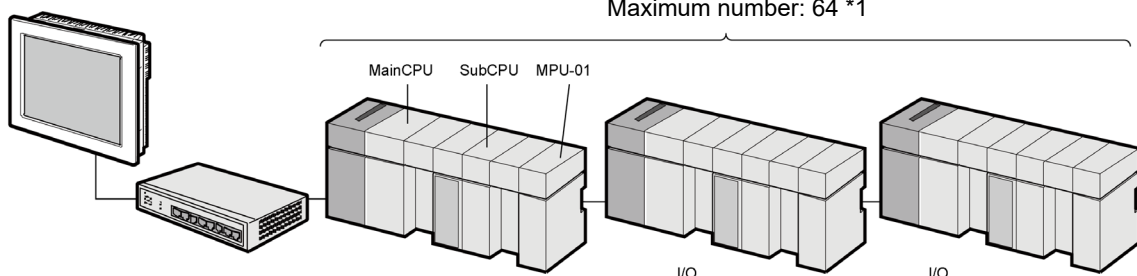

Between Display and Main CPU: Ethernet connection
 Between MPU-01 and I/O: MECHATROLINK connection
 I/O and I/O: MECHATROLINK connection

*1 When 33 or more External Devices are connected, it is necessary to check [Increase allowable number of Devices/PLCs].

☞ "4.1 Setup Items in GP-Pro EX" (page 157)

1.6 Stepping(Orientalmotor)

Series	CPU	Link I/F	SIO Type	Setting Example
ORIENTAL MOTOR Co., Ltd. AZ Series	AZD2A-KM3 AZD3A-KM3 AZD4A-KM3	MECHATROLINK Communications Connectors (CN6A/CN6B)	Ethernet (UDP) and MECHATROLINK-III	"3.31 Setting Example 31" (page 113)
		MECHATROLINK Communications Connectors on MPU-01	Ethernet (UDP) and MECHATROLINK-III	"3.32 Setting Example 32" (page 115)
		MECHATROLINK Communications Connectors on Sub CPU	Ethernet (UDP) and MECHATROLINK-III	"3.33 Setting Example 33" (page 118)

■ Connection Configuration

- 1:1 Connection

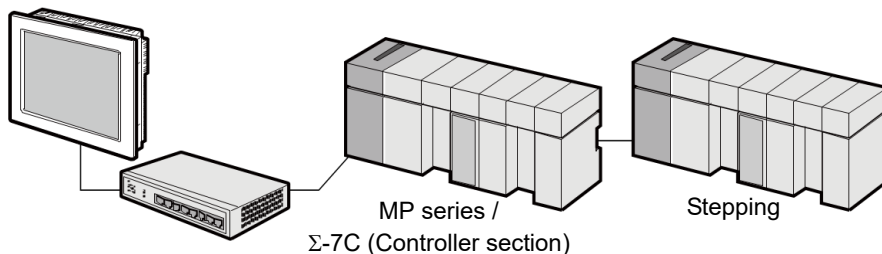

Between Display and MP series / Σ-7C (Controller section): Ethernet connection
 Between MP series / Σ-7C (Controller section) and Stepping: MECHATROLINK connection

- 1:n Connection

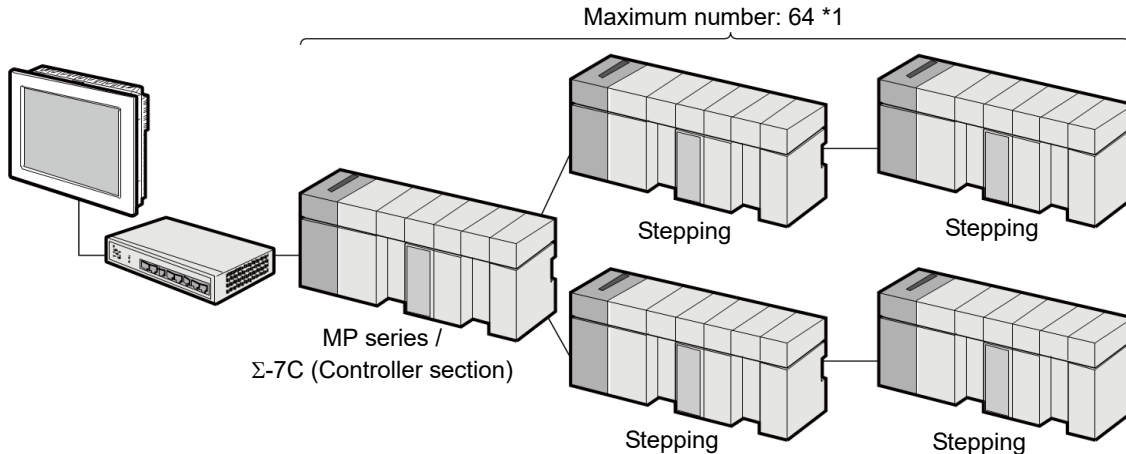

Between Display and MP series / Σ-7C (Controller section): Ethernet connection
 Between MP series / Σ-7C (Controller section) and Stepping: MECHATROLINK connection
 Between Stepping and Stepping: MECHATROLINK connection

*1 When 33 or more External Devices are connected, it is necessary to check [Increase allowable number of Devices/PLCs].

☞ "4.1 Setup Items in GP-Pro EX" (page 157)

- Connection via MPU-01

1:1 Connection

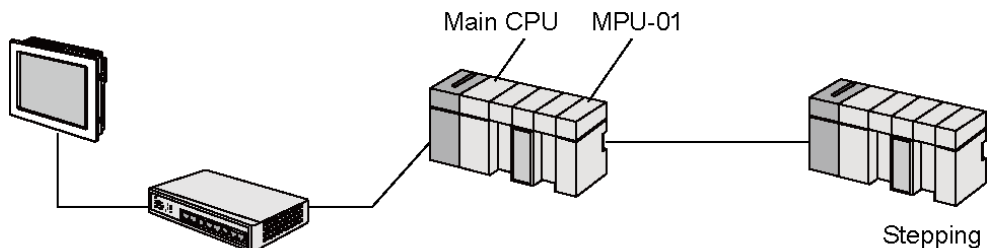

Between Display and Main CPU: Ethernet connection
 Between MPU-01 and Stepping: MECHATROLINK connection

1:n Connection

Maximum number: 64 *1

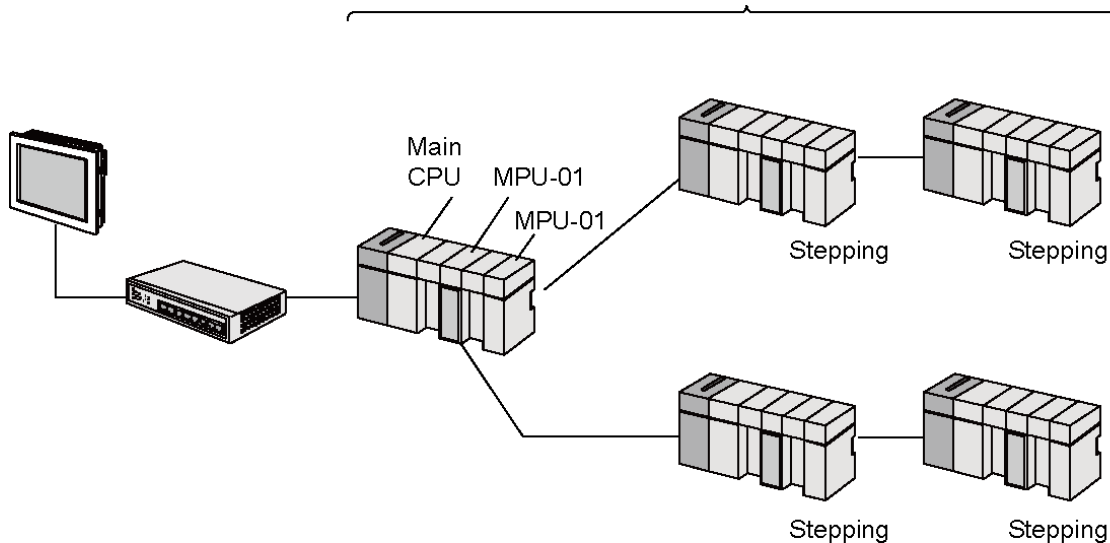

Between Display and Main CPU: Ethernet connection
 Between MPU-01 and Stepping: MECHATROLINK connection
 Stepping and Stepping: MECHATROLINK connection

*1 When 33 or more External Devices are connected, it is necessary to check [Increase allowable number of Devices/PLCs].

☞ "4.1 Setup Items in GP-Pro EX" (page 157)

- Connection via Sub CPU

1:1 Connection

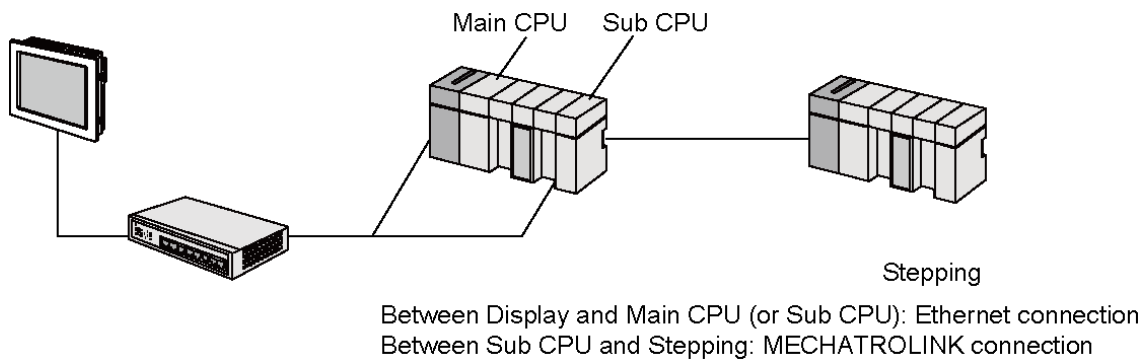

1:n Connection

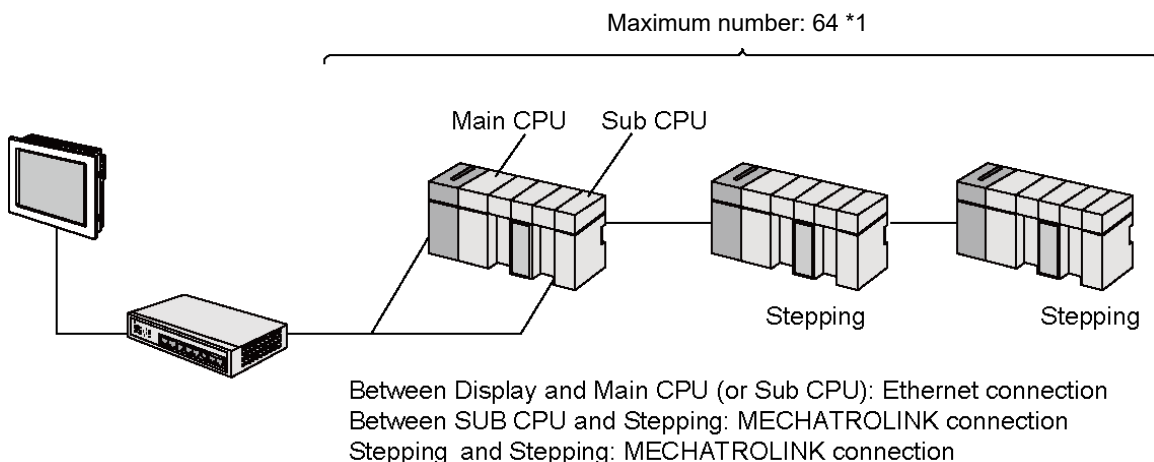

*1 When 33 or more External Devices are connected, it is necessary to check [Increase allowable number of Devices/PLCs].
 ☞ "4.1 Setup Items in GP-Pro EX" (page 157)

- Connection via Sub CPU and MPU-01

1:1 Connection

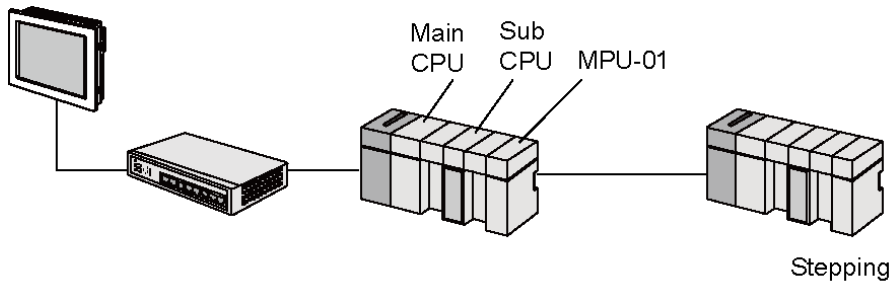

Between Display and Main CPU: Ethernet connection
 Between MPU-01 and Stepping: MECHATROLINK connection

1:n Connection

Maximum number: 64 *1

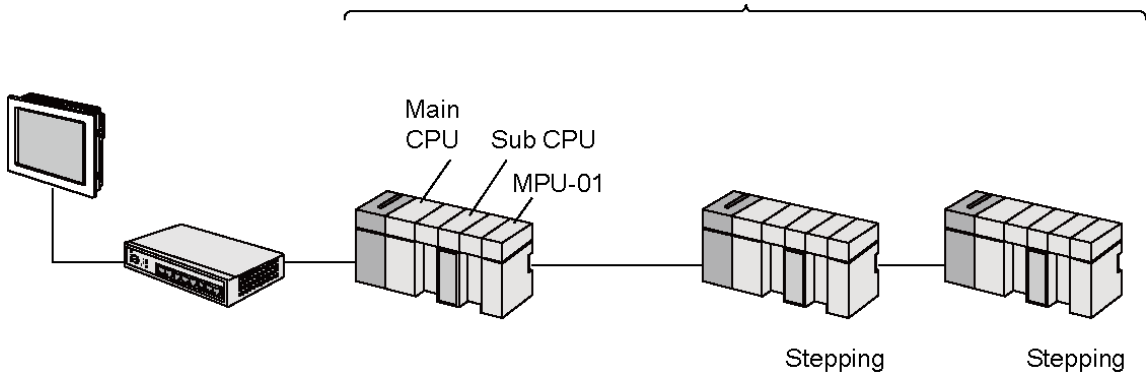

Between Display and Main CPU: Ethernet connection
 Between MPU-01 and Stepping: MECHATROLINK connection
 Stepping and Stepping: MECHATROLINK connection

*1 When 33 or more External Devices are connected, it is necessary to check [Increase allowable number of Devices/PLCs].

☞ "4.1 Setup Items in GP-Pro EX" (page 157)

2 External Device Selection

Select the External Device to be connected to the Display.

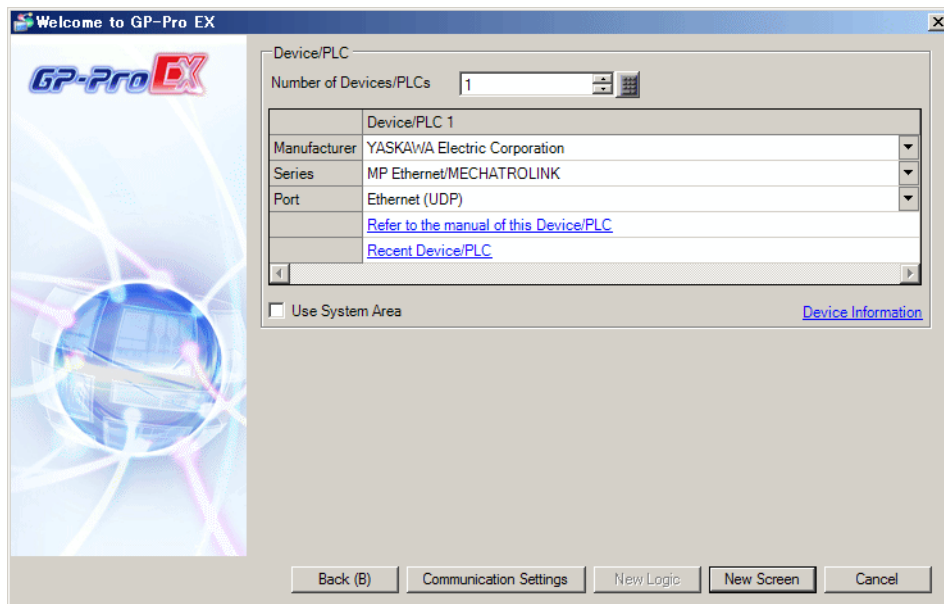

Setup Items	Setup Description
Number of Devices/PLCs	Use an integer from 1 to 4 to enter the number of Devices/PLCs to connect to the display.
Manufacturer	Select the manufacturer of the External Device to be connected. Select "YASKAWA Electric Corporation".
Series	Select a model (series) of the External Device to be connected and connection method. Select "MP Ethernet/MECHATROLINK". Check the External Device which can be connected in "MP Ethernet/MECHATROLINK" in system configuration. ☞ "1 System Configuration" (page 3)
Port	Select the Display port to be connected to the External Device.
Use System Area	Check this option to synchronize the system data area of the Display and the device (memory) of the External Device. When synchronized, you can use the External Device's ladder program to switch the display or display the window on the Display. Cf. GP-Pro EX Reference Manual "LS Area (Direct Access Method Area)" This feature can also be set in GP-Pro EX or in the Display's offline mode. Cf. GP-Pro EX Reference Manual "System Settings [Display Unit] - [System Area] Settings Guide" Cf. Maintenance/Troubleshooting Guide "Main Unit - System Area Settings"

3 Communication Settings

Examples of communication settings of the Display and the External Device, recommended by Pro-face, are shown.

3.1 Setting Example 1

■ Settings of GP-Pro EX

◆ Communication Settings

To display the setup screen, from the [Project] menu, point to [System Settings] and select [Device/PLC].

◆ Device Setting

To display the [Individual Device Settings] dialog box, from [Device-Specific Settings] in the [Device/PLC] window, select the External Device and click [Settings]. To connect multiple External Devices, from [Device-Specific Settings] in the [Device/PLC] window, click [Add Device] to add another External Device.

◆ Notes

- Check with a network administrator about IP address. Do not set the duplicate IP address.
- Set IP address on the External Device address in the [Individual Device Settings] dialog box.
- You need to set IP address on the Display in the offline mode of the Display.

■ Settings of External Device

Use the ladder software (MPE720) to set up communication settings for the communication module 218IF-01. For details on communication settings, please refer to the manual of the External Device. The setup procedure differs depending on the version of your ladder software.

◆ Ladder Software Setting (for MPE720 Ver.5)

- 1 Start the ladder software, and in the root folder make the order and PLC folders.
- 2 Right-click the generated External Device, and from the shortcut menu select Logon.

NOTE

- In the shortcut menu, please confirm there is no check mark beside the [Online] command before logging on.
- For methods on logging on, refer to the User's Manual of the External Device.

- 3 From the PLC folder, double-click the [Definition folder]'s [Module Configuration] to display the [Engineering Manager].
- 4 In the [Engineering Manager]'s [Controller], use the pull-down menu to select the rack classification and communication module.
Set the number associated with the slot number used by the communication module.
When you select the communication module, its setting information is displayed in the [Engineering Manager]'s [Module details].
- 5 In the [Module details], double-click the No. field's numeric portion.
Double-click the number associated with the slot number connected to the Ethernet unit.

Setup Items		Setup Description
Transmission parameter	This Station IP address	PLC IP address

IMPORTANT

- Please make the connection parameter blank.
Communication is not possible when a connection parameter is set.

- 6 Double-click "No.1" and set up serial communication.
Serial communication is used to transfer communication settings to the PLC.
- 7 Save the settings and exit [Engineering Manager].
- 8 After turning ON the communication module's "INIT" DIP Switch, turn ON the power supply.
- 9 Transfer the settings to the communication module.
- 10 While online, logon to the External Device. Write the transferred data to FLASH memory.
- 11 Turn OFF the External Device's power supply, turn OFF the "INIT" DIP Switch, and turn the External Device's power back ON.

◆ Ladder Software Setting (for MPE720 Ver.6)

- 1 Start the ladder software.
- 2 Make a project file.
- 3 From the tree view, double-click [Module Configuration].
[Engineering Manager] starts.
- 4 In the [Engineering Manager]'s [Controller], use the pull-down menu to select the rack classification and communication module.
Set the number associated with the slot number used by the communication module.
When you select the communication module, its setting information is displayed in the [Engineering Manager]'s [Module details].
- 5 In the [Module details], double-click the No. field's numeric portion.
Double-click the number associated with the slot number connected to the Ethernet unit.

Setup Items		Setup Description
Transmission parameter	This Station IP address	PLC IP address

IMPORTANT

- Please make the connection parameter blank.
Communication is not possible when a connection parameter is set.

- 6 Double-click "No.1" and set up serial communication.
Serial communication is used to transfer communication settings to the PLC.
- 7 Save the settings and exit [Engineering Manager].
- 8 After turning ON the communication module's "INIT" DIP Switch, turn ON the power supply.
- 9 Write the settings to the communication module.

IMPORTANT

- To write the settings, select the [Save to flash after transferring to the controller] check box.
If the data is transferred without selecting the check box, the transferred data is deleted when restarting the External Device.

- 10 Turn OFF the External Device's power supply, turn OFF the "INIT" DIP Switch, and turn the External Device's power back ON.

◆ Notes

- Check with a network administrator about IP address. Do not set the duplicate IP address.

3.2 Setting Example 2

■ Settings of GP-Pro EX

◆ Communication Settings

To display the setup screen, from the [Project] menu, point to [System Settings] and select [Device/PLC].

◆ Device Setting

To display the [Individual Device Settings] dialog box, from [Device-Specific Settings] in the [Device/PLC] window, select the External Device and click [Settings]. To connect multiple External Devices, from [Device-Specific Settings] in the [Device/PLC] window, click [Add Device] to add another External Device.

◆ Notes

- Check with a network administrator about IP address. Do not set the duplicate IP address.
- Set IP address on the External Device address in the [Individual Device Settings] dialog box.
- You need to set IP address on the Display in the offline mode of the Display.

■ Settings of External Device

Use the ladder software (MPE720) to set up communication settings for the communication module CPU unit. For details on communication settings, please refer to the manual of the External Device. The setup procedure differs depending on the version of your ladder software.

◆ Ladder Software Setting (for MPE720 Ver.5)

- 1 Start the ladder software, and in the root folder make the order and PLC folders.
- 2 Right-click the generated External Device, and from the shortcut menu select Logon.

NOTE

- In the shortcut menu, please confirm there is no check mark beside the [Online] command before logging on.
- For methods on logging on, refer to the User's Manual of the External Device.

- 3 From the PLC folder, double-click the [Definition folder]'s [Module Configuration] to display the [Engineering Manager].
- 4 In the [Engineering Manager]'s [Controller], use the pull-down menu to select the rack classification and communication module.
Set the number associated with the slot number used by the communication module.
When you select the communication module, its setting information is displayed in the [Engineering Manager]'s [Module details].
- 5 In the [Module details], double-click the No. field's numeric portion.
Double-click the number associated with the slot number connected to the Ethernet unit.

Setup Items		Setup Description
Transmission parameter	This Station IP address	PLC IP address

IMPORTANT

- Please make the connection parameter blank.
Communication is not possible when a connection parameter is set.

- 6 Save the settings and exit [Engineering Manager].
- 7 After turning ON the communication module's "INIT" DIP Switch, turn ON the power supply.
- 8 Transfer the settings to the communication module.
- 9 While online, logon to the External Device. Write the transferred data to FLASH memory.
- 10 Turn OFF the External Device's power supply, turn OFF the "INIT" DIP Switch, and turn the External Device's power back ON.

◆ Ladder Software Setting (for MPE720 Ver.6)

- 1 Start the ladder software.
- 2 Make a project file.
- 3 From the tree view, double-click [Module Configuration].
[Engineering Manager] starts.
- 4 In the [Engineering Manager]'s [Controller], use the pull-down menu to select the rack classification and communication module.
Set the number associated with the slot number used by the communication module.
When you select the communication module, its setting information is displayed in the [Engineering Manager]'s [Module details].
- 5 In the [Module details], double-click the No. field's numeric portion.
Double-click the number associated with the slot number connected to the Ethernet unit.

Setup Items		Setup Description
Transmission parameter	This Station IP address	PLC IP address

IMPORTANT

- Please make the connection parameter blank.
Communication is not possible when a connection parameter is set.

- 6 Save the settings and exit [Engineering Manager].
- 7 After turning ON the communication module's "INIT" DIP Switch, turn ON the power supply.
- 8 Write the settings to the communication module.

IMPORTANT

- To write the settings, select the [Save to flash after transferring to the controller] check box.
If the data is transferred without selecting the check box, the transferred data is deleted when restarting the External Device.

- 9 Turn OFF the External Device's power supply, turn OFF the "INIT" DIP Switch, and turn the External Device's power back ON.

◆ Notes

- Check with a network administrator about IP address. Do not set the duplicate IP address.

3.3 Setting Example 3

■ Settings of GP-Pro EX

◆ Communication Settings

To display the setup screen, from the [Project] menu, point to [System Settings] and select [Device/PLC].

◆ Device Setting

To display the [Individual Device Settings] dialog box, from [Device-Specific Settings] in the [Device/PLC] window, select the External Device and click [Settings]. To connect multiple External Devices, from [Device-Specific Settings] in the [Device/PLC] window, click [Add Device] to add another External Device.

◆ Notes

- Check with a network administrator about IP address. Do not set the duplicate IP address.
- Set IP address on the External Device address in the [Individual Device Settings] dialog box.
- You need to set IP address on the Display in the offline mode of the Display.

■ Settings of External Device

Use the ladder software (MPE720) to set up communication settings for the communication module 218IF-01. For details on communication settings, please refer to the manual of the External Device. The setup procedure differs depending on the version of your ladder software.

◆ Ladder Software Setting (for MPE720 Ver.5)

- 1 Start the ladder software, and in the root folder make the order and PLC folders.
- 2 Right-click the generated External Device, and from the shortcut menu select Logon.

NOTE

- In the shortcut menu, please confirm there is no check mark beside the [Online] command before logging on.
- For methods on logging on, refer to the User's Manual of the External Device.

- 3 From the PLC folder, double-click the [Definition folder]'s [Module Configuration] to display the [Engineering Manager].
- 4 In the [Engineering Manager]'s [Controller], use the pull-down menu to select the rack classification and communication module.
Set the number associated with the slot number used by the communication module.
When you select the communication module, its setting information is displayed in the [Engineering Manager]'s [Module details].
- 5 In the [Module details], double-click the No. field's numeric portion.
Double-click the number associated with the slot number connected to the Ethernet unit.

Setup Items		Setup Description
Transmission parameter	This Station IP address	PLC IP address

IMPORTANT

- Please make the connection parameter blank.
Communication is not possible when a connection parameter is set.

- 6 Save the settings and exit [Engineering Manager].
- 7 After turning ON the communication module's "INIT" DIP Switch, turn ON the power supply.
- 8 Transfer the settings to the communication module.
- 9 While online, logon to the External Device. Write the transferred data to FLASH memory.
- 10 Turn OFF the External Device's power supply, turn OFF the "INIT" DIP Switch, and turn the External Device's power back ON.

◆ Ladder Software Setting (for MPE720 Ver.6)

- 1 Start the ladder software.
- 2 Make a project file.
- 3 From the tree view, double-click [Module Configuration].
[Engineering Manager] starts.
- 4 In the [Engineering Manager]'s [Controller], use the pull-down menu to select the rack classification and communication module.
Set the number associated with the slot number used by the communication module.
When you select the communication module, its setting information is displayed in the [Engineering Manager]'s [Module details].
- 5 In the [Module details], double-click the No. field's numeric portion.
Double-click the number associated with the slot number connected to the Ethernet unit.

Setup Items		Setup Description
Transmission parameter	This Station IP address	PLC IP address

IMPORTANT

- Please make the connection parameter blank.
Communication is not possible when a connection parameter is set.

- 6 Save the settings and exit [Engineering Manager].
- 7 After turning ON the communication module's "INIT" DIP Switch, turn ON the power supply.
- 8 Write the settings to the communication module.

IMPORTANT

- To write the settings, select the [Save to flash after transferring to the controller] check box.
If the data is transferred without selecting the check box, the transferred data is deleted when restarting the External Device.

- 9 Turn OFF the External Device's power supply, turn OFF the "INIT" DIP Switch, and turn the External Device's power back ON.

◆ Notes

- Check with a network administrator about IP address. Do not set the duplicate IP address.

3.4 Setting Example 4

■ Settings of GP-Pro EX

◆ Communication Settings

To display the setup screen, from the [Project] menu, point to [System Settings] and select [Device/PLC].

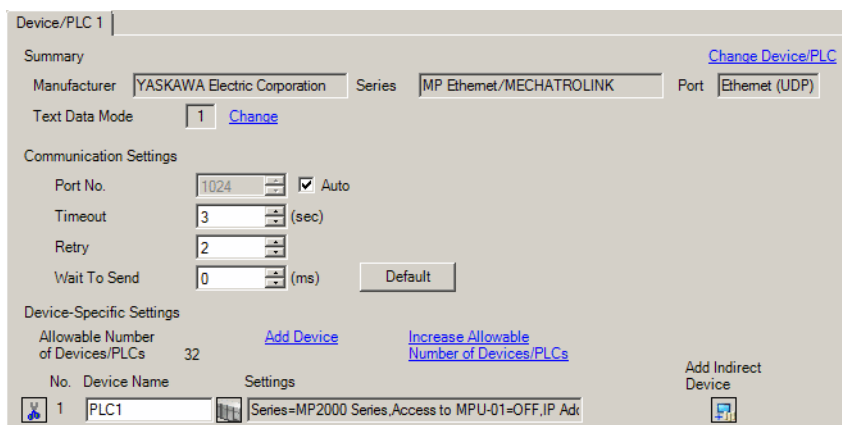

◆ Device Setting

To display the [Individual Device Settings] dialog box, from [Device-Specific Settings] in the [Device/PLC] window, select the External Device and click [Settings]. To connect multiple External Devices, from [Device-Specific Settings] in the [Device/PLC] window, click [Add Device] to add another External Device.

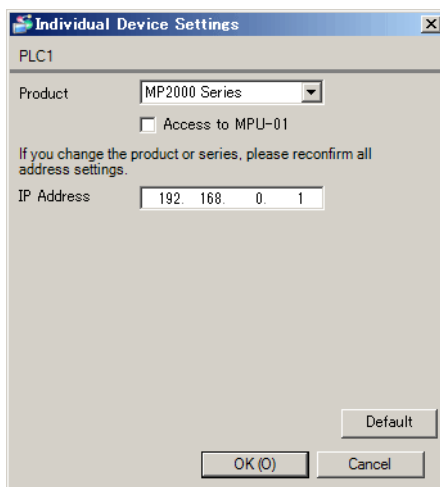

◆ Notes

- Check with a network administrator about IP address. Do not set the duplicate IP address.
- Set IP address on the External Device address in the [Individual Device Settings] dialog box.
- You need to set IP address on the Display in the offline mode of the Display.

■ Settings of External Device

Use the ladder software (MPE720) to set up communication settings for the communication module 218IF-01. For details on communication settings, please refer to the manual of the External Device. The setup procedure differs depending on the version of your ladder software.

◆ Ladder Software Setting (for MPE720 Ver.5)

- 1 Start the ladder software, and in the root folder make the order and PLC folders.
- 2 Right-click the generated External Device, and from the shortcut menu select Logon.

NOTE

- In the shortcut menu, please confirm there is no check mark beside the [Online] command before logging on.
- For methods on logging on, refer to the User's Manual of the External Device.

- 3 From the PLC folder, double-click the [Definition folder]'s [Module Configuration] to display the [Engineering Manager].
- 4 In the [Engineering Manager]'s [Controller], use the pull-down menu to select the rack classification and communication module.
Set the number associated with the slot number used by the communication module.
When you select the communication module, its setting information is displayed in the [Engineering Manager]'s [Module details].
- 5 In the [Module details], double-click the No. field's numeric portion.
Double-click the number associated with the slot number connected to the Ethernet unit.

Setup Items		Setup Description
Transmission parameter	This Station IP address	PLC IP address

IMPORTANT

- Please make the connection parameter blank.
Communication is not possible when a connection parameter is set.

- 6 Save the settings and exit [Engineering Manager].
- 7 After turning ON the communication module's "INIT" DIP Switch, turn ON the power supply.
- 8 Transfer the settings to the communication module.
- 9 While online, logon to the External Device. Write the transferred data to FLASH memory.
- 10 Turn OFF the External Device's power supply, turn OFF the "INIT" DIP Switch, and turn the External Device's power back ON.

◆ Ladder Software Setting (for MPE720 Ver.6)

- 1 Start the ladder software.
- 2 Make a project file.
- 3 From the tree view, double-click [Module Configuration].
[Engineering Manager] starts.
- 4 In the [Engineering Manager]'s [Controller], use the pull-down menu to select the rack classification and communication module.
Set the number associated with the slot number used by the communication module.
When you select the communication module, its setting information is displayed in the [Engineering Manager]'s [Module details].
- 5 In the in [Module details], double-click the No. field's numeric portion.
Double-click the number associated with the slot number connected to the Ethernet unit.

Setup Items		Setup Description
Transmission parameter	This Station IP address	PLC IP address

IMPORTANT

- Please make the connection parameter blank.
Communication is not possible when a connection parameter is set.

- 6 Save the settings and exit [Engineering Manager].
- 7 After turning ON the communication module's "INIT" DIP Switch, turn ON the power supply.
- 8 Write the settings to the communication module.

IMPORTANT

- To write the settings, select the [Save to flash after transferring to the controller] check box.
If the data is transferred without selecting the check box, the transferred data is deleted when restarting the External Device.

- 9 Turn OFF the External Device's power supply, turn OFF the "INIT" DIP Switch, and turn the External Device's power back ON.

◆ Notes

- Check with a network administrator about IP address. Do not set the duplicate IP address.

3.5 Setting Example 5

■ Settings of GP-Pro EX

◆ Communication Settings

To display the setup screen, from the [Project] menu, point to [System Settings] and select [Device/PLC].

IMPORTANT

- To connect Σ -V Series using a 1:n connection, [Wait To Send] must be 100ms or more.

◆ Device Setting

To display the [Individual Device Settings] dialog box, from [Device-Specific Settings] in the [Device/PLC] window, select the External Device and click [Settings]. To connect multiple External Devices, from [Device-Specific Settings] in the [Device/PLC] window, click [Add Device] to add another External Device.

◆ Notes

- Check with a network administrator about IP address. Do not set the duplicate IP address.
- Set IP address on the External Device address in the [Individual Device Settings] dialog box.
- You need to set IP address on the Display in the offline mode of the Display.

■ Settings of External Device

Set communication settings for both MP and Σ -V Series.

◆ MP Series Setting

Use the ladder software (MPE720) to set up communication settings.

For details on communication settings, please refer to the manual of the External Device.

1 Start the ladder software.

2 Make a project file.

3 From the tree view, double-click [Module Configuration].

[Engineering Manager] starts.

4 In the [Create new file] dialog box, click [OK].

5 In the [Engineering Manager]'s [Controller], use the pull-down menu to select MECHATROLINK connection module.

Select the number associated with the slot number used by the module.

When you select the MECHATROLINK connection module, its setting information is displayed in the [Engineering Manger]'s [Module details].

6 In the [module Details]'s [Circuit Number] field, enter "01".

Set up the same value as the Display's circuit number.

7 In [Details], double-click [MECHATROLINK].

8 Click the [Link Assignments] tab, and then set [ST#]'s [01] field as follows.

Setup Items	Setup Description
TYPE	Select the type of Σ -V Series you are using.

NOTE

- [ST#] is defined based on the Σ -V Series station address.
When the station address is 41H, define "ST#01".

9 In the [Engineering Manager]'s [Controller], select CPU.

10 In the [Module details], double-click the communication module's No. field.

11 Set [Transmission Parameters] as follows.

Setup Items	Setup Description
IP Address	192.168.0.1
Subnet Mask	255.255.255.0

12 From the [File] menu select [Save] to save your settings, and exit [Engineering Manager].

13 Write the settings to the MP Series.

IMPORTANT

- To write the settings, select the [Save to flash after transferring to the controller] check box.
If the data is transferred without selecting the check box, the transferred data is deleted when restarting the External Device.

◆ Σ -V Series Setting

Set up communication settings with the DIP Switch (SW2) and the rotary switch (SW1). For example, when the SW2-3 is OFF and SW1 is 1, the station address is 41H.

For details on communication settings, please refer to the manual for the External Device.

- DIP Switch (SW2) Setting

DIP Switch	Settings	Setup Description
1	ON	Communication speed: 10Mbps (MECHATROLINK-II)
2	Optional	Data transfer size. ON: 32-byte data transfer OFF: 17-byte data transfer
3	OFF	Define the station address in combination with the rotary switch (SW1). ON: Tenth's position of station address is 0x5 OFF: Tenth's position of station address is 0x4
4	OFF	Always OFF

- Rotary Switch (SW1) Setting

Set the station address in combination with the DIP Switch (SW2), number 3.

Rotary Switch	Settings	Setup Description
SW1	1	Ones place of the station address

◆ Notes

- Check with a network administrator about IP address. Do not set the duplicate IP address.

3.6 Setting Example 6

■ Settings of GP-Pro EX

◆ Communication Settings

To display the setup screen, from the [Project] menu, point to [System Settings] and select [Device/PLC].

IMPORTANT

- To connect Σ -V Series using a 1:n connection, [Wait To Send] must be 100ms or more.

◆ Device Setting

To display the [Individual Device Settings] dialog box, from [Device-Specific Settings] in the [Device/PLC] window, select the External Device and click [Settings]. To connect multiple External Devices, from [Device-Specific Settings] in the [Device/PLC] window, click [Add Device] to add another External Device.

◆ Notes

- Check with a network administrator about IP address. Do not set the duplicate IP address.
- Set IP address on the External Device address in the [Individual Device Settings] dialog box.
- You need to set IP address on the Display in the offline mode of the Display.

■ Settings of External Device

Set communication settings for both MP and Σ -V Series.

◆ MP Series Setting

Use the ladder software (MPE720) to set up communication settings.

For details on communication settings, please refer to the manual of the External Device.

- 1 Start the ladder software.
- 2 Make a project file.
- 3 From the tree view, double-click [Module Configuration].
[Engineering Manager] starts.
- 4 In the [Create new file] dialog box, click [OK].
- 5 In the [Engineering Manager]'s [Controller], use the pull-down menu to select MECHATROLINK connection module.

Select the number associated with the slot number used by the module.

When you select the MECHATROLINK connection module, its setting information is displayed in the [Engineering Manger]'s [Module details].

- 6 In the [module Details]'s [Circuit Number] field, enter "01".
Set up the same value as the Display's circuit number.
- 7 In [Details], double-click [MECHATROLINK].
- 8 Click the [Link Assignments] tab, and then set [ST#]'s [01] field as follows.

Setup Items	Setup Description
TYPE	Select the type of Σ -V Series you are using.

NOTE

- [ST#] is defined based on the Σ -V Series station address.
When the station address is 41H, define "ST#01".

- 9 In the [Engineering Manager]'s [Controller], select CPU.
- 10 In the [Module details], double-click the communication module's No. field.
- 11 Set [Transmission Parameters] as follows.

Setup Items	Setup Description
IP Address	192.168.0.1
Subnet Mask	255.255.255.0

- 12 From the [File] menu select [Save] to save your settings, and exit [Engineering Manager].
- 13 Write the settings to the MP Series.

IMPORTANT

- To write the settings, select the [Save to flash after transferring to the controller] check box.
If the data is transferred without selecting the check box, the transferred data is deleted when restarting the External Device.

◆ Σ -V Series Setting

Set up communication settings with the DIP Switch (SW2) and the rotary switch (SW1). For example, when the SW2-3 is OFF and SW1 is 1, the station address is 41H.

For details on communication settings, please refer to the manual for the External Device.

- DIP Switch (SW2) Setting

DIP Switch	Settings	Setup Description
1	ON	Communication speed: 10Mbps (MECHATROLINK-II)
2	Optional	Data transfer size. ON: 32-byte data transfer OFF: 17-byte data transfer
3	OFF	Define the station address in combination with the rotary switch (SW1). ON: Tenth's position of station address is 0x5 OFF: Tenth's position of station address is 0x4
4	OFF	Always OFF

- Rotary Switch (SW1) Setting

Set the station address in combination with the DIP Switch (SW2), number 3.

Rotary Switch	Settings	Setup Description
SW1	1	Ones place of the station address

◆ Notes

- Check with a network administrator about IP address. Do not set the duplicate IP address.

3.7 Setting Example 7

■ Settings of GP-Pro EX

◆ Communication Settings

To display the setup screen, from the [Project] menu, point to [System Settings] and select [Device/PLC].

IMPORTANT

- To connect Σ -V Series using a 1:n connection, [Wait To Send] must be 100ms or more.

◆ Device Setting

To display the [Individual Device Settings] dialog box, from [Device-Specific Settings] in the [Device/PLC] window, select the External Device and click [Settings]. To connect multiple External Devices, from [Device-Specific Settings] in the [Device/PLC] window, click [Add Device] to add another External Device.

◆ Notes

- Check with a network administrator about IP address. Do not set the duplicate IP address.
- Set IP address on the External Device address in the [Individual Device Settings] dialog box.
- You need to set IP address on the Display in the offline mode of the Display.

■ Settings of External Device

Set communication settings for both MP and Σ -V Series.

◆ MP Series Setting

Use the ladder software (MPE720) to set up communication settings.

For details on communication settings, please refer to the manual of the External Device.

1 Start the ladder software.

2 Make a project file.

3 From the tree view, double-click [Module Configuration].

[Engineering Manager] starts.

4 In the [Create new file] dialog box, click [OK].

5 In the [Engineering Manager]'s [Controller], use the pull-down menu to select MECHATROLINK connection module.

Select the number associated with the slot number used by the module.

When you select the MECHATROLINK connection module, its setting information is displayed in the [Engineering Manger]'s [Module details].

6 In the [module Details]'s [Circuit Number] field, enter "01".

Set up the same value as the Display's circuit number.

7 In [Details], double-click [MECHATROLINK].

8 Click the [Link Assignments] tab, and then [ST#]'s [01] as follows.

Setup Items	Setup Description
ADR	03H
ExADR	00
VENDOR	Yaskawa Electric co.
DEVICE	Σ -V Series type

NOTE

- [PROFILE], [BYTE] and [SCAN] are defined automatically.

9 In the [Engineering Manager]'s [Controller], select CPU.

10 In the [Module details], double-click the communication module's No. field.

11 Set [Transmission Parameters] as follows.

Setup Items	Setup Description
IP Address	192.168.0.1
Subnet Mask	255.255.255.0

12 From the [File] menu select [Save] to save your settings, and exit [Engineering Manager].

13 Write the settings to MP Series.

IMPORTANT

- To write the settings, select the [Save to flash after transferring to the controller] check box.
If the data is transferred without selecting the check box, the transferred data is deleted when restarting the External Device.

◆ Σ -V Series Setting

Set up communication settings with rotary switches (S1 and S2).

For details on communication settings, please refer to the manual of the External Device.

Rotary Switch	Settings	Setup Description
S1 (x16)	0	Station address
S2 (x1)	3	

◆ Notes

- Check with a network administrator about IP address. Do not set the duplicate IP address.

3.8 Setting Example 8

■ Settings of GP-Pro EX

◆ Communication Settings

To display the setup screen, from the [Project] menu, point to [System Settings] and select [Device/PLC].

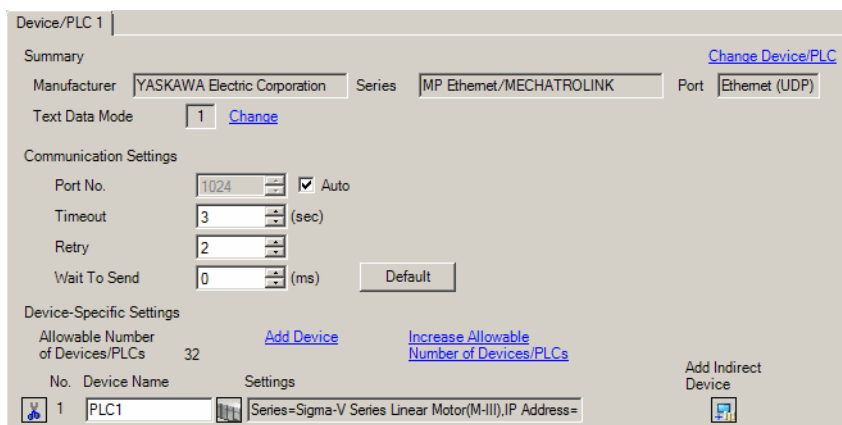

IMPORTANT

- To connect Σ -V Series using a 1:n connection, [Wait To Send] must be 100ms or more.

◆ Device Setting

To display the [Individual Device Settings] dialog box, from [Device-Specific Settings] in the [Device/PLC] window, select the External Device and click [Settings]. To connect multiple External Devices, from [Device-Specific Settings] in the [Device/PLC] window, click [Add Device] to add another External Device.

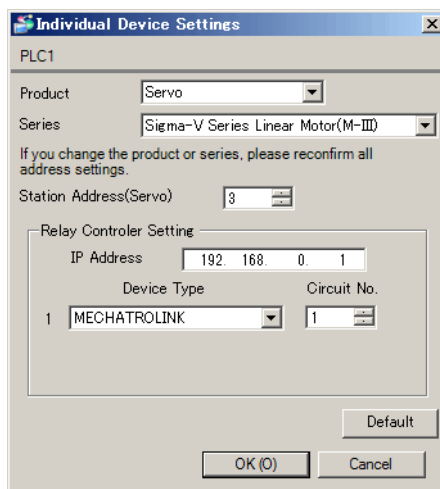

◆ Notes

- Check with a network administrator about IP address. Do not set the duplicate IP address.
- Set IP address on the External Device address in the [Individual Device Settings] dialog box.
- You need to set IP address on the Display in the offline mode of the Display.

■ Settings of External Device

Set communication settings for both MP and Σ -V Series.

◆ MP Series Setting

Use the ladder software (MPE720) to set up communication settings.

For details on communication settings, please refer to the manual of the External Device.

- 1 Start the ladder software.
- 2 Make a project file.
- 3 From the tree view, double-click [Module Configuration].
[Engineering Manager] starts.
- 4 In the [Create new file] dialog box, click [OK].
- 5 In the [Engineering Manager]'s [Controller], use the pull-down menu to select MECHATROLINK connection module.
Select the number associated with the slot number used by the module.
When you select the MECHATROLINK connection module, its setting information is displayed in the [Engineering Manger]'s [Module details].
- 6 In the [module Details]'s [Circuit Number] field, enter "01".
Set up the same value as the Display's circuit number.
- 7 In [Details], double-click [MECHATROLINK].
- 8 Click the [Link Assignments] tab, and then [ST#]'s [01] as follows.

Setup Items	Setup Description
ADR	03H
ExADR	00
VENDOR	Yaskawa Electric co.
DEVICE	Σ -V Series type

NOTE

- [PROFILE], [BYTE] and [SCAN] are defined automatically.

- 9 In the [Engineering Manager]'s [Controller], select CPU.
- 10 In the [Module details], double-click the communication module's No. field.
- 11 Set [Transmission Parameters] as follows.

Setup Items	Setup Description
IP Address	192.168.0.1
Subnet Mask	255.255.255.0

- 12 From the [File] menu select [Save] to save your settings, and exit [Engineering Manager].
- 13 Write the settings to MP Series.

IMPORTANT

- To write the settings, select the [Save to flash after transferring to the controller] check box.
If the data is transferred without selecting the check box, the transferred data is deleted when restarting the External Device.

◆ Σ -V Series Setting

Set up communication settings with rotary switches (S1 and S2).

For details on communication settings, please refer to the manual of the External Device.

Rotary Switch	Settings	Setup Description
S1 (x16)	0	Station address
S2 (x1)	3	

◆ Notes

- Check with a network administrator about IP address. Do not set the duplicate IP address.

3.9 Setting Example 9

■ Settings of GP-Pro EX

◆ Communication Settings

To display the setup screen, from the [Project] menu, point to [System Settings] and select [Device/PLC].

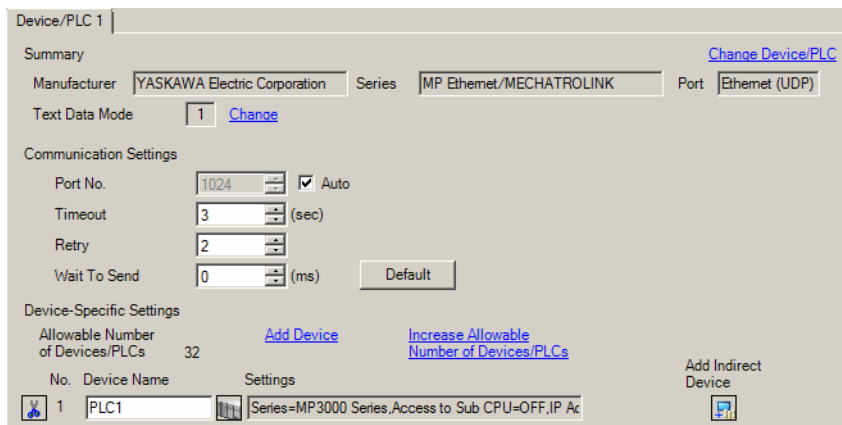

◆ Device Setting

To display the [Individual Device Settings] dialog box, from [Device-Specific Settings] in the [Device/PLC] window, select the External Device and click [Settings]. To connect multiple External Devices, from [Device-Specific Settings] in the [Device/PLC] window, click [Add Device] to add another External Device.

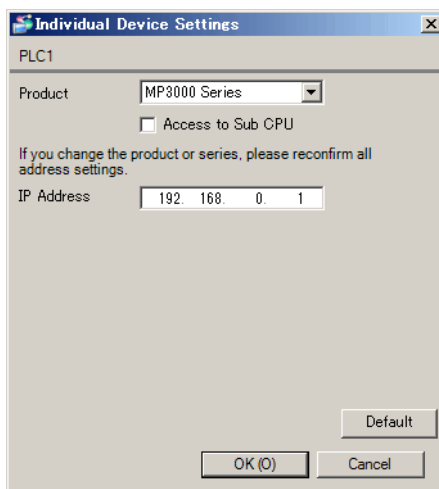

◆ Notes

- Check with a network administrator about IP address. Do not set the duplicate IP address.
- Set IP address on the External Device address in the [Individual Device Settings] dialog box.
- You need to set the Display's IP address in its offline mode.

■ Settings of External Device

Use the ladder software (MP720 Ver.7) to set up communication settings.

For details on communication settings, please refer to the manual of the External Device.

- 1 Start the ladder software.
- 2 Make a project file.
- 3 Click [Module Configuration] to start [MC-Configurator].
- 4 Double-click [218IFD] on the CPU you want to use.
- 5 Click the [Transmission Parameters] tab.
- 6 In the [Transmission Parameters], set the [IP Address] and [Subnet Mask].

Setup Items	Setup Description
IP Address	192.168.0.1
Subnet Mask	255.255.255.0

- 7 Write the settings to the External Device.
- 8 Turn ON the External Device again.

◆ Notes

- Check with a network administrator about IP address. Do not set the duplicate IP address.

3.10 Setting Example 10

■ Settings of GP-Pro EX

◆ Communication Settings

To display the setup screen, from the [Project] menu, point to [System Settings] and select [Device/PLC].

◆ Device Setting

To display the [Individual Device Settings] dialog box, from [Device-Specific Settings] in the [Device/PLC] window, select the External Device and click [Settings]. To connect multiple External Devices, from [Device-Specific Settings] in the [Device/PLC] window, click [Add Device] to add another External Device.

◆ Notes

- Check with a network administrator about IP address. Do not set the duplicate IP address.
- Set IP address on the External Device address in the [Individual Device Settings] dialog box.
- You need to set the Display's IP address in offline mode.

■ Settings of External Device

For details on communication settings, please refer to the manual of the External Device.

◆ Setup Procedure

- 1 Press UP to display the Parameter Setting Mode screen. Press ENTER to change to Set Up Mode.
- 2 Press UP to display setup items. Press ENTER key to change to setup screen.
- 3 Press UP or RESET to select the setup value. Press ENTER to set up a description.

◆ Setup Description

Setup Items	Setup value	Description
b1-02 ^{*1}	3	Run Command Selection (Option Card)
F6-20	21	MECHATROLINK station address
F6-22	0	MECHATROLINK link rate (10Mbps)

*1 Set b1-01 to 3 when you set the frequency via MECHATROLINK.

3.11 Setting Example 11

■ Settings of GP-Pro EX

◆ Communication Settings

To display the setup screen, from the [Project] menu, point to [System Settings] and select [Device/PLC].

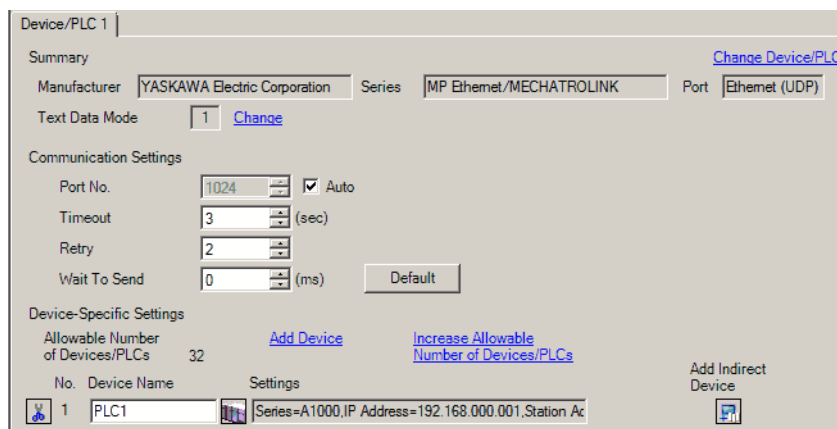

◆ Device Setting

To display the [Individual Device Settings] dialog box, from [Device-Specific Settings] in the [Device/PLC] window, select the External Device and click [Settings]. To connect multiple External Devices, from [Device-Specific Settings] in the [Device/PLC] window, click [Add Device] to add another External Device.

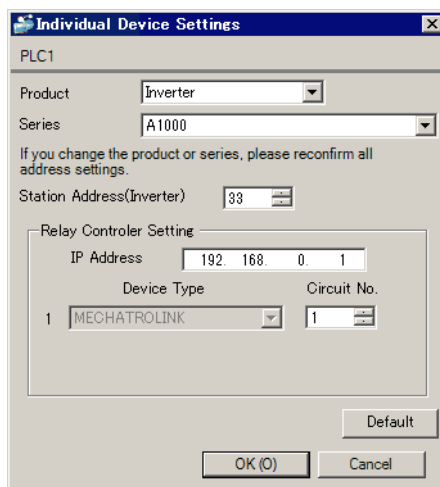

◆ Notes

- Check with a network administrator about IP address. Do not set the duplicate IP address.
- Set IP address on the External Device address in the [Individual Device Settings] dialog box.
- You need to set the Display's IP address in offline mode.

■ Settings of External Device

For details on communication settings, please refer to the manual of the External Device.

◆ Setup Procedure

- 1 Press UP to display the Parameter Setting Mode screen. Press ENTER to change to Set Up Mode.
- 2 Press UP to display setup items. Press ENTER key to change to setup screen.
- 3 Press UP or RESET to select the setup value. Press ENTER to set up a description.

◆ Setup Description

Setup Items	Setup value	Description
b1-02 ^{*1}	3	Run Command Selection (Option Card)
F6-20	21	MECHATROLINK station address
F6-22	0	MECHATROLINK link rate (10Mbps)

*1 Set b1-01 to 3 when you set the frequency via MECHATROLINK.

3.12 Setting Example 12

■ Settings of GP-Pro EX

◆ Communication Settings

To display the setup screen, from the [Project] menu, point to [System Settings] and select [Device/PLC].

◆ Device Setting

To display the [Individual Device Settings] dialog box, from [Device-Specific Settings] in the [Device/PLC] window, select the External Device and click [Settings]. To connect multiple External Devices, from [Device-Specific Settings] in the [Device/PLC] window, click [Add Device] to add another External Device.

◆ Notes

- Check with a network administrator about IP address. Do not set the duplicate IP address.
- Set IP address on the External Device address in the [Individual Device Settings] dialog box.
- You need to set IP address on the Display in the offline mode of the Display.

■ Settings of External Device

Use the ladder software (MP720 Ver.7) to set up communication settings.

For details on communication settings, please refer to the manual of the External Device.

- 1 Start the ladder software.
- 2 Make a project file. Select the main CPU models from [Model].
- 3 From the tree view, double-click [Module Configuration].
[MC-Configurator] starts.
- 4 Double-click [218IFD] on the CPU to use.
- 5 Click [Parameters] tab.
- 6 Set "IP Address" and "Subnet Mask" of "Transmission Parameters".

Setup Items	Setup Description
IP Address	192.168.0.1
Subnet Mask	255.255.255.0

- 7 Double-click the module number corresponding to the option slot which attaches MPU-01 in the [MC-Configurator]
- 8 Select [MPU-01] in the [Module] dialog box, and click [OK].
- 9 Set "3" to the circuit number of MPU-01 that displayed in the [MC-Configurator].
Set up the same value as the Display's circuit number.
- 10 Write the settings to the External Device.

IMPORTANT

- To write the settings, select the [Save to flash after transferring to the controller] check box.
If the data is transferred without selecting the check box, the transferred data is deleted when restarting the External Device.

◆ Notes

- Check with a network administrator about IP address. Do not set the duplicate IP address.

3.13 Setting Example 13

■ Settings of GP-Pro EX

◆ Communication Settings

To display the setup screen, from the [Project] menu, point to [System Settings] and select [Device/PLC].

Device/PLC 1

Summary [Change Device/PLC](#)

Manufacturer Series Port

Text Data Mode [Change](#)

Communication Settings

Port No. Auto

Timeout (sec)

Retry

Wait To Send (ms)

Device-Specific Settings

Allowable Number of Devices/PLCs 32 [Add Device](#) [Increase Allowable Number of Devices/PLCs](#)

No.	Device Name	Settings	Add Indirect Device
1	PLC1	Series=Sigma-V Series Rotational Motor(M-III),IP Adde	<input type="button" value="Add"/>

◆ Device Setting

To display the [Individual Device Settings] dialog box, from [Device-Specific Settings] in the [Device/PLC] window, select the External Device and click [Settings]. To connect multiple External Devices, from [Device-Specific Settings] in the [Device/PLC] window, click [Add Device] to add another External Device.

Individual Device Settings

PLC1

Product

Series

If you change the product or series, please reconfirm all address settings.

Station Address(Servo)

Relay Controller Setting

IP Address

	Device Type	Circuit No.
1	<input type="text" value="MPU-01"/>	<input type="text" value="3"/>
2	<input type="text" value="MECHATROLINK"/>	<input type="text" value="1"/>

◆ Notes

- Check with a network administrator about IP address. Do not set the duplicate IP address.
- Set IP address on the External Device address in the [Individual Device Settings] dialog box.
- You need to set IP address on the Display in the offline mode of the Display.

■ Settings of External Device

Use the ladder software (MP720 Ver.7) to set up communication settings. Set the next contents.

- (1) Main CPU settings
- (2) MPU-01 settings
- (3) Σ -Vseries settings

For details on communication settings, please refer to the manual of the External Device.

◆ Main CPU Settings

- 1 Start the ladder software.
- 2 Make a project file. Select the main CPU models from [Model].
- 3 From the tree view, double-click [Module Configuration].
[MC-Configurator] starts.
- 4 Double-click [218IFD] on the CPU to use.
- 5 Click [Parameters] tab.
- 6 Set "IP Address" and "Subnet Mask" of "Transmission Parameters".

Setup Items	Setup Description
IP Address	192.168.0.1
Subnet Mask	255.255.255.0

- 7 Double-click the module number corresponding to the option slot which attaches MPU-01 in the [MC-Configurator]
- 8 Select [MPU-01] in the [Module] dialog box, and click [OK].
- 9 Set "3" to the circuit number of MPU-01 that displayed in the [MC-Configurator].
Set up the same value as the Display's circuit number.
- 10 Write the settings to the External Device.

IMPORTANT • To write the settings, select the [Save to flash after transferring to the controller] check box.
If the data is transferred without selecting the check box, the transferred data is deleted when restarting the External Device.

◆ MPU-01 Settings

- 1 Start the ladder software.
- 2 Make a project file. Select "MPU-01" from [Model].
- 3 From the tree view, double-click [Module Configuration].
[MC-Configurator] starts.
- 4 Expand [SVC] of [MPU-01] module, and double-click [01 UNDEFINED].
- 5 Select the using Σ -V series of [Slave] dialog box, and click [OK].
- 6 Set "1" to the circuit number of [SVC].
- 7 Set "3" to the station address of the added V-series.

8 Write the settings to the MPU-01 series.

IMPORTANT

- To write the settings, select the [Save to flash after transferring to the controller] check box.
If the data is transferred without selecting the check box, the transferred data is deleted when restarting the External Device.

◆ Σ -V Series Setting

Set up communication settings with rotary switches (S1 and S2).

For details on communication settings, please refer to the manual of the External Device.

Rotary Switch	Settings	Setup Description
S1 (x16)	0	Station address
S2 (x1)	3	

◆ Notes

- Check with a network administrator about IP address. Do not set the duplicate IP address.

3.14 Setting Example 14

■ Settings of GP-Pro EX

◆ Communication Settings

To display the setup screen, from the [Project] menu, point to [System Settings] and select [Device/PLC].

◆ Device Setting

To display the [Individual Device Settings] dialog box, from [Device-Specific Settings] in the [Device/PLC] window, select the External Device and click [Settings]. To connect multiple External Devices, from [Device-Specific Settings] in the [Device/PLC] window, click [Add Device] to add another External Device.

◆ Notes

- Check with a network administrator about IP address. Do not set the duplicate IP address.
- Set IP address on the External Device address in the [Individual Device Settings] dialog box.
- You need to set IP address on the Display in the offline mode of the Display.

■ Settings of External Device

Use the ladder software (MP720 Ver.7) to set up communication settings. Set the next contents.

- (1) Main CPU settings
- (2) MPU-01 settings
- (3) Σ -Vseries settings

For details on communication settings, please refer to the manual of the External Device.

◆ Main CPU Settings

- 1 Start the ladder software.
- 2 Make a project file. Select the main CPU models from [Model].
- 3 From the tree view, double-click [Module Configuration].
[MC-Configurator] starts.
- 4 Double-click [218IFD] on the CPU to use.
- 5 Click [Parameters] tab.
- 6 Set "IP Address" and "Subnet Mask" of "Transmission Parameters".

Setup Items	Setup Description
IP Address	192.168.0.1
Subnet Mask	255.255.255.0

- 7 Double-click the module number corresponding to the option slot which attaches MPU-01 in the [MC-Configurator]
- 8 Select [MPU-01] in the [Module] dialog box, and click [OK].
- 9 Set "3" to the circuit number of MPU-01 that displayed in the [MC-Configurator].
Set up the same value as the Display's circuit number.
- 10 Write the settings to the External Device.

IMPORTANT • To write the settings, select the [Save to flash after transferring to the controller] check box.
If the data is transferred without selecting the check box, the transferred data is deleted when restarting the External Device.

◆ MPU-01 Settings

- 1 Start the ladder software.
- 2 Make a project file. Select "MPU-01" from [Model].
- 3 From the tree view, double-click [Module Configuration].
[MC-Configurator] starts.
- 4 Expand [SVC] of [MPU-01] module, and double-click [01 UNDEFINED].
- 5 Select the using Σ -V series of [Slave] dialog box, and click [OK].
- 6 Set "1" to the circuit number of [SVC].
- 7 Set "3" to the station address of the added V-series.

8 Write the settings to the MPU-01 series.

IMPORTANT

- To write the settings, select the [Save to flash after transferring to the controller] check box.
If the data is transferred without selecting the check box, the transferred data is deleted when restarting the External Device.

◆ Σ -V Series Setting

Set up communication settings with rotary switches (S1 and S2).

For details on communication settings, please refer to the manual of the External Device.

Rotary Switch	Settings	Setup Description
S1 (x16)	0	Station address
S2 (x1)	3	

◆ Notes

- Check with a network administrator about IP address. Do not set the duplicate IP address.

3.15 Setting Example 15

■ Settings of GP-Pro EX

◆ Communication Settings

To display the setup screen, from the [Project] menu, point to [System Settings] and select [Device/PLC].

◆ Device Setting

To display the [Individual Device Settings] dialog box, from [Device-Specific Settings] in the [Device/PLC] window, select the External Device and click [Settings]. To connect multiple External Devices, from [Device-Specific Settings] in the [Device/PLC] window, click [Add Device] to add another External Device.

◆ Notes

- Check with a network administrator about IP address. Do not set the duplicate IP address.
- Set IP address on the External Device address in the [Individual Device Settings] dialog box.
- You need to set IP address on the Display in the offline mode of the Display.

■ Settings of External Device

Use the ladder software (MP720 Ver.7) to set up communication settings.

For details on communication settings, please refer to the manual of the External Device.

- 1 Start the ladder software.
- 2 Make a project file. Select the main CPU models from [Model].
- 3 From the tree view, double-click [Module Configuration].
[MC-Configurator] starts.
- 4 Double-click [218IFD] on the CPU to use.
- 5 Click [Parameters] tab.
- 6 Set "IP Address" and "Subnet Mask" of "Transmission Parameters".

Setup Items	Setup Description
IP Address	192.168.0.1
Subnet Mask	255.255.255.0

- 7 Double-click the number of module which attaches a sub CPU in [MC-Configurator].
- 8 Select a sub CPU to be used in the [Module] dialog box, and click [OK].
- 9 Set "5" to the circuit number of Sub CPU that displayed in the [MC-Configurator].
Set up the same value as the Display's circuit number.
- 10 Write the settings to the External Device.

IMPORTANT

- To write the settings, select the [Save to flash after transferring to the controller] check box.
If the data is transferred without selecting the check box, the transferred data is deleted when restarting the External Device.

◆ Notes

- Check with a network administrator about IP address. Do not set the duplicate IP address.

3.16 Setting Example 16

■ Settings of GP-Pro EX

◆ Communication Settings

To display the setup screen, from the [Project] menu, point to [System Settings] and select [Device/PLC].

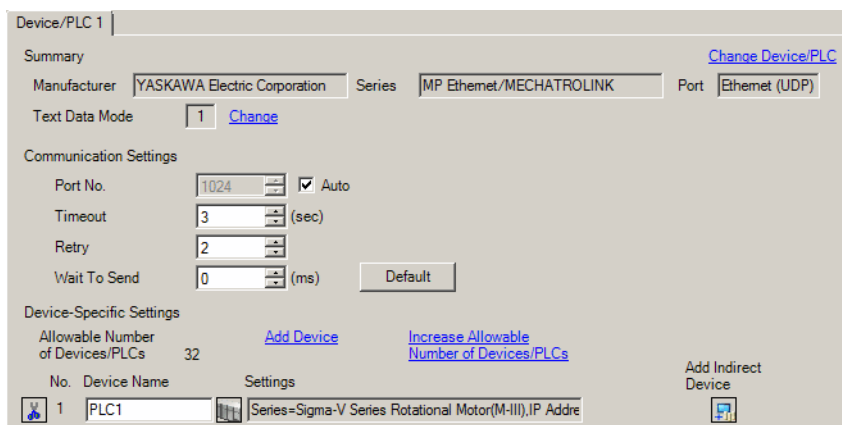

◆ Device Setting

To display the [Individual Device Settings] dialog box, from [Device-Specific Settings] in the [Device/PLC] window, select the External Device and click [Settings]. To connect multiple External Devices, from [Device-Specific Settings] in the [Device/PLC] window, click [Add Device] to add another External Device.

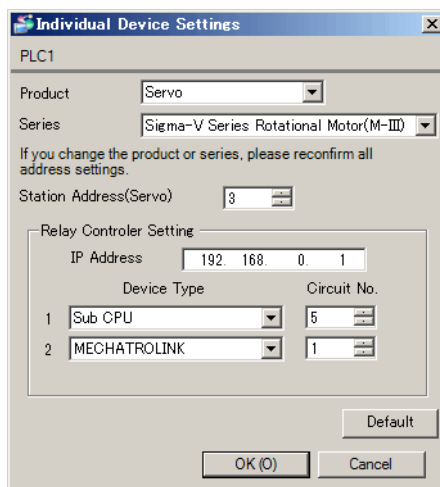

◆ Notes

- Check with a network administrator about IP address. Do not set the duplicate IP address.
- Set IP address on the External Device address in the [Individual Device Settings] dialog box.
- You need to set IP address on the Display in the offline mode of the Display.

■ Settings of External Device

Use the ladder software (MP720 Ver.7) to set up communication settings. Set the next contents.

- (1) Main CPU settings
- (2) Sub CPU settings
- (3) Σ -Vseries settings

For details on communication settings, please refer to the manual of the External Device.

◆ Main CPU Settings

- 1 Start the ladder software.
- 2 Make a project file. Select the main CPU models from [Model].
- 3 From the tree view, double-click [Module Configuration].
[MC-Configurator] starts.
- 4 Double-click [218IFD] on the CPU to use.
- 5 Click [Parameters] tab.
- 6 Set "IP Address" and "Subnet Mask" of "Transmission Parameters".

Setup Items	Setup Description
IP Address	192.168.0.1
Subnet Mask	255.255.255.0

- 7 Double-click the number of module which attaches a sub CPU in [MC-Configurator].
- 8 Select a sub CPU to be used in the [Module] dialog box, and click [OK].
- 9 Set "5" to the circuit number of Sub CPU that displayed in the [MC-Configurator].
Set up the same value as the Display's circuit number.
- 10 Write the settings to the External Device.

IMPORTANT

- To write the settings, select the [Save to flash after transferring to the controller] check box.
If the data is transferred without selecting the check box, the transferred data is deleted when restarting the External Device.

◆ Sub CPU Settings

- 1 Start the ladder software.
- 2 Make a project file. Select a Sub CPU to be used from [Model].
- 3 From the tree view, double-click [Module Configuration].
[MC-Configurator] starts.
- 4 Expand [SVC] of Sub CPU, and double-click [01 UNDEFINED].
- 5 Select the using Σ -V series of [Slave] dialog box, and click [OK].
- 6 Set "1" to the circuit number of [SVC].
- 7 Set "3" to the station address of the added V-series.

8 Write the settings to the Sub CPU.

IMPORTANT

- To write the settings, select the [Save to flash after transferring to the controller] check box.
If the data is transferred without selecting the check box, the transferred data is deleted when restarting the External Device.

◆ Σ -V Series Setting

Set up communication settings with rotary switches (S1 and S2).

For details on communication settings, please refer to the manual of the External Device.

Rotary Switch	Settings	Setup Description
S1 (x16)	0	Station address
S2 (x1)	3	

◆ Notes

- Check with a network administrator about IP address. Do not set the duplicate IP address.

3.17 Setting Example 17

■ Settings of GP-Pro EX

◆ Communication Settings

To display the setup screen, from the [Project] menu, point to [System Settings] and select [Device/PLC].

◆ Device Setting

To display the [Individual Device Settings] dialog box, from [Device-Specific Settings] in the [Device/PLC] window, select the External Device and click [Settings]. To connect multiple External Devices, from [Device-Specific Settings] in the [Device/PLC] window, click [Add Device] to add another External Device.

◆ Notes

- Check with a network administrator about IP address. Do not set the duplicate IP address.
- Set IP address on the External Device address in the [Individual Device Settings] dialog box.
- You need to set IP address on the Display in the offline mode of the Display.

■ Settings of External Device

Use the ladder software (MP720 Ver.7) to set up communication settings. Set the next contents.

- (1) Main CPU settings
- (2) Sub CPU settings
- (3) Σ -Vseries settings

For details on communication settings, please refer to the manual of the External Device.

◆ Main CPU Settings

- 1 Start the ladder software.
- 2 Make a project file. Select the main CPU models from [Model].
- 3 From the tree view, double-click [Module Configuration].
[MC-Configurator] starts.
- 4 Double-click [218IFD] on the CPU to use.
- 5 Click [Parameters] tab.
- 6 Set "IP Address" and "Subnet Mask" of "Transmission Parameters".

Setup Items	Setup Description
IP Address	192.168.0.1
Subnet Mask	255.255.255.0

- 7 Double-click the number of module which attaches a sub CPU in [MC-Configurator].
- 8 Select a sub CPU to be used in the [Module] dialog box, and click [OK].
- 9 Set "5" to the circuit number of Sub CPU that displayed in the [MC-Configurator].
Set up the same value as the Display's circuit number.
- 10 Write the settings to the External Device.

IMPORTANT

- To write the settings, select the [Save to flash after transferring to the controller] check box.
If the data is transferred without selecting the check box, the transferred data is deleted when restarting the External Device.

◆ Sub CPU Settings

- 1 Start the ladder software.
- 2 Make a project file. Select a sub CPU to be used from [Model].
- 3 From the tree view, double-click [Module Configuration].
[MC-Configurator] starts.
- 4 Expand [SVC] of Sub CPU, and double-click [01 UNDEFINED].
- 5 Select the using Σ -V series of [Slave] dialog box, and click [OK].
- 6 Set "1" to the circuit number of [SVC].
- 7 Set "3" to the station address of the added V-series.

8 Write the settings to the Sub CPU.

IMPORTANT

- To write the settings, select the [Save to flash after transferring to the controller] check box.
If the data is transferred without selecting the check box, the transferred data is deleted when restarting the External Device.

◆ Σ -V Series Setting

Set up communication settings with rotary switches (S1 and S2).

For details on communication settings, please refer to the manual of the External Device.

Rotary Switch	Settings	Setup Description
S1 (x16)	0	Station address
S2 (x1)	3	

◆ Notes

- Check with a network administrator about IP address. Do not set the duplicate IP address.

3.18 Setting Example 18

■ Settings of GP-Pro EX

◆ Communication Settings

To display the setup screen, from the [Project] menu, point to [System Settings] and select [Device/PLC].

IMPORTANT

- To connect Σ -7 Series using a 1:n connection, [Wait To Send] must be 100ms or more.

◆ Device Setting

To display the [Individual Device Settings] dialog box, from [Device-Specific Settings] in the [Device/PLC] window, select the External Device and click [Settings]. To connect multiple External Devices, from [Device-Specific Settings] in the [Device/PLC] window, click [Add Device] to add another External Device.

◆ Notes

- Check with a network administrator about IP address. Do not set the duplicate IP address.
- Set IP address on the External Device address in the [Individual Device Settings] dialog box.
- You need to set IP address on the Display in the offline mode of the Display.

■ Settings of External Device

Set communication settings for both MP and Σ -7 Series.

◆ MP Series Setting

Use the ladder software (MPE720) to set up communication settings.

For details on communication settings, please refer to the manual of the External Device.

1 Start the ladder software.

2 Make a project file.

3 From the tree view, double-click [Module Configuration].

[Engineering Manager] starts.

4 In the [Create new file] dialog box, click [OK].

5 In the [Engineering Manager]'s [Controller], use the pull-down menu to select MECHATROLINK connection module.

Select the number associated with the slot number used by the module.

When you select the MECHATROLINK connection module, its setting information is displayed in the [Engineering Manger]'s [Module details].

6 In the [module Details]'s [Circuit Number] field, enter "01".

Set up the same value as the Display's circuit number.

7 In [Details], double-click [MECHATROLINK].

8 Click the [Link Assignments] tab, and then set [ST#]'s [01] field as follows.

Setup Items	Setup Description
TYPE	Select the type of Σ -7 Series you are using.

NOTE

- [ST#] is defined based on the Σ -7 Series station address.
When the station address is 41H, define "ST#01".

9 In the [Engineering Manager]'s [Controller], select CPU.

10 In the [Module details], double-click the communication module's No. field.

11 Set [Transmission Parameters] as follows.

Setup Items	Setup Description
IP Address	192.168.0.1
Subnet Mask	255.255.255.0

12 From the [File] menu select [Save] to save your settings, and exit [Engineering Manager].

13 Write the settings to the MP Series.

IMPORTANT

- To write the settings, select the [Save to flash after transferring to the controller] check box.
If the data is transferred without selecting the check box, the transferred data is deleted when restarting the External Device.

◆ Σ -7 Series Setting

Set up communication settings with the DIP Switch (SW2) and the rotary switch (SW1). For example, when the SW2-3 is OFF and SW1 is 1, the station address is 41H.

For details on communication settings, please refer to the manual for the External Device.

- DIP Switch (SW2) Setting

DIP Switch	Settings	Setup Description
1	ON	Communication speed: 10Mbps (MECHATROLINK-II)
2	Optional	Data transfer size. ON: 32-byte data transfer OFF: 17-byte data transfer
3	OFF	Define the station address in combination with the rotary switch (SW1). ON: Tenth's position of station address is 0x5 OFF: Tenth's position of station address is 0x4
4	OFF	Always OFF

- Rotary Switch (SW1) Setting

Set the station address in combination with the DIP Switch (SW2), number 3.

Rotary Switch	Settings	Setup Description
SW1	1	Ones place of the station address

◆ Notes

- Check with a network administrator about IP address. Do not set the duplicate IP address.

3.19 Setting Example 19

■ Settings of GP-Pro EX

◆ Communication Settings

To display the setup screen, from the [Project] menu, point to [System Settings] and select [Device/PLC].

IMPORTANT

- To connect Σ -7 Series using a 1:n connection, [Wait To Send] must be 100ms or more.

◆ Device Setting

To display the [Individual Device Settings] dialog box, from [Device-Specific Settings] in the [Device/PLC] window, select the External Device and click [Settings]. To connect multiple External Devices, from [Device-Specific Settings] in the [Device/PLC] window, click [Add Device] to add another External Device.

◆ Notes

- Check with a network administrator about IP address. Do not set the duplicate IP address.
- Set IP address on the External Device address in the [Individual Device Settings] dialog box.
- You need to set IP address on the Display in the offline mode of the Display.

■ Settings of External Device

Set communication settings for both MP and Σ -7 Series.

◆ MP Series Setting

Use the ladder software (MPE720) to set up communication settings.

For details on communication settings, please refer to the manual of the External Device.

- 1 Start the ladder software.
- 2 Make a project file.
- 3 From the tree view, double-click [Module Configuration].
[Engineering Manager] starts.
- 4 In the [Create new file] dialog box, click [OK].
- 5 In the [Engineering Manager]'s [Controller], use the pull-down menu to select MECHATROLINK connection module.
Select the number associated with the slot number used by the module.
When you select the MECHATROLINK connection module, its setting information is displayed in the [Engineering Manger]'s [Module details].
- 6 In the [module Details]'s [Circuit Number] field, enter "01".
Set up the same value as the Display's circuit number.
- 7 In [Details], double-click [MECHATROLINK].
- 8 Click the [Link Assignments] tab, and then [ST#]'s [01] as follows.

Setup Items	Setup Description
ADR	03H
ExADR	00
VENDOR	Yaskawa Electric co.
DEVICE	Σ -7 Series type

NOTE

- [PROFILE], [BYTE] and [SCAN] are defined automatically.

- 9 In the [Engineering Manager]'s [Controller], select CPU.
- 10 In the [Module details], double-click the communication module's No. field.
- 11 Set [Transmission Parameters] as follows.

Setup Items	Setup Description
IP Address	192.168.0.1
Subnet Mask	255.255.255.0

- 12 From the [File] menu select [Save] to save your settings, and exit [Engineering Manager].
- 13 Write the settings to MP Series.

IMPORTANT

- To write the settings, select the [Save to flash after transferring to the controller] check box.
If the data is transferred without selecting the check box, the transferred data is deleted when restarting the External Device.

◆ Σ-7 Series Setting

Set up communication settings with rotary switches (S1 and S2).

For details on communication settings, please refer to the manual of the External Device.

Rotary Switch	Settings	Setup Description
S1 (x16)	0	Station address
S2 (x1)	3	

◆ Notes

- Check with a network administrator about IP address. Do not set the duplicate IP address.

3.20 Setting Example 20

■ Settings of GP-Pro EX

◆ Communication Settings

To display the setup screen, from the [Project] menu, point to [System Settings] and select [Device/PLC].

◆ Device Setting

To display the [Individual Device Settings] dialog box, from [Device-Specific Settings] in the [Device/PLC] window, select the External Device and click [Settings]. To connect multiple External Devices, from [Device-Specific Settings] in the [Device/PLC] window, click [Add Device] to add another External Device.

◆ Notes

- Check with a network administrator about IP address. Do not set the duplicate IP address.
- Set IP address on the External Device address in the [Individual Device Settings] dialog box.
- You need to set IP address on the Display in the offline mode of the Display.

■ Settings of External Device

Use the ladder software (MP720 Ver.7) to set up communication settings. Set the next contents.

- (1) Main CPU settings
- (2) MPU-01 settings
- (3) Σ -7 series settings

For details on communication settings, please refer to the manual of the External Device.

◆ Main CPU Settings

- 1 Start the ladder software.
- 2 Make a project file. Select the main CPU models from [Model].
- 3 From the tree view, double-click [Module Configuration].
[MC-Configurator] starts.
- 4 Double-click [218IFD] on the CPU to use.
- 5 Click [Parameters] tab.
- 6 Set "IP Address" and "Subnet Mask" of "Transmission Parameters".

Setup Items	Setup Description
IP Address	192.168.0.1
Subnet Mask	255.255.255.0

- 7 Double-click the module number corresponding to the option slot which attaches MPU-01 in the [MC-Configurator]
- 8 Select [MPU-01] in the [Module] dialog box, and click [OK].
- 9 Set "3" to the circuit number of MPU-01 that displayed in the [MC-Configurator].
Set up the same value as the Display's circuit number.
- 10 Write the settings to the External Device.

IMPORTANT • To write the settings, select the [Save to flash after transferring to the controller] check box.
If the data is transferred without selecting the check box, the transferred data is deleted when restarting the External Device.

◆ MPU-01 Settings

- 1 Start the ladder software.
- 2 Make a project file. Select "MPU-01" from [Model].
- 3 From the tree view, double-click [Module Configuration].
[MC-Configurator] starts.
- 4 Expand [SVC] of [MPU-01] module, and double-click [01 UNDEFINED].
- 5 Select the using Σ -7 series of [Slave] dialog box, and click [OK].
- 6 Set "1" to the circuit number of [SVC].
- 7 Set "3" to the station address of the added Σ -7 series.

8 Write the settings to the MPU-01 series.

IMPORTANT

- To write the settings, select the [Save to flash after transferring to the controller] check box.
If the data is transferred without selecting the check box, the transferred data is deleted when restarting the External Device.

◆ Σ -7 Series Setting

Set up communication settings with rotary switches (S1 and S2).

For details on communication settings, please refer to the manual of the External Device.

Rotary Switch	Settings	Setup Description
S1 (x16)	0	Station address
S2 (x1)	3	

◆ Notes

- Check with a network administrator about IP address. Do not set the duplicate IP address.

3.21 Setting Example 21

■ Settings of GP-Pro EX

◆ Communication Settings

To display the setup screen, from the [Project] menu, point to [System Settings] and select [Device/PLC].

◆ Device Setting

To display the [Individual Device Settings] dialog box, from [Device-Specific Settings] in the [Device/PLC] window, select the External Device and click [Settings]. To connect multiple External Devices, from [Device-Specific Settings] in the [Device/PLC] window, click [Add Device] to add another External Device.

◆ Notes

- Check with a network administrator about IP address. Do not set the duplicate IP address.
- Set IP address on the External Device address in the [Individual Device Settings] dialog box.
- You need to set IP address on the Display in the offline mode of the Display.

■ Settings of External Device

Use the ladder software (MP720 Ver.7) to set up communication settings. Set the next contents.

(1) Main CPU settings

(2) Sub CPU settings

(3) Σ -7 series settings

For details on communication settings, please refer to the manual of the External Device.

◆ Main CPU Settings

- 1 Start the ladder software.
- 2 Make a project file. Select the main CPU models from [Model].
- 3 From the tree view, double-click [Module Configuration].
[MC-Configurator] starts.
- 4 Double-click [218IFD] on the CPU to use.
- 5 Click [Parameters] tab.
- 6 Set "IP Address" and "Subnet Mask" of "Transmission Parameters".

Setup Items	Setup Description
IP Address	192.168.0.1
Subnet Mask	255.255.255.0

- 7 Double-click the number of module which attaches a sub CPU in [MC-Configurator].
- 8 Select a sub CPU to be used in the [Module] dialog box, and click [OK].
- 9 Set "5" to the circuit number of Sub CPU that displayed in the [MC-Configurator].
Set up the same value as the Display's circuit number.
- 10 Write the settings to the External Device.

IMPORTANT

- To write the settings, select the [Save to flash after transferring to the controller] check box.
If the data is transferred without selecting the check box, the transferred data is deleted when restarting the External Device.

◆ Sub CPU Settings

- 1 Start the ladder software.
- 2 Make a project file. Select a Sub CPU to be used from [Model].
- 3 From the tree view, double-click [Module Configuration].
[MC-Configurator] starts.
- 4 Expand [SVC] of Sub CPU, and double-click [01 UNDEFINED].
- 5 Select the using Σ -7 series of [Slave] dialog box, and click [OK].
- 6 Set "1" to the circuit number of [SVC].
- 7 Set "3" to the station address of the added Σ -7 series.

8 Write the settings to the Sub CPU.

IMPORTANT

- To write the settings, select the [Save to flash after transferring to the controller] check box.
If the data is transferred without selecting the check box, the transferred data is deleted when restarting the External Device.

◆ Σ -7 Series Setting

Set up communication settings with rotary switches (S1 and S2).

For details on communication settings, please refer to the manual of the External Device.

Rotary Switch	Settings	Setup Description
S1 (x16)	0	Station address
S2 (x1)	3	

◆ Notes

- Check with a network administrator about IP address. Do not set the duplicate IP address.

3.22 Setting Example 22

■ Settings of GP-Pro EX

◆ Communication Settings

To display the setup screen, from the [Project] menu, point to [System Settings] and select [Device/PLC].

IMPORTANT

- To connect Σ -7 Series using a 1:n connection, [Wait To Send] must be 100ms or more.

◆ Device Setting

To display the [Individual Device Settings] dialog box, from [Device-Specific Settings] in the [Device/PLC] window, select the External Device and click [Settings]. To connect multiple External Devices, from [Device-Specific Settings] in the [Device/PLC] window, click [Add Device] to add another External Device.

◆ Notes

- Check with a network administrator about IP address. Do not set the duplicate IP address.
- Set IP address on the External Device address in the [Individual Device Settings] dialog box.
- You need to set IP address on the Display in the offline mode of the Display.

■ Settings of External Device

Set communication settings for both MP and Σ -7 Series.

◆ MP Series Setting

Use the ladder software (MPE720) to set up communication settings.

For details on communication settings, please refer to the manual of the External Device.

1 Start the ladder software.

2 Make a project file.

3 From the tree view, double-click [Module Configuration].

[Engineering Manager] starts.

4 In the [Create new file] dialog box, click [OK].

5 In the [Engineering Manager]'s [Controller], use the pull-down menu to select MECHATROLINK connection module.

Select the number associated with the slot number used by the module.

When you select the MECHATROLINK connection module, its setting information is displayed in the [Engineering Manger]'s [Module details].

6 In the [module Details]'s [Circuit Number] field, enter "01".

Set up the same value as the Display's circuit number.

7 In [Details], double-click [MECHATROLINK].

8 Click the [Link Assignments] tab, and then [ST#]'s [01] as follows.

Setup Items	Setup Description
ADR	03H
ExADR	00
VENDOR	Yaskawa Electric co.
DEVICE	Σ -7 Series type

NOTE

- [PROFILE], [BYTE] and [SCAN] are defined automatically.

9 In the [Engineering Manager]'s [Controller], select CPU.

10 In the [Module details], double-click the communication module's No. field.

11 Set [Transmission Parameters] as follows.

Setup Items	Setup Description
IP Address	192.168.0.1
Subnet Mask	255.255.255.0

12 From the [File] menu select [Save] to save your settings, and exit [Engineering Manager].

13 Write the settings to MP Series.

IMPORTANT

- To write the settings, select the [Save to flash after transferring to the controller] check box.
If the data is transferred without selecting the check box, the transferred data is deleted when restarting the External Device.

◆ Σ-7 Series Setting

Set up communication settings with rotary switches (S1 and S2).

For details on communication settings, please refer to the manual of the External Device.

Rotary Switch	Settings	Setup Description
S1 (x16)	0	Station address
S2 (x1)	3	

◆ Notes

- Check with a network administrator about IP address. Do not set the duplicate IP address.

3.23 Setting Example 23

■ Settings of GP-Pro EX

◆ Communication Settings

To display the setup screen, from the [Project] menu, point to [System Settings] and select [Device/PLC].

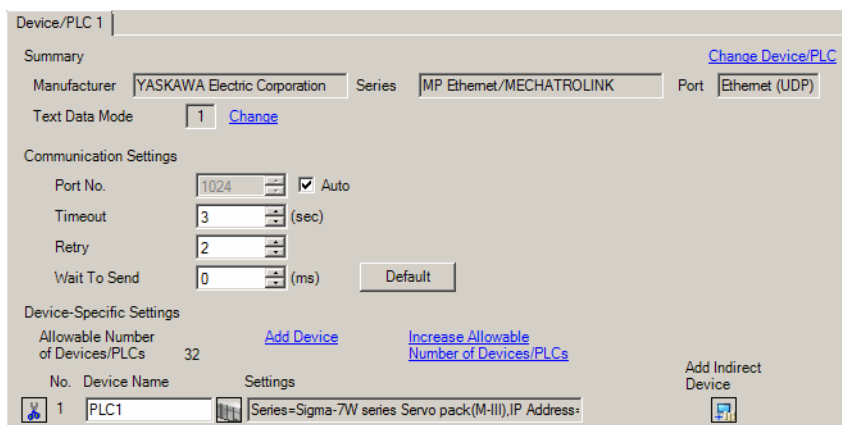

◆ Device Setting

To display the [Individual Device Settings] dialog box, from [Device-Specific Settings] in the [Device/PLC] window, select the External Device and click [Settings]. To connect multiple External Devices, from [Device-Specific Settings] in the [Device/PLC] window, click [Add Device] to add another External Device.

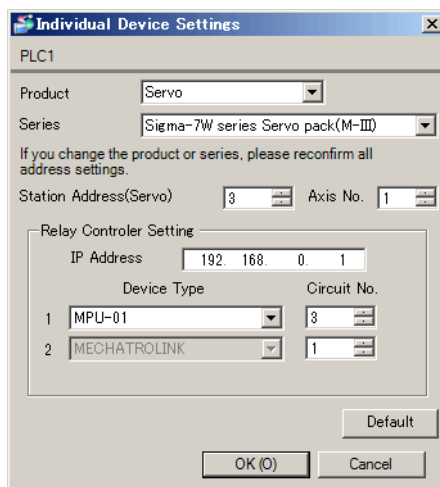

◆ Notes

- Check with a network administrator about IP address. Do not set the duplicate IP address.
- Set IP address on the External Device address in the [Individual Device Settings] dialog box.
- You need to set IP address on the Display in the offline mode of the Display.

■ Settings of External Device

Use the ladder software (MP720 Ver.7) to set up communication settings. Set the next contents.

- (1) Main CPU settings
- (2) MPU-01 settings
- (3) Σ -7 series settings

For details on communication settings, please refer to the manual of the External Device.

◆ Main CPU Settings

- 1 Start the ladder software.
- 2 Make a project file. Select the main CPU models from [Model].
- 3 From the tree view, double-click [Module Configuration].
[MC-Configurator] starts.
- 4 Double-click [218IFD] on the CPU to use.
- 5 Click [Parameters] tab.
- 6 Set "IP Address" and "Subnet Mask" of "Transmission Parameters".

Setup Items	Setup Description
IP Address	192.168.0.1
Subnet Mask	255.255.255.0

- 7 Double-click the module number corresponding to the option slot which attaches MPU-01 in the [MC-Configurator]
- 8 Select [MPU-01] in the [Module] dialog box, and click [OK].
- 9 Set "3" to the circuit number of MPU-01 that displayed in the [MC-Configurator].
Set up the same value as the Display's circuit number.
- 10 Write the settings to the External Device.

IMPORTANT • To write the settings, select the [Save to flash after transferring to the controller] check box.
If the data is transferred without selecting the check box, the transferred data is deleted when restarting the External Device.

◆ MPU-01 Settings

- 1 Start the ladder software.
- 2 Make a project file. Select "MPU-01" from [Model].
- 3 From the tree view, double-click [Module Configuration].
[MC-Configurator] starts.
- 4 Expand [SVC] of [MPU-01] module, and double-click [01 UNDEFINED].
- 5 Select the using Σ -7 series of [Slave] dialog box, and click [OK].
- 6 Set "1" to the circuit number of [SVC].
- 7 Set "3" to the station address of the added Σ -7 series.

8 Write the settings to the MPU-01 series.

IMPORTANT

- To write the settings, select the [Save to flash after transferring to the controller] check box.
If the data is transferred without selecting the check box, the transferred data is deleted when restarting the External Device.

◆ Σ -7 Series Setting

Set up communication settings with rotary switches (S1 and S2).

For details on communication settings, please refer to the manual of the External Device.

Rotary Switch	Settings	Setup Description
S1 (x16)	0	Station address
S2 (x1)	3	

◆ Notes

- Check with a network administrator about IP address. Do not set the duplicate IP address.

3.24 Setting Example 24

■ Settings of GP-Pro EX

◆ Communication Settings

To display the setup screen, from the [Project] menu, point to [System Settings] and select [Device/PLC].

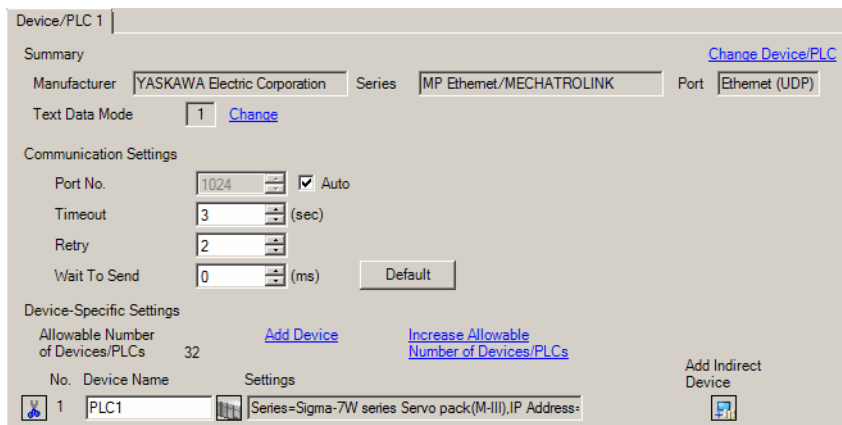

◆ Device Setting

To display the [Individual Device Settings] dialog box, from [Device-Specific Settings] in the [Device/PLC] window, select the External Device and click [Settings]. To connect multiple External Devices, from [Device-Specific Settings] in the [Device/PLC] window, click [Add Device] to add another External Device.

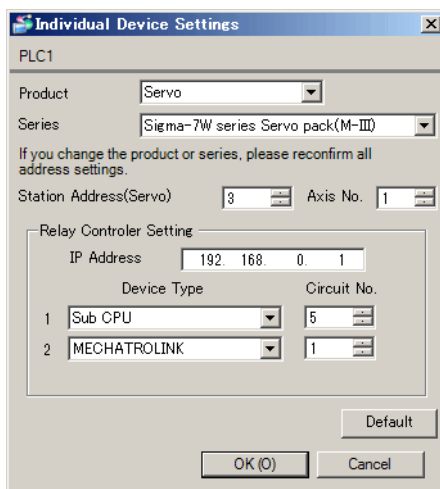

◆ Notes

- Check with a network administrator about IP address. Do not set the duplicate IP address.
- Set IP address on the External Device address in the [Individual Device Settings] dialog box.
- You need to set IP address on the Display in the offline mode of the Display.

■ Settings of External Device

Use the ladder software (MP720 Ver.7) to set up communication settings. Set the next contents.

(1) Main CPU settings

(2) Sub CPU settings

(3) Σ -7 series settings

For details on communication settings, please refer to the manual of the External Device.

◆ Main CPU Settings

- 1 Start the ladder software.
- 2 Make a project file. Select the main CPU models from [Model].
- 3 From the tree view, double-click [Module Configuration].
[MC-Configurator] starts.
- 4 Double-click [218IFD] on the CPU to use.
- 5 Click [Parameters] tab.
- 6 Set "IP Address" and "Subnet Mask" of "Transmission Parameters".

Setup Items	Setup Description
IP Address	192.168.0.1
Subnet Mask	255.255.255.0

- 7 Double-click the number of module which attaches a sub CPU in [MC-Configurator].
- 8 Select a sub CPU to be used in the [Module] dialog box, and click [OK].
- 9 Set "5" to the circuit number of Sub CPU that displayed in the [MC-Configurator].
Set up the same value as the Display's circuit number.
- 10 Write the settings to the External Device.

IMPORTANT

- To write the settings, select the [Save to flash after transferring to the controller] check box.
If the data is transferred without selecting the check box, the transferred data is deleted when restarting the External Device.

◆ Sub CPU Settings

- 1 Start the ladder software.
- 2 Make a project file. Select a Sub CPU to be used from [Model].
- 3 From the tree view, double-click [Module Configuration].
[MC-Configurator] starts.
- 4 Expand [SVC] of Sub CPU, and double-click [01 UNDEFINED].
- 5 Select the using Σ -7 series of [Slave] dialog box, and click [OK].
- 6 Set "1" to the circuit number of [SVC].
- 7 Set "3" to the station address of the added Σ -7 series.

8 Write the settings to the Sub CPU.

IMPORTANT

- To write the settings, select the [Save to flash after transferring to the controller] check box.
If the data is transferred without selecting the check box, the transferred data is deleted when restarting the External Device.

◆ Σ -7 Series Setting

Set up communication settings with rotary switches (S1 and S2).

For details on communication settings, please refer to the manual of the External Device.

Rotary Switch	Settings	Setup Description
S1 (x16)	0	Station address
S2 (x1)	3	

◆ Notes

- Check with a network administrator about IP address. Do not set the duplicate IP address.

3.25 Setting Example 25

■ Settings of GP-Pro EX

◆ Communication Settings

To display the setup screen, from the [Project] menu, point to [System Settings] and select [Device/PLC].

IMPORTANT

- To connect Remote I/O Series using a 1:n connection, [Wait To Send] must be 100ms or more.

◆ Device Setting

To display the [Individual Device Settings] dialog box, from [Device-Specific Settings] in the [Device/PLC] window, select the External Device and click [Settings]. To connect multiple External Devices, from [Device-Specific Settings] in the [Device/PLC] window, click [Add Device] to add another External Device.

◆ Notes

- Check with a network administrator about IP address. Do not set the duplicate IP address.
- Set IP address on the External Device address in the [Individual Device Settings] dialog box.
- You need to set IP address on the Display in the offline mode of the Display.

■ Settings of External Device

Use the ladder software (MP720 Ver.7) to set up communication settings. Set the next contents.

(1) Main CPU settings

(2) Remote I/O settings

For details on communication settings, please refer to the manual of the External Device.

◆ Main CPU Settings

1 Start the ladder software.

2 Make a project file. From the [Model] list, select the main CPU.

3 From the [Start] tab, click [Module Configuration].

[MC-Configurator] starts up.

4 On the CPU you want to use, double-click [218IFD].

5 Click the [Parameters] tab.

6 In the [Transmission Parameters] group define the [IP Address] and [Subnet Mask] as follows.

Setup Items	Setup Description
IP Address	192.168.0.1
Subnet Mask	255.255.255.0

7 On the CPU you want to use, set the [SVC32] circuit number to "1".

Set up the same value as the Display's circuit number.

8 On the CPU you want to use, open [SVC32], and double-click [01 UNDEFINED].

9 In the tree view, from [I/O]-[Other], select [WILDCARD I/O], and click [OK].

10 For the [WILDCARD I/O] station number, set "3".

11 Write the settings to the External Device.

IMPORTANT

- To write the settings, select the [Save to flash after transferring to the controller] check box.

If the data is transferred without selecting the check box, the transferred data is deleted when restarting the External Device.

◆ Remote I/O Settings

Set up communication settings with rotary switches (S1 and S2).

For details on communication settings, please refer to the manual of the External Device.

Rotary Switch	Settings	Setup Description
S1 (x16)	0	Station address
S2 (x1)	3	

◆ Notes

- Check with a network administrator about IP address. Do not set the duplicate IP address.

3.26 Setting Example 26

■ Settings of GP-Pro EX

◆ Communication Settings

To display the setup screen, from the [Project] menu, point to [System Settings] and select [Device/PLC].

Device/PLC 1

Summary [Change Device/PLC](#)

Manufacturer: YASKAWA Electric Corporation Series: MP Ethernet/MECHATROLINK Port: Ethernet (UDP)

Text Data Mode: 1 [Change](#)

Communication Settings

Port No.: 1024 Auto

Timeout: 3 (sec)

Retry: 2

Wait To Send: 0 (ms) [Default](#)

Device-Specific Settings

Allowable Number of Devices/PLCs: 32 [Add Device](#) [Increase Allowable Number of Devices/PLCs](#)

No.	Device Name	Settings	Add Indirect Device
1	PLC1	Series=R7G4HML3-LC2(M-III),IP Address=192.168.00	

◆ Device Setting

To display the [Individual Device Settings] dialog box, from [Device-Specific Settings] in the [Device/PLC] window, select the External Device and click [Settings] . To connect multiple External Devices, from [Device-Specific Settings] in the [Device/PLC] window, click [Add Device] to add another External Device.

Individual Device Settings

PLC1

Product: I/O(M-System)

Series: R7G4HML3-LC2(M-III)

If you change the product or series, please reconfirm all address settings.

Station Address(I/O): 3

Relay Controller Setting

IP Address: 192.168.0.1

	Device Type	Circuit No.
1	MPU-01	3
2	MECHATROLINK	1

[Default](#)

[OK \(O\)](#) [Cancel](#)

◆ Notes

- Check with a network administrator about IP address. Do not set the duplicate IP address.
- Set IP address on the External Device address in the [Individual Device Settings] dialog box.
- You need to set IP address on the Display in the offline mode of the Display.

■ Settings of External Device

Use the ladder software (MP720 Ver.7) to set up communication settings. Set the next contents.

(1) Main CPU settings

(2) MPU-01 settings

(3) Remote I/O settings

For details on communication settings, please refer to the manual of the External Device.

◆ Main CPU Settings

- 1 Start the ladder software.
- 2 Make a project file. From the [Model] list, select the main CPU.
- 3 From the [Start] tab, click [Module Configuration].
[MC-Configurator] starts up.
- 4 On the CPU you want to use, double-click [218IFD].
- 5 Click the [Parameters] tab.
- 6 In the [Transmission Parameters] group define the [IP Address] and [Subnet Mask] as follows.

Setup Items	Setup Description
IP Address	192.168.0.1
Subnet Mask	255.255.255.0

- 7 Double-click the module number associated with the option slot attached to MPU-01 in the [MC-Configurator].
- 8 In the [Module] dialog box, select [MPU-01] and click [OK].
- 9 In the [MC-Configurator], set [MPU-01]'s circuit number to "3".
Set up the same value as the Display's circuit number.
- 10 Write the settings to the External Device.

IMPORTANT

- To write the settings, select the [Save to flash after transferring to the controller] check box.
If the data is transferred without selecting the check box, the transferred data is deleted when restarting the External Device.

◆ MPU-01 Settings

- 1 Start the ladder software.
- 2 Make a project file. Select "MPU-01" from [Model].
- 3 From the tree view, click [Module Configuration].
[MC-Configurator] starts.
- 4 Expand [SVC] of [MPU-01] module, and double-click [01 UNDEFINED].
- 5 Select the using Remote I/O of [Slave] dialog box, and click [OK].
- 6 Set "1" to the circuit number of [SVC].
- 7 Set "3" to the station address of the added Remote I/O.

8 Write the settings to the MPU-01 series.

IMPORTANT

- To write the settings, select the [Save to flash after transferring to the controller] check box.
If the data is transferred without selecting the check box, the transferred data is deleted when restarting the External Device.

◆ Remote I/O Settings

Set up communication settings with rotary switches (S1 and S2).

For details on communication settings, please refer to the manual of the External Device.

Rotary Switch	Settings	Setup Description
S1 (x16)	0	Station address
S2 (x1)	3	

◆ Notes

- Check with a network administrator about IP address. Do not set the duplicate IP address.

3.27 Setting Example 27

■ Settings of GP-Pro EX

◆ Communication Settings

To display the setup screen, from the [Project] menu, point to [System Settings] and select [Device/PLC].

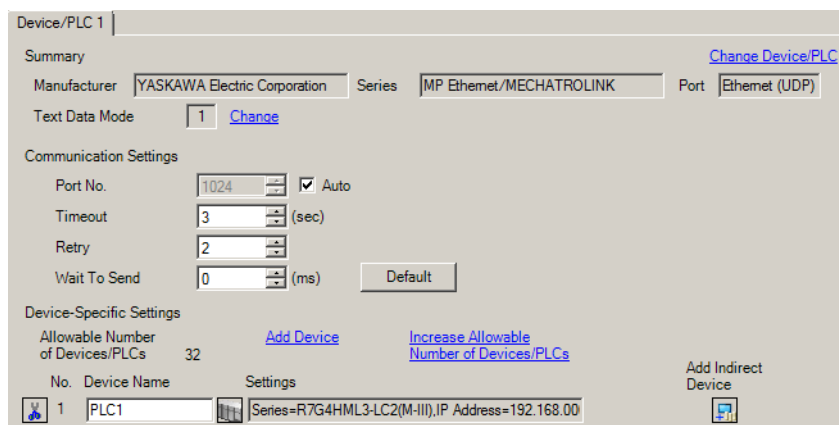

◆ Device Setting

To display the [Individual Device Settings] dialog box, from [Device-Specific Settings] in the [Device/PLC] window, select the External Device and click [Settings]. To connect multiple External Devices, from [Device-Specific Settings] in the [Device/PLC] window, click [Add Device] to add another External Device.

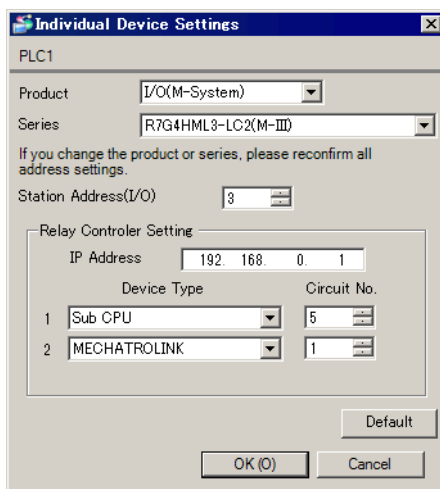

◆ Notes

- Check with a network administrator about IP address. Do not set the duplicate IP address.
- Set IP address on the External Device address in the [Individual Device Settings] dialog box.
- You need to set IP address on the Display in the offline mode of the Display.

■ Settings of External Device

Use the ladder software (MP720 Ver.7) to set up communication settings. Set the next contents.

- (1) Main CPU settings
- (2) MPU-01 settings
- (3) Remote I/O settings

For details on communication settings, please refer to the manual of the External Device.

◆ Main CPU Settings

- 1 Start the ladder software.
- 2 Make a project file. From the [Model] list, select the main CPU.
- 3 From the [Start] tab, click [Module Configuration].
[MC-Configurator] starts up.
- 4 On the CPU you want to use, double-click [218IFD].
- 5 Click the [Parameters] tab.
- 6 In the [Transmission Parameters] group define the [IP Address] and [Subnet Mask] as follows.

Setup Items	Setup Description
IP Address	192.168.0.1
Subnet Mask	255.255.255.0

- 7 Double-click the module number attached to the sub CPU in the [MC-Configurator].
- 8 In the [Module] dialog box, select the sub CPU in use and click [OK].
- 9 In the [MC-Configurator], set the sub CPU circuit number to "5".
Set up the same value as the Display's circuit number.
- 10 Write the settings to the External Device.

IMPORTANT • To write the settings, select the [Save to flash after transferring to the controller] check box.
If the data is transferred without selecting the check box, the transferred data is deleted when restarting the External Device.

◆ Sub CPU Settings

- 1 Start the ladder software.
- 2 Make a project file. Select a Sub CPU to be used from [Model].
- 3 From the tree view, click [Module Configuration].
[MC-Configurator] starts.
- 4 Expand [SVC] of Sub CPU, and double-click [01 UNDEFINED].
- 5 Select the using Remote I/O of [Slave] dialog box, and click [OK].
- 6 Set "1" to the circuit number of [SVC].
- 7 Set "3" to the station address of the added Remote I/O.

8 Write the settings to the Sub CPU.

IMPORTANT

- To write the settings, select the [Save to flash after transferring to the controller] check box.
If the data is transferred without selecting the check box, the transferred data is deleted when restarting the External Device.

◆ Remote I/O Settings

Set up communication settings with rotary switches (S1 and S2).

For details on communication settings, please refer to the manual of the External Device.

Rotary Switch	Settings	Setup Description
S1 (x16)	0	Station address
S2 (x1)	3	

◆ Notes

- Check with a network administrator about IP address. Do not set the duplicate IP address.

3.28 Setting Example 28

■ Settings of GP-Pro EX

◆ Communication Settings

To display the setup screen, from the [Project] menu, point to [System Settings] and select [Device/PLC].

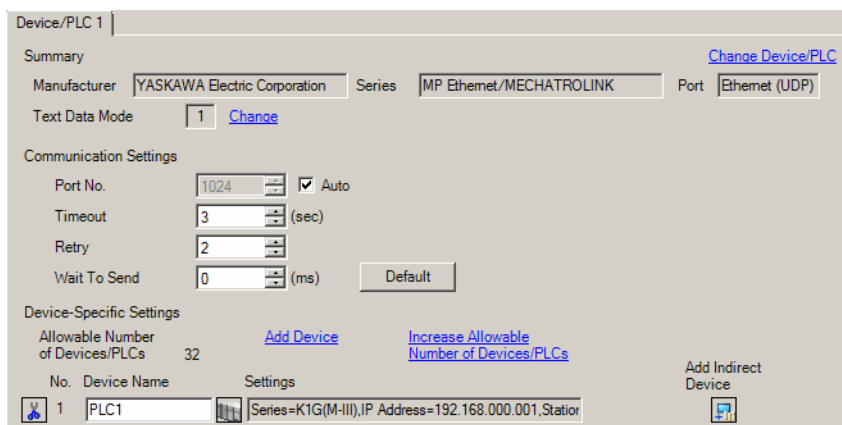

IMPORTANT

- To connect Remote I/O Series using a 1:n connection, [Wait To Send] must be 100ms or more.

◆ Device Setting

To display the [Individual Device Settings] dialog box, from [Device-Specific Settings] in the [Device/PLC] window, select the External Device and click [Settings]. To connect multiple External Devices, from [Device-Specific Settings] in the [Device/PLC] window, click [Add Device] to add another External Device.

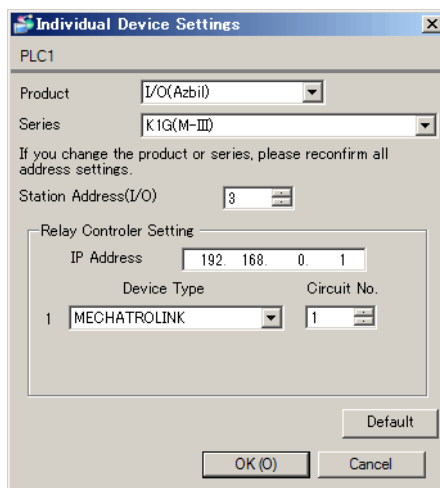

◆ Notes

- Check with a network administrator about IP address. Do not set the duplicate IP address.
- Set IP address on the External Device address in the [Individual Device Settings] dialog box.
- You need to set IP address on the Display in the offline mode of the Display.

■ Settings of External Device

Use the ladder software (MP720 Ver.7) to set up communication settings. Set the next contents.

(1) Main CPU settings

(2) Controller settings

For details on communication settings, please refer to the manual of the External Device.

◆ Main CPU Settings

- 1 Start the ladder software.
- 2 Make a project file. From the [Model] list, select the main CPU.
- 3 From the [Start] tab, click [Module Configuration].
[MC-Configurator] starts up.
- 4 On the CPU you want to use, double-click [218IFD].
- 5 Click the [Parameters] tab.
- 6 In the [Transmission Parameters] group define the [IP Address] and [Subnet Mask] as follows.

Setup Items	Setup Description
IP Address	192.168.0.1
Subnet Mask	255.255.255.0

- 7 On the CPU you want to use, set the [SVC32] circuit number to "1".
Set up the same value as the Display's circuit number.
- 8 On the CPU you want to use, open [SVC32], and double-click [01 UNDEFINED].
- 9 In the tree view, from [I/O]-[Other], select [WILDCARD I/O], and click [OK].
- 10 For the [WILDCARD I/O] station number, set "3".
- 11 Write the settings to the External Device.

IMPORTANT • To write the settings, select the [Save to flash after transferring to the controller] check box.
If the data is transferred without selecting the check box, the transferred data is deleted when restarting the External Device.

◆ Controller Settings

To configure communication settings for the External Device, use the CPU unit's Run, para, enter and cursor keys. Refer to your External Device manual for details.

Procedure

- 1 When [Run] is lit, press and hold the Run key for 3 seconds.
- 2 Press the para key to display parameters.
- 3 Use the up/down cursor keys to display the setup items. (Setup items will blink.)
- 4 Press the enter key to select a setup item.
- 5 Select the settings with the cursor keys. (Settings will blink.)
- 6 Press the enter key to confirm the settings.
- 7 Press the Run key, and [Run] is lit.

Settings

Setup Items	Settings	Setup Description
A09	3	MECHATROLINK-III station address

◆ Notes

- Check with a network administrator about IP address. Do not set the duplicate IP address.

3.29 Setting Example 29

■ Settings of GP-Pro EX

◆ Communication Settings

To display the setup screen, from the [Project] menu, point to [System Settings] and select [Device/PLC].

Device/PLC 1

Summary [Change Device/PLC](#)

Manufacturer Series Port

Text Data Mode [Change](#)

Communication Settings

Port No. Auto

Timeout (sec)

Retry

Wait To Send (ms)

Device-Specific Settings

Allowable Number of Devices/PLCs 32 [Add Device](#) [Increase Allowable Number of Devices/PLCs](#)

No.	Device Name	Settings	Add Indirect Device
1	PLC1	Series=K1G(M-III),IP Address=192.168.0.001.Station	<input type="button" value="Add"/>

◆ Device Setting

To display the [Individual Device Settings] dialog box, from [Device-Specific Settings] in the [Device/PLC] window, select the External Device and click [Settings]. To connect multiple External Devices, from [Device-Specific Settings] in the [Device/PLC] window, click [Add Device] to add another External Device.

Individual Device Settings

PLC1

Product

Series

If you change the product or series, please reconfirm all address settings.

Station Address(I/O)

Relay Controller Setting

IP Address

	Device Type	Circuit No.
1	<input type="text" value="MPU-01"/>	<input type="text" value="3"/>
2	<input type="text" value="MECHATROLINK"/>	<input type="text" value="1"/>

◆ Notes

- Check with a network administrator about IP address. Do not set the duplicate IP address.
- Set IP address on the External Device address in the [Individual Device Settings] dialog box.
- You need to set IP address on the Display in the offline mode of the Display.

■ Settings of External Device

Use the ladder software (MP720 Ver.7) to set up communication settings. Set the next contents.

- (1) Main CPU settings
- (2) MPU-01 settings
- (3) Controller settings

For details on communication settings, please refer to the manual of the External Device.

◆ Main CPU Settings

- 1 Start the ladder software.
- 2 Make a project file. From the [Model] list, select the main CPU.
- 3 From the [Start] tab, click [Module Configuration].
[MC-Configurator] starts up.
- 4 On the CPU you want to use, double-click [218IFD].
- 5 Click the [Parameters] tab.
- 6 In the [Transmission Parameters] group define the [IP Address] and [Subnet Mask] as follows.

Setup Items	Setup Description
IP Address	192.168.0.1
Subnet Mask	255.255.255.0

- 7 Double-click the module number associated with the option slot attached to MPU-01 in the [MC-Configurator].
- 8 In the [Module] dialog box, select [MPU-01] and click [OK].
- 9 In the [MC-Configurator], set [MPU-01]'s circuit number to "3".
Set up the same value as the Display's circuit number.
- 10 Write the settings to the External Device.

IMPORTANT

- To write the settings, select the [Save to flash after transferring to the controller] check box.
If the data is transferred without selecting the check box, the transferred data is deleted when restarting the External Device.

◆ MPU-01 Settings

- 1 Start the ladder software.
- 2 Make a project file. Select "MPU-01" from [Model].
- 3 From the tree view, click [Module Configuration].
[MC-Configurator] starts.
- 4 Expand [SVC] of [MPU-01] module, and double-click [01 UNDEFINED].
- 5 Select the using Controller of [Slave] dialog box, and click [OK].
- 6 Set "1" to the circuit number of [SVC].
- 7 Set "3" to the station address of the added Controller.

8 Write the settings to the MPU-01 series.

IMPORTANT

- To write the settings, select the [Save to flash after transferring to the controller] check box.
If the data is transferred without selecting the check box, the transferred data is deleted when restarting the External Device.

◆ Controller Settings

To configure communication settings for the External Device, use the CPU unit's Run, para, enter and cursor keys. Refer to your External Device manual for details.

Procedure

- 1 When [Run] is lit, press and hold the Run key for 3 seconds.
- 2 Press the para key to display parameters.
- 3 Use the up/down cursor keys to display the setup items. (Setup items will blink.)
- 4 Press the enter key to select a setup item.
- 5 Select the settings with the cursor keys. (Settings will blink.)
- 6 Press the enter key to confirm the settings.
- 7 Press the Run key, and [Run] is lit.

Settings

Setup Items	Settings	Setup Description
A09	3	MECHATROLINK-III station address

◆ Notes

- Check with a network administrator about IP address. Do not set the duplicate IP address.

3.30 Setting Example 30

■ Settings of GP-Pro EX

◆ Communication Settings

To display the setup screen, from the [Project] menu, point to [System Settings] and select [Device/PLC].

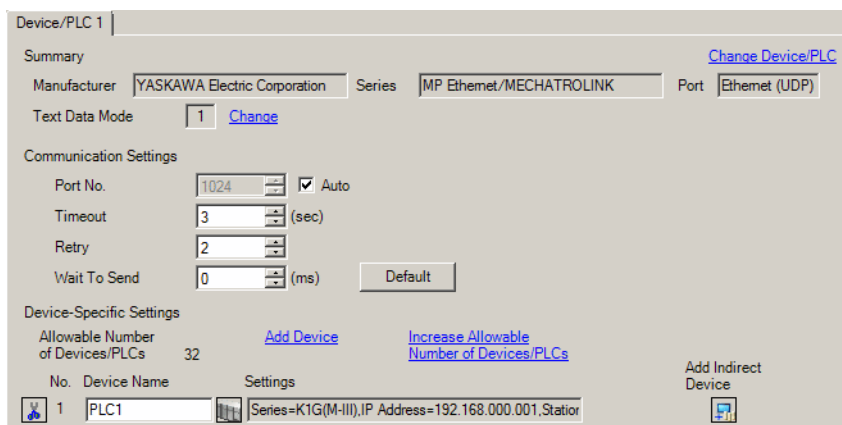

◆ Device Setting

To display the [Individual Device Settings] dialog box, from [Device-Specific Settings] in the [Device/PLC] window, select the External Device and click [Settings]. To connect multiple External Devices, from [Device-Specific Settings] in the [Device/PLC] window, click [Add Device] to add another External Device.

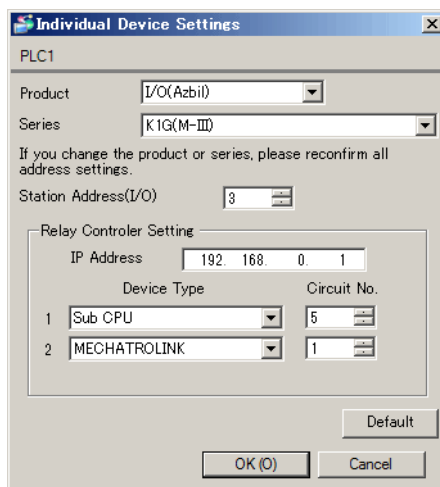

◆ Notes

- Check with a network administrator about IP address. Do not set the duplicate IP address.
- Set IP address on the External Device address in the [Individual Device Settings] dialog box.
- You need to set IP address on the Display in the offline mode of the Display.

■ Settings of External Device

Use the ladder software (MP720 Ver.7) to set up communication settings. Set the next contents.

(1) Main CPU settings

(2) Sub CPU settings

(3) Controller settings

For details on communication settings, please refer to the manual of the External Device.

◆ Main CPU Settings

- 1 Start the ladder software.
- 2 Make a project file. From the [Model] list, select the main CPU.
- 3 From the [Start] tab, click [Module Configuration].
[MC-Configurator] starts up.
- 4 On the CPU you want to use, double-click [218IFD].
- 5 Click the [Parameters] tab.
- 6 In the [Transmission Parameters] group define the [IP Address] and [Subnet Mask] as follows.

Setup Items	Setup Description
IP Address	192.168.0.1
Subnet Mask	255.255.255.0

- 7 Double-click the module number attached to the sub CPU in the [MC-Configurator].
- 8 In the [Module] dialog box, select the sub CPU in use and click [OK].
- 9 In the [MC-Configurator], set the sub CPU circuit number to "5".
Set up the same value as the Display's circuit number.
- 10 Write the settings to the External Device.

IMPORTANT • To write the settings, select the [Save to flash after transferring to the controller] check box.
If the data is transferred without selecting the check box, the transferred data is deleted when restarting the External Device.

◆ Sub CPU Settings

- 1 Start the ladder software.
- 2 Make a project file. Select a Sub CPU to be used from [Model].
- 3 From the tree view, click [Module Configuration].
[MC-Configurator] starts.
- 4 Expand [SVC] of Sub CPU, and double-click [01 UNDEFINED].
- 5 Select the using Controller of [Slave] dialog box, and click [OK].
- 6 Set "1" to the circuit number of [SVC].
- 7 Set "3" to the station address of the added Controller.

8 Write the settings to the Sub CPU.

IMPORTANT

- To write the settings, select the [Save to flash after transferring to the controller] check box.
If the data is transferred without selecting the check box, the transferred data is deleted when restarting the External Device.

◆ Controller Settings

To configure communication settings for the External Device, use the CPU unit's Run, para, enter and cursor keys. Refer to your External Device manual for details.

Procedure

- 1 When [Run] is lit, press and hold the Run key for 3 seconds.
- 2 Press the para key to display parameters.
- 3 Use the up/down cursor keys to display the setup items. (Setup items will blink.)
- 4 Press the enter key to select a setup item.
- 5 Select the settings with the cursor keys. (Settings will blink.)
- 6 Press the enter key to confirm the settings.
- 7 Press the Run key, and [Run] is lit.

Settings

Setup Items	Settings	Setup Description
A09	3	MECHATROLINK-III station address

◆ Notes

- Check with a network administrator about IP address. Do not set the duplicate IP address.

3.31 Setting Example 31

■ Settings of GP-Pro EX

◆ Communication Settings

To display the setup screen, from the [Project] menu, point to [System Settings] and select [Device/PLC].

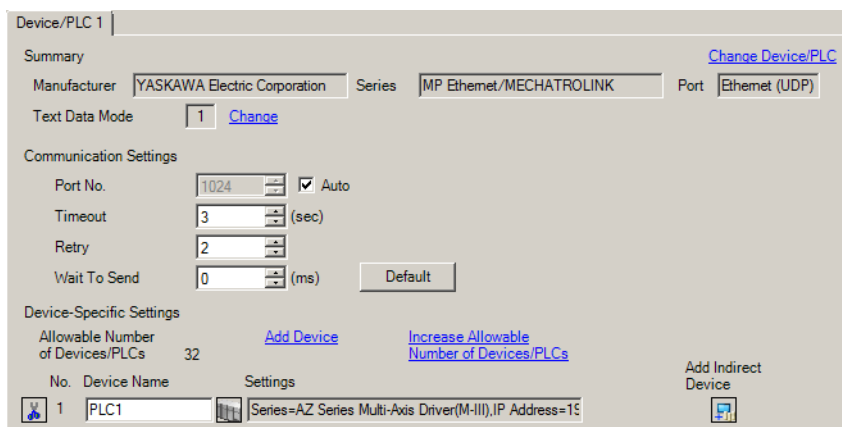

IMPORTANT

- To connect AZ Series using a 1:n connection, [Wait To Send] must be 100ms or more.

◆ Device Setting

To display the [Individual Device Settings] dialog box, from [Device-Specific Settings] in the [Device/PLC] window, select the External Device and click [Settings]. To connect multiple External Devices, from [Device-Specific Settings] in the [Device/PLC] window, click [Add Device] to add another External Device.

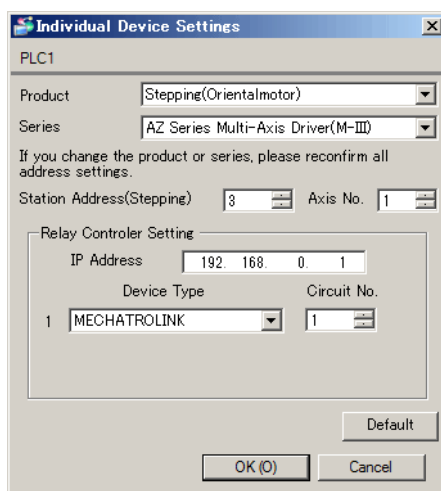

◆ Notes

- Check with a network administrator about IP address. Do not set the duplicate IP address.
- Set IP address on the External Device address in the [Individual Device Settings] dialog box.
- You need to set IP address on the Display in the offline mode of the Display.

■ Settings of External Device

Use the ladder software (MP720 Ver.7.33.0100) to set up communication settings. Set the next contents.

(1) Main CPU settings

(2) Stepping motor settings

For details on communication settings, please refer to the manual of the External Device.

◆ Main CPU Settings

- 1 Start the ladder software.
- 2 Make a project file. From the [Model] list, select the main CPU.
- 3 From the [Start] tab, click [Module Configuration].
[MC-Configurator] starts up.
- 4 On the CPU you want to use, double-click [218IFD].
- 5 Click the [Parameters] tab.
- 6 In the [Transmission Parameters] group define the [IP Address] and [Subnet Mask] as follows.

Setup Items	Setup Description
IP Address	192.168.0.1
Subnet Mask	255.255.255.0

- 7 On the CPU you want to use, set the [SVC32] circuit number to "1".
Set up the same value as the Display's circuit number.
- 8 On the CPU you want to use, open [SVC32], and double-click [01 UNDEFINED].
- 9 In the tree view, from [Stepping], select [Wild Card SteppingMotorDRV], and click [OK].
- 10 For the [Wild Card SteppingMotorDRV] station number, set "3".
- 11 Write the settings to the External Device.

IMPORTANT

- To write the settings, select the [Save to flash after transferring to the controller] check box.

If the data is transferred without selecting the check box, the transferred data is deleted when restarting the External Device.

◆ Stepping Motor Settings

Set up communication settings with rotary switches (S1 and S2).

For details on communication settings, please refer to the manual of the External Device.

Rotary Switch	Settings	Setup Description
S1 (x10)	0	Station address
S2 (x1)	3	

◆ Notes

- Check with a network administrator about IP address. Do not set the duplicate IP address.

3.32 Setting Example 32

■ Settings of GP-Pro EX

◆ Communication Settings

To display the setup screen, from the [Project] menu, point to [System Settings] and select [Device/PLC].

◆ Device Setting

To display the [Individual Device Settings] dialog box, from [Device-Specific Settings] in the [Device/PLC] window, select the External Device and click [Settings]. To connect multiple External Devices, from [Device-Specific Settings] in the [Device/PLC] window, click [Add Device] to add another External Device.

◆ Notes

- Check with a network administrator about IP address. Do not set the duplicate IP address.
- Set IP address on the External Device address in the [Individual Device Settings] dialog box.
- You need to set IP address on the Display in the offline mode of the Display.

■ Settings of External Device

Use the ladder software (MP720 Ver.7) to set up communication settings. Set the next contents.

- (1) Main CPU settings
- (2) MPU-01 settings
- (3) Stepping motor settings

For details on communication settings, please refer to the manual of the External Device.

◆ Main CPU Settings

- 1 Start the ladder software.
- 2 Make a project file. From the [Model] list, select the main CPU.
- 3 From the [Start] tab, click [Module Configuration].
[MC-Configurator] starts up.
- 4 On the CPU you want to use, double-click [218IFD].
- 5 Click the [Parameters] tab.
- 6 In the [Transmission Parameters] group define the [IP Address] and [Subnet Mask] as follows.

Setup Items	Setup Description
IP Address	192.168.0.1
Subnet Mask	255.255.255.0

- 7 Double-click the module number associated with the option slot attached to MPU-01 in the [MC-Configurator].
- 8 In the [Module] dialog box, select [MPU-01] and click [OK].
- 9 In the [MC-Configurator], set [MPU-01]'s circuit number to "3".
Set up the same value as the Display's circuit number.
- 10 Write the settings to the External Device.

IMPORTANT • To write the settings, select the [Save to flash after transferring to the controller] check box.
If the data is transferred without selecting the check box, the transferred data is deleted when restarting the External Device.

◆ MPU-01 Settings

- 1 Start the ladder software.
- 2 Make a project file. Select "MPU-01" from [Model].
- 3 From the tree view, click [Module Configuration].
[MC-Configurator] starts.
- 4 Expand [SVC] of [MPU-01] module, and double-click [01 UNDEFINED].
- 5 In the tree view of [Slave] dialog box, from [Stepping], select [Wild Card SteppingMotorDRV], and click [OK].
- 6 Set "1" to the circuit number of [SVC].
- 7 Set "3" to the station address of the added Wild Card SteppingMotorDRV.

8 Write the settings to the MPU-01 series.

IMPORTANT

- To write the settings, select the [Save to flash after transferring to the controller] check box.
If the data is transferred without selecting the check box, the transferred data is deleted when restarting the External Device.

◆ Stepping Motor Settings

Set up communication settings with rotary switches (S1 and S2).

For details on communication settings, please refer to the manual of the External Device.

Rotary Switch	Settings	Setup Description
S1 (x10)	0	Station address
S2 (x1)	3	

◆ Notes

- Check with a network administrator about IP address. Do not set the duplicate IP address.

3.33 Setting Example 33

■ Settings of GP-Pro EX

◆ Communication Settings

To display the setup screen, from the [Project] menu, point to [System Settings] and select [Device/PLC].

◆ Device Setting

To display the [Individual Device Settings] dialog box, from [Device-Specific Settings] in the [Device/PLC] window, select the External Device and click [Settings]. To connect multiple External Devices, from [Device-Specific Settings] in the [Device/PLC] window, click [Add Device] to add another External Device.

◆ Notes

- Check with a network administrator about IP address. Do not set the duplicate IP address.
- Set IP address on the External Device address in the [Individual Device Settings] dialog box.
- You need to set IP address on the Display in the offline mode of the Display.

■ Settings of External Device

Use the ladder software (MP720 Ver.7) to set up communication settings. Set the next contents.

- (1) Main CPU settings
- (2) Sub CPU settings
- (3) Stepping motor settings

For details on communication settings, please refer to the manual of the External Device.

◆ Main CPU Settings

- 1 Start the ladder software.
- 2 Make a project file. From the [Model] list, select the main CPU.
- 3 From the [Start] tab, click [Module Configuration].
[MC-Configurator] starts up.
- 4 On the CPU you want to use, double-click [218IFD].
- 5 Click the [Parameters] tab.
- 6 In the [Transmission Parameters] group define the [IP Address] and [Subnet Mask] as follows.

Setup Items	Setup Description
IP Address	192.168.0.1
Subnet Mask	255.255.255.0

- 7 Double-click the module number attached to the sub CPU in the [MC-Configurator].
- 8 In the [Module] dialog box, select the sub CPU in use and click [OK].
- 9 In the [MC-Configurator], set the sub CPU circuit number to "5".
Set up the same value as the Display's circuit number.
- 10 Write the settings to the External Device.

IMPORTANT • To write the settings, select the [Save to flash after transferring to the controller] check box.
If the data is transferred without selecting the check box, the transferred data is deleted when restarting the External Device.

◆ Sub CPU Settings

- 1 Start the ladder software.
- 2 Make a project file. Select a Sub CPU to be used from [Model].
- 3 From the tree view, click [Module Configuration].
[MC-Configurator] starts.
- 4 Expand [SVC] of Sub CPU, and double-click [01 UNDEFINED].
- 5 In the tree view of [Slave] dialog box, from [Stepping], select [Wild Card SteppingMotorDRV], and click [OK].
- 6 Set "1" to the circuit number of [SVC].
- 7 Set "3" to the station address of the added Wild Card SteppingMotorDRV.

8 Write the settings to the Sub CPU.

IMPORTANT

- To write the settings, select the [Save to flash after transferring to the controller] check box.
If the data is transferred without selecting the check box, the transferred data is deleted when restarting the External Device.

◆ Stepping Motor Settings

Set up communication settings with rotary switches (S1 and S2).

For details on communication settings, please refer to the manual of the External Device.

Rotary Switch	Settings	Setup Description
S1 (x10)	0	Station address
S2 (x1)	3	

◆ Notes

- Check with a network administrator about IP address. Do not set the duplicate IP address.

3.34 Setting Example 34

■ Settings of GP-Pro EX

◆ Communication Settings

To display the setup screen, from the [Project] menu, point to [System Settings] and select [Device/PLC].

IMPORTANT

- To connect Remote I/O Series using a 1:n connection, [Wait To Send] must be 100ms or more.

◆ Device Setting

To display the [Individual Device Settings] dialog box, from [Device-Specific Settings] in the [Device/PLC] window, select the External Device and click [Settings]. To connect multiple External Devices, from [Device-Specific Settings] in the [Device/PLC] window, click [Add Device] to add another External Device.

◆ Notes

- Check with a network administrator about IP address. Do not set the duplicate IP address.
- Set IP address on the External Device address in the [Individual Device Settings] dialog box.
- You need to set IP address on the Display in the offline mode of the Display.

■ Settings of External Device

Use the ladder software (MP720 Ver.7) to set up communication settings. Set the next contents.

(1) Main CPU settings

(2) Remote I/O settings

For details on communication settings, please refer to the manual of the External Device.

◆ Main CPU Settings

1 Start the ladder software.

2 Make a project file. From the [Model] list, select the main CPU.

3 From the [Start] tab, click [Module Configuration].

[MC-Configurator] starts up.

4 On the CPU you want to use, double-click [218IFD].

5 Click the [Parameters] tab.

6 In the [Transmission Parameters] group define the [IP Address] and [Subnet Mask] as follows.

Setup Items	Setup Description
IP Address	192.168.0.1
Subnet Mask	255.255.255.0

7 On the CPU you want to use, set the [SVC32] circuit number to "1".

Set up the same value as the Display's circuit number.

8 On the CPU you want to use, open [SVC32], and double-click [01 UNDEFINED].

9 In the tree view, from [I/O]-[Other], select [WILDCARD I/O], and click [OK].

10 For the [WILDCARD I/O] station number, set "3".

11 Write the settings to the External Device.

IMPORTANT

- To write the settings, select the [Save to flash after transferring to the controller] check box.

If the data is transferred without selecting the check box, the transferred data is deleted when restarting the External Device.

◆ Remote I/O Settings

Set up communication settings with rotary switches (S1 and S2).

For details on communication settings, please refer to the manual of the External Device.

Rotary Switch	Settings	Setup Description
S1 (x16)	0	Station address
S2 (x1)	3	

◆ Notes

- Check with a network administrator about IP address. Do not set the duplicate IP address.

3.35 Setting Example 35

■ Settings of GP-Pro EX

◆ Communication Settings

To display the setup screen, from the [Project] menu, point to [System Settings] and select [Device/PLC].

Device/PLC 1

Summary [Change Device/PLC](#)

Manufacturer: YASKAWA Electric Corporation Series: MP Ethernet/MECHATROLINK Port: Ethernet (UDP)

Text Data Mode: 1 [Change](#)

Communication Settings

Port No.: 1024 Auto

Timeout: 3 (sec)

Retry: 2

Wait To Send: 0 (ms) [Default](#)

Device-Specific Settings

Allowable Number of Devices/PLCs: 32 [Add Device](#) [Increase Allowable Number of Devices/PLCs](#)

No.	Device Name	Settings	Add Indirect Device
1	PLC1	Series=R7G4HML3-STYVS1(M-III), IP Address=192.16	

◆ Device Setting

To display the [Individual Device Settings] dialog box, from [Device-Specific Settings] in the [Device/PLC] window, select the External Device and click [Settings] . To connect multiple External Devices, from [Device-Specific Settings] in the [Device/PLC] window, click [Add Device] to add another External Device.

Individual Device Settings

PLC1

Product: I/O(M-System)

Series: R7G4HML3-STYVS1(M-III)

If you change the product or series, please reconfirm all address settings.

Station Address(I/O): 3

Relay Controller Setting

IP Address: 192.168.0.1

	Device Type	Circuit No.
1	MPU-01	3
2	MECHATROLINK	1

[Default](#)

[OK \(O\)](#) [Cancel](#)

◆ Notes

- Check with a network administrator about IP address. Do not set the duplicate IP address.
- Set IP address on the External Device address in the [Individual Device Settings] dialog box.
- You need to set IP address on the Display in the offline mode of the Display.

■ Settings of External Device

Use the ladder software (MP720 Ver.7) to set up communication settings. Set the next contents.

- (1) Main CPU settings
- (2) MPU-01 settings
- (3) Remote I/O settings

For details on communication settings, please refer to the manual of the External Device.

◆ Main CPU Settings

- 1 Start the ladder software.
- 2 Make a project file. From the [Model] list, select the main CPU.
- 3 From the [Start] tab, click [Module Configuration].
[MC-Configurator] starts up.
- 4 On the CPU you want to use, double-click [218IFD].
- 5 Click the [Parameters] tab.
- 6 In the [Transmission Parameters] group define the [IP Address] and [Subnet Mask] as follows.

Setup Items	Setup Description
IP Address	192.168.0.1
Subnet Mask	255.255.255.0

- 7 Double-click the module number associated with the option slot attached to MPU-01 in the [MC-Configurator].
- 8 In the [Module] dialog box, select [MPU-01] and click [OK].
- 9 In the [MC-Configurator], set [MPU-01]'s circuit number to "3".
Set up the same value as the Display's circuit number.
- 10 Write the settings to the External Device.

IMPORTANT

- To write the settings, select the [Save to flash after transferring to the controller] check box.
If the data is transferred without selecting the check box, the transferred data is deleted when restarting the External Device.

◆ MPU-01 Settings

- 1 Start the ladder software.
- 2 Make a project file. Select "MPU-01" from [Model].
- 3 From the tree view, click [Module Configuration].
[MC-Configurator] starts.
- 4 Expand [SVC] of [MPU-01] module, and double-click [01 UNDEFINED].
- 5 Select the using Remote I/O of [Slave] dialog box, and click [OK].
- 6 Set "1" to the circuit number of [SVC].
- 7 Set "3" to the station address of the added Remote I/O.

8 Write the settings to the MPU-01 series.

IMPORTANT

- To write the settings, select the [Save to flash after transferring to the controller] check box.
If the data is transferred without selecting the check box, the transferred data is deleted when restarting the External Device.

◆ Remote I/O Settings

Set up communication settings with rotary switches (S1 and S2).

For details on communication settings, please refer to the manual of the External Device.

Rotary Switch	Settings	Setup Description
S1 (x16)	0	Station address
S2 (x1)	3	

◆ Notes

- Check with a network administrator about IP address. Do not set the duplicate IP address.

3.36 Setting Example 36

■ Settings of GP-Pro EX

◆ Communication Settings

To display the setup screen, from the [Project] menu, point to [System Settings] and select [Device/PLC].

◆ Device Setting

To display the [Individual Device Settings] dialog box, from [Device-Specific Settings] in the [Device/PLC] window, select the External Device and click [Settings]. To connect multiple External Devices, from [Device-Specific Settings] in the [Device/PLC] window, click [Add Device] to add another External Device.

◆ Notes

- Check with a network administrator about IP address. Do not set the duplicate IP address.
- Set IP address on the External Device address in the [Individual Device Settings] dialog box.
- You need to set IP address on the Display in the offline mode of the Display.

■ Settings of External Device

Use the ladder software (MP720 Ver.7) to set up communication settings. Set the next contents.

(1) Main CPU settings

(2) MPU-01 settings

(3) Remote I/O settings

For details on communication settings, please refer to the manual of the External Device.

◆ Main CPU Settings

- 1 Start the ladder software.
- 2 Make a project file. From the [Model] list, select the main CPU.
- 3 From the [Start] tab, click [Module Configuration].
[MC-Configurator] starts up.
- 4 On the CPU you want to use, double-click [218IFD].
- 5 Click the [Parameters] tab.
- 6 In the [Transmission Parameters] group define the [IP Address] and [Subnet Mask] as follows.

Setup Items	Setup Description
IP Address	192.168.0.1
Subnet Mask	255.255.255.0

- 7 Double-click the module number attached to the sub CPU in the [MC-Configurator].
- 8 In the [Module] dialog box, select the sub CPU in use and click [OK].
- 9 In the [MC-Configurator], set the sub CPU circuit number to "5".
Set up the same value as the Display's circuit number.
- 10 Write the settings to the External Device.

IMPORTANT

- To write the settings, select the [Save to flash after transferring to the controller] check box.
If the data is transferred without selecting the check box, the transferred data is deleted when restarting the External Device.

◆ Sub CPU Settings

- 1 Start the ladder software.
- 2 Make a project file. Select a Sub CPU to be used from [Model].
- 3 From the tree view, click [Module Configuration].
[MC-Configurator] starts.
- 4 Expand [SVC] of Sub CPU, and double-click [01 UNDEFINED].
- 5 Select the using Remote I/O of [Slave] dialog box, and click [OK].
- 6 Set "1" to the circuit number of [SVC].
- 7 Set "3" to the station address of the added Remote I/O.

8 Write the settings to the Sub CPU.

IMPORTANT

- To write the settings, select the [Save to flash after transferring to the controller] check box.
If the data is transferred without selecting the check box, the transferred data is deleted when restarting the External Device.

◆ Remote I/O Settings

Set up communication settings with rotary switches (S1 and S2).

For details on communication settings, please refer to the manual of the External Device.

Rotary Switch	Settings	Setup Description
S1 (x16)	0	Station address
S2 (x1)	3	

◆ Notes

- Check with a network administrator about IP address. Do not set the duplicate IP address.

3.37 Setting Example 37

■ Settings of GP-Pro EX

◆ Communication Settings

To display the setup screen, from the [Project] menu, point to [System Settings] and select [Device/PLC].

IMPORTANT

- To connect Remote I/O Series using a 1:n connection, [Wait To Send] must be 100ms or more.

◆ Device Setting

To display the [Individual Device Settings] dialog box, from [Device-Specific Settings] in the [Device/PLC] window, select the External Device and click [Settings]. To connect multiple External Devices, from [Device-Specific Settings] in the [Device/PLC] window, click [Add Device] to add another External Device.

◆ Notes

- Check with a network administrator about IP address. Do not set the duplicate IP address.
- Set IP address on the External Device address in the [Individual Device Settings] dialog box.
- You need to set IP address on the Display in the offline mode of the Display.

■ Settings of External Device

Use the ladder software (MP720 Ver.7) to set up communication settings. Set the next contents.

(1) Main CPU settings

(2) Remote I/O settings

For details on communication settings, please refer to the manual of the External Device.

◆ Main CPU Settings

- 1 Start the ladder software.
- 2 Make a project file. From the [Model] list, select the main CPU.
- 3 From the [Start] tab, click [Module Configuration].
[MC-Configurator] starts up.
- 4 On the CPU you want to use, double-click [218IFD].
- 5 Click the [Parameters] tab.
- 6 In the [Transmission Parameters] group define the [IP Address] and [Subnet Mask] as follows.

Setup Items	Setup Description
IP Address	192.168.0.1
Subnet Mask	255.255.255.0

- 7 On the CPU you want to use, set the [SVC32] circuit number to "1".
Set up the same value as the Display's circuit number.
- 8 On the CPU you want to use, open [SVC32], and double-click [01 UNDEFINED].
- 9 In the tree view, from [I/O]-[Other], select [WILDCARD I/O], and click [OK].
- 10 For the [WILDCARD I/O] station number, set "3".
- 11 Write the settings to the External Device.

IMPORTANT • To write the settings, select the [Save to flash after transferring to the controller] check box.
If the data is transferred without selecting the check box, the transferred data is deleted when restarting the External Device.

◆ Remote I/O Settings

Set up communication settings with rotary switches (S1 and S2).

For details on communication settings, please refer to the manual of the External Device.

Rotary Switch	Settings	Setup Description
S1 (x16)	0	Station address
S2 (x1)	3	

◆ Notes

- Check with a network administrator about IP address. Do not set the duplicate IP address.

3.38 Setting Example 38

■ Settings of GP-Pro EX

◆ Communication Settings

To display the setup screen, from the [Project] menu, point to [System Settings] and select [Device/PLC].

◆ Device Setting

To display the [Individual Device Settings] dialog box, from [Device-Specific Settings] in the [Device/PLC] window, select the External Device and click [Settings]. To connect multiple External Devices, from [Device-Specific Settings] in the [Device/PLC] window, click [Add Device] to add another External Device.

◆ Notes

- Check with a network administrator about IP address. Do not set the duplicate IP address.
- Set IP address on the External Device address in the [Individual Device Settings] dialog box.
- You need to set IP address on the Display in the offline mode of the Display.

■ Settings of External Device

Use the ladder software (MP720 Ver.7) to set up communication settings. Set the next contents.

(1) Main CPU settings

(2) MPU-01 settings

(3) Remote I/O settings

For details on communication settings, please refer to the manual of the External Device.

◆ Main CPU Settings

- 1 Start the ladder software.
- 2 Make a project file. From the [Model] list, select the main CPU.
- 3 From the [Start] tab, click [Module Configuration].
[MC-Configurator] starts up.
- 4 On the CPU you want to use, double-click [218IFD].
- 5 Click the [Parameters] tab.
- 6 In the [Transmission Parameters] group define the [IP Address] and [Subnet Mask] as follows.

Setup Items	Setup Description
IP Address	192.168.0.1
Subnet Mask	255.255.255.0

- 7 Double-click the module number associated with the option slot attached to MPU-01 in the [MC-Configurator].
- 8 In the [Module] dialog box, select [MPU-01] and click [OK].
- 9 In the [MC-Configurator], set [MPU-01]'s circuit number to "3".
Set up the same value as the Display's circuit number.
- 10 Write the settings to the External Device.

IMPORTANT

- To write the settings, select the [Save to flash after transferring to the controller] check box.
If the data is transferred without selecting the check box, the transferred data is deleted when restarting the External Device.

◆ MPU-01 Settings

- 1 Start the ladder software.
- 2 Make a project file. Select "MPU-01" from [Model].
- 3 From the tree view, click [Module Configuration].
[MC-Configurator] starts.
- 4 Expand [SVC] of [MPU-01] module, and double-click [01 UNDEFINED].
- 5 Select the using Remote I/O of [Slave] dialog box, and click [OK].
- 6 Set "1" to the circuit number of [SVC].
- 7 Set "3" to the station address of the added Remote I/O.

8 Write the settings to the MPU-01 series.

IMPORTANT

- To write the settings, select the [Save to flash after transferring to the controller] check box.
If the data is transferred without selecting the check box, the transferred data is deleted when restarting the External Device.

◆ Remote I/O Settings

Set up communication settings with rotary switches (S1 and S2).

For details on communication settings, please refer to the manual of the External Device.

Rotary Switch	Settings	Setup Description
S1 (x16)	0	Station address
S2 (x1)	3	

◆ Notes

- Check with a network administrator about IP address. Do not set the duplicate IP address.

3.39 Setting Example 39

■ Settings of GP-Pro EX

◆ Communication Settings

To display the setup screen, from the [Project] menu, point to [System Settings] and select [Device/PLC].

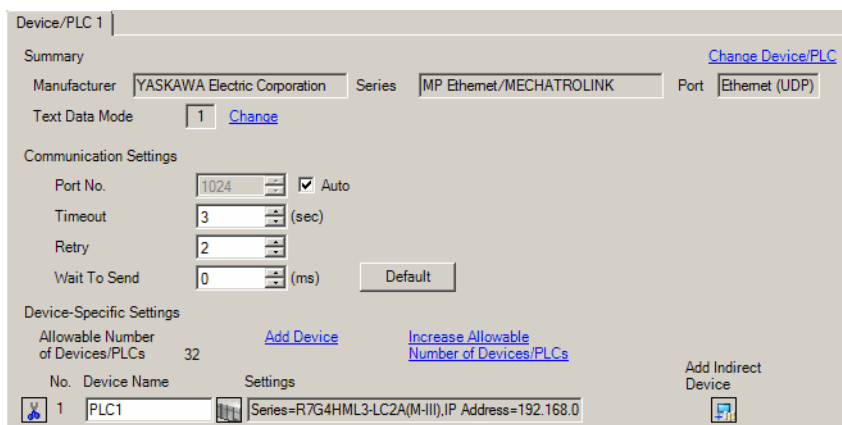

◆ Device Setting

To display the [Individual Device Settings] dialog box, from [Device-Specific Settings] in the [Device/PLC] window, select the External Device and click [Settings]. To connect multiple External Devices, from [Device-Specific Settings] in the [Device/PLC] window, click [Add Device] to add another External Device.

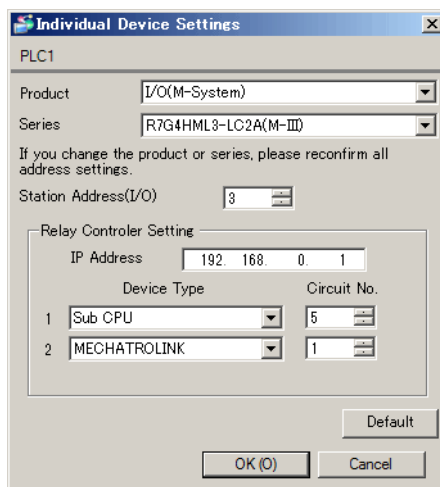

◆ Notes

- Check with a network administrator about IP address. Do not set the duplicate IP address.
- Set IP address on the External Device address in the [Individual Device Settings] dialog box.
- You need to set IP address on the Display in the offline mode of the Display.

■ Settings of External Device

Use the ladder software (MP720 Ver.7) to set up communication settings. Set the next contents.

(1) Main CPU settings

(2) MPU-01 settings

(3) Remote I/O settings

For details on communication settings, please refer to the manual of the External Device.

◆ Main CPU Settings

- 1 Start the ladder software.
- 2 Make a project file. From the [Model] list, select the main CPU.
- 3 From the [Start] tab, click [Module Configuration].
[MC-Configurator] starts up.
- 4 On the CPU you want to use, double-click [218IFD].
- 5 Click the [Parameters] tab.
- 6 In the [Transmission Parameters] group define the [IP Address] and [Subnet Mask] as follows.

Setup Items	Setup Description
IP Address	192.168.0.1
Subnet Mask	255.255.255.0

- 7 Double-click the module number attached to the sub CPU in the [MC-Configurator].
- 8 In the [Module] dialog box, select the sub CPU in use and click [OK].
- 9 In the [MC-Configurator], set the sub CPU circuit number to "5".
Set up the same value as the Display's circuit number.
- 10 Write the settings to the External Device.

IMPORTANT

- To write the settings, select the [Save to flash after transferring to the controller] check box.
If the data is transferred without selecting the check box, the transferred data is deleted when restarting the External Device.

◆ Sub CPU Settings

- 1 Start the ladder software.
- 2 Make a project file. Select a Sub CPU to be used from [Model].
- 3 From the tree view, click [Module Configuration].
[MC-Configurator] starts.
- 4 Expand [SVC] of Sub CPU, and double-click [01 UNDEFINED].
- 5 Select the using Remote I/O of [Slave] dialog box, and click [OK].
- 6 Set "1" to the circuit number of [SVC].
- 7 Set "3" to the station address of the added Remote I/O.

8 Write the settings to the Sub CPU.

IMPORTANT

- To write the settings, select the [Save to flash after transferring to the controller] check box.
If the data is transferred without selecting the check box, the transferred data is deleted when restarting the External Device.

◆ Remote I/O Settings

Set up communication settings with rotary switches (S1 and S2).

For details on communication settings, please refer to the manual of the External Device.

Rotary Switch	Settings	Setup Description
S1 (x16)	0	Station address
S2 (x1)	3	

◆ Notes

- Check with a network administrator about IP address. Do not set the duplicate IP address.

3.40 Setting Example 40

■ Settings of GP-Pro EX

◆ Communication Settings

To display the setup screen, from the [Project] menu, point to [System Settings] and select [Device/PLC].

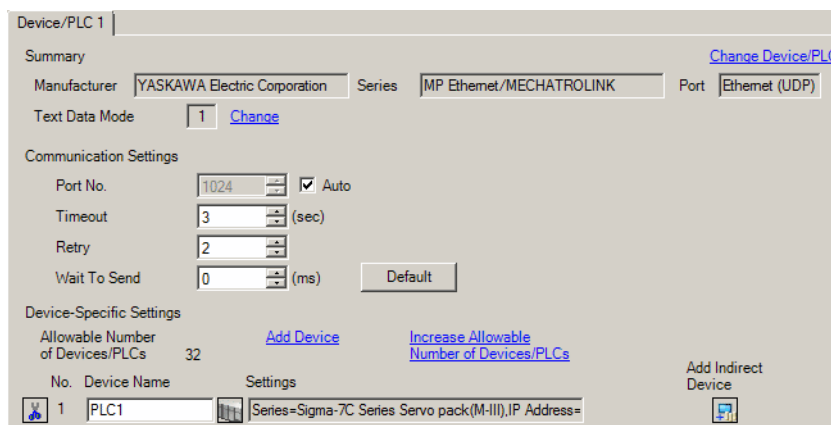

◆ Device Setting

To display the [Individual Device Settings] dialog box, from [Device-Specific Settings] in the [Device/PLC] window, select the External Device and click [Settings]. To connect multiple External Devices, from [Device-Specific Settings] in the [Device/PLC] window, click [Add Device] to add another External Device.

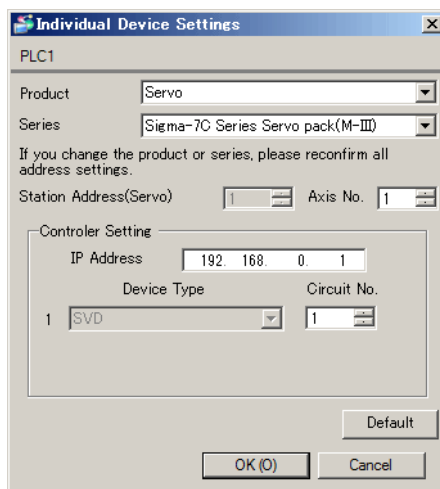

◆ Notes

- Check with a network administrator about IP address. Do not set the duplicate IP address.
- Set IP address on the External Device address in the [Individual Device Settings] dialog box.
- You need to set the Display's IP address in its offline mode.

■ Settings of External Device

Use the ladder software (MP720 Ver.7) to set up communication settings.

For details on communication settings, please refer to the manual of the External Device.

1 Start the ladder software.

2 Make a project file.

In the [TypeSelect] area, set the [Series] and [Controller].

Setup Items	Setup Description
Series	MP3000
Controller	SIGMA-7C

3 Click [Module Configuration] to start [MC-Configurator].

4 Double-click [218IFD] on the CPU you want to use.

5 Click the [Transmission Parameters] tab.

6 In [Transmission Parameters], set the [IP Address] and [Subnet Mask].

Setup Items	Setup Description
IP Address	192.168.0.1
Subnet Mask	255.255.255.0

7 For the CPU you want to use in [MC-Configurator], set [SVD] to [Circuit No1].

8 Write the settings to the External Device.

9 Turn ON the External Device again.

◆ Notes

- Check with a network administrator about IP address. Do not set the duplicate IP address.

3.41 Setting Example 41

■ Settings of GP-Pro EX

◆ Communication Settings

To display the setup screen, from the [Project] menu, point to [System Settings] and select [Device/PLC].

IMPORTANT

- To connect Σ -X Series using a 1:n connection, [Wait To Send] must be 100ms or more.

◆ Device Setting

To display the [Individual Device Settings] dialog box, from [Device-Specific Settings] in the [Device/PLC] window, select the External Device and click [Settings]. To connect multiple External Devices, from [Device-Specific Settings] in the [Device/PLC] window, click [Add Device] to add another External Device.

◆ Notes

- Check with a network administrator about IP address. Do not set the duplicate IP address.
- Set IP address on the External Device address in the [Individual Device Settings] dialog box.
- You need to set IP address on the Display in the offline mode of the Display.

■ Settings of External Device

Set communication settings for both MP and Σ -X Series.

◆ MP Series Setting

Use the ladder software (MPE720) to set up communication settings.

For details on communication settings, please refer to the manual of the External Device.

- 1 Start the ladder software.
- 2 Make a project file.
- 3 From the tree view, double-click [Module Configuration].
[Engineering Manager] starts.
- 4 In the [Create new file] dialog box, click [OK].
- 5 In the [Engineering Manager]'s [Controller], use the pull-down menu to select MECHATROLINK connection module.
Select the number associated with the slot number used by the module.
When you select the MECHATROLINK connection module, its setting information is displayed in the [Engineering Manger]'s [Module details].
- 6 In the [module Details]'s [Circuit Number] field, enter "01".
Set up the same value as the Display's circuit number.
- 7 In [Details], double-click [MECHATROLINK].
- 8 Click the [Link Assignments] tab, and then [ST#]'s [01] as follows.

Setup Items	Setup Description
ADR	03H
ExADR	00
VENDOR	Yaskawa Electric co.
DEVICE	Σ -X Series type

NOTE

- [PROFILE], [BYTE] and [SCAN] are defined automatically.

- 9 In the [Engineering Manager]'s [Controller], select CPU.
- 10 In the [Module details], double-click the communication module's No. field.
- 11 Set [Transmission Parameters] as follows.

Setup Items	Setup Description
IP Address	192.168.0.1
Subnet Mask	255.255.255.0

- 12 From the [File] menu select [Save] to save your settings, and exit [Engineering Manager].
- 13 Write the settings to MP Series.

IMPORTANT

- To write the settings, select the [Save to flash after transferring to the controller] check box.
If the data is transferred without selecting the check box, the transferred data is deleted when restarting the External Device.

◆ Σ -X Series Setting

Set up communication settings with the DIP Switch (SW3) and the rotary switches (S1 and S2).
For details on communication settings, please refer to the manual of the External Device.

- DIP Switch (SW3) Setting

DIP Switch	Settings	Setup Description
1	Optional	Transmission byte size
2		
3	ON	Communication protocol: MECHATROLINK-III
4	OFF	Always OFF

- Rotary switches (S1 and S2) Setting

Rotary Switch	Settings	Setup Description
S1 (x16)	0	Station address
S2 (x1)	3	

◆ Notes

- Check with a network administrator about IP address. Do not set the duplicate IP address.

3.42 Setting Example 42

■ Settings of GP-Pro EX

◆ Communication Settings

To display the setup screen, from the [Project] menu, point to [System Settings] and select [Device/PLC].

Device/PLC 1

Summary [Change Device/PLC](#)

Manufacturer: YASKAWA Electric Corporation Series: MP Ethernet/MECHATROLINK Port: Ethernet (UDP)

Text Data Mode: 1 [Change](#)

Communication Settings

Port No.: 1024 Auto

Timeout: 3 (sec)

Retry: 2

Wait To Send: 0 (ms) [Default](#)

Device-Specific Settings

Allowable Number of Devices/PLCs: 32 [Add Device](#) [Increase Allowable Number of Devices/PLCs](#)

Add Indirect Device [+](#)

No.	Device Name	Settings
1	PLC1	Series=Sigma-XS Series Servo pack(M-III).IP Address=

◆ Device Setting

To display the [Individual Device Settings] dialog box, from [Device-Specific Settings] in the [Device/PLC] window, select the External Device and click [Settings]. To connect multiple External Devices, from [Device-Specific Settings] in the [Device/PLC] window, click [Add Device] to add another External Device.

Individual Device Settings

PLC1

Product: Servo

Series: Sigma-XS Series Servo pack(M-III)

If you change the product or series, please reconfirm all address settings.

Station Address(Servo): 3

Relay Controller Setting

IP Address: 192.168.0.1

	Device Type	Circuit No.
1	MPU-01	3
2	MECHATROLINK	1

[Default](#) [OK \(O\)](#) [Cancel](#)

◆ Notes

- Check with a network administrator about IP address. Do not set the duplicate IP address.
- Set IP address on the External Device address in the [Individual Device Settings] dialog box.
- You need to set IP address on the Display in the offline mode of the Display.

■ Settings of External Device

Use the ladder software (MP720 Ver.7) to set up communication settings. Set the next contents.

- (1) Main CPU settings
- (2) MPU-01 settings
- (3) Σ -X series settings

For details on communication settings, please refer to the manual of the External Device.

◆ Main CPU Settings

- 1 Start the ladder software.
- 2 Make a project file. Select the main CPU models from [Model].
- 3 From the tree view, double-click [Module Configuration].
[MC-Configurator] starts.
- 4 Double-click [218IFD] on the CPU to use.
- 5 Click [Parameters] tab.
- 6 Set "IP Address" and "Subnet Mask" of "Transmission Parameters".

Setup Items	Setup Description
IP Address	192.168.0.1
Subnet Mask	255.255.255.0

- 7 Double-click the module number corresponding to the option slot which attaches MPU-01 in the [MC-Configurator]
- 8 Select [MPU-01] in the [Module] dialog box, and click [OK].
- 9 Set "3" to the circuit number of MPU-01 that displayed in the [MC-Configurator].
Set up the same value as the Display's circuit number.
- 10 Write the settings to the External Device.

IMPORTANT • To write the settings, select the [Save to flash after transferring to the controller] check box.
If the data is transferred without selecting the check box, the transferred data is deleted when restarting the External Device.

◆ MPU-01 Settings

- 1 Start the ladder software.
- 2 Make a project file. Select "MPU-01" from [Model].
- 3 From the tree view, double-click [Module Configuration].
[MC-Configurator] starts.
- 4 Expand [SVC] of [MPU-01] module, and double-click [01 UNDEFINED].
- 5 Select the using Σ -X series of [Slave] dialog box, and click [OK].
- 6 Set "1" to the circuit number of [SVC].
- 7 Set "3" to the station address of the added Σ -X series.

8 Write the settings to the MPU-01 series.

IMPORTANT

- To write the settings, select the [Save to flash after transferring to the controller] check box.
If the data is transferred without selecting the check box, the transferred data is deleted when restarting the External Device.

◆ Σ-X Series Setting

Set up communication settings with the DIP Switch (SW3) and the rotary switches (S1 and S2).
For details on communication settings, please refer to the manual of the External Device.

• DIP Switch (SW3) Setting

DIP Switch	Settings	Setup Description
1	Optional	Transmission byte size
2		
3	ON	Communication protocol: MECHATROLINK-III
4	OFF	Always OFF

• Rotary switches (S1 and S2) Setting

Rotary Switch	Settings	Setup Description
S1 (x16)	0	Station address
S2 (x1)	3	

◆ Notes

- Check with a network administrator about IP address. Do not set the duplicate IP address.

3.43 Setting Example 43

■ Settings of GP-Pro EX

◆ Communication Settings

To display the setup screen, from the [Project] menu, point to [System Settings] and select [Device/PLC].

Device/PLC 1

Summary [Change Device/PLC](#)

Manufacturer Series Port

Text Data Mode [Change](#)

Communication Settings

Port No. Auto

Timeout (sec)

Retry

Wait To Send (ms)

Device-Specific Settings

Allowable Number of Devices/PLCs 32 [Add Device](#) [Increase Allowable Number of Devices/PLCs](#)

No.	Device Name	Settings	Add Indirect Device
1	PLC1	Series=Sigma-XS Series Servo pack(M-III).IP Address=	<input type="button" value="Add"/>

◆ Device Setting

To display the [Individual Device Settings] dialog box, from [Device-Specific Settings] in the [Device/PLC] window, select the External Device and click [Settings]. To connect multiple External Devices, from [Device-Specific Settings] in the [Device/PLC] window, click [Add Device] to add another External Device.

Individual Device Settings

PLC1

Product

Series

If you change the product or series, please reconfirm all address settings.

Station Address(Servo)

Relay Controller Setting

IP Address

	Device Type	Circuit No.
1	Sub CPU	5
2	MECHATROLINK	1

◆ Notes

- Check with a network administrator about IP address. Do not set the duplicate IP address.
- Set IP address on the External Device address in the [Individual Device Settings] dialog box.
- You need to set IP address on the Display in the offline mode of the Display.

■ Settings of External Device

Use the ladder software (MP720 Ver.7) to set up communication settings. Set the next contents.

- (1) Main CPU settings
- (2) Sub CPU settings
- (3) Σ -X series settings

For details on communication settings, please refer to the manual of the External Device.

◆ Main CPU Settings

- 1 Start the ladder software.
- 2 Make a project file. Select the main CPU models from [Model].
- 3 From the tree view, double-click [Module Configuration].
[MC-Configurator] starts.
- 4 Double-click [218IFD] on the CPU to use.
- 5 Click [Parameters] tab.
- 6 Set "IP Address" and "Subnet Mask" of "Transmission Parameters".

Setup Items	Setup Description
IP Address	192.168.0.1
Subnet Mask	255.255.255.0

- 7 Double-click the number of module which attaches a sub CPU in [MC-Configurator].
- 8 Select a sub CPU to be used in the [Module] dialog box, and click [OK].
- 9 Set "5" to the circuit number of Sub CPU that displayed in the [MC-Configurator].
Set up the same value as the Display's circuit number.
- 10 Write the settings to the External Device.

IMPORTANT

- To write the settings, select the [Save to flash after transferring to the controller] check box.
If the data is transferred without selecting the check box, the transferred data is deleted when restarting the External Device.

◆ Sub CPU Settings

- 1 Start the ladder software.
- 2 Make a project file. Select a Sub CPU to be used from [Model].
- 3 From the tree view, double-click [Module Configuration].
[MC-Configurator] starts.
- 4 Expand [SVC] of Sub CPU, and double-click [01 UNDEFINED].
- 5 Select the using Σ -X series of [Slave] dialog box, and click [OK].
- 6 Set "1" to the circuit number of [SVC].
- 7 Set "3" to the station address of the added Σ -X series.

8 Write the settings to the Sub CPU.

IMPORTANT

- To write the settings, select the [Save to flash after transferring to the controller] check box.
If the data is transferred without selecting the check box, the transferred data is deleted when restarting the External Device.

◆ Σ -X Series Setting

Set up communication settings with the DIP Switch (SW3) and the rotary switches (S1 and S2).
For details on communication settings, please refer to the manual of the External Device.

- DIP Switch (SW3) Setting

DIP Switch	Settings	Setup Description
1	Optional	Transmission byte size
2		
3	ON	Communication protocol: MECHATROLINK-III
4	OFF	Always OFF

- Rotary switches (S1 and S2) Setting

Rotary Switch	Settings	Setup Description
S1 (x16)	0	Station address
S2 (x1)	3	

◆ Notes

- Check with a network administrator about IP address. Do not set the duplicate IP address.

3.44 Setting Example 44

■ Settings of GP-Pro EX

◆ Communication Settings

To display the setup screen, from the [Project] menu, point to [System Settings] and select [Device/PLC].

IMPORTANT

- To connect Σ -X Series using a 1:n connection, [Wait To Send] must be 100ms or more.

◆ Device Setting

To display the [Individual Device Settings] dialog box, from [Device-Specific Settings] in the [Device/PLC] window, select the External Device and click [Settings]. To connect multiple External Devices, from [Device-Specific Settings] in the [Device/PLC] window, click [Add Device] to add another External Device.

◆ Notes

- Check with a network administrator about IP address. Do not set the duplicate IP address.
- Set IP address on the External Device address in the [Individual Device Settings] dialog box.
- You need to set IP address on the Display in the offline mode of the Display.

■ Settings of External Device

Set communication settings for both MP and Σ -X Series.

◆ MP Series Setting

Use the ladder software (MPE720) to set up communication settings.

For details on communication settings, please refer to the manual of the External Device.

- 1 Start the ladder software.
- 2 Make a project file.
- 3 From the tree view, double-click [Module Configuration].
[Engineering Manager] starts.
- 4 In the [Create new file] dialog box, click [OK].
- 5 In the [Engineering Manager]'s [Controller], use the pull-down menu to select MECHATROLINK connection module.
Select the number associated with the slot number used by the module.
When you select the MECHATROLINK connection module, its setting information is displayed in the [Engineering Manger]'s [Module details].
- 6 In the [module Details]'s [Circuit Number] field, enter "01".
Set up the same value as the Display's circuit number.
- 7 In [Details], double-click [MECHATROLINK].
- 8 Click the [Link Assignments] tab, and then [ST#]'s [01] as follows.

Setup Items	Setup Description
ADR	03H
ExADR	00
VENDOR	Yaskawa Electric co.
DEVICE	Σ -X Series type

NOTE

- [PROFILE], [BYTE] and [SCAN] are defined automatically.

- 9 In the [Engineering Manager]'s [Controller], select CPU.
- 10 In the [Module details], double-click the communication module's No. field.
- 11 Set [Transmission Parameters] as follows.

Setup Items	Setup Description
IP Address	192.168.0.1
Subnet Mask	255.255.255.0

- 12 From the [File] menu select [Save] to save your settings, and exit [Engineering Manager].
- 13 Write the settings to MP Series.

IMPORTANT

- To write the settings, select the [Save to flash after transferring to the controller] check box.
If the data is transferred without selecting the check box, the transferred data is deleted when restarting the External Device.

◆ Σ -X Series Setting

Set up communication settings with the DIP Switch (SW3) and the rotary switches (S1 and S2).
For details on communication settings, please refer to the manual of the External Device.

- DIP Switch (SW3) Setting

DIP Switch	Settings	Setup Description
1	Optional	Transmission byte size
2		
3	ON	Communication protocol: MECHATROLINK-III
4	OFF	Always OFF

- Rotary switches (S1 and S2) Setting

Rotary Switch	Settings	Setup Description
S1 (x16)	0	Station address
S2 (x1)	3	

◆ Notes

- Check with a network administrator about IP address. Do not set the duplicate IP address.

3.45 Setting Example 45

■ Settings of GP-Pro EX

◆ Communication Settings

To display the setup screen, from the [Project] menu, point to [System Settings] and select [Device/PLC].

Device/PLC 1

Summary [Change Device/PLC](#)

Manufacturer: YASKAWA Electric Corporation Series: MP Ethernet/MECHATROLINK Port: Ethernet (UDP)

Text Data Mode: 1 [Change](#)

Communication Settings

Port No.: 1024 Auto

Timeout: 3 (sec)

Retry: 2

Wait To Send: 0 (ms) [Default](#)

Device-Specific Settings

Allowable Number of Devices/PLCs: 32 [Add Device](#) [Increase Allowable Number of Devices/PLCs](#)

Add Indirect Device

No.	Device Name	Settings
1	PLC1	Series=Sigma-XW Series Servo pack(M-III),IP Address

◆ Device Setting

To display the [Individual Device Settings] dialog box, from [Device-Specific Settings] in the [Device/PLC] window, select the External Device and click [Settings]. To connect multiple External Devices, from [Device-Specific Settings] in the [Device/PLC] window, click [Add Device] to add another External Device.

Individual Device Settings

PLC1

Product: Servo

Series: Sigma-XW Series Servo pack(M-III)

If you change the product or series, please reconfirm all address settings.

Station Address(Servo): 3 Axis No.: 1

Relay Controller Setting

IP Address: 192.168.0.1

	Device Type	Circuit No.
1	MPU-01	3
2	MECHATROLINK	1

[Default](#)

[OK \(O\)](#) [Cancel](#)

◆ Notes

- Check with a network administrator about IP address. Do not set the duplicate IP address.
- Set IP address on the External Device address in the [Individual Device Settings] dialog box.
- You need to set IP address on the Display in the offline mode of the Display.

■ Settings of External Device

Use the ladder software (MP720 Ver.7) to set up communication settings. Set the next contents.

- (1) Main CPU settings
- (2) MPU-01 settings
- (3) Σ -X series settings

For details on communication settings, please refer to the manual of the External Device.

◆ Main CPU Settings

- 1 Start the ladder software.
- 2 Make a project file. Select the main CPU models from [Model].
- 3 From the tree view, double-click [Module Configuration].
[MC-Configurator] starts.
- 4 Double-click [218IFD] on the CPU to use.
- 5 Click [Parameters] tab.
- 6 Set "IP Address" and "Subnet Mask" of "Transmission Parameters".

Setup Items	Setup Description
IP Address	192.168.0.1
Subnet Mask	255.255.255.0

- 7 Double-click the module number corresponding to the option slot which attaches MPU-01 in the [MC-Configurator]
- 8 Select [MPU-01] in the [Module] dialog box, and click [OK].
- 9 Set "3" to the circuit number of MPU-01 that displayed in the [MC-Configurator].
Set up the same value as the Display's circuit number.
- 10 Write the settings to the External Device.

IMPORTANT • To write the settings, select the [Save to flash after transferring to the controller] check box.
If the data is transferred without selecting the check box, the transferred data is deleted when restarting the External Device.

◆ MPU-01 Settings

- 1 Start the ladder software.
- 2 Make a project file. Select "MPU-01" from [Model].
- 3 From the tree view, double-click [Module Configuration].
[MC-Configurator] starts.
- 4 Expand [SVC] of [MPU-01] module, and double-click [01 UNDEFINED].
- 5 Select the using Σ -X series of [Slave] dialog box, and click [OK].
- 6 Set "1" to the circuit number of [SVC].
- 7 Set "3" to the station address of the added Σ -X series.

8 Write the settings to the MPU-01 series.

IMPORTANT

- To write the settings, select the [Save to flash after transferring to the controller] check box.
If the data is transferred without selecting the check box, the transferred data is deleted when restarting the External Device.

◆ Σ-X Series Setting

Set up communication settings with the DIP Switch (SW3) and the rotary switches (S1 and S2).
For details on communication settings, please refer to the manual of the External Device.

• DIP Switch (SW3) Setting

DIP Switch	Settings	Setup Description
1	Optional	Transmission byte size
2		
3	ON	Communication protocol: MECHATROLINK-III
4	OFF	Always OFF

• Rotary switches (S1 and S2) Setting

Rotary Switch	Settings	Setup Description
S1 (x16)	0	Station address
S2 (x1)	3	

◆ Notes

- Check with a network administrator about IP address. Do not set the duplicate IP address.

3.46 Setting Example 46

■ Settings of GP-Pro EX

◆ Communication Settings

To display the setup screen, from the [Project] menu, point to [System Settings] and select [Device/PLC].

Device/PLC 1

Summary [Change Device/PLC](#)

Manufacturer Series Port

Text Data Mode [Change](#)

Communication Settings

Port No. Auto

Timeout (sec)

Retry

Wait To Send (ms)

Device-Specific Settings

Allowable Number of Devices/PLCs 32 [Add Device](#) [Increase Allowable Number of Devices/PLCs](#)

No.	Device Name	Settings
1	PLC1	Series=Sigma-XW Series Servo pack(M-III),IP Address

◆ Device Setting

To display the [Individual Device Settings] dialog box, from [Device-Specific Settings] in the [Device/PLC] window, select the External Device and click [Settings]. To connect multiple External Devices, from [Device-Specific Settings] in the [Device/PLC] window, click [Add Device] to add another External Device.

Individual Device Settings

PLC1

Product

Series

If you change the product or series, please reconfirm all address settings.

Station Address(Servo) Axis No.

Relay Controller Setting

IP Address

	Device Type	Circuit No.
1	<input type="text" value="Sub CPU"/>	<input type="text" value="5"/>
2	<input type="text" value="MECHATROLINK"/>	<input type="text" value="1"/>

◆ Notes

- Check with a network administrator about IP address. Do not set the duplicate IP address.
- Set IP address on the External Device address in the [Individual Device Settings] dialog box.
- You need to set IP address on the Display in the offline mode of the Display.

■ Settings of External Device

Use the ladder software (MP720 Ver.7) to set up communication settings. Set the next contents.

- (1) Main CPU settings
- (2) Sub CPU settings
- (3) Σ -X series settings

For details on communication settings, please refer to the manual of the External Device.

◆ Main CPU Settings

- 1 Start the ladder software.
- 2 Make a project file. Select the main CPU models from [Model].
- 3 From the tree view, double-click [Module Configuration].
[MC-Configurator] starts.
- 4 Double-click [218IFD] on the CPU to use.
- 5 Click [Parameters] tab.
- 6 Set "IP Address" and "Subnet Mask" of "Transmission Parameters".

Setup Items	Setup Description
IP Address	192.168.0.1
Subnet Mask	255.255.255.0

- 7 Double-click the number of module which attaches a sub CPU in [MC-Configurator].
- 8 Select a sub CPU to be used in the [Module] dialog box, and click [OK].
- 9 Set "5" to the circuit number of Sub CPU that displayed in the [MC-Configurator].
Set up the same value as the Display's circuit number.
- 10 Write the settings to the External Device.

IMPORTANT

- To write the settings, select the [Save to flash after transferring to the controller] check box.
If the data is transferred without selecting the check box, the transferred data is deleted when restarting the External Device.

◆ Sub CPU Settings

- 1 Start the ladder software.
- 2 Make a project file. Select a Sub CPU to be used from [Model].
- 3 From the tree view, double-click [Module Configuration].
[MC-Configurator] starts.
- 4 Expand [SVC] of Sub CPU, and double-click [01 UNDEFINED].
- 5 Select the using Σ -X series of [Slave] dialog box, and click [OK].
- 6 Set "1" to the circuit number of [SVC].
- 7 Set "3" to the station address of the added Σ -X series.

8 Write the settings to the Sub CPU.

IMPORTANT

- To write the settings, select the [Save to flash after transferring to the controller] check box.
If the data is transferred without selecting the check box, the transferred data is deleted when restarting the External Device.

◆ Σ -X Series Setting

Set up communication settings with the DIP Switch (SW3) and the rotary switches (S1 and S2).
For details on communication settings, please refer to the manual of the External Device.

• DIP Switch (SW3) Setting

DIP Switch	Settings	Setup Description
1	Optional	Transmission byte size
2		
3	ON	Communication protocol: MECHATROLINK-III
4	OFF	Always OFF

• Rotary switches (S1 and S2) Setting

Rotary Switch	Settings	Setup Description
S1 (x16)	0	Station address
S2 (x1)	3	

◆ Notes

- Check with a network administrator about IP address. Do not set the duplicate IP address.

4 Setup Items

Set up the Display's communication settings in GP Pro-EX or in the Display's offline mode. The setting of each parameter must match that of the External Device.

 "3 Communication Settings" (page 29)

NOTE

- Set the Display's IP address in offline mode.

Cf. Maintenance/Troubleshooting Guide "Ethernet Settings"

4.1 Setup Items in GP-Pro EX

■ Communication Settings

To display the setup screen, from the [Project] menu, point to [System Settings] and select [Device/PLC].

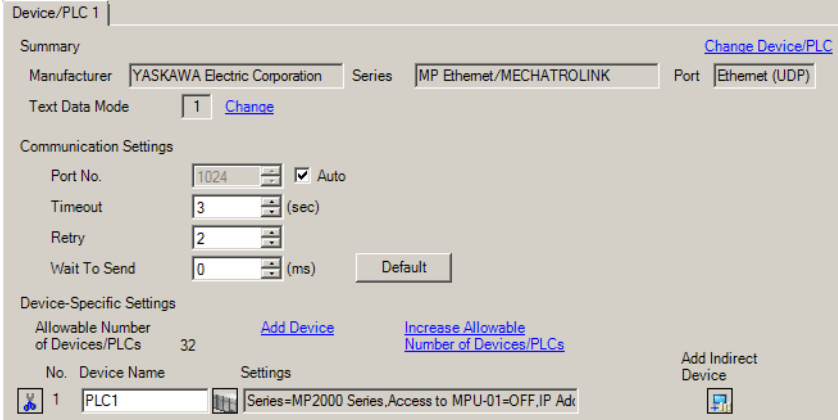

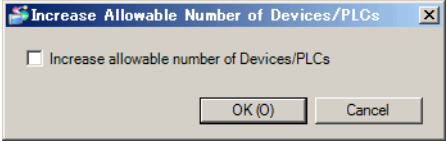
Setup Items	Setup Description
Port No.	Enter a port number of the External Device, using 1024 to 65535. Check into [Auto], and a port number is set automatically.
Timeout	Use an integer from 1 to 127 to enter the time (s) for which Display waits for the response from External Device.
Retry	In case of no response from the External Device, use an integer from 0 to 255 to enter how many times the Display retransmits the command.
Wait To Send	Use an integer from 0 to 255 to enter standby time (ms) for the Display from receiving packets to transmitting next commands.
Increase Allowable Number of Devices/PLCs	When clicked, the [Increase Allowable Number of Devices/PLCs] dialog box is displayed. When you check [Increase allowable number of Devices/PLCs], the settings for [Allowable Number of Devices/PLCs] can be extended to "64". 

NOTE

- Refer to the GP-Pro EX Reference Manual for Indirect Device.

Cf. GP-Pro EX Reference Manual "Changing the Device/PLC at Runtime (Indirect Device)"

◆ Device Setting

To display the [Individual Device Settings] dialog box, from [Device-Specific Settings] in the [Device/PLC] window, select the External Device and click [Settings] . To connect multiple External Devices, from [Device-Specific Settings] in the [Device/PLC] window, click [Add Device] to add another External Device.

MP2000 Series

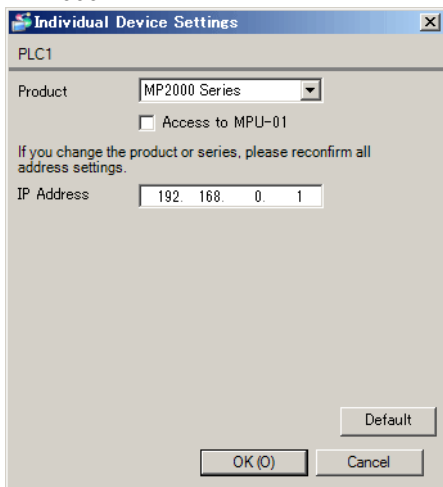

MP3000 Series

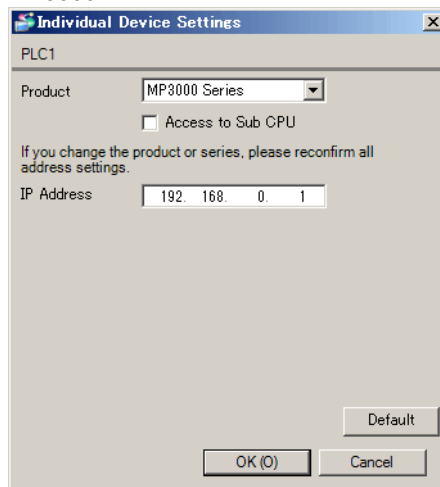

Setup Items	Setup Description
Product	Select the product name of the External Device.
Access to MPU-01 / Access to Sub CPU	Uncheck the check box when communicating with MP2000 series / MP3000 series.
IP Address	Set IP address of the External Device. <div style="border: 1px solid black; padding: 2px; display: inline-block;">NOTE</div> <ul style="list-style-type: none"> Check with a network administrator about IP address. Do not set the duplicate IP address.

MPU-01

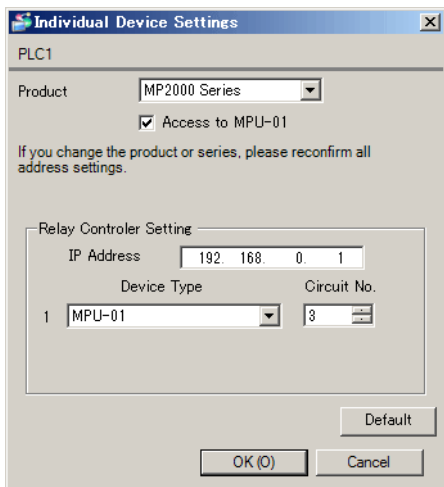

Sub CPU

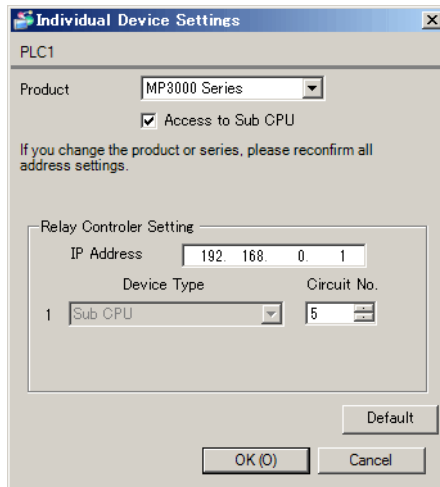

Setup Items	Setup Description
Product	Select the product name of the External Device.
Access to MPU-01 / Access to Sub CPU	Check the check box when using MPU-01 and Sub CPU. NOTE Uncheck the check box when using an Ethernet port on the Sub CPU.
IP Address	Set IP address of the relay device (MP series / Σ -7C (Controller section)). NOTE • Check with a network administrator about IP address. Do not set the duplicate IP address.
Device Type	Select a device type to be used for relay.
Circuit No.	Enter the circuit number, from 1 to 16.

Inverter Series

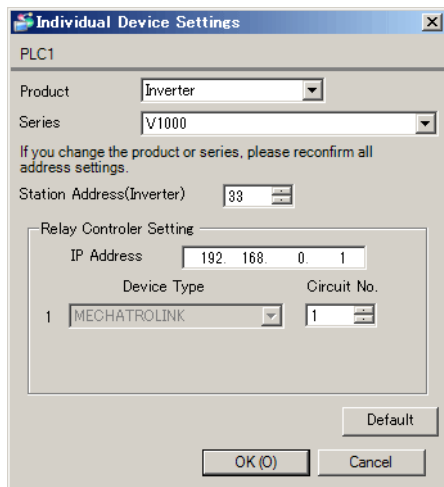

Servo Series

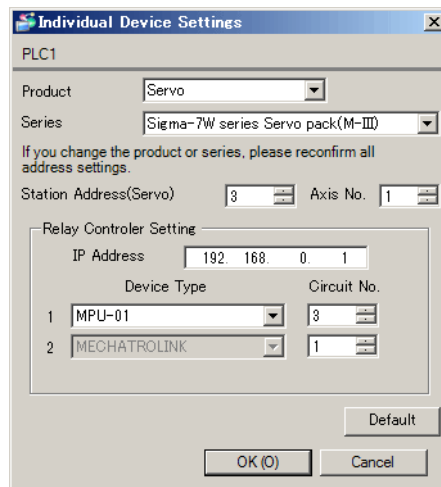

I/O

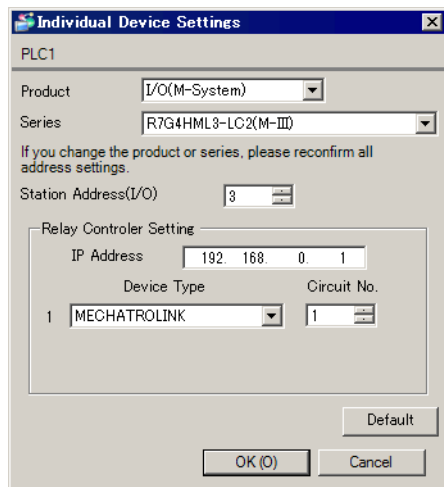

Stepping

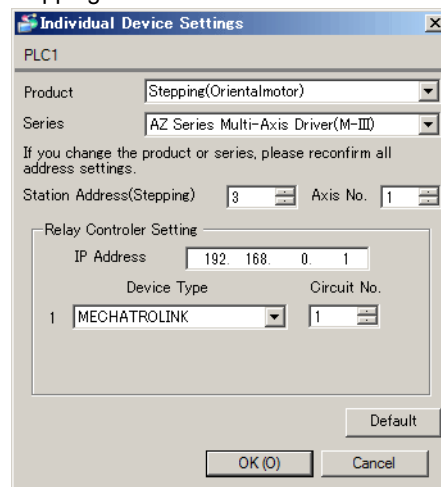

Setup Items	Setup Description
Product	Select the product name of the External Device.
Series	Select the series of the External Device.
Station Address	Inverter Series: Enter the station number, from 1 to 255. Servo Series: Enter the station number as follows. MECHATROLINK-II: "65 to 79" and "80 to 95" MECHATROLINK-III: "3 to 239" I/O: Enter the station address, from 3 to 239. Stepping: Enter the station address, from 3 to 239.
Axis No.	Σ -7W/ Σ -7C series: Enter the Axis number, from 1 to 2. AZ series: Enter the Axis number of stepping, from 1 to 255.
IP Address	Set IP address of the relay device (MP series / Σ -7C (Controller section)). NOTE • Check with a network administrator about IP address. Do not set the duplicate IP address.
Device Type	Select a device type to be used for relay.

Setup Items	Setup Description
Circuit No.	Enter the circuit number, from 1 to 16.

-
- IMPORTANT** • When communicating with the Servo Series, the first three octets in the subnet mask should be set to 255.
e.g.: 255.255.255.0
-

4.2 Setup Items in Offline Mode

NOTE

- Please refer to Maintenance/Troubleshooting Guide for more information on how to enter offline mode or about operation.
Cf. Maintenance/Troubleshooting Guide "Offline Mode"
- The number of the setup items to be displayed for 1 page in the offline mode depends on the Display in use. Please refer to the Reference manual for details.

◆ Communication Settings

To display the setting screen, touch [Device/PLC Settings] from [Peripheral Settings] in offline mode. Touch the External Device you want to set from the displayed list.

Comm.	Device			
MP Ethernet/MECHATROLINK			[UDP]	Page 1/1
Port No.	<input type="radio"/> Fixed <input checked="" type="radio"/> Auto	<input type="text" value="1024"/> ▼ ▲		
Timeout(s)	<input type="text" value="3"/> ▼ ▲			
Retry	<input type="text" value="2"/> ▼ ▲			
Wait To Send(ms)	<input type="text" value="0"/> ▼ ▲			
	Exit		Back	2014/11/19 17:11:29

Setup Items	Setup Description
Port No.	Enter a port number of the Display. Select either of "Fixed" "Auto". Enter a port number of the Display with "1024-65535", when select "Fixed". Assign automatically without affecting the input value, when select "Auto".
Timeout	Use an integer from 1 to 127 to enter the time (s) for which Display waits for the response from External Device.
Retry	In case of no response from the External Device, use an integer from 0 to 255 to enter how many times the Display retransmits the command.
Wait To Send	Use an integer from 0 to 255 to enter standby time (ms) for the Display from receiving packets to transmitting next commands.

■ Device Setting

To display the setting screen, touch [Device/PLC Settings] from [Peripheral Settings] in offline mode. Touch the External Device you want to set from the displayed list, and touch [Device].

Comm.	Device			
MP Ethernet/MECHATROLINK		[UDP]	Page 1/6	
Device/PLC Name	[PLC1] ▼			
Series	MP2000 Series			
IP Address	192 168 0 1			
				➔
Exit		Back		2014/11/19 17:11:39

Setup Items	Setup Description
Device/PLC Name	Select the External Device for device setting. Device name is a title of the External Device set with GP-Pro EX. (Initial value [PLC1])
Series	Display the series of the External Device.
IP Address	Set IP addresses used by the External Device or relay device (MP series / Σ -7C (Controller section)). <div style="border: 1px solid black; padding: 2px; display: inline-block; margin-bottom: 5px;">NOTE</div> <ul style="list-style-type: none"> • Check with a network administrator about IP address. Do not set the duplicate IP address.

- MP2000/MP3000 Series (Page 2 - 3)

Comm.	Device			
MP Ethernet/MECHATROLINK		[UDP]	Page 3/6	
Device/PLC Name		[PLC1]		
Product		MP3000 Series		
Access to Sub CPU		ON		
Device Type		Circuit No.		
1 Sub CPU		5		
		<input type="button" value="←"/> <input type="button" value="→"/>		
Exit		Back		2014/11/19 17:27:18

Setup Items	Setup Description
Device/PLC Name	Select the External Device for device setting. Device name is a title of the External Device set with GP-Pro EX. (Initial value [PLC1])
Product	Display the product to connect.
Access to MPU-01 / Access to Sub CPU	Display the setting state.
Device Type	Displays the device type to be used for the relay.
Circuit No.	Display the circuit number.

- Servo Series (Page 4)

Comm.	Device			
MP Ethernet/MECHATROLINK			[UDP]	Page 4/6
Device/PLC Name	[PLC1]			
Product	Servo			
Station Address	65			
Axis No.	----			
Device Type	Circuit No.			
1 MECHATROLINK-II	1			
2 ----	----			
3 ----	----			
			←	→
	Exit		Back	2014/11/19 17:16:23

Setup Items	Setup Description
Device/PLC Name	Select the External Device for device setting. Device name is a title of the External Device set with GP-Pro EX. (Initial value [PLC1])
Product	Display the product to connect.
Station Address	Display the station address.
Axis No.	Display the Axis number. Available with Σ -7W/ Σ -7C series only.
Device Type	Displays the device type to be used for the relay.
Circuit No.	Display the circuit number.

- Inverter Series / I/O / Stepping (Page 5 - 6)

Comm.	Device			
MP Ethernet/MECHATROLINK		[UDP]	Page 6/6	
Device/PLC Name		[PLC1]		
Product		I/O(M-System)		
Station Address		3		
Device Type		Circuit No.		
1	MECHATROLINK-III	1		
2	----	----		
3	----	----		
				←
Exit		Back		2015/07/13 14:15:34

Setup Items	Setup Description
Device/PLC Name	Select the External Device for device setting. Device name is a title of the External Device set with GP-Pro EX. (Initial value [PLC1])
Product	Display the product to connect.
Station Address	Display the station address.
Device Type	Displays the device type to be used for the relay.
Circuit No.	Display the circuit number.

5 Supported Devices

Range of supported device address is shown in the table below. Please note that the actually supported range of the devices varies depending on the External Device to be used. Please check the actual range in the manual of your External Device.

5.1 MP2000 Series / MPU-01

 This address can be specified as system data area.

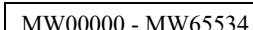
Device	Bit Address	Word Address	32 bits	Notes
System registers	SB000000 - SB08191F	SW00000 - SW08191		
Input registers	IB00000 - IBFFFFF	IW0000 - IWFFFF		*1
Output registers	OB00000 - OBFFFFF	OW0000 - OWFFFF		*1
Data registers	MB000000 - MB65534F	 MW00000 - MW65534		

*1 As for Input and Output registers, device 0x9000-0xFFFF cannot be written.

NOTE

- Please refer to the GP-Pro EX Reference Manual for system data area.
Cf. GP-Pro EX Reference Manual "LS Area (Direct Access Method Area)"
- Please refer to the precautions on manual notation for icons in the table.

 "Manual Symbols and Terminology"

5.2 MP3000 Series / Sub CPU

 This address can be specified as system data area.

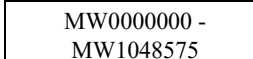
Device	Bit Address	Word Address	32 bits	Notes
System registers	SB000000 - SB65534F	SW00000 - SW65534		
Input registers	IB000000 - IB27FFFF	IW00000 - IW27FFF		*1
Output registers	OB000000 - OB27FFFF	OW00000 - OW27FFF		*1
Data registers	MB00000000 - MB1048575F	 MW0000000 - MW1048575		
G registers	GB000000000 - GB02097151F	GW000000000 - GW02097151		

*1 As for Input and Output registers, device 0x9000-0xFFFF cannot be written.



NOTE

- Please refer to the GP-Pro EX Reference Manual for system data area.
Cf. GP-Pro EX Reference Manual "LS Area (Direct Access Method Area)"
- Please refer to the precautions on manual notation for icons in the table.

 "Manual Symbols and Terminology"

5.3 Inverter Series

 This address can be specified as system data area.

Device	Bit Address	Word Address	32 bits	Notes
Bit registers * ¹	BR0000.0 - BR195C.F	-	-	* ²
Registers * ¹	-	0000 - 195C		 * ²

*¹ In the Inverter, bit registers and registers use the same device. Bit registers are used only for bit addresses.

The access method when specifying bits varies depending on the device.

Bit registers.....BR0000.0 - BR195C.F

Registers 

*² The available register numbers and available read/write operations differ depending on the External Device model. For further information, refer to the instruction manual for your External Device.

NOTE

- You can only set the Read Area Size for the system area in the External Device. Please refer to the GP-Pro EX Reference Manual for Read Area Size.
- Please refer to the GP-Pro EX Reference Manual for system data area.
Cf. GP-Pro EX Reference Manual "LS Area (Direct Access Method Area)"
- Please refer to the precautions on manual notation for icons in the table.
 "Manual Symbols and Terminology"

5.4 Σ -V Series

 This address can be specified as system data area.

Device	Bit Address	Word Address	32 bits	Notes
Normal Parameters Area	0000.0 - 0FFFF.F	0000 - 0FFF		*1 *2
Temporary Parameters Area	1000.0 - 1FFFF.F	1000 - 1FFF		*1 *2
Monitor Area	E000.0 - EFFFF.F	E000 - EFFF		*1 *2

*1 When you write to the bit address, the Display reads the entire word, sets the defined bit, then returns the new word value to the External Device. If the ladder program writes data to this word address during the bit write process, the resulting data may be incorrect.

*2 The following addresses are 32 bit parameters. Please use two words when reading or writing.

Normal Parameters Area

020AH / 020EH / 0210H / 0212H / 0282H / 051BH / 0520H / 0522H / 0524H / 0526H / 0531H /
 0804H / 0806H / 0808H / 0814H / 0819H / 0820H / 0822H / 0834H / 0836H / 0838H / 083AH /
 083CH / 083EH / 0840H / 0890H / 0892H / 0894H / 0896H / 0898H / 089AH / 089CH / 089EH /
 08A0H / 08A2H / 08A4H / 08A6H / 08A8H / 08AAH / 08ACH / 08AEH / 08B0H / 08B2H / 08B4H /
 08B6H / 08B8H / 08BAH / 08BCH / 08BEH / 0A02H / 0A04H / 0A06H / 0A08H / 0A0AH / 0A0CH /
 0A0EH / 0A10H / 0A12H / 0A14H / 0A16H / 0A18H / 0A42H / 0A44H / 0A46H / 0A48H / 0A4AH /
 0A4CH / 0A4EH / 0A50H / 0A52H / 0A82H / 0A84H / 0A86H / 0A88H / 0A8AH / 0A8CH / 0A8EH /
 0A90H / 0A92H / 0AC2H / 0AC4H / 0AC6H / 0AC8H / 0ACAH / 0ACCH / 0ACEH / 0B02H / 0B04H /
 0B06H / 0B08H / 0B0AH / 0B0CH / 0B0EH / 0B10H / 0B12H / 0B14H / 0B16H / 0B18H / 0B1AH /
 0B1CH / 0B1EH / 0B20H / 0B22H / 0B24H / 0B26H /

Temporary Parameters Area

120AH / 120EH / 1210H / 1212H / 1282H / 151BH / 1520H / 1522H / 1524H / 1526H / 1531H /
 1804H / 1806H / 1808H / 1814H / 1819H / 1820H / 1822H / 1834H / 1836H / 1838H / 183AH /
 183CH / 183EH / 1840H / 1890H / 1892H / 1894H / 1896H / 1898H / 189AH / 189CH / 189EH /
 18A0H / 18A2H / 18A4H / 18A6H / 18A8H / 18AAH / 18ACH / 18AEH / 18B0H / 18B2H / 18B4H /
 18B6H / 18B8H / 18BAH / 18BCH / 18BEH / 1A02H / 1A04H / 1A06H / 1A08H / 1A0AH / 1A0CH /
 1A0EH / 1A10H / 1A12H / 1A14H / 1A16H / 1A18H / 1A42H / 1A44H / 1A46H / 1A48H / 1A4AH /
 1A4CH / 1A4EH / 1A50H / 1A52H / 1A82H / 1A84H / 1A86H / 1A88H / 1A8AH / 1A8CH / 1A8EH /
 1A90H / 1A92H / 1AC2H / 1AC4H / 1AC6H / 1AC8H / 1ACAH / 1ACCH / 1ACEH / 1B02H / 1B04H /
 1B06H / 1B08H / 1B0AH / 1B0CH / 1B0EH / 1B10H / 1B12H / 1B14H / 1B16H / 1B18H / 1B1AH /
 1B1CH / 1B1EH / 1B20H / 1B22H / 1B24H / 1B26H /

Monitor Area

E003H / E009H / E00EH / E010H / E012H / E016H / E01BH / E084H / E52AH / E52CH / E52EH /
 E530H / E532H / E534H / E536H / E538H / E53AH / E53CH / E601H / E603H / E605H / E707H

NOTE

- You can only set the Read Area Size for the system area available to use in the External Device. Please refer to the GP-Pro EX Reference Manual for Read Area Size.
 - Please refer to the GP-Pro EX Reference Manual for system data area.
- Cf. GP-Pro EX Reference Manual "LS Area (Direct Access Method Area)"
- Please refer to the precautions on manual notation for icons in the table.

 "Manual Symbols and Terminology"

■ Normal Parameters Area

This area is used to map the External Device's user constant parameters. The register number is defined by adding the Pn number and the offset value. The normal parameters area offset value is 0000H.

For details on the Pn number and register mapping, please refer to the manual of the External Device.

Operation	Description
Read	Reads volatile memory such as RAM for values. Unable to read values from non-volatile memory such as EEPROM.
Write	Writes values to volatile memory such as RAM, and non-volatile memory such as EEPROM.

NOTE

- You cannot run consecutive reads from, or consecutive writes to, different register groups. Example: When consecutively reading from or writing to 07FFH to 0800H, the message "Data Consistency Error (33H)" or "Access Denied Error (31H)" is displayed.
- If you specify a nonexistent register number, the message "Access Denied Error (31H)," is displayed.

■ Temporary Parameters Area

This area is used to map the External Device's user constant parameters. The register number is defined by adding the Pn number and the offset value. The temporary parameters area offset value is 1000H.

For details on the Pn number and register mapping, please refer to the manual of the External Device.

Operation	Description
Read	Reads volatile memory such as RAM for values.
Write	Writes values to volatile memory such as RAM.

Since writing to Temporary Parameters Area is run in volatile memory (such as RAM), values are cleared when the External Device is turned OFF.

If there is an operation, such as servo tuning, that requires an extreme number of write operations to memory, running the operation in the Temporary Parameters Area generates the following advantages.

- You can increase the life of non-volatile memory.
- You can reduce processing time.

NOTE

- You cannot run consecutive reads from, or consecutive writes to, different register groups. Example: When consecutively reading from or writing to 17FFH to 1800H, the message "Data Consistency Error (33H)" or "Access Denied Error (31H)" is displayed.
- If you specify a nonexistent register number, the message "Access Denied Error (31H)," is displayed.

■ Monitor Area

This area is used to reference internal information (such as operating condition, alarm status, and various status flags) on the External Device. By referring to the value of a register number, you can check the status of the External Device. While the External Device is running, register values change constantly.

Register No.	Name	Unit	No. of Registers	Sign	Remarks
E000H	Motor Rotational/Translational Speed	Rotary: min^{-1}	1	S	Un000
		Linear: mm/s			
E001H	Reference Speed	Rotary: min^{-1}	1	S	Un001
		Linear: mm/s			
E002H	Internal Torque/Thrust Force Reference	%	1	S	Un002
E003H	Rotational Angle 1 (Number of Pulses from the Origin)	Pulse	2	U	Un003
E005H	Rotational Angle 2 (Angle from the Origin)	deg	1	U	Un004
E006H	Input Signal Monitor	-	1	-	Un005
E007H	Output Signal Monitor	-	1	-	Un006
E008H	Input Reference Pulse Speed	Rotary: min^{-1}	1	S	Un007
		Linear: mm/s			
E009H	Position Error Counter	Reference unit	2	S	Un008
E00BH	Accumulated Load Rate	%(10s cycle)	1	U	Un009
E00CH	Regenerative Load Rate	%(10s cycle)	1	U	Un00A
E00DH	Dynamic Break Consumption Power	%(10s cycle)	1	U	Un00B
E00EH	Input Reference Pulse Counter (32bit)	Pulse	2	S	Un00C
E010H	Feedback Pulse Counter (32bit)	Pulse	2	S	Un00D
E012H	Fully-closed Feedback Pulse Counter (32bit)	Pulse	2	S	Un00E
E016H	Total Operation Time	100ms	2	U	Un012
E018H	Upper Limit of Maximum Motor Speed	mm/s	1	U	Un010 (Available only in linear motor)
E019H	Upper Limit of Divided Pulse Output Setting	Pulse/Pitch	1	U	Un010 (Available only in linear motor)
E01AH	Magnetic Pole Sensor Information	-	1	-	Un011
E01BH	Feedback Pulse Counter	Reference unit	2	S	Un013
E01DH	Effective Gain Set Number	-	1	U	Un014
E01EH	Safety I/O Signal Monitor	-	1	-	Un015
E084H	Linear Scale Pitch	pm	2	U	Un084
E086H	Linear Scale Pitch Scaling Exponent	Power of Ten	1	S	Un085
E500H	Alarm History Alarm Code No. = 0	Code	1	U	Fn000-0

Register No.	Name	Unit	No. of Registers	Sign	Remarks
E501H	Alarm History Alarm Code No. = 1	Code	1	U	Fn000-1
E502H	Alarm History Alarm Code No. = 2	Code	1	U	Fn000-2
E503H	Alarm History Alarm Code No. = 3	Code	1	U	Fn000-3
E504H	Alarm History Alarm Code No. = 4	Code	1	U	Fn000-4
E505H	Alarm History Alarm Code No. = 5	Code	1	U	Fn000-5
E506H	Alarm History Alarm Code No. = 6	Code	1	U	Fn000-6
E507H	Alarm History Alarm Code No. = 7	Code	1	U	Fn000-7
E508H	Alarm History Alarm Code No. = 8	Code	1	U	Fn000-8
E509H	Alarm History Alarm Code No. = 9	Code	1	U	Fn000-9
E50AH	Current Alarm Information	Code	1	U	
E51BH	Servo Running Status	-	1	U	
E51CH	Control Mode Status	-	1	U	
E52AH	Alarm History Time Stamp No. = 0	100ms	2	U	
E52CH	Alarm History Time Stamp No. = 1	100ms	2	U	
E52EH	Alarm History Time Stamp No. = 2	100ms	2	U	
E530H	Alarm History Time Stamp No. = 3	100ms	2	U	
E532H	Alarm History Time Stamp No. = 4	100ms	2	U	
E534H	Alarm History Time Stamp No. = 5	100ms	2	U	
E536H	Alarm History Time Stamp No. = 6	100ms	2	U	
E538H	Alarm History Time Stamp No. = 7	100ms	2	U	
E53AH	Alarm History Time Stamp No. = 8	100ms	2	U	
E53CH	Alarm History Time Stamp No. = 9	100ms	2	U	

- Input Signal Monitor (E006H)

MECHATROLINK Interface Type

Bit	Status Signal	Logic	Un No.
0	SI0(CN1-13)	0 = Lo (Close) 1 = Hi (Open)	Un005
1	SI1(CN1-7)	0 = Lo (Close) 1 = Hi (Open)	
2	SI2(CN1-8)	0 = Lo (Close) 1 = Hi (Open)	
3	SI3(CN1-9)	0 = Lo (Close) 1 = Hi (Open)	
4	SI4(CN1-10)	0 = Lo (Close) 1 = Hi (Open)	
5	SI5(CN1-11)	0 = Lo (Close) 1 = Hi (Open)	
6	SI6(CN1-12)	0 = Lo (Close) 1 = Hi (Open)	
7	Reserved		

- Output Signal Monitor (E007H)

MECHATROLINK Interface Type

Bit	Status Signal	Logic	Un No.
0	ALM(CN1-3,4)	0 = Lo (Close) 1 = Hi (Open)	Un006
1	SO1(CN1-1,2)	0 = Lo (Close) 1 = Hi (Open)	
2	SO2(CN1-23,24)	0 = Lo (Close) 1 = Hi (Open)	
3	SO3(CN1-25,26)	0 = Lo (Close) 1 = Hi (Open)	
4	Reserved		
5	Reserved		
6	Reserved		
7	Reserved		

- Safety I/O Signal Monitor (E01EH)

Bit	Status Signal	Logic	Un No.
0	/HWBB1(CN8-3,4)	0 = Lo (Close) 1 = Hi (Open)	Un015
1	/HWBB2(CN8-5,6)	0 = Lo (Close) 1 = Hi (Open)	
2 to 7	Reserved		

NOTE

- /HWBB1 and /HWBB2 are valid only when the safety option card is not connected. When the safety option card is connected, they become indefinite.

- Servo Running Status (E51BH)

Reading	Description
0000H	Reserved (Initial State)
0001H	Alarm Occurred (A.***)
0002H	Hardwired Base Blocked (HWBB)
0003H	Forward / Reverse Run Prohibited (PTNT)
0004H	Forward Run Prohibited (P-OT)
0005H	Reverse Run Prohibited (N-OT)
0006H	Base Blocked (BB)
0007H	Base Enabled (RUN)
0008H	Magnetic Pole Detecting (PDET)

- Control Mode Status (E51CH)

Reading	Description
0000H	Speed Control Mode
0001H	Position Control Mode
0002H	Torque Control Mode

NOTE

- JOG Drive Mode, Origin Search Mode, and Internally Set Speed Control Mode become Speed control mode.
- Programmed JOG Drive Mode, Advanced Auto-Tuning Mode, and Easy FFT Mode become Position Control Mode.

5.5 Σ -7 Series

 This address can be specified as system data area.

Device	Bit Address	Word Address	32 bits	Notes
Normal Parameters Area	0000.0 - 0FFFF.F	0000 - 0FFF		*1 *2 *3
Temporary Parameters Area	1000.0 - 1FFFF.F	1000 - 1FFF		*1 *2 *3
Monitor Area	E000.0 - EFFFF.F	E000 - EFFF		*1 *3

*1 When you write to the bit address, the Display reads the entire word, sets the defined bit, then returns the new word value to the External Device. If the ladder program writes data to this word address during the bit write process, the resulting data may be incorrect.

*2 You cannot run block read or block write with the following addresses.

07FFH - 0800H

17FFH - 1800H

*3 The following addresses are 32 bit parameters. Please use two words when reading or writing.

Normal Parameters Area

020AH / 020EH / 0210H / 0212H / 0231H / 0282H / 051BH / 0520H / 0522H / 0524H / 0526H /
 0531H / 0804H / 0806H / 0808H / 0814H / 0819H / 0820H / 0822H / 0834H / 0836H / 0838H /
 083AH / 083CH / 083EH / 0840H / 0842H / 0844H / 0890H / 08A8H / 0A02H / 0A04H / 0A06H /
 0A08H / 0A0AH / 0A0CH / 0A0EH / 0A10H / 0A12H / 0A14H / 0A16H / 0A18H / 0A42H / 0A44H /
 0A46H / 0A48H / 0A4AH / 0A4CH / 0A4EH / 0A50H / 0A52H / 0A82H / 0A84H / 0A86H / 0A88H /
 0A8AH / 0A8CH / 0A8EH / 0A90H / 0A92H / 0AC2H / 0AC4H / 0AC6H / 0AC8H / 0ACAH / 0ACCH /
 0ACEH / 0B02H / 0B04H / 0B06H / 0B08H / 0B0AH / 0B0CH / 0B0EH / 0B10H / 0B12H / 0B14H /
 0B16H / 0B18H / 0B1AH / 0B1CH / 0B1EH / 0B20H / 0B22H / 0B24H / 0B26H /

Temporary Parameters Area

120AH / 120EH / 1210H / 1212H / 1282H / 151BH / 1520H / 1522H / 1524H / 1526H / 1531H /
 1804H / 1806H / 1808H / 1814H / 1819H / 1820H / 1822H / 1834H / 1836H / 1838H / 183AH /
 183CH / 183EH / 1840H / 1890H / 1892H / 1894H / 1896H / 1898H / 189AH / 189CH / 189EH /
 18A0H / 18A2H / 18A4H / 18A6H / 18A8H / 18AAH / 18ACH / 18AEH / 18B0H / 18B2H / 18B4H /
 18B6H / 18B8H / 18BAH / 18BCH / 18BEH / 1A02H / 1A04H / 1A06H / 1A08H / 1A0AH / 1A0CH /
 1A0EH / 1A10H / 1A12H / 1A14H / 1A16H / 1A18H / 1A42H / 1A44H / 1A46H / 1A48H / 1A4AH /
 1A4CH / 1A4EH / 1A50H / 1A52H / 1A82H / 1A84H / 1A86H / 1A88H / 1A8AH / 1A8CH / 1A8EH /
 1A90H / 1A92H / 1AC2H / 1AC4H / 1AC6H / 1AC8H / 1ACAH / 1ACCH / 1ACEH / 1B02H / 1B04H /
 1B06H / 1B08H / 1B0AH / 1B0CH / 1B0EH / 1B10H / 1B12H / 1B14H / 1B16H / 1B18H / 1B1AH /
 1B1CH / 1B1EH / 1B20H / 1B22H / 1B24H / 1B26H /

Monitor Area

E003H / E009H / E00EH / E010H / E012H / E016H / E01BH / E030H / E032H / E035H / E037H /
 E084H / E52AH / E52CH / E52EH / E530H / E532H / E534H / E536H / E538H / E53AH / E53CH /
 E548H / E54AH / E54CH / E54EH / E550H / E552H / E554H / E556H / EC00H / EC02H / EC04H /
 EC06H / EC08H / EC0AH / EC0CH / EC0EH / EC10H / EC12H / EC14H / EC16H

NOTE

- You can only set the Read Area Size for the system area available to use in the External Device. Please refer to the GP-Pro EX Reference Manual for Read Area Size.

- Please refer to the GP-Pro EX Reference Manual for system data area.

Cf. GP-Pro EX Reference Manual "LS Area (Direct Access Method Area)"

- Please refer to the precautions on manual notation for icons in the table.

 "Manual Symbols and Terminology"

■ Normal Parameters Area

This area is used to map the External Device's user constant parameters. The register number is defined by adding the Pn number and the offset value. The normal parameters area offset value is 0000H.

For details on the Pn number and register mapping, please refer to the manual of the External Device.

Operation	Description
Read	Reads volatile memory such as RAM for values. Unable to read values from non-volatile memory such as EEPROM.
Write	Writes values to volatile memory such as RAM, and non-volatile memory such as EEPROM.

NOTE

- You cannot run consecutive reads from, or consecutive writes to, different register groups. Example: When consecutively reading from or writing to 07FFH to 0800H, the message "Data Consistency Error (33H)" or "Access Denied Error (31H)" is displayed.
- If you specify a nonexistent register number, the message "Access Denied Error (31H)," is displayed.

■ Temporary Parameters Area

This area is used to map the External Device's user constant parameters. The register number is defined by adding the Pn number and the offset value. The temporary parameters area offset value is 1000H.

For details on the Pn number and register mapping, please refer to the manual of the External Device.

Operation	Description
Read	Reads volatile memory such as RAM for values.
Write	Writes values to volatile memory such as RAM.

Since writing to Temporary Parameters Area is run in volatile memory (such as RAM), values are cleared when the External Device is turned OFF.

If there is an operation, such as servo tuning, that requires an extreme number of write operations to memory, running the operation in the Temporary Parameters Area generates the following advantages.

- You can increase the life of non-volatile memory.
- You can reduce processing time.

NOTE

- You cannot run consecutive reads from, or consecutive writes to, different register groups. Example: When consecutively reading from or writing to 17FFH to 1800H, the message "Data Consistency Error (33H)" or "Access Denied Error (31H)" is displayed.
- If you specify a nonexistent register number, the message "Access Denied Error (31H)," is displayed.

■ Monitor Area

This area is used to reference internal information (such as operating condition, alarm status, and various status flags) on the External Device. By referring to the value of a register number, you can check the status of the External Device. While the External Device is running, register values change constantly.

Register No.	Name	Unit	No. of Registers	Sign	Remarks
E000H	Motor Rotational/Translational Speed	Rotary: min^{-1}	1	S	Un000 Average 64 ms
		Linear: mm/s			
E001H	Reference Speed	Rotary: min^{-1}	1	S	Un001
		Linear: mm/s			
E002H	Internal Torque/Thrust Force Reference	%	1	S	Un002
E003H	Rotational Angle 1 (Number of Pulses from the Origin)	Pulse	2	U	Un003
E005H	Rotational Angle 2 (Angle from the Origin)	deg	1	U	Un004
E006H	Input Signal Monitor	-	1	-	Un005
E007H	Output Signal Monitor	-	1	-	Un006
E008H	Input Reference Pulse Speed	Rotary: min^{-1}	1	S	Un007 Average 64 ms
		Linear: mm/s			
E009H	Position Error Counter	Reference unit	2	S	Un008
E00BH	Accumulated Load Rate	%(10s cycle)	1	U	Un009
E00CH	Regenerative Load Rate	%(10s cycle)	1	U	Un00A
E00DH	Dynamic Break Consumption Power	%(10s cycle)	1	U	Un00B
E00EH	Input Reference Pulse Counter (32bit)	Pulse	2	S	Un00C
E010H	Feedback Pulse Counter (32bit)	Pulse	2	S	Un00D
E012H	Fully-closed Feedback Pulse Counter (32bit)	Pulse	2	S	Un00E
E016H	Total Operation Time	100ms	2	U	Un012
E018H	Upper Limit of Maximum Motor Speed	mm/s	1	U	Un010 (Available only in linear motor)
E019H	Upper Limit of Divided Pulse Output Setting	Pulse/Pitch	1	U	Un010 (Available only in linear motor)
E01AH	Magnetic Pole Sensor Information	-	1	-	Un011
E01BH	Feedback Pulse Counter	Reference unit	2	S	Un013
E01DH	Effective Gain Set Number	-	1	U	Un014
E01EH	Safety I/O Signal Monitor	-	1	-	Un015
E02CH	Installation Environment monitor	%	1	S	Un025
E02DH	Servomotor Installation Environment Monitor	%	1	S	Un026

Register No.	Name	Unit	No. of Registers	Sign	Remarks
E02EH	Main Circuit DC Voltage	V	1	S	Un023
E030H	Backlash Compensation Amount	Reference unit	2	S	Un030
E032H	Backlash Compensation Setting Upper Limit	Reference unit	2	U	Un031
E034H	Power Consumption	[W]	1	S	Un032
E035H	Consumed Power	[Wh]	2	S	Un033
E037H	Cumulative Power Consumption (integral part)	[Wh]	2	S	Un034
E039H	Cumulative Power Consumption (decimal part)	[0.001Wh]	1	S	
E050H	Built-in Fan Remaining Life Ratio	0.01%	1	U	Un027
E051H	Capacitor Remaining Life Ratio	0.01%	1	U	Un028
E052H	Surge Prevention Circuit Remaining Life Ratio	0.01%	1	U	Un029
E053H	Dynamic Brake Circuit Remaining Life Ratio	0.01%	1	U	Un02A
E084H	Linear Scale Pitch	pm	2	U	Un084
E086H	Linear Scale Pitch Scaling Exponent	Power of Ten	1	S	Un085
E500H	Alarm History Alarm Code No. = 0	Code	1	U	Fn000-0
E501H	Alarm History Alarm Code No. = 1	Code	1	U	Fn000-1
E502H	Alarm History Alarm Code No. = 2	Code	1	U	Fn000-2
E503H	Alarm History Alarm Code No. = 3	Code	1	U	Fn000-3
E504H	Alarm History Alarm Code No. = 4	Code	1	U	Fn000-4
E505H	Alarm History Alarm Code No. = 5	Code	1	U	Fn000-5
E506H	Alarm History Alarm Code No. = 6	Code	1	U	Fn000-6
E507H	Alarm History Alarm Code No. = 7	Code	1	U	Fn000-7
E508H	Alarm History Alarm Code No. = 8	Code	1	U	Fn000-8
E509H	Alarm History Alarm Code No. = 9	Code	1	U	Fn000-9
E50AH	Current Alarm Information	Code	1	U	
E51BH	Servo Running Status	-	1	U	
E51CH	Control Mode Status	-	1	U	
E52AH	Alarm History Time Stamp No. = 0	100ms	2	U	
E52CH	Alarm History Time Stamp No. = 1	100ms	2	U	
E52EH	Alarm History Time Stamp No. = 2	100ms	2	U	
E530H	Alarm History Time Stamp No. = 3	100ms	2	U	
E532H	Alarm History Time Stamp No. = 4	100ms	2	U	
E534H	Alarm History Time Stamp No. = 5	100ms	2	U	

Register No.	Name	Unit	No. of Registers	Sign	Remarks
E536H	Alarm History Time Stamp No. = 6	100ms	2	U	
E538H	Alarm History Time Stamp No. = 7	100ms	2	U	
E53AH	Alarm History Time Stamp No. = 8	100ms	2	U	
E53CH	Alarm History Time Stamp No. = 9	100ms	2	U	
E53EH	Alarm History Counter 0	-	1	U	
E53FH	Alarm History Counter 1	-	1	U	
E540H	Alarm History Counter 2	-	1	U	
E541H	Alarm History Counter 3	-	1	U	
E542H	Alarm History Counter 4	-	1	U	
E543H	Alarm History Counter 5	-	1	U	
E544H	Alarm History Counter 6	-	1	U	
E545H	Alarm History Counter 7	-	1	U	
E546H	Alarm History Counter 8	-	1	U	
E547H	Alarm History Counter 9	-	1	U	
E548H	Alarm Trace Data Address 0	-	2	U	
E54AH	Alarm Trace Data Address 1	-	2	U	
E54CH	Alarm Trace Data Address 2	-	2	U	
E54EH	Alarm Trace Data Address 3	-	2	U	
E550H	Alarm Trace Data Address 4	-	2	U	
E552H	Alarm Trace Data Address 5	-	2	U	
E554H	Alarm Trace Data Address 6	-	2	U	
E556H	Alarm Trace Data Address 7	-	2	U	
EC00H	Feedback position (APOS)	Reference unit	2	S	
EC02H	Current FFE(CPOS)	Reference unit	2	S	
EC04H	Position deviation (PERR)	Reference unit	2	S	
EC06H	Target position in the reference coordinate system (TPOS)	Reference unit	2	S	
EC08H	Feedback latch position in the machine coordinate system1(LPOS1)	Reference unit	2	S	
EC0AH	Feedback latch position in the machine coordinate system2(LPOS2)	Reference unit	2	S	
EC0CH	Feedback latch position in the machine coordinate system3(LPOS3)	Reference unit	2	S	
EC0EH	Target Speed (TSPD)	Speed Reference unit	2	S	
EC10H	Feedback Speed (FSPD)	Speed Reference unit	2	S	

Register No.	Name	Unit	No. of Registers	Sign	Remarks
EC12H	Reference Speed (CSPD)	Speed Reference unit	2	S	
EC14H	Torque Limit(TRQ_LIM)	Torque Reference unit	2	U	
EC16H	Speed Limit(SPD_LIM)	Speed Reference unit	2	U	
EC18H	M-III Current Communications Phase	-	1	U	M-III only
EC19H	M-III Current Operating Command Code (RCMD)	-	1	U	M-III only (hexadecimal)
EC1AH	M-III Current Operating Subcommand Code (SUB_RCMD)	-	1	U	M-III only (hexadecimal)

- Input Signal Monitor (E006H)

Σ-7S series

Bit	Status Signal	Logic	Un No.
0	SI0	0 = Lo (Close) 1 = Hi (Open)	Un005
1	SI1	0 = Lo (Close) 1 = Hi (Open)	
2	SI2	0 = Lo (Close) 1 = Hi (Open)	
3	SI3	0 = Lo (Close) 1 = Hi (Open)	
4	SI4	0 = Lo (Close) 1 = Hi (Open)	
5	SI5	0 = Lo (Close) 1 = Hi (Open)	
6	SI6	0 = Lo (Close) 1 = Hi (Open)	
8 to 15	Reserved		

Σ -7W/ Σ -7C series

Bit	Status Signal	Logic	Un No.
0	SI0	0 = Lo (Close) 1 = Hi (Open)	Un005
1	SI1	0 = Lo (Close) 1 = Hi (Open)	
2	SI2	0 = Lo (Close) 1 = Hi (Open)	
3	SI3	0 = Lo (Close) 1 = Hi (Open)	
4	SI4	0 = Lo (Close) 1 = Hi (Open)	
5	SI5	0 = Lo (Close) 1 = Hi (Open)	
6	SI6	0 = Lo (Close) 1 = Hi (Open)	
7	SI7	0 = Lo (Close) 1 = Hi (Open)	
8	SI8	0 = Lo (Close) 1 = Hi (Open)	
9	SI9	0 = Lo (Close) 1 = Hi (Open)	
10	SI10	0 = Lo (Close) 1 = Hi (Open)	
11	SI11	0 = Lo (Close) 1 = Hi (Open)	
12 to 15	Reserved		

- Output Signal Monitor (E007H)

 Σ -7S series

Bit	Status Signal	Logic	Un No.
0	ALM	0 = Lo (Close) 1 = Hi (Open)	Un006
1	SO1	0 = Lo (Close) 1 = Hi (Open)	
2	SO2	0 = Lo (Close) 1 = Hi (Open)	
3	SO3	0 = Lo (Close) 1 = Hi (Open)	
7 to 15	Reserved		

Σ-7W/Σ-7C series

Bit	Status Signal	Logic	Un No.
0	ALM	0 = Lo (Close) 1 = Hi (Open)	Un006
1	SO1	0 = Lo (Close) 1 = Hi (Open)	
2	SO2	0 = Lo (Close) 1 = Hi (Open)	
3	SO3	0 = Lo (Close) 1 = Hi (Open)	
4	SO4	0 = Lo (Close) 1 = Hi (Open)	
5	SO5	0 = Lo (Close) 1 = Hi (Open)	
6	SO6	0 = Lo (Close) 1 = Hi (Open)	
7 to 15	Reserved		

- Safety I/O Signal Monitor (E01EH)

Bit	Status Signal	Logic	Un No.
0	/HWBB1	0 = Lo (Close) 1 = Hi (Open)	Un015
1	/HWBB2	0 = Lo (Close) 1 = Hi (Open)	
2 to 15	Reserved		

NOTE

- /HWBB1 and /HWBB2 are valid only when the safety option card is not connected. When the safety option card is connected, they become indefinite.

- Servo Running Status (E51BH)

Reading	Description
0000H	Reserved (Initial State)
0001H	Alarm Occurred (A.***)
0002H	Hardwired Base Blocked (HWBB)
0003H	Forward / Reverse Run Prohibited (PTNT)
0004H	Forward Run Prohibited (P-OT)
0005H	Reverse Run Prohibited (N-OT)
0006H	Base Blocked (BB)
0007H	Base Enabled (RUN)
0008H	Magnetic Pole Detecting (PDET)
0009H	Active Mode ON(ACT)
000AH	Force Stop ON(FSTP)
0103H	Safety Function Monitor ON & Forward / Reverse Run Prohibited (PTNT)
0104H	Safety Function Monitor ON & Forward Run Prohibited (P-OT)
0105H	Safety Function Monitor ON & Reverse Run Prohibited (N-OT)
0106H	Safety Function Monitor ON & Base Blocked (BB)
0107H	Safety Function Monitor ON & Base Enabled (RUN)
0108H	Safety Function Monitor ON & Magnetic Pole Detecting (PDET)
0109H	Safety Function Monitor ON & Active Mode ON(ACT)
010AH	Safety Function Monitor ON & Force Stop ON(FSTP)
0203H	Safety Function Safe ON & Forward / Reverse Run Prohibited (PTNT)
0204H	Safety Function Safe ON & Forward Run Prohibited (P-OT)
0205H	Safety Function Safe ON & Reverse Run Prohibited (N-OT)
0206H	Safety Function Safe ON & Base Blocked (BB)
0207H	Safety Function Safe ON & Base Enabled (RUN)
0208H	Safety Function Safe ON & Magnetic Pole Detecting (PDET)
0209H	Safety Function Safe ON & Active Mode ON(ACT)
020AH	Safety Function Safe ON & Force Stop ON(FSTP)

- Control Mode Status (E51CH)

Reading	Description
0000H	Speed Control Mode
0001H	Position Control Mode
0002H	Torque Control Mode

NOTE

- JOG Drive Mode, Origin Search Mode, and Internally Set Speed Control Mode become Speed control mode.
- Programmed JOG Drive Mode, Advanced Auto-Tuning Mode, and Easy FFT Mode become Position Control Mode.

5.6 Σ -X Series

 This address can be specified as system data area.

Device	Bit Address	Word Address	32 bits	Notes
Normal Parameters Area	0000.0 - 0FFF.F	0000 - 0FFF		*1 *2
Temporary Parameters Area	1000.0 - 1FFF.F	1000 - 1FFF		*1 *2
Monitor Area	E000.0 - EFFF.F	E000 - EFFF		*1
Alarm Trace Data Area	T0000.0 - TFFFF.7	T0000 - TFFFE		*1 *3





- *1 When you write to the bit address, the Display reads the entire word, sets the defined bit, then returns the new word value to the External Device. If the ladder program writes data to this word address during the bit write process, the resulting data may be incorrect.
- *2 You cannot run block read or block write with the following addresses.
07FFH - 0800H
17FFH - 1800H
- *3 For word access, only even addresses can be specified.

NOTE

- You can only set the Read Area Size for the system area available to use in the External Device. Please refer to the GP-Pro EX Reference Manual for Read Area Size.
- Please refer to the GP-Pro EX Reference Manual for system data area.
Cf. GP-Pro EX Reference Manual "LS Area (Direct Access Method Area)"
- Please refer to the precautions on manual notation for icons in the table.
 "Manual Symbols and Terminology"

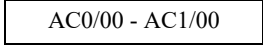
5.7 I/O(M-System) R7G4HML3-LC2(M-III) Series

 This address can be specified as system data area.

Device	Bit Address	Word Address	32 bits	Notes
Auto-Zero	-	AZ0/00 - AZ1/00	L/H	*1 *2
Zero point adjust	-	ZPA0/00 - ZPA1/00		*1 *2
Span point adjustment	-	SPA0/00 - SPA1/00		*1 *2
Average cycle	AC0/00.0 - AC1/00.F	 AC0/00 - AC1/00		 *2 *3
Monitor Output	-	MO0/00 - MO1/00		*1 *2
Monitor Output Release	-	MOR0/00 - MOR1/00		*1 *2
Offset Reset	-	OR0/00 - OR1/00		*1 *2
Virtual Memory Space	-	M0/0000-M0/019C		*4 *5
CR Filter Set	CR0/00.0	CR0/00		 *3
Voltage Set	V0/00.0	V0/00		 *3

- *1 Read disable
- *2 When a value is written, the corresponding processing is run.
The address consists of the address part and the channel part.

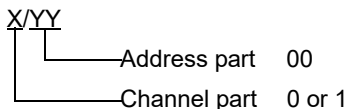

- *3 When you write to the bit address, the Display reads the entire word, sets the defined bit, then returns the new word value to the External Device. If the ladder program writes data to this word address during the bit write process, the resulting data may be incorrect.
- *4 Write disable
- *5 32-bit device

NOTE

- You can only set the Read Area Size for the system area available to use in the External Device. Please refer to the GP-Pro EX Reference Manual for Read Area Size.
- Please refer to the GP-Pro EX Reference Manual for system data area.
Cf. GP-Pro EX Reference Manual "LS Area (Direct Access Method Area)"
- Please refer to the precautions on manual notation for icons in the table.
 "Manual Symbols and Terminology"

5.8 I/O(M-System) R7G4HML3-STYVS1(M-III) Series

 This address can be specified as system data area.

Device	Bit Address	Word Address	32 bits	Notes
Angle Offset	-	AAZ00 - AAZ00	L / H	*1 *2
Angle Offset Read	-	AOR00 - AOR00		*3
Angle Span Setting	-	ARS00 - ARS00		
Virtual Memory Space	-	M0000-M019C		*3 *4
Linearization Count	LC00.0 - LC00.F	LC00 - LC00		*5
Linearization	L00.0 - L63.F	L00 - L63		*5 *6 *7
Output Bias	OB00.0 - OB00.F	OB00 - OB00		*5
Output Gain	OG00.0 - OG00.F	OG00 - OG00		*5

- *1 Read disable
- *2 The process runs when a value is written.
- *3 Write disable
- *4 32-bit device
- *5 When you write to the bit address, the Display reads the entire word, sets the defined bit, then returns the new word value to the External Device. If the ladder program writes data to this word address during the bit write process, the resulting data may be incorrect.
- *6 The Display can access a maximum 32 linearization devices. The device addresses corresponding to linearization devices are as follows.

Device Address	Linearization Device	Description
00	1.x	16-bit value
01	1.y	
02	2.x	
03	2.y	
:	:	
62	32.x	
63	32.y	



- *7 The Linearization Device reads and writes both X and Y as one set. And it always reads and writes from L0. To write to the specified address, the Display reads the corresponding word address range from L0 of the External Device, changes the word address value, then returns it to the External Device. While the Display is reading and then returning data to the External Device, write processes by the ladder program to the word address could cause the writing of incorrect data.
 Example:
 Write to L30(16.X), read L0(1.X) to L31(16.Y). Then, change the value of L30 only and return to the External Device.

NOTE

- You can only set the Read Area Size for the system area available to use in the External Device. Please refer to the GP-Pro EX Reference Manual for Read Area Size.
- Please refer to the GP-Pro EX Reference Manual for system data area.
Cf. GP-Pro EX Reference Manual "LS Area (Direct Access Method Area)"
- Please refer to the precautions on manual notation for icons in the table.
 "Manual Symbols and Terminology"

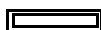
5.9 I/O(M-System) R7G4HML3-LC2A(M-III) Series

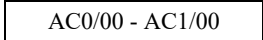
 This address can be specified as system data area.

Device	Bit Address	Word Address	32 bits	Notes
Auto-Zero	-	AZ0/00 - AZ1/00		*1 *2
Zero point adjust	-	ZPA0/00 - ZPA1/00		*1 *2
Span point adjustment	-	SPA0/00 - SPA1/00		*1 *2
Average cycle	AC0/00.0 - AC1/00.F	 AC0/00 - AC1/00		 *2 *3
Monitor Output	-	MO0/00 - MO1/00		*1 *2
Monitor Output Release	-	MOR0/00 - MOR1/00		*1 *2
Offset Reset	-	OR0/00 - OR1/00		*1 *2
Virtual Memory Space	-	M0/0000-M0/019C		*4 *5
CR Filter Set	CR0/00.0	CR0/00		 *3

*1 Read disable

*2 When a value is written, the corresponding processing is run.
The address consists of the address part and the channel part.

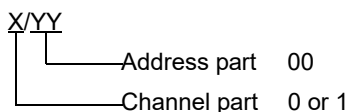

*3 When you write to the bit address, the Display reads the entire word, sets the defined bit, then returns the new word value to the External Device. If the ladder program writes data to this word address during the bit write process, the resulting data may be incorrect.

*4 Write disable



*5 32-bit device

NOTE

- You can only set the Read Area Size for the system area available to use in the External Device. Please refer to the GP-Pro EX Reference Manual for Read Area Size.
- Please refer to the GP-Pro EX Reference Manual for system data area.
Cf. GP-Pro EX Reference Manual "LS Area (Direct Access Method Area)"
- Please refer to the precautions on manual notation for icons in the table.
 "Manual Symbols and Terminology"

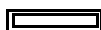
5.10 I/O(Azbil) K1G Series

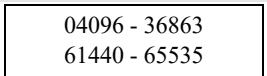
 This address can be specified as system data area.

Device	Bit Address	Word Address	32 bits	Notes
Data	04096,00 - 36863,15 61440,00 - 65535,15	 04096 - 36863 61440 - 65535	 L / H	*1 *2

- *1 When bits are written, the Display reads the corresponding word address from the External Device, sets particular bits of that word address to ON, and then returns the resulting address to the External Device. Note that the data may not be written correctly if you write to the word address using the External Device while the Display is reading data from, and writing data to, the External Device.
- *2 The Display uses the generic Modbus address format. Please refer to the following table for supported K1G series address types and address ranges.

K1G Series		Display
Address Types	Address Ranges	Address Ranges
Monitoring area	0x1000 - 0x1FFF	04096 - 08191
Setting area	0x2000 - 0x2FFF	08192 - 12287
Channel1 area	0x3000 - 0x3FFF	12288 - 16383
Channel2 area	0x4000 - 0x4FFF	16384 - 20479
Channel3 area	0x5000 - 0x5FFF	20480 - 24575
Channel4 area	0x6000 - 0x6FFF	24576 - 28671
Intensity area	0x7000 - 0x7FFF	28672 - 32767
Operation area	0x8000 - 0x8FFF	32768 - 36863
Special Function area	0xF000 - 0xFFFF	61440 - 65535

The External Device has 32 bit addresses. Read to or write from these 32 bit addresses in 32 bit units. For information about address length, please refer to the corresponding External Device manual.

NOTE

- You can only set the Read Area Size for the system area available to use in the External Device. Please refer to the GP-Pro EX Reference Manual for Read Area Size.
- Please refer to the GP-Pro EX Reference Manual for system data area.
Cf. GP-Pro EX Reference Manual "LS Area (Direct Access Method Area)"
- Please refer to the precautions on manual notation for icons in the table.
 "Manual Symbols and Terminology"

5.11 Stepping (ORIENTAL MOTOR) AZ Series

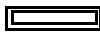
 This address can be specified as system data area.

Device	Bit Address	Word Address	32 bits	Notes
Parameter No.	0000.00 - 008F.31 1020.00 - 1978.31	0000 - 008F 1020 - 1978	-	*1 *2

*1 When bits are written, the Display reads the corresponding word address from the External Device, sets particular bits of that word address to ON, and then returns the resulting address to the External Device. Note that the data may not be written correctly if you write to the word address using the External Device while the Display is reading data from, and writing data to, the External Device.

*2 32-bit device

NOTE

- You can only set the Read Area Size for the system area available to use in the External Device. Please refer to the GP-Pro EX Reference Manual for Read Area Size.
- Please refer to the GP-Pro EX Reference Manual for system data area.
Cf. GP-Pro EX Reference Manual "LS Area (Direct Access Method Area)"
- Please refer to the precautions on manual notation for icons in the table.
 "Manual Symbols and Terminology"

6 Device Code and Address Code

Use device code and address code when you select "Device Type & Address" for the address type in data displays.

6.1 MP2000 Series / MPU-01

Device	Device Name	Device Code (HEX)	Address Code
System registers	SW/SB	0080	Word address
Input registers	IW/IB	0001	Word address
Output registers	OW/OB	0081	Word address
Data registers	MW/MB	0000	Word address

6.2 MP3000 Series / Sub CPU

Device	Device Name	Device Code (HEX)	Address Code
System registers	SW/SB	0080	Word address
Input registers	IW/IB	0001	Word address
Output registers	OW/OB	0081	Word address
Data registers	MW/MB	0000	Word address
G registers	GW/GB	0002	Word address

6.3 Inverter Series

Device	Device Name	Device Code (HEX)	Address Code
Bit registers	BR	0080	Address
Registers	-	0000	Address

6.4 Σ -V Series, Σ -7 Series

Device	Device Name	Device Code (HEX)	Address Code
Normal Parameters Area	0	0000	Word address
Temporary Parameters Area	1	0001	Word address
Monitor Area	E	0009	Word address

6.5 Σ -X Series

Device	Device Name	Device Code (HEX)	Address Code
Normal Parameters Area	0	0000	Word address
Temporary Parameters Area	1	0001	Word address
Monitor Area	E	0009	Word address
Alarm Trace Data Area	T	0022	Word address \div 2

6.6 I/O(M-System) R7G4HML3-LC2(M-III) Series

Device	Device Name	Device Code (HEX)	Address Code
Auto-Zero	AZ	0001	Channel number \times 0x10000 + Word address value
Zero point adjust	ZPA	0002	Channel number \times 0x10000 + Word address value
Span point adjustment	SPA	0003	Channel number \times 0x10000 + Word address value
Average cycle	AC	0000	Channel number \times 0x10000 + Word address value
Monitor Output	MO	0004	Channel number \times 0x10000 + Word address value
Monitor Output Release	MOR	0005	Channel number \times 0x10000 + Word address value
Offset Reset	OR	0006	Channel number \times 0x10000 + Word address value
Virtual Memory Space	M	0009	Word address
CR Filter Set	CR	0007	Word address
Voltage Set	V	0008	Word address

6.7 I/O(M-System) R7G4HML3-STYVS1(M-III) Series

Device	Device Name	Device Code (HEX)	Address Code
Angle Offset	AAZ	0001	Word address
Angle Span Setting	ARS	0002	Word address
Virtual Memory Space	M	0009	Word address
Linearization Count	LC	0000	Word address
Linearization	L	000A	Word address
Output Bias	OB	000C	Word address
Output Gain	OG	000D	Word address

6.8 I/O(M-System) R7G4HML3-LC2A(M-III) Series

Device	Device Name	Device Code (HEX)	Address Code
Auto-Zero	AZ	0001	Channel number × 0x10000 + Word address value
Zero point adjust	ZPA	0002	Channel number × 0x10000 + Word address value
Span point adjustment	SPA	0003	Channel number × 0x10000 + Word address value
Average cycle	AC	0000	Channel number × 0x10000 + Word address value
Monitor Output	MO	0004	Channel number × 0x10000 + Word address value
Monitor Output Release	MOR	0005	Channel number × 0x10000 + Word address value
Offset Reset	OR	0006	Channel number × 0x10000 + Word address value
Virtual Memory Space	M	0009	Word address
CR Filter Set	CR	0007	Word address

6.9 I/O(Azbil) K1G Series

Device	Device Name	Device Code (HEX)	Address Code
Data	-	0000	Word address

6.10 Stepping (ORIENTAL MOTOR) AZ Series

Device	Device Name	Device Code (HEX)	Address Code
Parameter No.	-	0000	Word address

7 Error Messages

Error messages are displayed on the screen of Display as follows: "No. : Device Name: Error Message (Error Occurrence Area)". Each description is shown below.

Item	Description
No.	Error No.
Device Name	Name of External Device where error occurs. Device name is a title of External Device set with GP-Pro EX.((Initial value [PLC1])
Error Message	Displays messages related to the error which occurs.
Error Occurrence Area	<p>Displays IP address or device address of External Device where error occurs, or error codes received from External Device.</p> <p>NOTE</p> <ul style="list-style-type: none"> • IP address is displayed such as "IP address (Decimal): MAC address (Hex)". • Device address is displayed such as "Address: Device address". • Received error codes are displayed such as "Decimal [Hex]".

Display Examples of Error Messages

"RHAA035: PLC1: Error has been responded for device write command (Error Code: 2 [02H])"

NOTE

- Please refer to the manual of External Device for more detail of received error codes.
- Please refer to "Display-related errors" of "Maintenance/Troubleshooting Guide" for a common error message to the driver.

7.1 MP Series

■ Error Codes Unique to External Device

Error code	Description
0x90	Transfer error.
0x92	Illegal parameter.
0x96	Register No. over.
0x9C	File is modified.
0x9D	Data access error.

■ Error Messages Unique to External Device

Message ID	Error Message	Description
RHxx128	"(Node Name):PLC is busy now(Error Code: [Hex])"	PLC is "Busy"
RHxx129	"(Node Name):Option module is not mounted(Error Code: [Hex])"	Option module not mount.
RHxx130	"(Node Name):Module is not ready(Error Code: [Hex])"	Module is not ready
RHxx131	"(Node Name):CPU is stopped(Error Code: [Hex])"	CPU is stopped
RHxx132	"(Node Name): Write protected(Error Code: [Hex])"	Write protected

7.2 Inverter Series

■ Error Codes Unique to External Device

Error code	Description
0x01	Function code error
0x02	Invalid register number error
0x03	Invalid quantity error
0x21	Date setting error
0x22	Write mode error
0x23	Main circuit undervoltage (UV) error during write
0x24	Write error during processing of constants

7.3 Servo Series

■ Error Codes Unique to External Device

Error code	Description
0x01	Function Code Error <ul style="list-style-type: none"> • Unsupported function code or sub function code.
0x02	Faulty Register Number <ul style="list-style-type: none"> • Accessing register number that is not registered.
0x03	Faulty Quantity <ul style="list-style-type: none"> • The number of read or write data for reading is not between one and the maximum quantity (as defined per model). • In write mode, the number of data in the message is not the specified quantity.
0x30	Faulty Register Number (High Level) <ul style="list-style-type: none"> • Accessing register number that is not registered.
0x31	Access Limit Error <ul style="list-style-type: none"> • Access to the specified register is not permitted.
0x32	Outside Setting Range Error <ul style="list-style-type: none"> • The write data value is outside the maximum and minimum limit.
0x33	Data Matching Error <ul style="list-style-type: none"> • Tried to access only a portion of registers in the multiple register unit. • Tried to access multiple registers that exceed the register group.
0x34	Condition Error <ul style="list-style-type: none"> • Command message content cannot be processed due to the condition defined by the register.
0x35	Process Conflict Error <ul style="list-style-type: none"> • Cannot be processed due to priority issues with other channels.
0x36	Axis number error (Σ -7W/ Σ -7C series only) <ul style="list-style-type: none"> • The extended address is using an axis number that is not available.

7.4 I/O(M-System)

■ Error Codes Unique to External Device

Error code	Description
0x01	Function Code Error <ul style="list-style-type: none"> Unsupported function code or sub function code in use.
0x03	Faulty Quantity <ul style="list-style-type: none"> The data count in read or write operations is outside the allowed range (1 to the maximum, as defined per model). In write mode, the data count in the message does not match the specified quantity.
0x04	Data Type Error <ul style="list-style-type: none"> Not supported by the defined mode or data type.
0x09	Process Conflict Error <ul style="list-style-type: none"> Cannot process due to priority issues with other channels.
0x81	Protocol ID Setting Error <ul style="list-style-type: none"> When running a vendor specific command, the protocol ID did not match the External Device.
0x82	Data Length Setting Error <ul style="list-style-type: none"> When running a vendor specific command, the data length setting for the vendor special area does not match the External Device.
0x83	Vendor Special Area Error <ul style="list-style-type: none"> When running a vendor specific command, a vendor special error occurred in the vendor special area.

- If the error code is 0x83, it is displayed together with the vendor special error code.

Example)

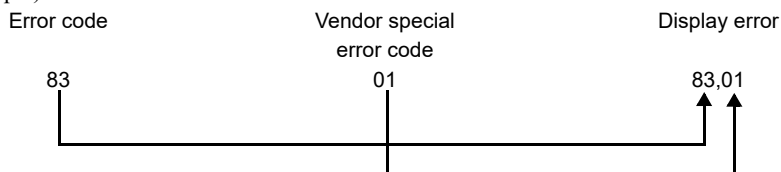

Vendor special error code

Error code	Description
0x01	Model code error <ul style="list-style-type: none"> The specified model code does not match the External Device.
0x02	Specified channel error <ul style="list-style-type: none"> External Device does not support the specified channel.
0x03	Setting command error <ul style="list-style-type: none"> External Device does not support the setting command.
0x04	Setting command data error <ul style="list-style-type: none"> Error in the setting command data.

■ Error Messages Unique to External Device

Message ID	Error Message	Description
RHxx134	(Node Name): Error has been responded for device read command (Error Code: [Hex,Hex])	The error message is displayed when the error has occurred in the read command.
RHxx135	(Node Name): Error has been responded for device write command (Error Code: [Hex,Hex])	The error message is displayed when the error has occurred in the write command.

7.5 I/O(Azbil) K1G Series

■ Error Codes Unique to External Device

Error code	Description
0x01	Function Code Error <ul style="list-style-type: none"> Unsupported function code or sub function code in use.
0x02	Memory Address Error <ul style="list-style-type: none"> Memory address you tried to access is not in the memory address range.
0x03	Faulty Quantity <ul style="list-style-type: none"> The data count in read or write operations is outside the allowed range (1 to the maximum, as defined per model).
0x04	Data Type Error <ul style="list-style-type: none"> Not supported by the defined mode or data type. Not supported by the protocol ID or device code.
0x81	Protocol ID Setting Error <ul style="list-style-type: none"> When running a vendor specific command, the protocol ID did not match the External Device.
0x82	Data Length Setting Error <ul style="list-style-type: none"> When running a vendor specific command, the data length setting for the vendor special area does not match the External Device.
0x83	Vendors Special Area Error <ul style="list-style-type: none"> When running a vendor specific command, a vendor special error occurred in the vendor special area.

- If the error code is 0x83, and the vendor special error code is 0x01, it is displayed as follows.

Example)

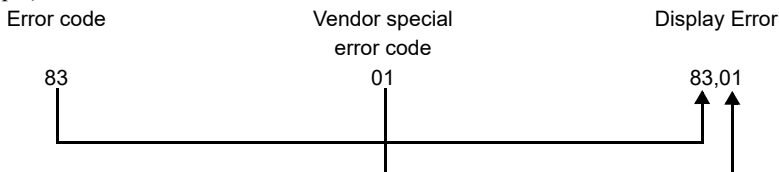

Vendor special error code

Error code	Description
0x01	Azbil protocol ID setting error <ul style="list-style-type: none"> The specified Azbil protocol ID is not supported by the External Device.

- If the error code is 0x83, and the vendor special error code is 0x81, it is displayed together with the Modbus error.

Example)

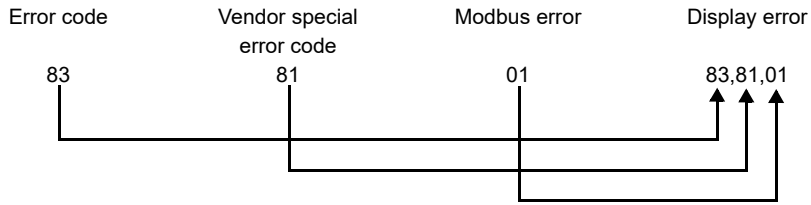

Vendor special error code

Error code	Description
0x81	MODBUS RTU abnormal response <ul style="list-style-type: none"> • Received a Modbus error. For more information, check the Modbus error code table.

Modbus error code

Error code	Description
0x01	Illegal function <ul style="list-style-type: none"> • Unsupported function code • Connected to unsupported External Device
0x02	Illegal data address <ul style="list-style-type: none"> • Data address error (area where access is prohibited)
0x03	Illegal data <ul style="list-style-type: none"> • Write out-of-range value • Equipment related, write-protected and read prohibited
0x13	Write mode error

■ Error Messages Unique to External Device

Message ID	Error Message	Description
RHxx134	(Node Name): Error has been responded for device read command (Error Code: [Hex,Hex])	The error message is displayed when the error has occurred in the read command.
RHxx135	(Node Name): Error has been responded for device write command (Error Code: [Hex,Hex])	The error message is displayed when the error has occurred in the write command.
RHxx136	(Node Name): Error has been responded for device read command (Error Code: [Hex,Hex, Hex])	The error message is displayed when the error has occurred in the read command.
RHxx137	(Node Name): Error has been responded for device write command (Error Code: [Hex,Hex, Hex])	The error message is displayed when the error has occurred in the write command.
RHxx138	(Node Name): Error has been responded for device read command (Error Code: (Decimal)[(Hex)] There are out of range devises)	The error message is displayed when the error has occurred in the read command.

Message ID	Error Message	Description
RHxx139	(Node Name): Error has been responded for device write command (Error Code: (Decimal)[(Hex)] There are out of range devises)	The error message is displayed when the error has occurred in the write command.

7.6 Stepping (ORIENTAL MOTOR) AZ Series

■ Error Codes Unique to External Device

Error code	Description
0x01	Function Code Error <ul style="list-style-type: none"> • Unsupported function code or sub function code in use.
0x02	Faulty Register Number <ul style="list-style-type: none"> • Accessing register number that is not registered.
0x03	Faulty Quantity <ul style="list-style-type: none"> • The number of read or write data for reading is not between one and the maximum quantity (as defined per model). • In write mode, the number of data in the message is not the specified quantity.
0x04	Data Type Error <ul style="list-style-type: none"> • Not supported by the defined mode or data type.
0x05	Access Limit Error <ul style="list-style-type: none"> • Access to the specified register is not permitted.
0x06	Outside Setting Range Error <ul style="list-style-type: none"> • The write data value is outside the maximum and minimum limit.
0x07	Data Matching Error <ul style="list-style-type: none"> • Tried to access only a portion of memory in the multiple register unit. • Tried to access multiple registers that exceed the register group.
0x08	Condition Error <ul style="list-style-type: none"> • Command message content cannot be processed due to the condition defined by the register.
0x09	Process Conflict Error <ul style="list-style-type: none"> • Cannot be processed due to priority issues with other channels.

