

Modicon TM3 guidebook for setting up connection to HMI

Revision History

Rev	Date	Description
Rev.00	2021-06-28	<ul style="list-style-type: none"> • New Creation
Rev.01	2021-08-03	<ul style="list-style-type: none"> • Add P.14 Supplied power • Add P.18 HMI line terminal
Rev.02	2021-09-16	<ul style="list-style-type: none"> • Add P.7, P38, P39, P54 Support Analog module for LT3000 • Add P.24 Download TM3BC IO Configurator download destination • Change of name P24-P35 TM3 Bus coupler -> TM3BC
Rev.03	2022-01-24	<ul style="list-style-type: none"> • P.24: Add cation software update • P.25~P28 Modified TM3 IO Configurator select language list
Rev.04	2022-04-21	<ul style="list-style-type: none"> • P.24: Add notes about software links
Rev.05	2022-08-04	<ul style="list-style-type: none"> • P.15 TM3DM24R Modified output number (6 -> 8) • P.16 Change cable type (integrated line terminator) • P.18 Delete cable type (Duplicate P.16 cable)
Rev.06	2023-07-18	<ul style="list-style-type: none"> • Added "Legal Information", "Safety Information", "About this book", "Cybersecurity". • Corrected information in "5.4 Analog input resolution" in P.18 • Corrected information in "8.4.4 Configuration of data range" in P.41 • Added STC6000 Series information (P.14, P.19, P.45-51, P.61-65)
Rev.07	2024-03-01	<ul style="list-style-type: none"> • Added Chapter 9 "When using TM3 modules as Remote I/O (EtherNet/IP)" • Added Chapter 10 "When using TM3 modules as local expansion I/O with STC6000" • Updated Chapter 11 "When using TM3 modules as local expansion I/O with LT3000 and STC6000 (replacing from LT3000)" • Added newly supported TM3 information in Chapter 12

Legal Information

The Pro-face brand and any trademarks of Schneider Electric SE and its subsidiaries referred to in this guide are the property of Schneider Electric SE or its subsidiaries. All other brands may be trademarks of their respective owners.

This guide and its content are protected under applicable copyright laws and furnished for informational use only. No part of this guide may be reproduced or transmitted in any form or by any means (electronic, mechanical, photocopying, recording, or otherwise), for any purpose, without the prior written permission of Schneider Electric.

Schneider Electric does not grant any right or license for commercial use of the guide or its content, except for a non-exclusive and personal license to consult it on an "as is" basis. Schneider Electric products and equipment should be installed, operated, serviced, and maintained only by qualified personnel.

As standards, specifications, and designs change from time to time, information contained in this guide may be subject to change without notice.

To the extent permitted by applicable law, no responsibility or liability is assumed by Schneider Electric and its subsidiaries for any errors or omissions in the informational content of this material or consequences arising out of or resulting from the use of the information contained herein.

As part of a group of responsible, inclusive companies, we are updating our communications that contain non-inclusive terminology. Until we complete this process, however, our content may still contain standardized industry terms that may be deemed inappropriate by our customers.

Table of contents

1	Safety Information	9
1.1	Important Information	9
2	About this book	10
2.1	Document Scope	10
2.2	Validity Note	10
2.3	Registered Trademarks	10
2.4	Related Documents	10
2.5	Product Related Information.....	10
3	Cybersecurity	14
3.1	Cybersecurity Guideline	14
4	Preface.....	15
4.1	Overview.....	15
4.1.1	When replacing from EX module to TM3 module, refer to Chapter 5 at first.	15
4.1.2	When using TM3 modules as remote I/O (CANopen connection), refer to Chapter 6-8	15
4.1.3	When using TM3 modules as remote I/O (EtherNet/IP connection), refer to Chapter 9	15
4.1.4	When using TM3 modules as local expansion I/O with STC6000, refer to Chapter 10	15
4.1.5	When using TM3 modules as local expansion I/O with LT3000 and STC6000 (when replacing from LT3000), refer to Chapter 11	15
4.1.6	For each TM3 module hardware specification, refer to Chapter 12	15
5	Precautions for replacing EX module with TM module.....	16
5.1	EX module and TM3 product model comparison	16
5.2	Sample duration time.....	17
5.3	New features installed on TM3.....	18
5.4	Analog input resolution	19
5.5	Replacement procedure	20
5.5.1	Workflow.....	20
5.5.2	Preparation.....	21
5.6	Other limitations.....	22
6	Specification comparison CANopen Unit.....	23
6.1	TM3BCCO Specification	23
6.1.1	Dimensions.....	23
6.2	Specification comparison between HTB unit and TM3BCCO Unit	24
6.2.1	Function difference	24
6.2.2	Configuration difference	24
6.3	Cable for TM3BCCO	25
6.3.1	Communication cable	25

6.3.2	CANopen line terminal.....	27
7	When using TM3 modules as Remote I/O (CANopen connection)	28
7.1	Connection	28
7.2	Connectable TM3 modules to TM3BCCO (CANopen)	28
7.3	Function difference between EXM and TM3 when connecting to CANopen	29
7.3.1	Specification Comparison of “EXM-AMI2HT” and “TM3AI2H / TM3AI2HG”	29
7.3.2	Specification Comparison of “EXM-ALM3LT” and “TM3TM3 / TM3TM3G”	29
7.3.3	Specification Comparison of “EXM-AMM3HT” and “TM3TM3 / TM3TM3G”	30
7.3.4	Specification Comparison of “EXM-AMO1HT” and “TM3AQ2 / TM3AQ2G”	30
7.3.5	Specification Comparison of “EXM-AMI4LT” and “TM3TI4 / TM3TI4G”	31
7.3.6	Specification Comparison of “EXM-AVO2HT” and “TM3AQ2 / TM3AQ2G”	31
7.3.7	Specification Comparison of “EXM-AMM6HT” and “TM3AM6 / TM3AM6G”	32
7.3.8	Specification Comparison of “EXM-ARI8LT” and “TM3TI4 / TM3TI4G”	32
8	TM3BC IO Configurator for CANopen connection.....	33
8.1	Overview.....	33
8.2	Download.....	33
8.3	Installation Instructions	33
8.3.1	About installation	33
8.3.2	Installation Procedure.....	34
8.4	TM3BC IO Configurator Operation Procedure	38
8.4.1	Main Screen	38
8.4.2	Create New Project	39
8.4.3	Add new devices	40
8.4.4	Configuration of data range	42
8.4.5	Data Export	43
8.4.6	Data Import.....	44
8.5	Limitations	45
9	When using TM3 modules as Remote I/O (EtherNet/IP).....	46
9.1	Overview.....	46
9.2	EIP Driver specifications	47
9.3	TM3BCEIP specifications.....	48
9.4	Connectable TM3 modules to TM3BCEIP (EtherNet/IP)	49
9.5	Number of connectable TM3 modules	49
9.6	Setup procedure for EtherNet/IP	50
9.6.1	Workflow.....	50
9.6.2	Install TM3BC IO Configurator	51
9.6.3	Configure TM3BCEIP	51
9.6.4	Download the configuration to TM3BCEIP	54

9.6.5	Import EDS file in GP-Pro EX.....	55
9.6.6	Setup the network configuration	58
9.6.7	Assign variables to Input/Output and Transfer to STC-6300TA.....	60
10	When using TM3 modules as local expansion I/O with STC6000	61
10.1	System configuration	61
10.1.1	Rear mounting	61
10.1.2	Extension mounting.....	61
10.2	Connectable TM3 Modules by local I/O expansion	63
10.3	Installation Procedure.....	64
10.3.1	When connecting to STC6000 (Rear mounting)	64
10.4	I/O Driver settings in GP-Pro EX.....	66
11	When using TM3 modules for local expansion I/O with LT3000 and STC6000 (when replacing from LT3000)	69
11.1	System configuration.....	69
11.2	Connectable TM3 Modules	69
11.3	Number of connectable modules on the rear of LT3000/STC6000	70
11.4	In case of connecting 3 units of TM3/EX modules with STC6000	71
11.5	Installation Procedure.....	72
11.5.1	When connecting to LT3000 (Rear Mounting)	72
11.5.2	When connecting to STC6000 (Rear Mounting)	73
11.6	I/O Driver settings in GP-Pro EX.....	75
11.7	AIO module function difference (when mount on the rear of LT3000/STC6000).....	78
11.7.1	Specification Comparison of “EXM-AMI2HT” and “TM3AI2H / TM3AI2HG”	78
11.7.2	Specification Comparison of “EXM-ALM3LT” and “TM3TM3 / TM3TM3G”	78
11.7.3	Specification Comparison of “EXM-AMM3HT” and “TM3TM3 /TM3TM3G “	78
11.7.4	Specification Comparison of “EXM-AMO1HT” and “TM3AQ2 / TM2AQ2G”	78
11.7.5	Specification Comparison of “EXM-AMI4LT” and “TM3TI4 / TM3TI4G”	78
11.7.6	Specification Comparison of “EXM-AVO2HT and “TM3AQ2 / TM3AQ2G”	79
11.7.7	Specification Comparison of “EXM-AMM6HT” and “TM3AM6 / TM3AM6G”	79
11.7.8	Specification Comparison of “EXM-ARI8LT” and “TM3TI4 / TM3TI4G”	79
11.8	DIO module comparison.....	80
11.8.1	Specification Comparison of EXM-DDI8T and TM3DI8.....	80
11.8.2	Specification Comparison of EXM-DDI16DT and TM3DI16	81
11.8.3	Specification Comparison of EXM-DRA8RT and TM3DQ8R	82
11.8.4	Specification Comparison of EXM-DDO8TT and TM3DQ8T.....	83
11.8.5	Specification Comparison of EXM-DDO8UT and TM3DQ8U.....	84
11.8.6	Specification Comparison of EXM-DDO16TK and TM3DQ16TK	85
11.8.7	Specification Comparison of EXM-DDO16UK and TM3DQ16UK	86

11.8.8	Specification Comparison of EXM-DMM8DRT and TM3DM8R	87
11.8.9	Specification Comparison of EXM-DMM24DRT and TM3DM24R	88
12	TM3 Module Specification	89
12.1	Overview.....	89
12.2	General Specification	90
12.2.1	Electrical specifications.....	90
12.2.2	Environmental specifications.....	93
12.2.3	TWDFCW** Cable.....	94
12.3	Digital Input Modules.....	96
12.3.1	TM3DI8 / TMDI8G.....	96
12.3.2	TM3DI8A.....	98
12.3.3	TM3DI16 / TM3DI16G.....	100
12.3.4	TM3DI16K.....	102
12.3.5	TM3DI32K.....	104
12.4	Digital Output Modules	106
12.4.1	TM3DQ8R / TM3DQ8RG	106
12.4.2	TM3DQ16R / TM3DQ16RG	109
12.4.3	TM3DQ8U / TM3DQ8UG	112
12.4.4	TM3DQ8T / TM3DQ8TG.....	114
12.4.5	TM3DQ16U / TM3DQ16UG	116
12.4.6	TM3DQ16UK	118
12.4.7	TM3DQ16T / TM3DQ16TG.....	120
12.4.8	TM3DQ16TK.....	122
12.4.9	TM3DQ32UK	124
12.4.10	TM3DQ32TK.....	126
12.5	Digital Input/Output Modules	128
12.5.1	TM3DM8R / TM3DM8RG.....	128
12.5.2	TM3DM24R / TM3DM24RG.....	132
12.6	Analog Input Modules.....	137
12.6.1	TM3AI2H / TM3AI2HG	137
12.6.2	TM3AI4 / TM3AI4G	140
12.6.3	TM3TI4 / TM3TI4G.....	143
12.6.4	TM3TI4D / TM3TI4DG	147
12.6.5	TM3AI8 / TM3AI8G	151
12.7	Analog Output Module.....	154
12.7.1	TM3AQ2 / TM3AQ2G.....	154
12.7.2	TM3AQ4 / TM3AQ4G.....	157
12.8	Analog Input/Output Modules.....	160

12.8.1 TM3TM3 / TM3TM3G..... 160

12.8.2 TM3AM6 /TM3AM6G 165

1 Safety Information

1.1 Important Information

Read these instructions carefully and look at the equipment to become familiar with the device before trying to install, operate, service, or maintain it. The following special messages may appear throughout this documentation or on the equipment to warn of potential hazards or to call attention to information that clarifies or simplifies a procedure.



The addition of this symbol to a "Danger" or "Warning" safety label indicates that an electrical hazard exists which will result in personal injury if the instructions are not followed.



This is the safety alert symbol. It is used to alert you to potential personal injury hazards. Obey all safety messages that follow this symbol to avoid possible injury or death.

DANGER

DANGER indicates a hazardous situation which, if not avoided, **will result in** death or serious injury.

WARNING

WARNING indicates a hazardous situation which, if not avoided, **could result in** death or serious injury.

CAUTION

CAUTION indicates a hazardous situation which, if not avoided, **could result in** minor or moderate injury.

NOTICE

NOTICE is used to address practices not related to physical injury.

PLEASE NOTE

Electrical equipment should be installed, operated, serviced, and maintained only by qualified personnel. No responsibility is assumed by Schneider Electric for any consequences arising out of the use of this material. A qualified person is one who has skills and knowledge related to the construction and operation of electrical equipment and its installation and has received safety training to recognize and avoid the hazards involved.

2 About this book

2.1 Document Scope

This guidebook describes how to use the Modicon TM3 I/O expansion module (hereinafter referred to as TM3) with HMI.

2.2 Validity Note

This documentation is valid for this product.

The technical characteristics of the device(s) described in the present manual also appear online at www.pro-face.com.

The characteristics that are described in the present document should be the same as those characteristics that appear online. In line with our policy of constant improvement, we may revise content over time to improve clarity and accuracy. If you see a difference between the document and online information, use the online information as your reference.

2.3 Registered Trademarks

Product names used in this manual may be the registered trademarks owned by the respective proprietors.

2.4 Related Documents

You can download the manuals related to this product, such as hardware manual for respective HMI, from our website. <https://www.proface.com/en/download/search>

2.5 Product Related Information

If the equipment is used in a manner not specified by the manufacturer, the protection provided by the equipment may be impaired.

⚠️⚠️ DANGER**HAZARD OF ELECTRIC SHOCK, EXPLOSION, OR ARC FLASH**

- Remove all power from the device before removing any covers or elements of the system, and prior to installing or removing any accessories, hardware, or cables.
- Unplug the power cable from both this product and the power supply prior to installing or removing the product.
- Always use a properly rated voltage sensing device to confirm power is off where and when indicated.
- Replace and secure all covers or elements of the system before applying power to this product.
- Use only the specified voltage when operating this product. This product is designed to use 24 Vdc. Always check whether your device is DC powered before applying power.
- When using this product in Class I, Division 2, Groups A, B, C, and D hazardous locations, install this product in an enclosure that prevents the operator from touching the back of this product without the use of tools.

Failure to follow these instructions will result in death or serious injury.

Critical alarm indicators and system functions require independent and redundant protection hardware and/or mechanical interlocks.

When you cycle power, wait at least 10 seconds after it has been turned off. If this product is restarted too quickly, it may not operate correctly.

In the event the screen cannot be properly read, for example, if the backlight is not functioning, it may be difficult or impossible to identify a function. Functions that may present a hazard if not immediately executed, such as a fuel shut-off, must be provided independently of this product. The machine's control system design must take into account the possibility of the backlight no longer functioning and the operator being unable to control the machine or making mistakes in the control of the machine.

⚠ WARNING
<p>LOSS OF CONTROL</p> <ul style="list-style-type: none"> • The designer of any control scheme must consider the potential failure modes of control paths and, for certain critical control functions, provide a means to achieve a safe state during and after a path failure. Examples of critical control functions are emergency stop and overtravel stop, power outage and restart. • Separate or redundant control paths must be provided for critical control functions. • System control paths may include communication links. Consideration must be given to the implications of unanticipated transmission delays or failures of the link. • Observe all accident prevention regulations and local safety guidelines. • Each implementation of this product must be individually and thoroughly tested for proper operation before being placed into service. • The machine control system design must take into account the possibility of the backlight no longer functioning and the operator being unable to control the machine, or making errors in the control of the machine. <p>Failure to follow these instructions can result in death, serious injury, or equipment damage.</p>

For additional information, refer to NEMA ICS 1.1 (latest edition), "Safety Guidelines for the Application, Installation, and Maintenance of Solid State Control" and to NEMA ICS 7.1 (latest edition), "Safety Standards for Construction and Guide for Selection, Installation and Operation of Adjustable-Speed Drive Systems" or their equivalent governing your particular location.

⚠ WARNING
<p>UNINTENDED EQUIPMENT OPERATION</p> <ul style="list-style-type: none"> • The application of this product requires expertise in the design and programming of control systems. Only persons with such expertise should be allowed to program, install, alter, and apply this product. • Follow all applicable safety standard, local regulations and directives. <p>Failure to follow these instructions can result in death, serious injury, or equipment damage.</p>

⚠ WARNING
<p>UNINTENDED EQUIPMENT OPERATION</p> <ul style="list-style-type: none"> • Do not use this product as the only means of control for critical system functions such as motor start/stop or power control. • Do not use this equipment as the only notification device for critical alarms, such as device overheating or overcurrent. • Use only the software provided with this product. If you use other software, please confirm the operation and safety before use. <p>Failure to follow these instructions can result in death, serious injury, or equipment damage.</p>

The following characteristics are specific to the LCD panel and are considered normal behavior:

- LCD screen may show unevenness in the brightness of certain images or may appear different when seen from outside the specified viewing angle. Extended shadows, or crosstalk may also appear on the sides of screen images.
- LCD screen pixels may contain black and white colored spots and color display may seem to have changed.
- When experiencing vibrations within a certain frequency range and vibration acceleration is above what is acceptable, the LCD screen may partially turn white. Once the vibration condition ends, the whitening of the screen is resolved.
- When the same image is displayed on the screen for a long period, an afterimage may appear when the image is changed.
- The panel brightness may decrease when used for a long time in an environment continuously filled with inert gas. To prevent deterioration of panel brightness, regularly ventilate the panel. For more information, please contact customer support.

<https://www.pro-face.com/trans/en/manual/1015.html>

▲ WARNING

SERIOUS EYE AND SKIN INJURY

The liquid in the LCD panel contains an irritant:

- Avoid direct skin contact with the liquid.
- Wear gloves when you handle a broken or leaking unit.
- Do not use sharp objects or tools in the vicinity of the LCD panel.
- Handle the LCD panel carefully to prevent puncture, bursting, or cracking of the panel material.
- If the panel is damaged and any liquid comes in contact with your skin, immediately rinse the area with running water for at least 15 minutes. If the liquid gets in your eyes, immediately rinse your eyes with running water for at least 15 minutes and consult a doctor.

Failure to follow these instructions can result in death, serious injury, or equipment damage.

NOTICE

REDUCTION OF SERVICE LIFE OF PANEL

Change the screen image periodically and try not to display the same image for a long period of time.

Failure to follow these instructions can result in equipment damage.

3 Cybersecurity

3.1 Cybersecurity Guideline

Use this product inside a secure industrial automation and control system. Total protection of components (equipment/devices), systems, organizations, and networks from cyber attack threats requires multi-layered cyber risk mitigation measures, early detection of incidents, and appropriate response and recovery plans when incidents occur. For more information about cybersecurity, refer to the Pro-face HMI/IPC Cybersecurity Guide.

https://www.proface.com/en/download/manual/cybersecurity_guide

▲ WARNING

POTENTIAL COMPROMISE OF SYSTEM AVAILABILITY, INTEGRITY, AND CONFIDENTIALITY

- Change default passwords at first use to help prevent unauthorized access to device settings, controls and information.
- Disable unused ports/services and default accounts, where possible, to minimize pathways for malicious attacks.
- Place networked devices behind multiple layers of cyber defenses (such as firewalls, network segmentation, and network intrusion detection and protection).
- Apply the latest updates and hotfixes to your Operating System and software.
- Use cybersecurity best practices (for example: least privilege, separation of duties) to help prevent unauthorized exposure, loss, modification of data and logs, interruption of services, or unintended operation.

Failure to follow these instructions can result in death, serious injury, or equipment damage.

4 Preface

4.1 Overview

This guidebook describes how to use the TM3 module with HMI. In addition, the replacement method, precautions, restrictions, etc. when replacing from EX module to TM3 module are described.

4.1.1 When replacing from EX module to TM3 module, refer to [Chapter 5](#) at first.

4.1.2 When using TM3 modules as remote I/O (CANopen connection), refer to [Chapter 6-8](#).

Note: Remote I/O (CANopen) for STC6000 Series is planned to be supported.

4.1.3 When using TM3 modules as remote I/O (EtherNet/IP connection), refer to [Chapter 9](#).

4.1.4 When using TM3 modules as local expansion I/O with STC6000, refer to [Chapter 10](#).

4.1.5 When using TM3 modules as local expansion I/O with LT3000 and STC6000 (when replacing from LT3000), refer to [Chapter 11](#).

4.1.6 For each TM3 module hardware specification, refer to [Chapter 12](#).

5 Precautions for replacing EX module with TM module

5.1 EX module and TM3 product model comparison

Type	EX Module *2	TM3 Module		
		Connector Type (Screw Type)	Connector Type (Spring Type)	Connector Type (HE10)
Input Module	EXM-DDI8DT	TM3DI8	TM3DI8G	-
	EXM-DDI16DT	TM3DI16	TM3DI16G	-
Output Module	EXM-DDO8TT	TM3DQ8T	TM3DQ8TG	-
	EXM-DDO8UT	TM3DQ8U	TM3DQ8UG	-
	EXM-DRA8RT	TM3DQ8R	TM3DQ8RG	-
	EXM-DRA16RT	TM3DQ16R	TM3DQ16RG	-
	EXM-DDO16TK	-	-	TM3DQ16TK
	EXM-DDO16UK	-	-	TM3DQ16UK
Input/Output Mixed Module	EXM-DMM8DRT	TM3DM8R	TM3DM8RG	-
	EXM-DMM24DRF	TM3DM24R	TM3DM24RG	-
Analog Module *1	EXM-AMI2HT	TM3AI2H	TM3AI2HG	-
	EXM-AMO1HT	TM3AQ2	TM3AQ2G	-
	EXM-AVO2HT			-
	EXM-AMI4LT	TM3TI4	TM3TI4G	-
	EXM-ARI8LT	TM3TI4 (x2)	TM3TI4G (x2)	-
	EXM-AMM6HT	TM3AM6	TM3AM6G	-
	EXM-AMM3HT	TM3TM3	TM3TM3G	-
	EXM-ALM3LT			-

*1 TM3 analog modules are supported by GP-Pro EX V4.09.350 or later version.

The TM3 modules other than the analog modules are supported by GP-Pro EX V4.09.250 or later.

*2 The connector type of EX modules is a screw type connector except for the following three models.

- EXM-DDO16TK : MIL Connector
- EXM-DDO16UK : MIL Connector
- EXM-DMM24DRF : Terminal block

5.2 Sample duration time

The sampling time differs between EX module and TM3 module.

Be careful when using TM3 module as a replacement from EM module.

Especially for models with a longer sampling interval than EX module, check the specifications before use.

EX module	TM3 Module	Detail
EXM-ALM3LT	TM3TM3	
Thermocouple: 20ms max. Temperature Probes: 20ms max. for revision of PV:03 RL:07 SV:1.2 40ms max. for revision of PV:04 RL:08 SV:2.0	10ms or 100ms	TM3 is little slower than EX Module. Can be set to 10ms by TM3BC IO configurator setting. *Please check the operation before actual operation.
EXM-AMM3HT	TM3TM3	
20ms max.	10ms or 100ms	TM3 is little slower than EX Module. Can be set to 10ms by TM3BC IO configurator setting. *Please check the operation before actual operation.
EXM-AMI2HT	TM3AI2H	
20ms max.	1ms	TM3 is faster than EX Module. It is not critical difference
EXM-AMI4LT	TM3TI4	
160ms	10ms or 100ms (Voltage/Current) 100ms (Thermocouple/RTD)	TM3 is faster than EX Module. It is not critical difference
EXM-AMM6HT	TM3AM6	
64ms max.	1ms or 10ms	TM3 is faster than EX Module. It is not critical difference
EXM-ARI8LT	TM3TI4	
320ms per channel	100ms	TM3 is faster than EX Module. It is not critical difference

5.3 New features installed on TM3

New features installed on TM3 are not currently supported. The functions supported by EX module are available.

Not available function	Notes
Expander Connection	This is a new function for connecting multiple TM3BCCO units. GP-Pro EX cannot be used.
Web Server Connection	This is a new function of TM3BCCO. GP-Pro EX cannot be used.
No support unit by HTB	The unsupported TM3 modules listed in this guidebook. GP-Pro EX cannot be used.
HTB Special I/O Function	Supported by HTB unit, not supported by TM3BCCO. GP-Pro EX cannot be used.
Error behavior Object	Supported by HTB unit, not supported by TM3BCCO. GP-Pro EX cannot be used.
Polarity setting object for 8bit DIO	Supported by HTB unit, not supported by TM3BCCO. GP-Pro EX cannot be used.
InterruptMask object of DIO	Supported by HTB unit, not supported by TM3BCCO. GP-Pro EX cannot be used.
Optional module Setting	This is a new function of TM3BCCO. GP-Pro EX cannot be used.
Functional Mode Setting	This is a new function of TM3BCCO. GP-Pro EX cannot be used.
Fallback output function	Supported by HTB unit, not supported by TM3BCCO. GP-Pro EX cannot be used.
DIN Latch Setting	This is a new function of TM3 digital input module. TM3BC IO Configurator has settings, but GP-Pro EX cannot be used.
DIN Filter Setting	This is a new function of TM3 digital input module. TM3BC IO Configurator has settings, but GP-Pro EX cannot be used.
AIN Filter Setting	This is a new function of TM3 analog input module. TM3BC IO Configurator has settings, but GP-Pro EX cannot be used.
F/W update function for each module	The function supported by the EX module, but each module of TM3 is not supported.

5.4 Analog input resolution

IMPORTANT: Please note the following when replacing EX module with TM3 module.

The data range when used with voltage and current differs depending on the difference in resolution between the EX analog module and the TM3 analog module. The applicable cases are shown below.

EXM	Configuration	Data Range	TM3	Configuration	Data Range
EXM-AMI2HT	Fixed	0 ... 4095	TM3-AI2H	Fixed	0 ... 65535 *1
	User Setting	-32768 ... 32767		User Setting	-32768 ... 32767
EXM-AMM3HT	Fixed	0 ... 4095	TM3-TM3	Fixed	0 ... 65535 *1
	User Setting	-32768 ... 32767		User Setting	-32768 ... 32767
EXM-AMI4LT	Fixed	0 ... 4095	TM3-TI4	Fixed	0 ... 65535 *1
	User Setting	-32768 ... 32767		User Setting	-32768 ... 32767

*1 Function difference items

The TM3 module can be used in the same way as the EX module by specifying the same data range as the EX module in the user settings. If [Fixed] is selected for the EX module setting in GP-Pro EX as shown below, specify the data range when setting the TM3 module.

Example :

GP-Pro EX EXM Driver configuration

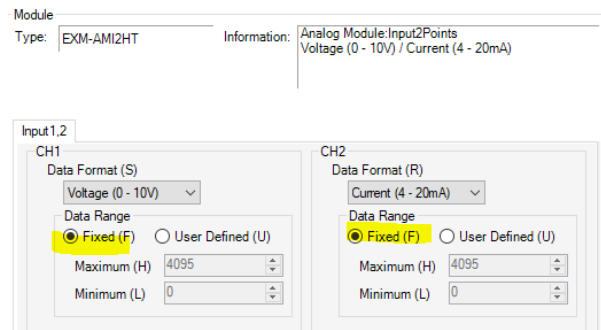

TM3 Setting

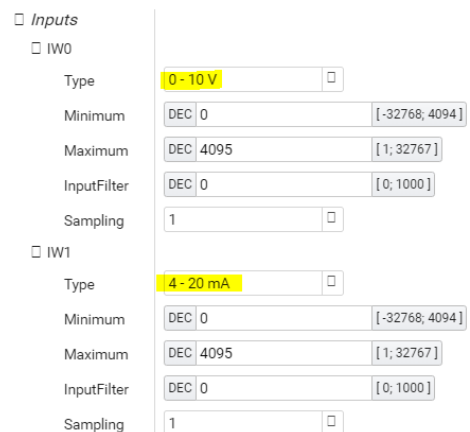

Refer to [Chapter 8. TM3BC IO Configurator](#) for TM3 module detail settings.

5.5 Replacement procedure

5.5.1 Workflow

For user with TM3 module as remote I/O (CANopen), refer to Chapter 6-8.

For user with TM3 module mounted on the rear of LT3000/STC6000, refer to Chapter 11.

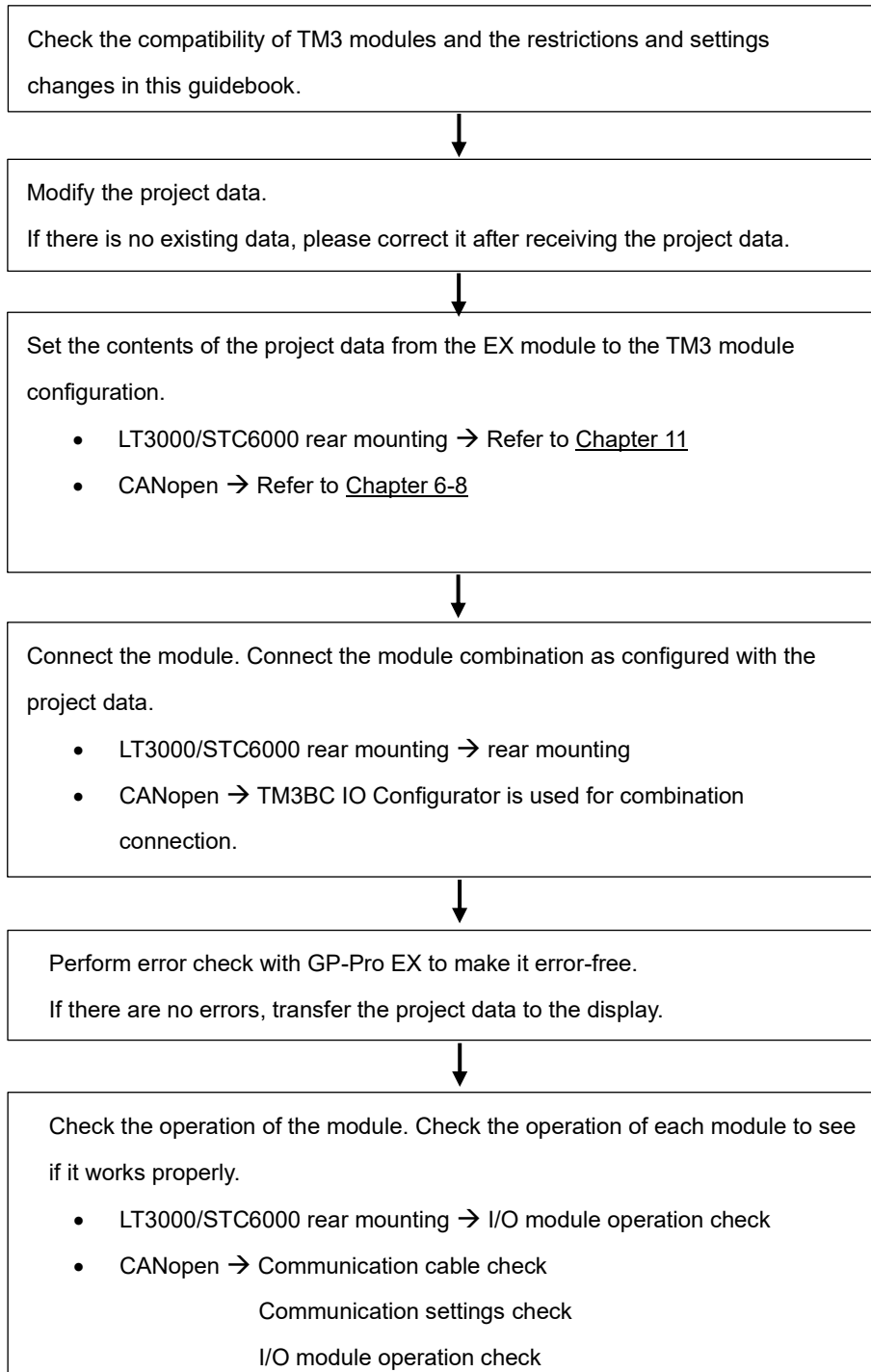

5.5.2 Preparation

The following environment is required to send and receive project data with GP-Pro EX.

Requirements for receiving screen data	PC in which GP-Pro EX Transfer Tool is installed. *1
	USB Transfer Cable (model: CA3-USBCB-01) * Possible to send/receive a screen via a CF card, a USB storage device or Ethernet.
Requirements for converting screen data	Software Environment Computer with the following software installed. *2 <ul style="list-style-type: none"> • GP-Pro EX Ver.4.09.250 or later (Ver.4.09.500 or later for STC6000) • TM3BC IO Configurator
	Hardware Environment <ul style="list-style-type: none"> • HMI • In case of CANopen Connection (LT4000 Series, SP5B10+SP5000 series) *3 <ul style="list-style-type: none"> ○ TM3BCCO, TM3 module ○ Communication cable <ul style="list-style-type: none"> ▪ TCSCCN4F3M1T, TCSCCN4F3M3T, Self-made ○ CANopen line terminator <ul style="list-style-type: none"> ▪ TCSCAR013M120, Self-made • In case of EtherNet/IP (STC6000 series) <ul style="list-style-type: none"> ○ TM3BCEIP, TM3 module ○ Communication cable (LAN) • In case of Mount on the rear of LT3000/STC6000 <ul style="list-style-type: none"> ○ LT3000/STC6000 series, TM3 module
	Supported transfer cables <ul style="list-style-type: none"> • USB transfer cable (P/N: PFXZUSCBMB2) • USB transfer cable (P/N: CA3-USBCB-01) • USB data-transfer cable (P/N: ZC9USCBMB1) • Commercial USB cable (USB Type A/mini-B/micro-B) *The supported transfer cable varies depending on the HMI. Refer to the hardware manual. * Possible to send/receive a screen via a SD card, a USB storage device or Ethernet.

*1 Please use the same version or later as or than that of the software used during creating screens.

If you don't know the version, we recommend you to use the newest version.

(http://www.pro-face.com/otasuke/download/freesoft/gpproex_transfer.htm)

For the newest version, you can download the transfer tool from our web site called [OtasukePro!]

*2 TM3 modules are supported by GP-Pro EX V4.09.250 or later.

*3 CANopen on STC6000 Series is planned to be supported.

5.6 Other limitations

The limitations are shown below.

	Description	Notes
1	Be sure to restart the HMI or TM3BCCO before changing the logic mode from STOP to RUN.	The logic change will be reflected after rebooting.
2	Be sure to restart the TM3BCCO after changing the polarity input settings.	The input polarity is reflected after restarting.

6 Specification comparison CANopen Unit

6.1 TM3BCCO Specification

6.1.1 Dimensions

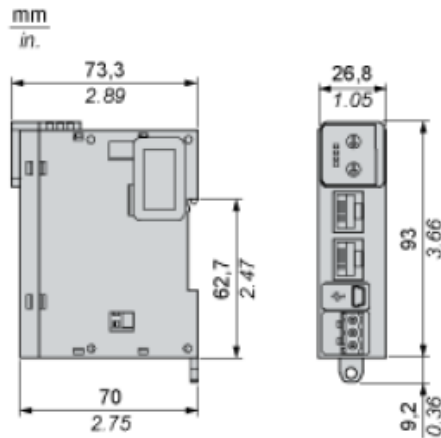

Item	Value
Communication port protocol	CANopen
Connector type	RJ45 2 CANopen daisy chain isolated / USB device port Mini-B
Transmission rate	20 kbit/s...1 Mbit/s
Topology	Daisy chain
Communication network type	CANopen
Communication service	CANopen slave device profile
Web services	Web server, USB
Current consumption	0.8 A at 24 V DC internal supply maximum 7 expansion modules
Local signaling	1 LED green/red for PWR (System Status) 1 LED green/red for RUN (Run) 1 LED green/red for ERR (Error) 1 LED green/red for I/O status
Connector insertion/removal durability	Over 100 times
Supplied power available for connected inputs and outputs modules. Current draw on 5 Vdc and 24 Vdc internal bus	600mA max.

6.2 Specification comparison between HTB unit and TM3BCCO Unit

6.2.1 Function difference

Refer to [New feature of TM3 module](#)

6.2.2 Configuration difference

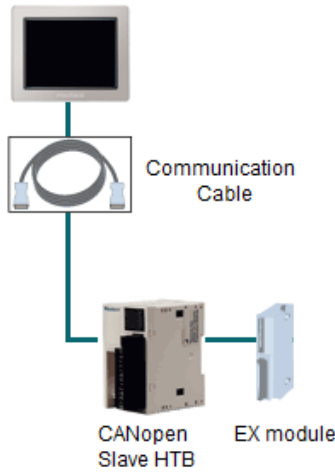
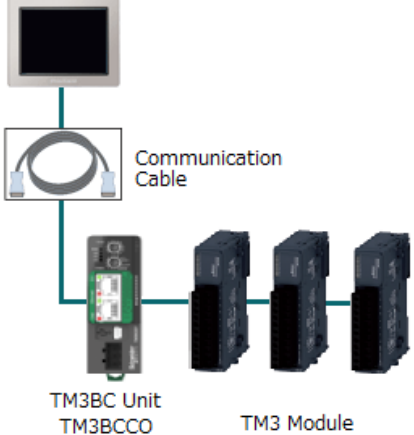
	HTB Unit	TM3BCCO (TM3 BC CANopen) + TM3 *1										
System												
Cable	Cable (User-self-made)	Cable (User-self-made)										
IO Unit	<p>HTB unit (HTB1C0DM9LP)</p> <p>Internal I/O</p> <table border="1" data-bbox="347 1211 911 1453"> <tr> <td>Input</td> <td>12-ch (DC24V, Sink/Source)</td> </tr> <tr> <td>Output</td> <td>6-ch (DC24V)</td> </tr> <tr> <td>Transistor Output</td> <td>2-ch (Source, DC24V)</td> </tr> </table>	Input	12-ch (DC24V, Sink/Source)	Output	6-ch (DC24V)	Transistor Output	2-ch (Source, DC24V)	<p>TM3BC CANopen (TM3BCCO)</p> <p>In the case of replacing the built-in I / O of HTB, it is necessary to prepare the following units.</p> <table border="1" data-bbox="959 1261 1528 1599"> <tr> <td>TM3DM24R (Input/ Relay Output)</td> <td>Input : 16-ch *2 (DC24V, Sink-Source) Output : 8-ch *2 (DC24V, Relay Output)</td> </tr> <tr> <td>TM3DQ8T (Transistor Output)</td> <td>Output : 8-ch *2 (Source, DC24V)</td> </tr> </table>	TM3DM24R (Input/ Relay Output)	Input : 16-ch *2 (DC24V, Sink-Source) Output : 8-ch *2 (DC24V, Relay Output)	TM3DQ8T (Transistor Output)	Output : 8-ch *2 (Source, DC24V)
Input	12-ch (DC24V, Sink/Source)											
Output	6-ch (DC24V)											
Transistor Output	2-ch (Source, DC24V)											
TM3DM24R (Input/ Relay Output)	Input : 16-ch *2 (DC24V, Sink-Source) Output : 8-ch *2 (DC24V, Relay Output)											
TM3DQ8T (Transistor Output)	Output : 8-ch *2 (Source, DC24V)											

*1 If you want to use the built-in IO unit, you need a new TM3 unit.

*2 Use I/O when using the HTB Unit, this is the number of I/O points that need to be added.

6.3 Cable for TM3BCCO

This chapter shows the pin assignment of the communication cable between TM3BCCO and the display.

* Since the connector shape is different from the conventional HTB unit, the conventional cable cannot be used.

6.3.1 Communication cable

VW3M3805R030 (CANopen cable - 1 x RJ45)

A line resistor is built into the D-sub 9pin side.

VW3M3805R030		
	Range of product	CANopen
	Electrical connection	2
	Product or component type	CANopen preassembled cable
	Connector type	1 RJ45 1 female SUB-D 9
	Cable length*1	3m
	Others	Switch to turn the terminating resistor on and off on the D-Sub 9 pin side.

*1 Cable Length 1m : VW3M3805R010

Pin Assignment

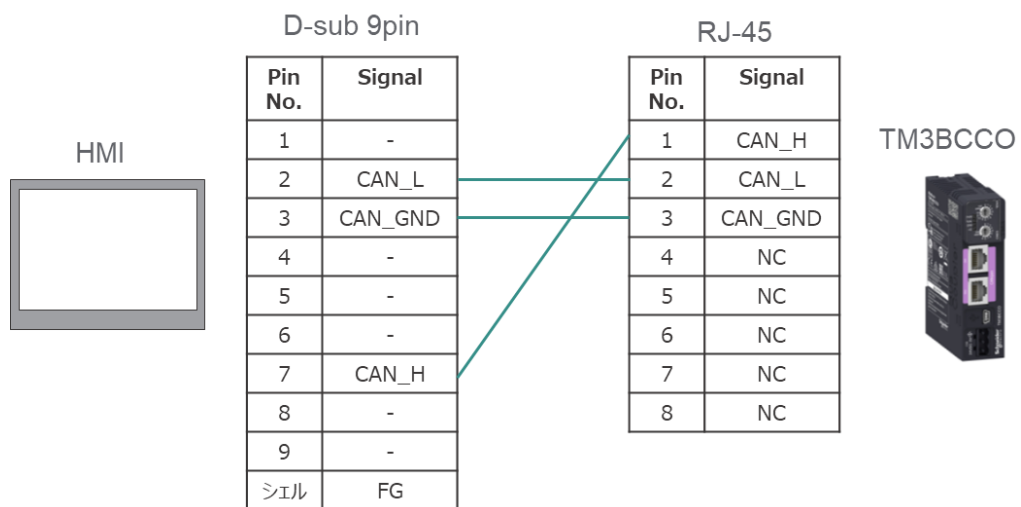

CANopen Interface (Display side)

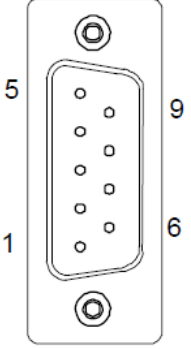
Pin connection		Signal	Description
 <p>(CANopen Master Unit Main)</p>	1	-	
	2	CAN_L	CAN_L BUS Line
	3	CAN_GND	CAN GRAND
	4	-	
	5	-	
	6	-	
	7	CAN_H	CAN_L BUS LINE
	8	-	
	9	-	
	Shell	FG	Frame Ground (SG Common)

RJ45 Interface (TM3BCCO side)

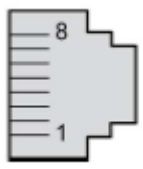
Pin connection		Signal	Description
	1	CAN_H	CAN_H bus line (High)
	2	CAN_L	CAN_L bus line (Low)
	3	CAN_GND	CAN 0 Vdc
	4	N.C.	No Connection
	5	N.C.	No Connection
	6	N.C.	No Connection
	7	N.C.	No Connection
	8	N.C.	No Connection

6.3.2 CANopen line terminal

The terminating resistor is required at both ends of each node.

TCSCAR013M120		
	Range of product	CANopen
	Electrical connection	1
	Product or component type	CANopen line terminator
	Connector type	RJ45

7 When using TM3 modules as Remote I/O (CANopen connection)

7.1 Connection

(Important Point)

- When using TM3 Module on CANopen, it is necessary to use CANopen communication unit (TM3BCCO).

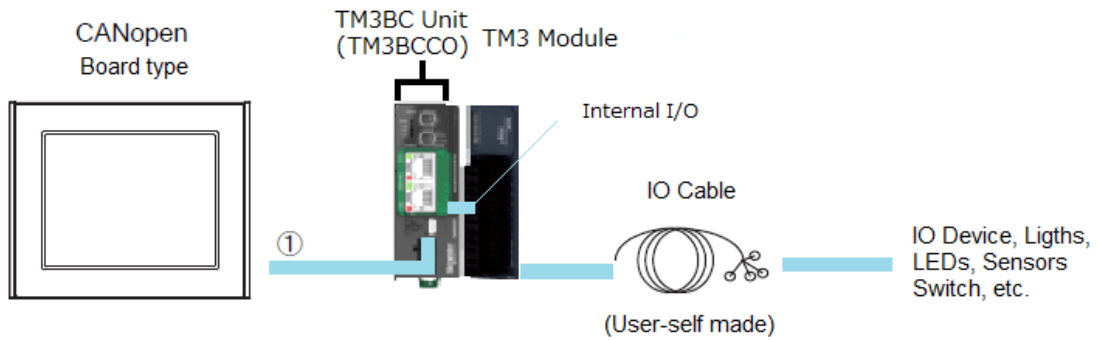

7.2 Connectable TM3 modules to TM3BCCO (CANopen)

Type	TM3		
	Screw type	Spring type	HE10
Input Module	TM3DI8	TM3DI8G	-
	TM3DI16	TM3DI16G	-
Output Module	TM3DQ8T	TM3DQ8TG	-
	TM3DQ8U	TM3DQ8UG	-
	TM3DQ8R	TM3DQ8RG	-
	-	-	TM3DQ16TK
	-	-	TM3DQ16UK
	TM3DQ16R	TM3DQ16RG	-
Input Output mixed Module	TM3DM8R	TM3DM8RG	-
	TM3DM24R	TM3DM24G	-
Analog Module	TM3AI2H	TM3AI2HG	-
	TM3AQ2	TM3AQ2G	-
	TM3TI4	TM3TI4G	-
	TM3AM6	TM3AM6G	-
	TM3TM3	TM3TM3G	-

7.3 Function difference between EXM and TM3 when connecting to CANopen

Only some of the TM3 functions can be used with GP-Pro EX. The restrictions are described per each module below.

7.3.1 Specification Comparison of “EXM-AMI2HT” and “TM3AI2H / TM3AI2HG”

Function	EXM-AMI2HT	TM3AI2H(Screw)/ TM3AI2HG (Spring)
Channel	Input 2-point	Input 2-point
Input Voltage	DC 0 to 10V	DC 0 to 10V, (DC -10 to 10V *1)
Input Current	DC 4 to 20mA	DC 4 to 20mA, (DC 0 to 20mA *1)

*1 This function and settings are not supported by GP-Pro EX.

7.3.2 Specification Comparison of “EXM-ALM3LT” and “TM3TM3 / TM3TM3G”

Function	EXM-ALM3LT	TM3TM3 (Screw) / TM3TM3G (Spring)
Channel	Input 2-point, Output 1-point	Input 2-point, Output 1-point
Input Voltage	-	DC 0 to 10V *2, (DC -10 to 10V *1)
Input Current	-	DC 4 to 20mA *2, (DC 0 to 20mA *1)
Thermocouple Type K	0 to 1300 °C	-200 to 1300 °C *2
Thermocouple Type J	0 to 1200 °C	-200 to 1000 °C *2
Thermocouple Type T	0 to 400 °C	-200 to 400 °C *2
Thermocouple Type R	-	0 to 1760 °C *1
Thermocouple Type S	-	0 to 1760 °C *1
Thermocouple Type B	-	0 to 1820 °C *1
Thermocouple Type N	-	200 to 1300 °C *1
Thermocouple Type E	-	-200 to 800 °C *1
Thermocouple Type C	-	0 to 2315 °C *1
Temperature PT100	-100 to 500 °C	-200 to 850 °C *2
Temperature PT1000	-	-200 to 600 °C *2
Temperature Ni100/Ni1000	-	-60 to 180 °C *2
Output Voltage	DC 0 to 10V	DC 0 to 10V, (DC -10 to 10V *1)
Output Current	DC 4 to 20mA	DC 4 to 20mA, (DC 0 to 20mA *1)

*1 This function and settings are not supported by GP-Pro EX.

*2 Function difference item

7.3.3 Specification Comparison of “EXM-AMM3HT” and “TM3TM3 / TM3TM3G”

Function	EXM-AMM3HT	TM3TM3 (Screw) / TM3TM3G (Spring)
Channel	Input 2-point, Output 1-point	Input 2-point, Output 1-point
Input Voltage	DC 0 to 10V	DC 0 to 10V, (DC -10 to 10V *1)
Input Current	DC 4 to 20mA	DC 4 to 20mA, (DC 0 to 20mA *1)
Thermocouple Type K	-	-200 to 1300 °C *1
Thermocouple Type J	-	-200 to 1000 °C *1
Thermocouple Type T	-	-200 to 400 °C *1
Thermocouple Type R	-	0 to 1760 °C *1
Thermocouple Type S	-	0 to 1760 °C *1
Thermocouple Type B	-	0 to 1820 °C *1
Thermocouple Type N	-	200 to 1300 °C *1
Thermocouple Type E	-	-200 to 800 °C *1
Thermocouple Type C	-	0 to 2315 °C *1
Temperature PT100	-	-200 to 850 °C *1
Temperature PT1000	-	-200 to 600 °C *1
Temperature Ni100/Ni1000	-	-60 to 180 °C *1
Output Voltage	DC 0 to 10V	DC 0 to 10V, (DC -10 to 10V *1)
Output Current	DC 4 to 20mA	DC 4 to 20mA, (DC 0 to 20mA *1)

*1 This function and settings are not supported by GP-Pro EX.

7.3.4 Specification Comparison of “EXM-AMO1HT” and “TM3AQ2 / TM3AQ2G”

Function	EXM-AMO1HT	TM3AQ2 (Screw) / TM3AQ2 (Spring)
Channel	Output 1-point	Output 2-point *2
Output Voltage	DC 0 to 10V	DC 0 to 10V, (DC -10 to 10V *1)
Output Current	DC 4 to 20mA	DC 4 to 20mA, (DC 0 to 20mA *1)

*1 This function and settings are not supported by GP-Pro EX.

*2 Function difference item

7.3.5 Specification Comparison of “EXM-AMI4LT” and “TM3TI4 / TM3TI4G”

Function	EXM-AMI4LT	TM3TI4 (Screw) / TM3TI4G (Spring)
Channel	Input 4-point	Input 4-point
Input Voltage	DC 0 to 10V	DC 0 to 10V, (DC -10 to 10V *1)
Input Current	DC 4 to 20mA	DC 4 to 20mA, (DC 0 to 20mA *1)
Thermocouple Type K	-	-200 to 1300 °C *1
Thermocouple Type J	-	-200 to 1000 °C *1
Thermocouple Type T	-	-200 to 400 °C *1
Thermocouple Type R	-	0 to 1760 °C *1
Thermocouple Type S	-	0 to 1760 °C *1
Thermocouple Type B	-	0 to 1820 °C *1
Thermocouple Type N	-	200 to 1300 °C *1
Thermocouple Type E	-	-200 to 800 °C *1
Thermocouple Type C	-	0 to 2315 °C *1
Temperature PT100	-200 to 600 °C	-200 to 850 °C *2
Temperature PT1000	-200 to 600 °C	-200 to 600 °C
Temperature Ni100/Ni1000	-50 to 150 °C	-60 to 180 °C *2

*1 This function and settings are not supported by GP-Pro EX.

*2 Function difference item

7.3.6 Specification Comparison of “EXM-AVO2HT” and “TM3AQ2 / TM3AQ2G”

Function	EXM-AVO2HT	TM3AQ2 (Screw) / TM3AQ2G (Spring)
Channel	Output 2-point	Output 2-point
Output Voltage	DC -10 to 10V	DC -10 to 10V, (DC 0 to 10V *1)
Output Current	-	DC 4 to 20mA *2, (DC 0 to 20mA *1)

*1 This function and settings are not supported by GP-Pro EX.

*2 Function difference item

7.3.7 Specification Comparison of “EXM-AMM6HT” and “TM3AM6 / TM3AM6G”

Function	EXM-AMM6HT	TM3AM6(Screw) / TM3AM6G (Spring)
Channel	Input 4-point, Output 2-point	Input 4-point, Output 2-point
Input Voltage	DC 0 to 10V	DC 0 to 10V, (DC -10 to 10V *1)
Input Current	DC 4 to 20mA	DC 4 to 20mA, (DC 0 to 20mA *1)
Output Voltage	DC 0 to 10V	DC 0 to 10V, (DC -10 to 10V *1)
Output Current	DC 4 to 20mA	DC 4 to 20mA, (DC 0 to 20mA *1)

*1 This function and settings are not supported by GP-Pro EX.

7.3.8 Specification Comparison of “EXM-ARI8LT” and “TM3TI4 / TM3TI4G”

Function	EXM-ARI8LT	TM3TI4x2 (Screw)/ TM3TI4Gx2 (Spring)
Channel	Input 8-point	Input 4-point *2 *3
Input Voltage	-	DC 0 to 10V *2, (DC -10 to 10V *1)
Input Current	-	DC 4 to 20mA *2, (DC 0 to 20mA *1)
Thermocouple Type K	-	-200 to 1300 °C *1
Thermocouple Type J	-	-200 to 1000 °C *1
Thermocouple Type T	-	-200 to 400 °C *1
Thermocouple Type R	-	0 to 1760 °C *1
Thermocouple Type S	-	0 to 1760 °C *1
Thermocouple Type B	-	0 to 1820 °C *1
Thermocouple Type N	-	200 to 1300 °C *1
Thermocouple Type E	-	-200 to 800 °C *1
Thermocouple Type C	-	0 to 2315 °C *1
Temperature PT100	-200 to 600 °C	-200 to 850 °C *2
Temperature PT1000	-50 to 200 °C	-200 to 600 °C *2
Temperature Ni100/Ni1000	-50 to 150 °C	-60 to 180 °C *2

*1 This function and settings are not supported by GP-Pro EX.

*2 Function difference item

*3 Two TM3TI4 units are required when using 5 channel or more

8 TM3BC IO Configurator for CANopen connection

8.1 Overview

The TM3BC IO Configurator software allows you to generate configuration files for TM3BC. This can be done offline, that is, the PC running the tool does not need to be physically connected to the bus coupler.

8.2 Download

Latest TM3BC IO Configurator can be downloaded from the following URL.

https://www.se.com/ww/en/download/document/TM3BC_IO_Configurator/

Note: Software updates will be made accordingly. Check the URL above for the latest version.

And the link destination may differ depending on the update of the Web Site. In that case, please search with [TM3BC IO Configurator].

8.3 Installation Instructions

8.3.1 About installation

- User Rights: you must have the administrator privileges on the workstation to install the TM3BC IO Configurator.

NOTE: TM3BC IO Configurator is always installed so that it is available for all the users of the workstation.

- The default destination directory of the TM3BC IO Configurator software installation is set as follows:
Windows OS (32bit) C:\Program Files\Schneider Electric\TM3BC IO Configurator\
Windows OS (64bit) C:\Program Files(x86)\Schneider Electric\TM3BC IO Configurator\



8.3.2 Installation Procedure

*The procedure is an image of version 1.1.9.1. If the version is different, the procedure image may be different.

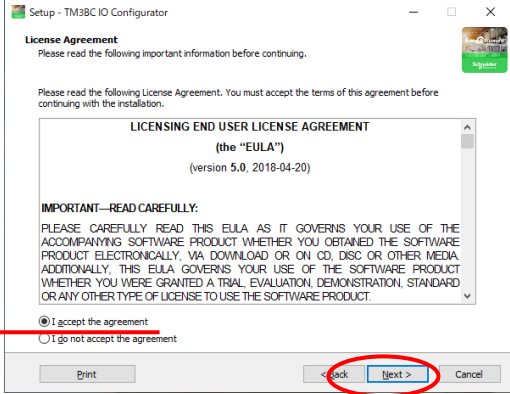
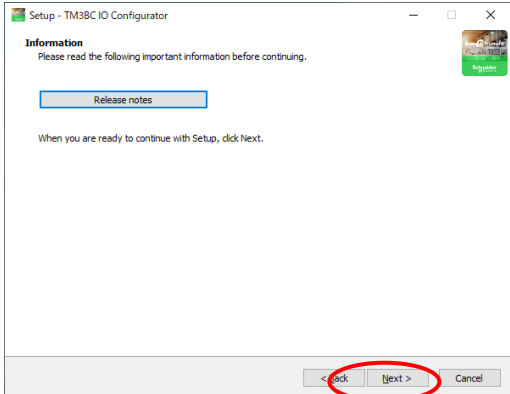
Step	Description												
1	<p>Make sure that your system meets the minimum configuration requirements to install and run TM3BC IO Configurator.</p> <table border="1"> <thead> <tr> <th>Item</th> <th>Minimum configuration</th> </tr> </thead> <tbody> <tr> <td>Processor</td> <td>Intel Core 2 Duo processor</td> </tr> <tr> <td>RAM</td> <td>1GB RAM</td> </tr> <tr> <td>Display Resolution</td> <td>1280 x 768 pixels</td> </tr> <tr> <td>OS</td> <td>Microsoft Windows 7 (32-bit or 64-bit processor) Microsoft Windows 8 (32-bit or 64-bit processor) Microsoft Windows 8.1 (32-bit or 64-bit processor) Microsoft Windows 10 (32-bit or 64-bit processor)</td> </tr> <tr> <td>Free space</td> <td>400MB</td> </tr> </tbody> </table>	Item	Minimum configuration	Processor	Intel Core 2 Duo processor	RAM	1GB RAM	Display Resolution	1280 x 768 pixels	OS	Microsoft Windows 7 (32-bit or 64-bit processor) Microsoft Windows 8 (32-bit or 64-bit processor) Microsoft Windows 8.1 (32-bit or 64-bit processor) Microsoft Windows 10 (32-bit or 64-bit processor)	Free space	400MB
Item	Minimum configuration												
Processor	Intel Core 2 Duo processor												
RAM	1GB RAM												
Display Resolution	1280 x 768 pixels												
OS	Microsoft Windows 7 (32-bit or 64-bit processor) Microsoft Windows 8 (32-bit or 64-bit processor) Microsoft Windows 8.1 (32-bit or 64-bit processor) Microsoft Windows 10 (32-bit or 64-bit processor)												
Free space	400MB												
2	Make sure that you are connected as an administrator of the workstation.												
3	Launch TM3BC IO Configurator.exe												
4	<p>Select the language for the installation from the drop-down list and confirm by clicking OK.</p> <p>NOTE: The selected language is used for the TM3BC IO Configurator installation and execution.</p>												

Step	Procedure
5	<p>Click [Next].</p> 
6	<p>Read the software license, confirm that you agree by checking the I accept the agreement box and click [Next] to continue.</p> 
7	<p>Read the Release Notes dialog then click [Next] to continue.</p> 

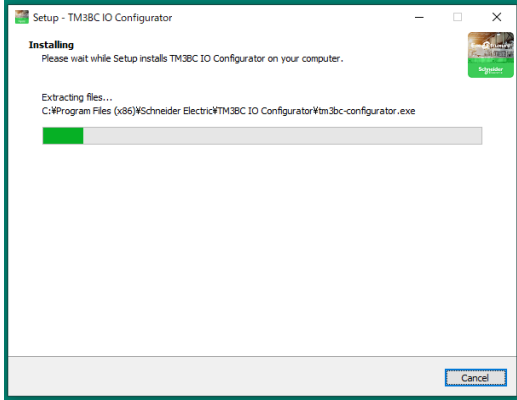
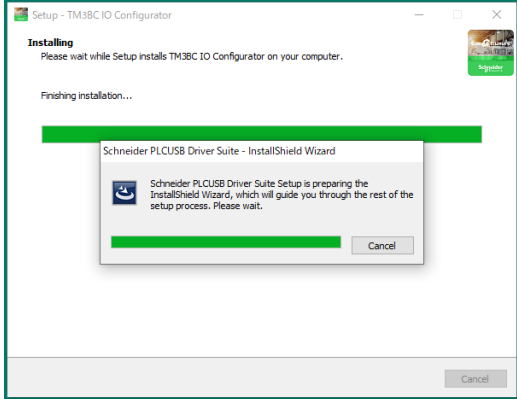
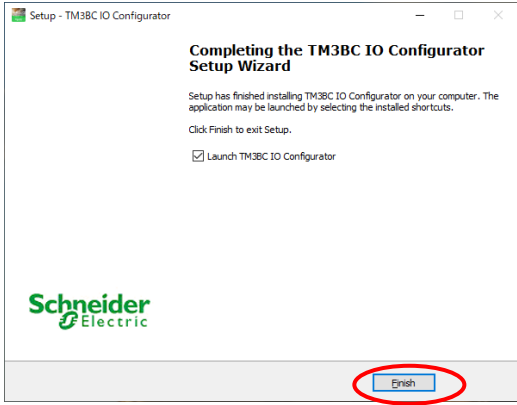
Step	Procedure
8	<p>Setting folder and click [Next]</p>
9	<p>Select the shortcuts needed and click Next to continue</p>
10	<p>Click [Install] to begin the installation.</p>

Step	Procedure
11	<p data-bbox="368 271 799 300">Display status bar when start install.</p>  <p data-bbox="368 748 1278 777">The following screen is displayed during installation, but there is no problem.</p> 
12	<p data-bbox="368 1227 943 1256">Click Finish to complete the installation process.</p> 
13	<p data-bbox="368 1720 967 1805">You can select Launch TM3BC IO Configurator (Launch desktop shortcut or Windows->Start )</p> 

8.4 TM3BC IO Configurator Operation Procedure

* Note: The procedure is an image of version 1.1.9.1.
If the version is different, the procedure image may be different.

8.4.1 Main Screen

(Screen when open)

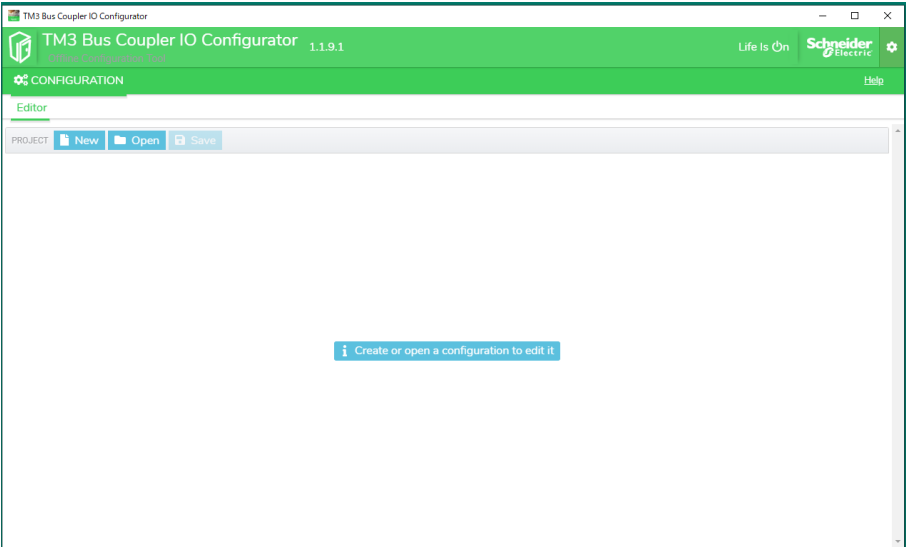

(Screen at operation)

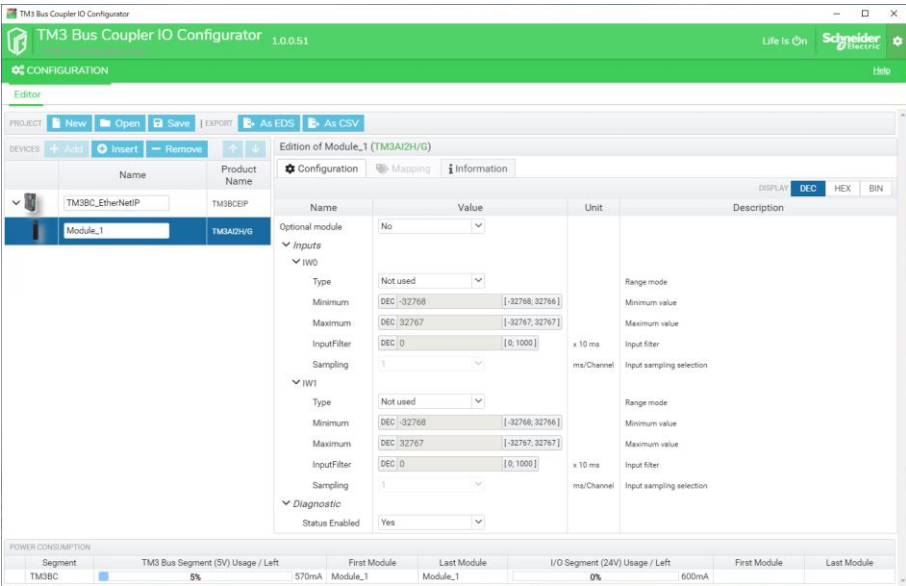

8.4.2 Create New Project

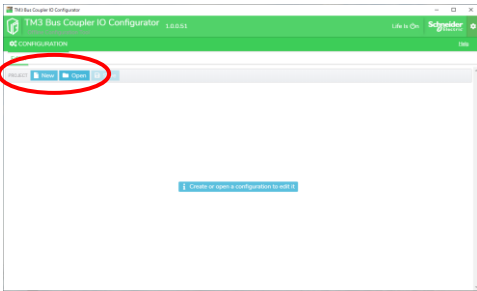
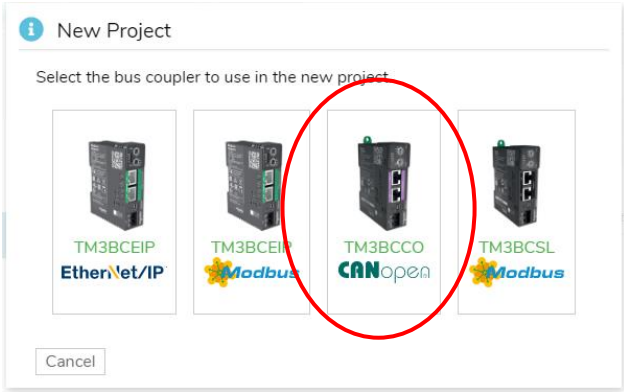
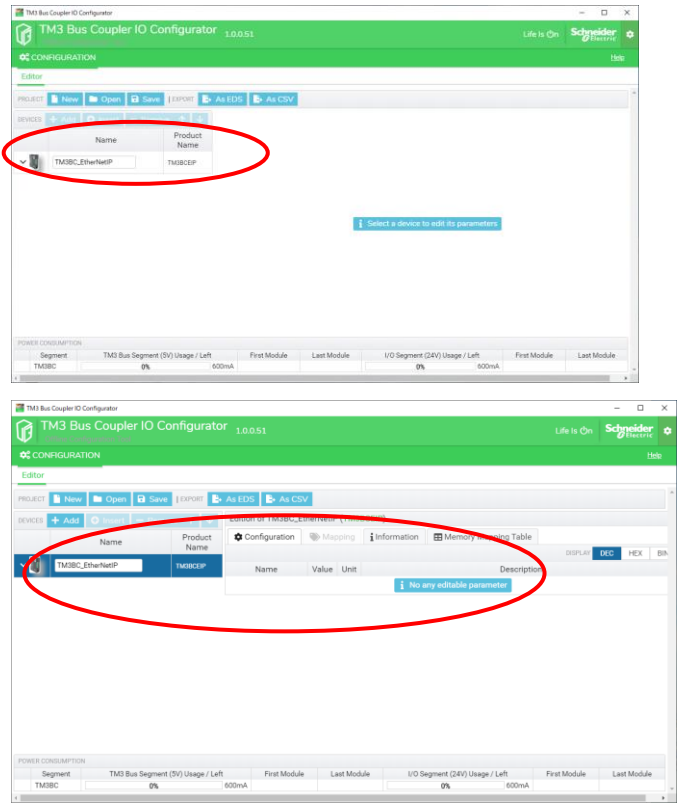
Step	Procedure
1	<p>Launch TM3BC IO Configurator and click [New].</p> 
2	<p>Select [TM3BCCO CANopen].</p> 
3	<p>Click [Device Name] to display detailed information.</p> 

8.4.3 Add new devices

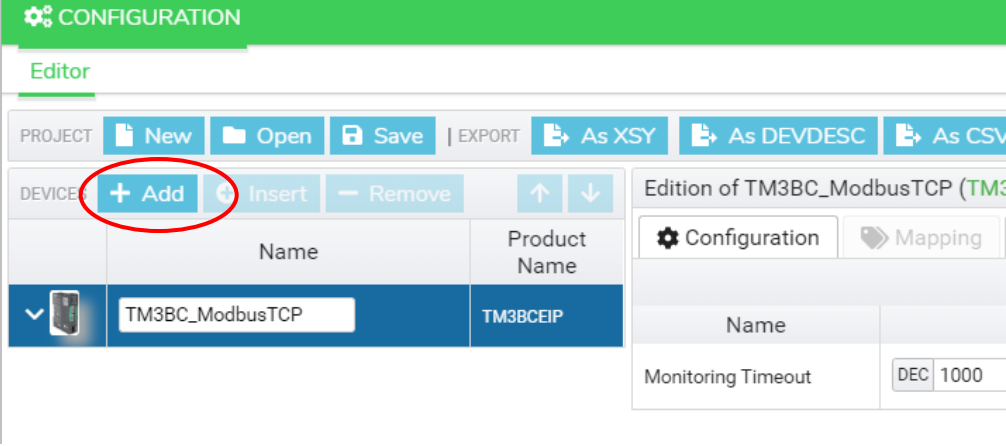
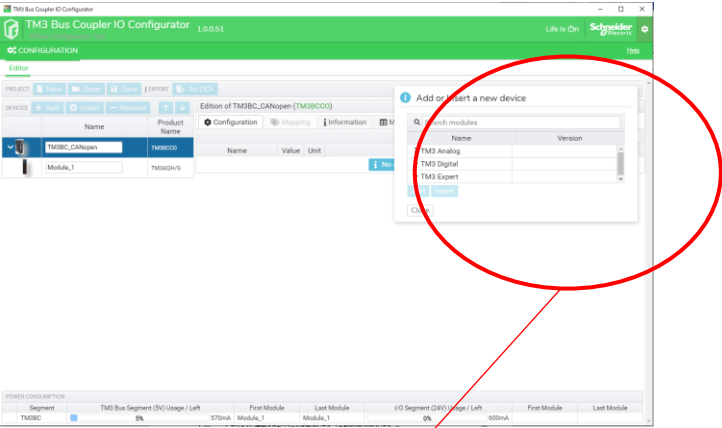
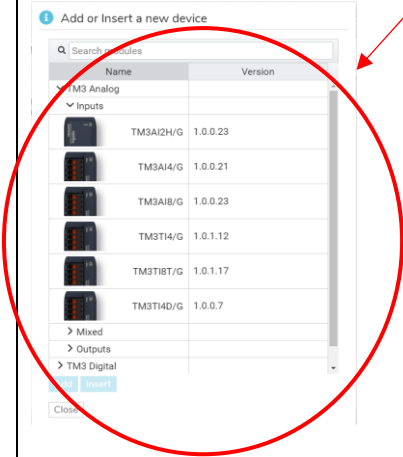
Step	Procedure
1	<p>Add device connect to bus coupler. Click [+Add]</p> 
2	<p>Display selection menu appears.</p>  <p>Select the device to connect from the list. (The following is after deployment)</p> 

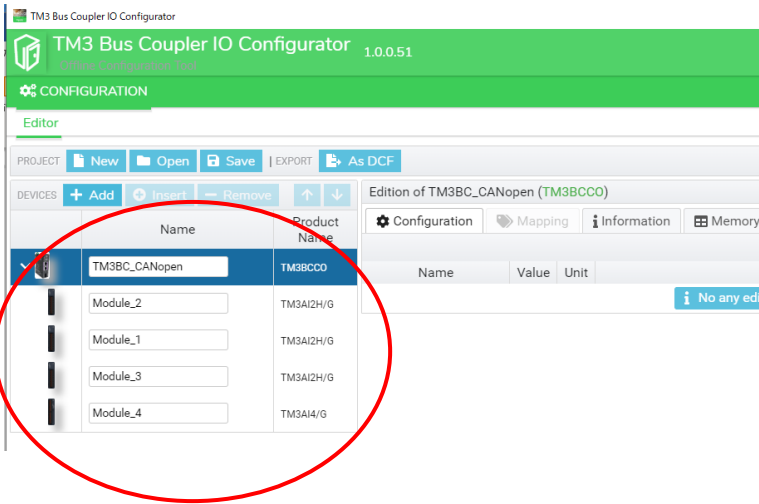
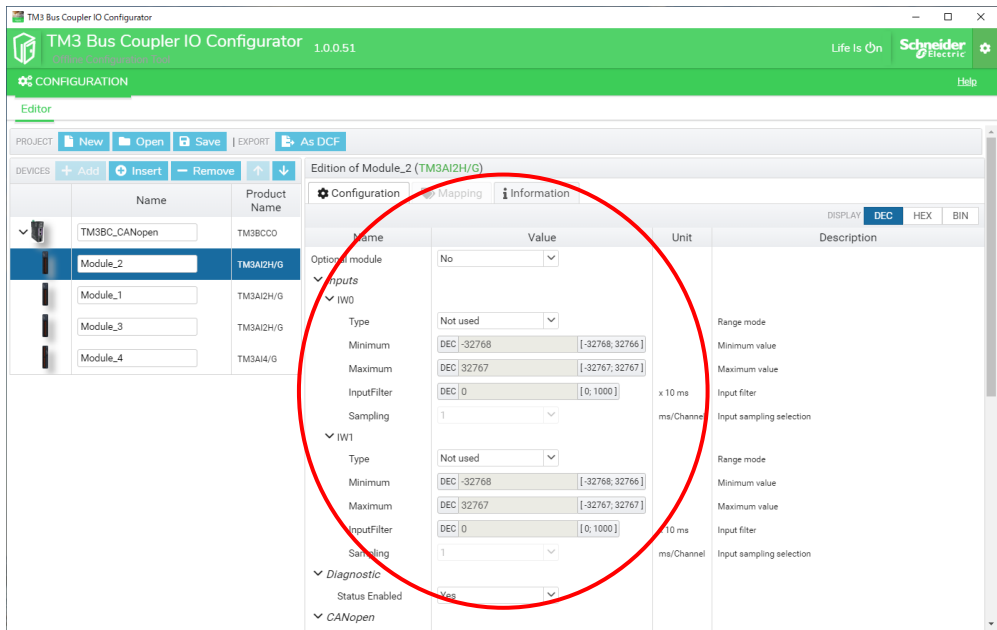
Step	Procedure																																																																
3	<p>Added device as below,</p>  <p>The screenshot shows the 'TM3 Bus Coupler IO Configurator' interface. At the top, it says 'TM3 Bus Coupler IO Configurator 1.0.0.51 Online Configuration Tool'. Below that is a 'CONFIGURATION' section with an 'Editor' tab. A menu bar includes 'PROJECT', 'New', 'Open', 'Save', 'EXPORT', and 'As DCF'. On the left, a 'DEVICES' table lists the following:</p> <table border="1"> <thead> <tr> <th>Name</th> <th>Product Name</th> </tr> </thead> <tbody> <tr> <td>TM3BC_CANopen</td> <td>TM3BCCO</td> </tr> <tr> <td>Module_2</td> <td>TM3AI2H/G</td> </tr> <tr> <td>Module_1</td> <td>TM3AI2H/G</td> </tr> <tr> <td>Module_3</td> <td>TM3AI2H/G</td> </tr> <tr> <td>Module_4</td> <td>TM3AI4/G</td> </tr> </tbody> </table> <p>The 'TM3BC_CANopen' device and its modules are circled in red. To the right, the 'Edition of TM3BC_CANopen (TM3BCCO)' panel shows tabs for 'Configuration', 'Mapping', 'Information', and 'Memory'. A table with columns 'Name', 'Value', and 'Unit' is visible, with a 'No any ed' button at the bottom right.</p>	Name	Product Name	TM3BC_CANopen	TM3BCCO	Module_2	TM3AI2H/G	Module_1	TM3AI2H/G	Module_3	TM3AI2H/G	Module_4	TM3AI4/G																																																				
Name	Product Name																																																																
TM3BC_CANopen	TM3BCCO																																																																
Module_2	TM3AI2H/G																																																																
Module_1	TM3AI2H/G																																																																
Module_3	TM3AI2H/G																																																																
Module_4	TM3AI4/G																																																																
4	<p>Click each device to enable setting description.</p>  <p>The screenshot shows the 'Edition of Module_2 (TM3AI2H/G)' configuration window. The 'DEVICES' table on the left is the same as in the previous screenshot. The main configuration area is titled 'Edition of Module_2 (TM3AI2H/G)' and has tabs for 'Configuration', 'Mapping', and 'Information'. The 'Configuration' tab is active, showing a table with columns 'Name', 'Value', 'Unit', and 'Description'. A red circle highlights the configuration parameters for the 'IWO' and 'IW1' inputs:</p> <table border="1"> <thead> <tr> <th>Name</th> <th>Value</th> <th>Unit</th> <th>Description</th> </tr> </thead> <tbody> <tr> <td>Optional module</td> <td>No</td> <td></td> <td></td> </tr> <tr> <td>Inputs</td> <td></td> <td></td> <td></td> </tr> <tr> <td>Type</td> <td>Not used</td> <td></td> <td>Range mode</td> </tr> <tr> <td>Minimum</td> <td>DEC: -32768</td> <td>[-32768, 32766]</td> <td>Minimum value</td> </tr> <tr> <td>Maximum</td> <td>DEC: 32767</td> <td>[-32767, 32767]</td> <td>Maximum value</td> </tr> <tr> <td>InputFilter</td> <td>DEC: 0</td> <td>[0, 1000]</td> <td>x 10 ms Input filter</td> </tr> <tr> <td>Sampling</td> <td>1</td> <td></td> <td>ms/Channel Input sampling selection</td> </tr> <tr> <td>IW1</td> <td></td> <td></td> <td></td> </tr> <tr> <td>Type</td> <td>Not used</td> <td></td> <td>Range mode</td> </tr> <tr> <td>Minimum</td> <td>DEC: -32768</td> <td>[-32768, 32766]</td> <td>Minimum value</td> </tr> <tr> <td>Maximum</td> <td>DEC: 32767</td> <td>[-32767, 32767]</td> <td>Maximum value</td> </tr> <tr> <td>InputFilter</td> <td>DEC: 0</td> <td>[0, 1000]</td> <td>x 10 ms Input filter</td> </tr> <tr> <td>Sampling</td> <td>1</td> <td></td> <td>ms/Channel Input sampling selection</td> </tr> <tr> <td>Diagnostic Status Enabled</td> <td>Yes</td> <td></td> <td></td> </tr> <tr> <td>CANopen</td> <td></td> <td></td> <td></td> </tr> </tbody> </table>	Name	Value	Unit	Description	Optional module	No			Inputs				Type	Not used		Range mode	Minimum	DEC: -32768	[-32768, 32766]	Minimum value	Maximum	DEC: 32767	[-32767, 32767]	Maximum value	InputFilter	DEC: 0	[0, 1000]	x 10 ms Input filter	Sampling	1		ms/Channel Input sampling selection	IW1				Type	Not used		Range mode	Minimum	DEC: -32768	[-32768, 32766]	Minimum value	Maximum	DEC: 32767	[-32767, 32767]	Maximum value	InputFilter	DEC: 0	[0, 1000]	x 10 ms Input filter	Sampling	1		ms/Channel Input sampling selection	Diagnostic Status Enabled	Yes			CANopen			
Name	Value	Unit	Description																																																														
Optional module	No																																																																
Inputs																																																																	
Type	Not used		Range mode																																																														
Minimum	DEC: -32768	[-32768, 32766]	Minimum value																																																														
Maximum	DEC: 32767	[-32767, 32767]	Maximum value																																																														
InputFilter	DEC: 0	[0, 1000]	x 10 ms Input filter																																																														
Sampling	1		ms/Channel Input sampling selection																																																														
IW1																																																																	
Type	Not used		Range mode																																																														
Minimum	DEC: -32768	[-32768, 32766]	Minimum value																																																														
Maximum	DEC: 32767	[-32767, 32767]	Maximum value																																																														
InputFilter	DEC: 0	[0, 1000]	x 10 ms Input filter																																																														
Sampling	1		ms/Channel Input sampling selection																																																														
Diagnostic Status Enabled	Yes																																																																
CANopen																																																																	

8.4.4 Configuration of data range

(Important) Difference of analog input resolution

Sample: EXM-AMI2HT and TM3AI2H

EXM	Configuration	Data Range	TM3	Configuration	Data Range
EXM-AMI2HT	Fixed	0 ... 4095	TM3-AI2H	Fixed	0 ... 65535 *1
	User Setting	-32768 ... 32767		User Setting	-32768 ... 32767

*1 If you want to replace EXM with TM3, please change the setting of IO Configurator.

GP-Pro EX

Module: Information: Analog Module: Input2Points
Voltage (0 - 10V) / Current (4 - 20mA)

Input1.2

CH1

Data Format (S)

Voltage (0 - 10V)

Data Range

Fixed (F) User Defined (U)

Maximum (H)

Minimum (L)

CH2

Data Format (R)

Current (4 - 20mA)

Data Range

Fixed (F) User Defined (U)

Maximum (H)

Minimum (L)

TM3 IO Configurator

[Not Used] -> [0-10V], [4-20mA]

Inputs

IW0

Type:

Minimum: DEC -32768 [-32768; 32766]

Maximum: DEC 32767 [-32767; 32767]

InputFilter: DEC 0 [0; 1000]

Sampling:

IW1

Type:

Minimum: DEC -32768 [-32768; 32766]

Maximum: DEC 32767 [-32767; 32767]

InputFilter: DEC 0 [0; 1000]

Sampling:

➔

Inputs

IW0

Type:

Minimum: DEC 0 [-32768; 4094]

Maximum: DEC 4095 [1; 32767]

InputFilter: DEC 0 [0; 1000]

Sampling:

IW1

Type:

Minimum: DEC 0 [-32768; 4094]

Maximum: DEC 4095 [1; 32767]

InputFilter: DEC 0 [0; 1000]

Sampling:

8.4.5 Data Export

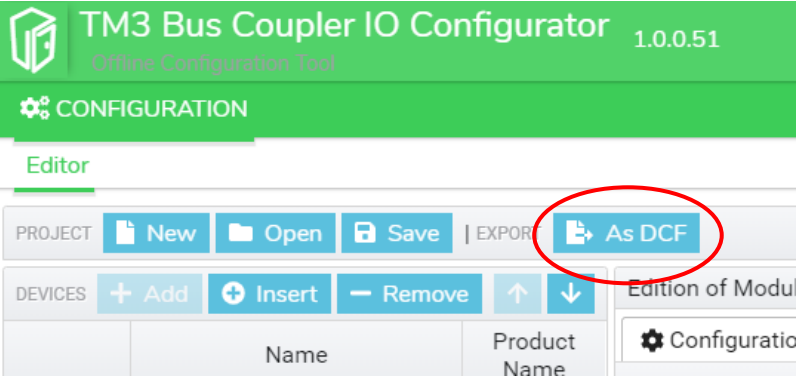
Step	Procedure
1	<p>Click the button next to Export at the top left of the screen.</p>  <p>* The data will be saved in any folder.</p>

8.4.6 Data Import

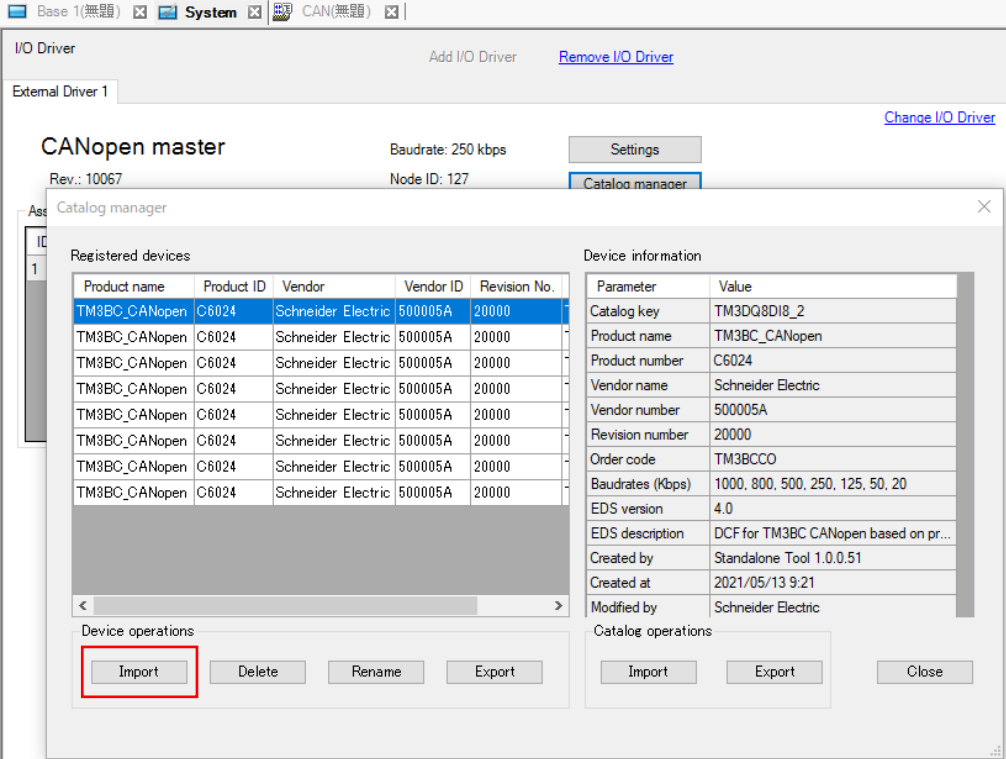
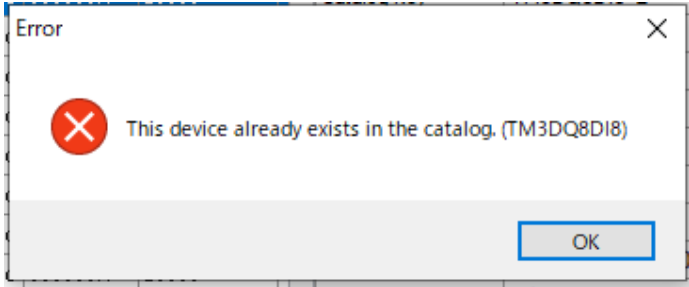
Step	Procedure
1	<p data-bbox="347 309 491 338">Data import</p> <p data-bbox="368 353 839 387">Import the DCF file set into GP-Pro EX.</p>  <p data-bbox="347 1218 430 1247">Notes:</p> <p data-bbox="347 1263 1374 1346">When editing the data created by the configurator and re-importing it, if the data name (device registration name) is duplicated, it cannot be imported.</p>  <p data-bbox="347 1648 1106 1682">Delete the data or rename the data before executing the import.</p> <p data-bbox="347 1695 1430 1778">Also, when you delete the data, the set IO allocation settings are also deleted. Be careful if you have IO assignments.</p>

8.5 Limitations

The limitations are shown below.

	Description	Note
1	Do not enter negative values for the Upper limit threshold and Lower limit threshold of the Analog module.	Data cannot be sent correctly with a negative value setting. Please change to the delta setting so that you can get the data.
2	In the case you change the settings for TM3BC with GP-Pro EX, restart the power of TM3BC after transferring the project data	This change will only take effect after a reboot.

9 When using TM3 modules as Remote I/O (EtherNet/IP)

9.1 Overview

By using the TM3 Bus Coupler EtherNet/IP compatible module (TM3BCEIP), you can control TM3 modules in remote locations. The only display that supports this function is STC6000 series.

Note: EtherNet/IP communication is supported by GP-Pro EX Ver.4.09.550 or later. EIP driver is used as the I/O driver. The EIP driver connects STC6000 and TM3BCEIP using Explicit message communication or Implicit message communication.

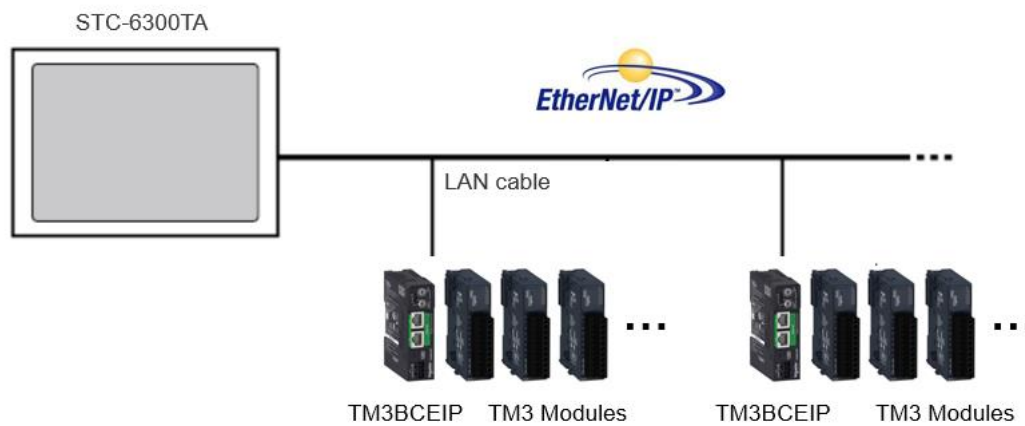

*EtherNet/IP is an open network managed by ODVA.

*EtherNet/IP specifications are defined by ODVA and can be found on the ODVA website.

<https://www.odva.org/>

9.2 EIP Driver specifications

The specifications of EIP driver are as follows. The EIP driver does not obtain ODVA Certification.

Functionality of EtherNet/IP	Spec of EIP Driver
Class1(Implicit Message)	Yes
Class3(Explicit Message with connection)	Yes
UCMM (Explicit Message without connection)	Yes
Send Configuration Data	No
DLR	No
QoS	No
CIP Security	No
CIP Safety	No
Numbers of Connections	Class1: 32 Class3/UCMM: Total 15
Connection Size (Fixed/Variable)	Fixed only
RPI (ms)	10 ms *1
PPS	3200 pps
Max. Input bytes/packet	Class1: 128
Max. Output bytes/packet	Class1: 128
Max. Total Input bytes (Refresh Size)	Class1: 128
Max. Total Output bytes (Refresh Size)	Class1: 128
Max. Adapters	32

*1 It can be set from 2ms. However, since the logic minimum scan time is 10ms, we recommend setting the RPI to 10ms.

9.3 TM3BCEIP specifications

When using TM3 Module on EtherNet/IP, it is necessary to use TM3 Ethernet Bus Coupler TM3BCEIP.

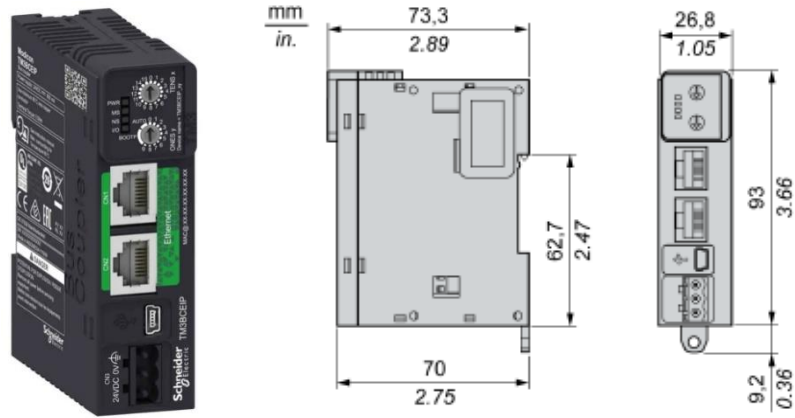

This table describes the Main characteristics:

Characteristics	Description
Rate power supply	24 Vdc
Weight	100 g (3.53 oz)
Rotary switch	2
Ethernet	2 (isolated switched Ethernet ports: 10 Mbps / 100 Mbps)
Power supply connection type	Removable screw terminal block
1 USB port	USB 2.0, USB mini-B
Connector insertion/removal durability	Over 100 times
Supplied power available for connected inputs and outputs modules	600 mA maximum
Current draw on 5 Vdc and 24 Vdc internal bus	

This table describes the Ethernet characteristics:

Characteristics	Description
Function	Modbus TCP, EtherNet/IP
Connector type	RJ45
Auto negotiation	From 10 Mbps half duplex to 100 Mbps full duplex
Cable type	Shielded
Automatic cross-over detection	Yes
Topology	Ring type

NOTE: For more information, please refer to the hardware manual of TM3BCEIP.

9.4 Connectable TM3 modules to TM3BCEIP (EtherNet/IP)

Any TM3 modules supported by TM3BCEIP can be used for this EtherNet/IP connection. For more information, please refer to the hardware manual of TM3BCEIP.

9.5 Number of connectable TM3 modules

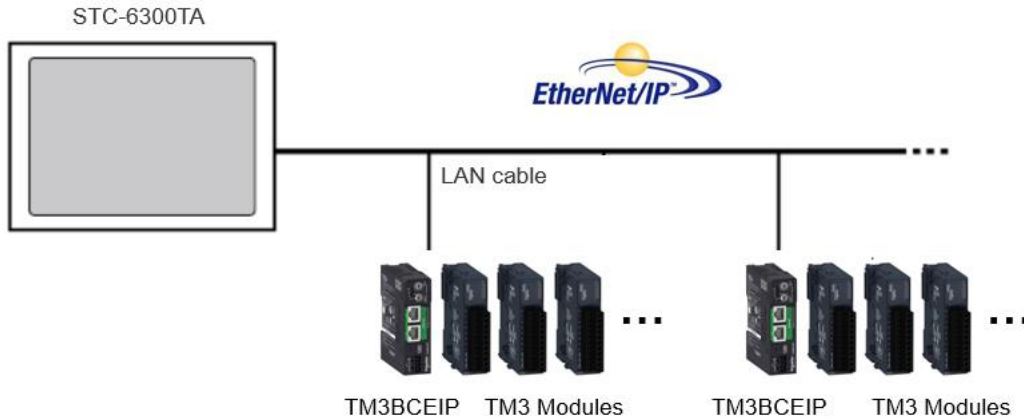

Each display unit (STC-6300TA) supports up to:

Module type	Maximum number of connectable TM3 modules
TM3BCEIP	32 units

Each TM3 bus coupler (TM3BCEIP) supports up to:

Module type	Maximum number of connectable TM3 modules
TM3 modules	7 units without transmitter and receiver 13 units with transmitter and receiver

NOTE: The number of input/output integer points that can be set is up to 256 points (128 input integer points, 128 output integer points).

9.6 Setup procedure for EtherNet/IP

9.6.1 Workflow

Follow the 6 steps to connect STC6000 and TM3BCEIP. Each step is explained from the next slide.

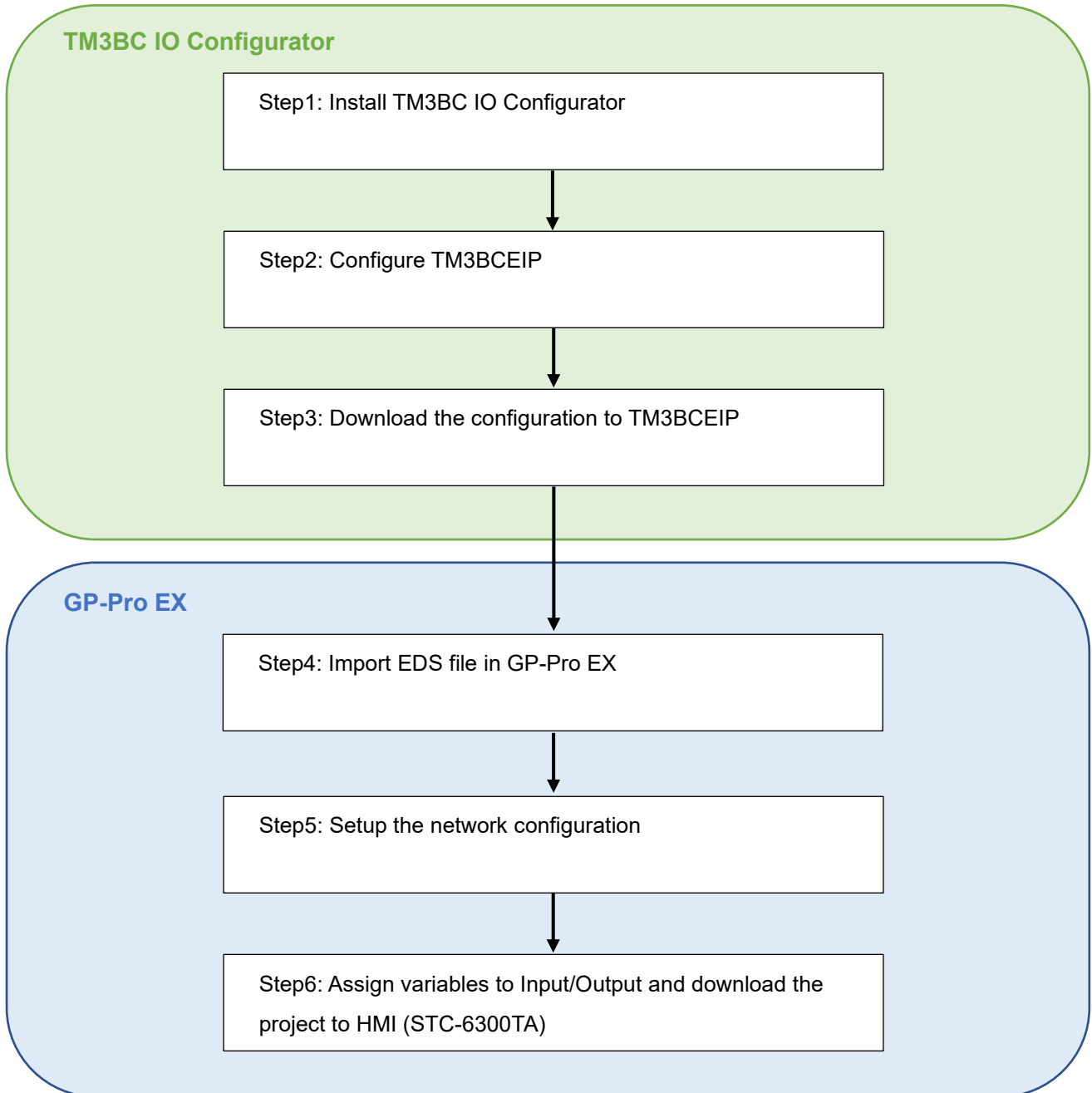

9.6.2 Install TM3BC IO Configurator

Download and install the TM3BC IO Configurator that matches the Firmware version of your TM3BCEIP.

Reference	Modicon TM3 Bus Couplers Firmware Version	TM3 Bus Coupler IO Configurator Software Version
TM3BCEIP	1.2.1.1	Not Supported
	1.3.1.2	
	2.1.50.2	1.0.0
	2.2.1.1	1.1.9
	2.3.0.15	1.2.0
	2.4.0.3	
		1.3.1

<Download site>

https://www.se.com/ww/en/download/document/TM3BC_IO_Configurator/

If the link destination may differ depending on the update of the website. In that case, please search with [TM3BC IO Configurator].

9.6.3 Configure TM3BCEIP

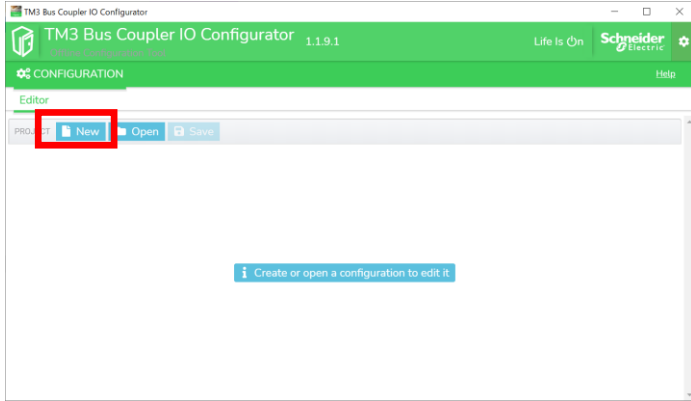
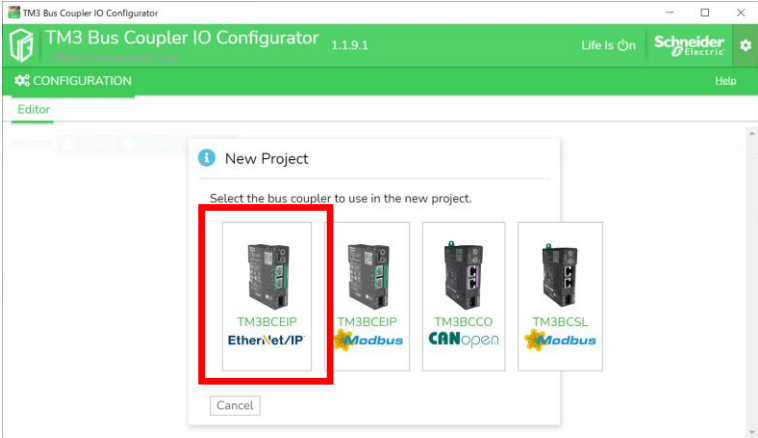
Step	Procedure
1	<p>Open TM3BC IO Configurator. Click [New].</p> 
2	<p>Select [TM3BCEIP].</p> 

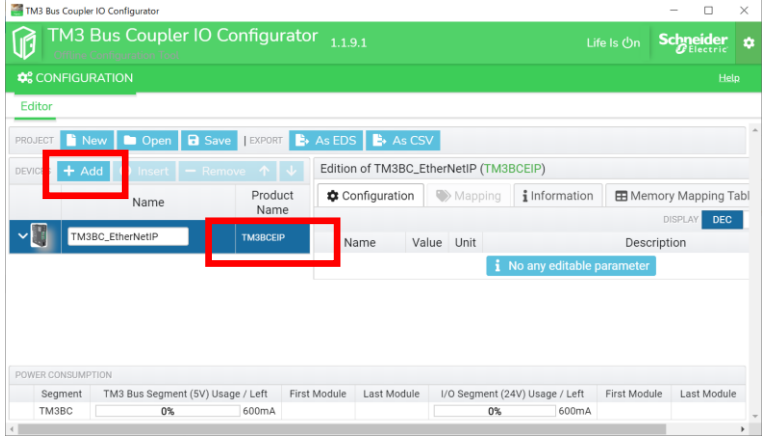
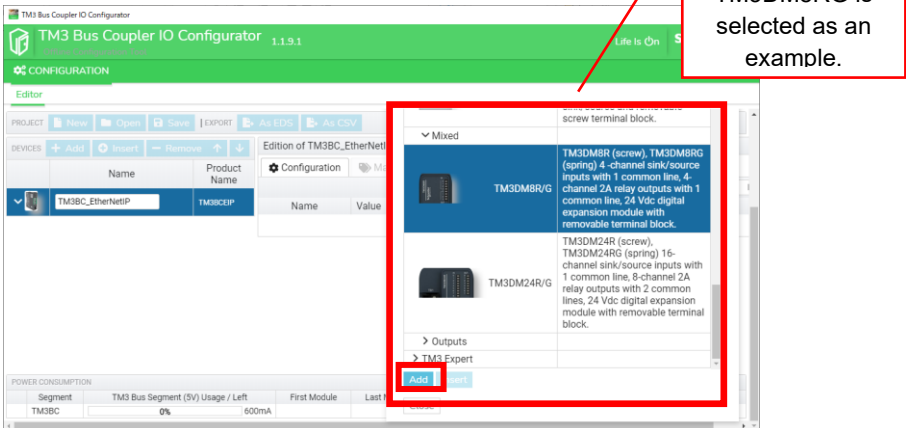
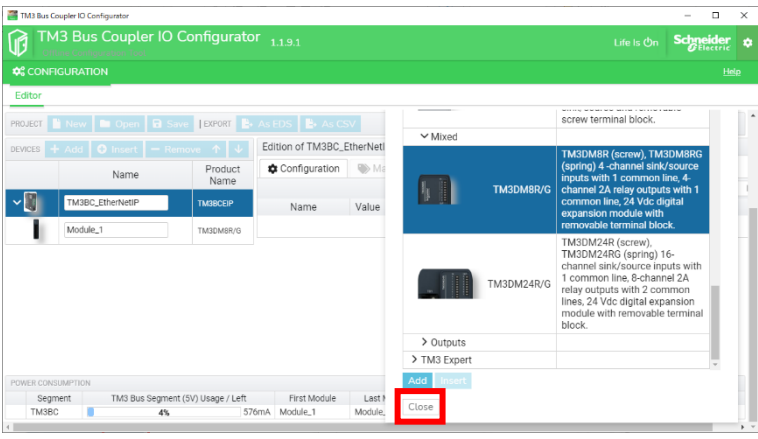
Step	Procedure
3	<p>Click on the product name “TM3BCEIP” and “Add”.</p> 
4	<p>Select a TM3 Module from the list and click “Add”.</p> 
5	<p>Click [Close].</p> 

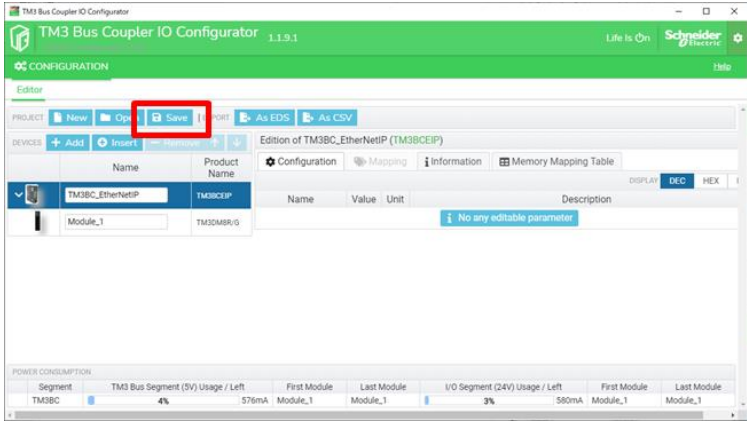
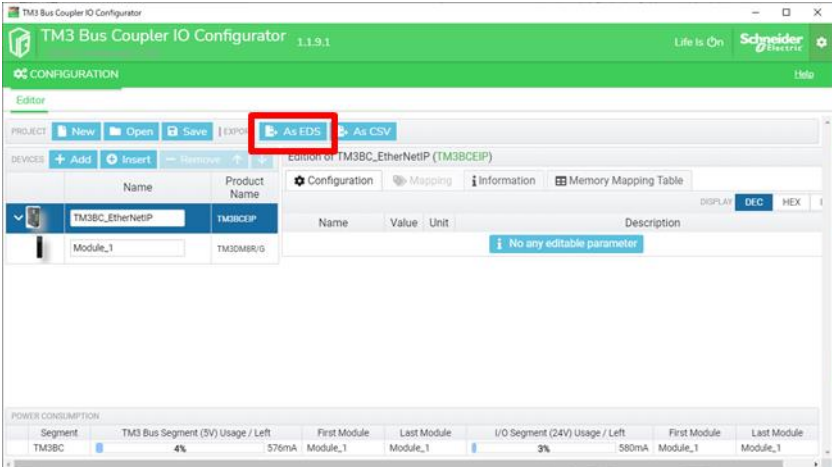
Step	Procedure
6	<p>Click [Save]. Enter a file name and save the SPF file.</p>  <p>The screenshot shows the 'TM3 Bus Coupler IO Configurator' software interface. The 'Editor' menu is open, and the 'Save' option is highlighted with a red rectangular box. The interface includes a 'PROJECT' menu with options like 'New', 'Open', and 'Save', and a 'DEVICES' section with a table listing 'TM3BC_EtherNetIP' and 'Module_1'. A 'POWER CONSUMPTION' table at the bottom shows usage for 'TM3BC' and 'I/O Segment (24V)'.</p>
7	<p>Click [As EDS]. Enter a file name and save the EDS file.</p>  <p>The screenshot shows the same software interface as in step 6. The 'Editor' menu is open, and the 'As EDS' option is highlighted with a red rectangular box. The 'DEVICES' table and 'POWER CONSUMPTION' table are visible in the same positions as in the previous screenshot.</p>

9.6.4 Download the configuration to TM3BCEIP

Step	Procedure
1	Connect a PC and TM3BCEIP via USB port. (Ensure the Ethernet cable is disconnected.)
2	Open the web browser.
3	Enter the IP address 90.0.0.1. 
4	Input Username and Password (Default: Administrator / Administrator)
5	Set IP address.
6	Open SPF file and apply the configuration to TM3BCEIP.
NOTE	For the details, please refer to Modicon TM3 Bus Coupler Programming Guide . https://www.se.com/ww/en/download/document/EIO000003643/

9.6.5 Import EDS file in GP-Pro EX

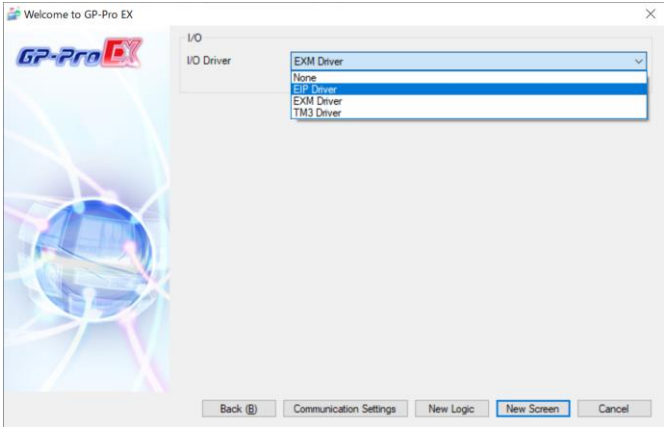
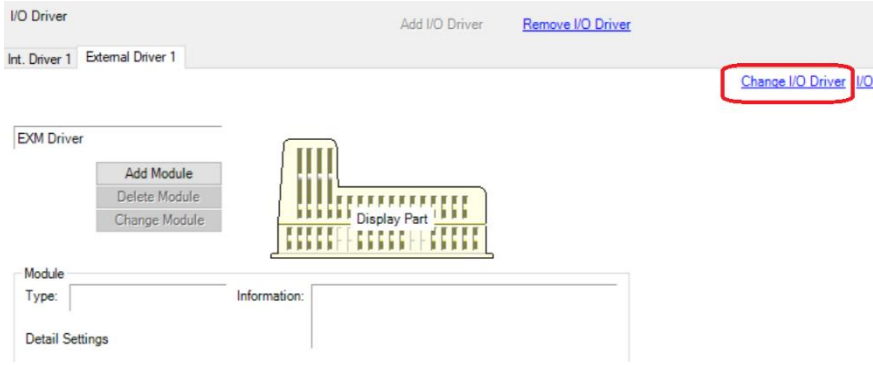
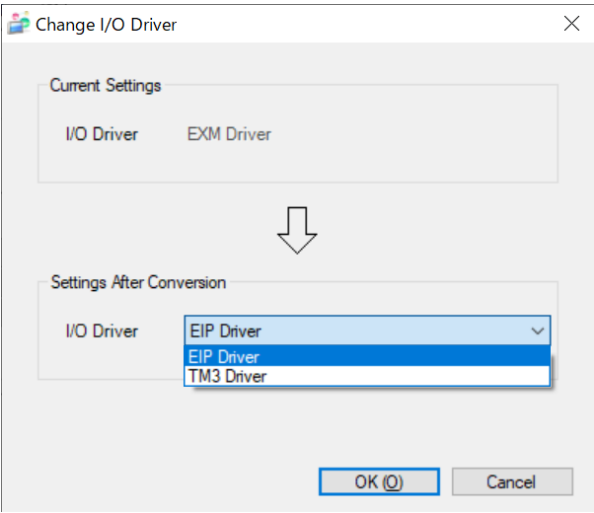
Step	Procedure
1	<p data-bbox="240 309 1139 342">If you newly create a project in GP-Pro EX, select [EIP Driver] as I/O Driver.</p>  <p data-bbox="240 835 1362 913">If a different I/O Driver is selected in your project, please go to GP-Pro EX [Project] → [System settings] → [I/O Driver settings] and select [EIP Driver] in [Change I/O Driver] screen.</p>  

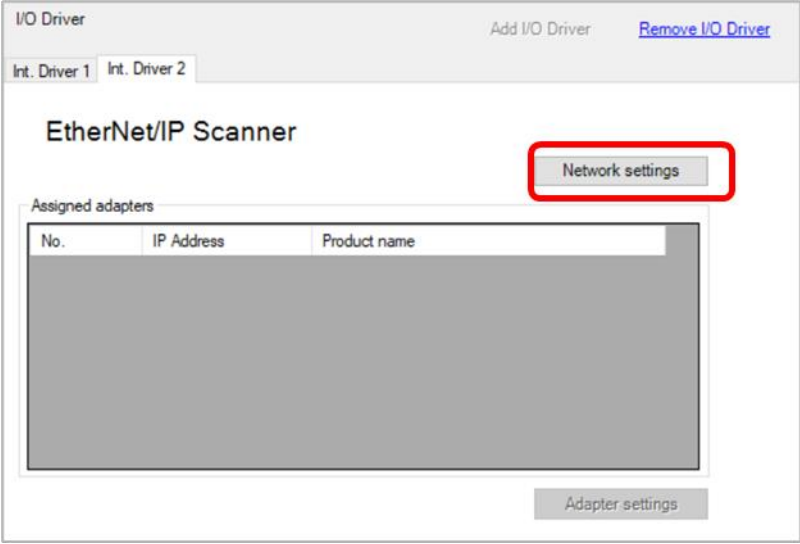
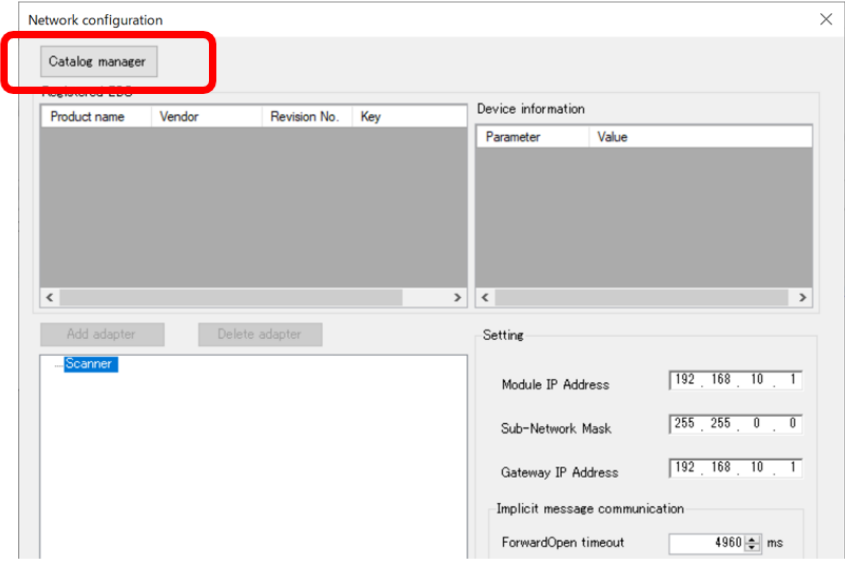
Step	Procedure
2	<p data-bbox="288 315 587 349">Click [Network settings].</p>  <p>The screenshot shows the 'EtherNet/IP Scanner' window. At the top, there are tabs for 'Int. Driver 1' and 'Int. Driver 2'. Below the title 'EtherNet/IP Scanner', there is a 'Network settings' button highlighted with a red rectangle. Below this, there is a section for 'Assigned adapters' with a table header: 'No.', 'IP Address', and 'Product name'. At the bottom right, there is an 'Adapter settings' button.</p>
3	<p data-bbox="288 987 596 1021">Click [Catalog manager].</p>  <p>The screenshot shows the 'Network configuration' dialog box. The 'Catalog manager' button is highlighted with a red rectangle. Below the dialog title, there are two main sections: 'Registered EIP' and 'Device information'. The 'Registered EIP' section has a table with columns: 'Product name', 'Vendor', 'Revision No.', and 'Key'. The 'Device information' section has a table with columns: 'Parameter' and 'Value'. Below these sections are 'Add adapter' and 'Delete adapter' buttons. At the bottom, there is a 'Setting' section with fields for 'Module IP Address' (192.168.10.1), 'Sub-Network Mask' (255.255.0.0), 'Gateway IP Address' (192.168.10.1), and 'Implicit message communication' with a 'ForwardOpen timeout' set to 4960 ms.</p>

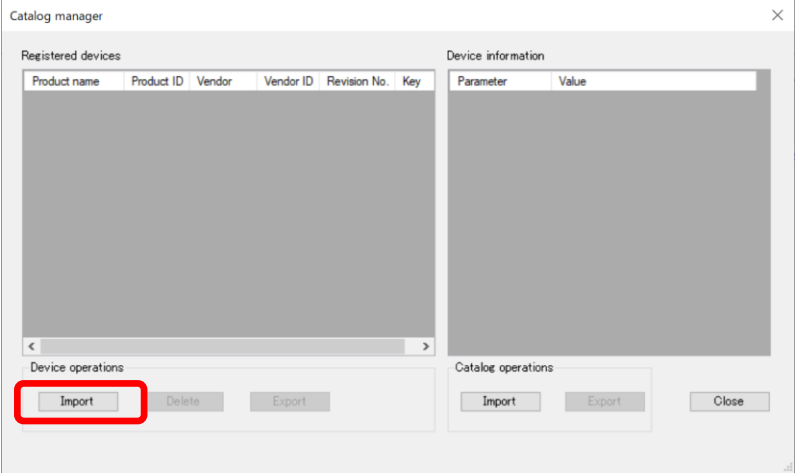
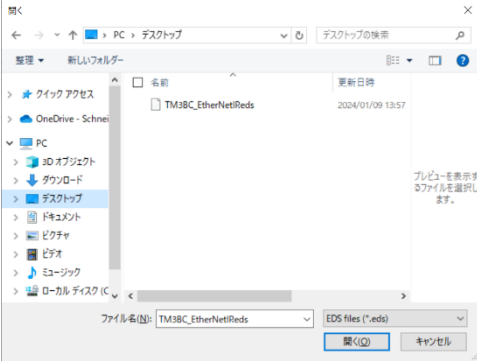
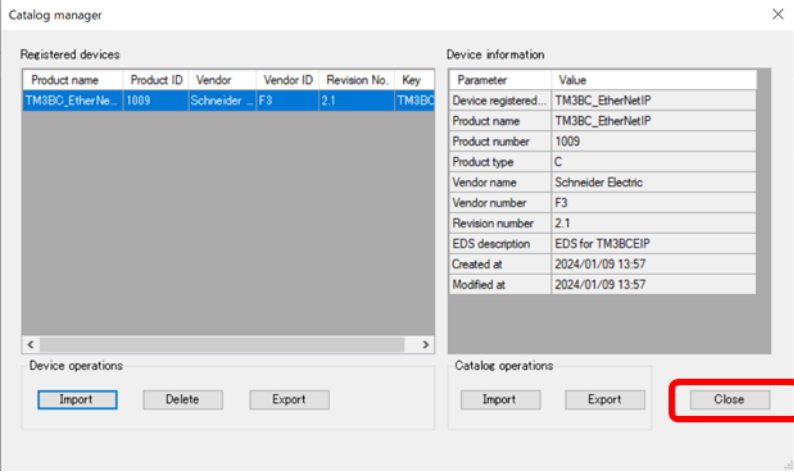
Step	Procedure
4	<p>Click [Import].</p>  <p>The screenshot shows the 'Catalog manager' window with two main panes: 'Registered devices' and 'Device information'. Below the panes are two sections of buttons: 'Device operations' and 'Catalog operations'. The 'Import' button in the 'Device operations' section is highlighted with a red rectangle.</p>
5	<p>Select the EDS file you want to import.</p>  <p>The screenshot shows a Windows File Explorer window. The address bar indicates the current location is 'PC > デスクトップ'. The file list shows a file named 'TM3BC_EtherNetReds' with a date of '2024/01/09 13:57'. The file is selected, and the file type is set to 'EDS files (*.eds)'. The '開く(O)' (Open) button is visible at the bottom right.</p>
6	<p>Click [Close].</p>  <p>The screenshot shows the 'Catalog manager' window with the 'Registered devices' table populated with one entry: 'TM3BC_EtherNetIP' with Product ID '1009', Vendor 'Schneider Electric', Vendor ID 'F3', Revision No. '2.1', and Key 'TM3BC'. The 'Device information' pane shows details for this device. The 'Close' button in the 'Catalog operations' section is highlighted with a red rectangle.</p>

9.6.6 Setup the network configuration

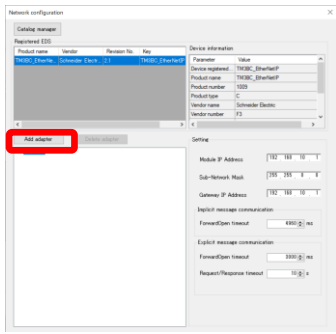
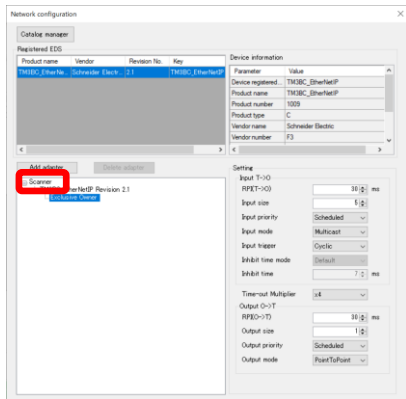
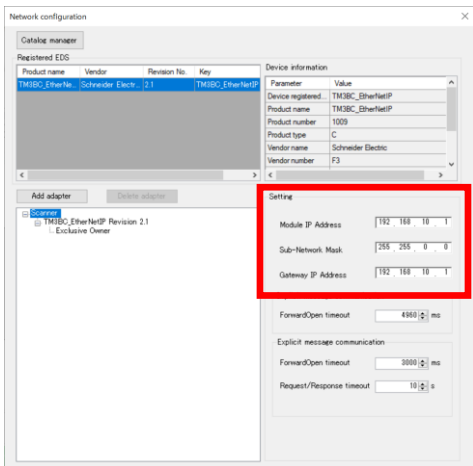
Step	Procedure
1	<p>Click [Add adapter].</p> 
2	<p>Select [Scanner].</p> 
3	<p>Match the [Module IP address], [Sub-Network Mask] and [Gateway IP Address] to the settings of the display unit (STC-6300TA).</p> 

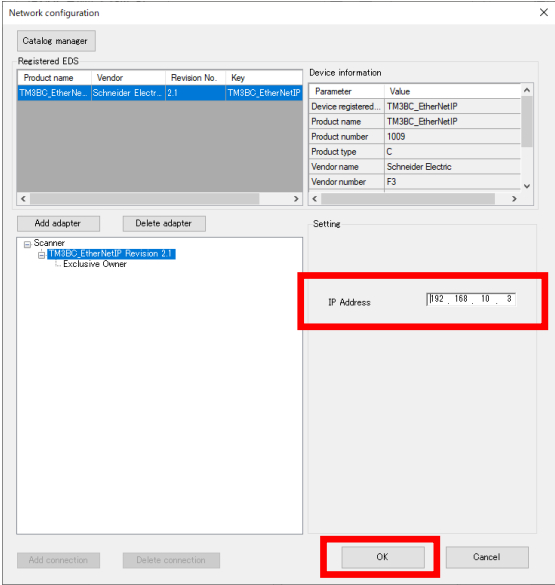
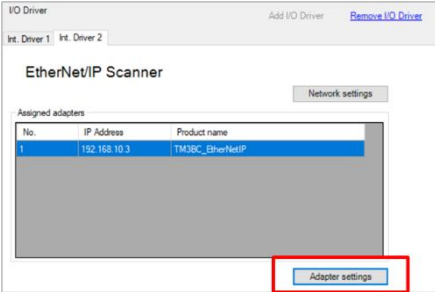
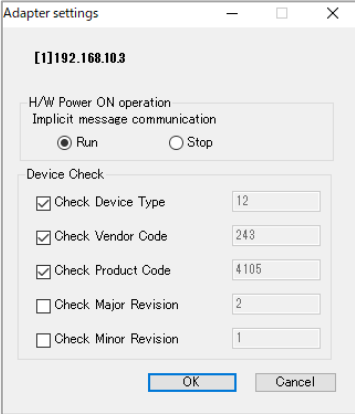
Step	Procedure
4	<p>Select the adapter you added.</p> <p>Match the [IP address] to the setting of the adapter.</p> 
5	<p>Select an adapter from [Assigned adapters] and click [Adapter Settings].</p> 
6	<p>The following dialog box will be displayed. Please make the settings if necessary.</p> 

9.6.7 Assign variables to Input/Output and Transfer to STC-6300TA

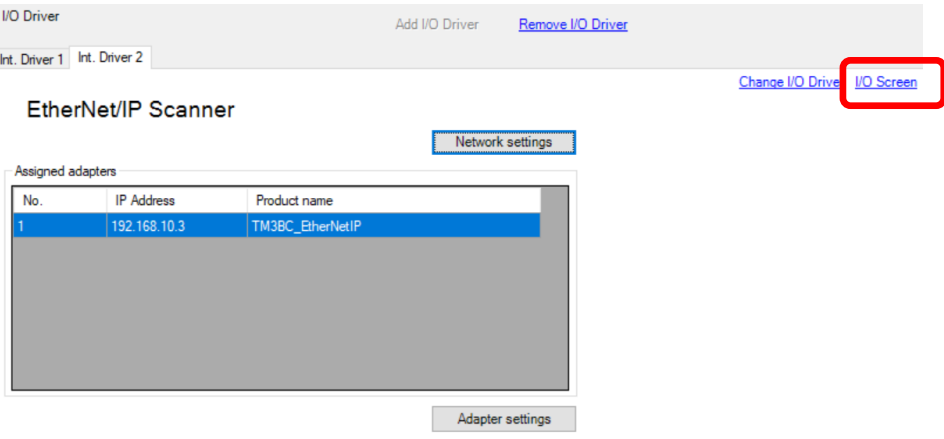
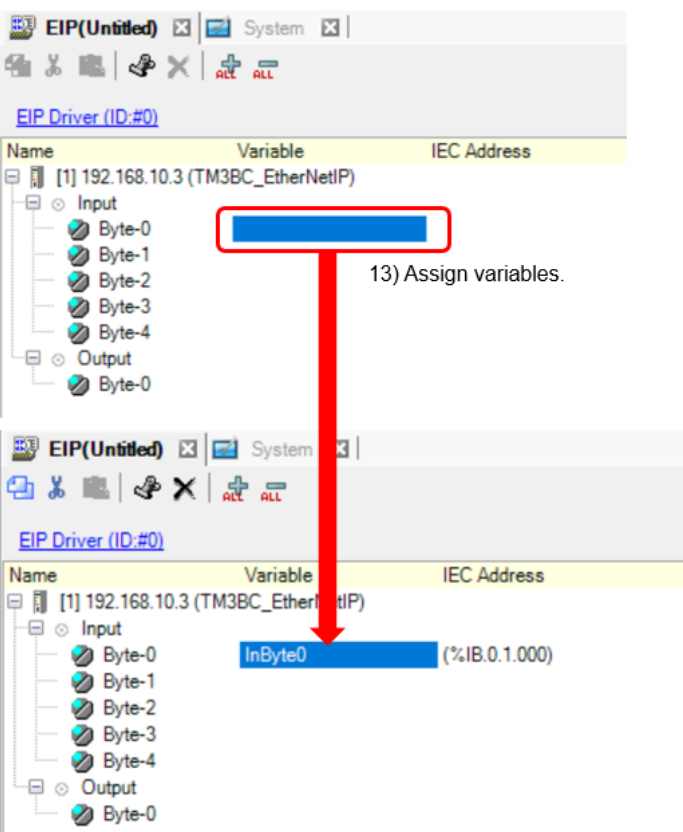
Step	Procedure
1	<p>Click [I/O Screen].</p>  <p>The screenshot shows the 'I/O Driver' configuration interface. At the top, there are buttons for 'Add I/O Driver' and 'Remove I/O Driver'. Below that, there are tabs for 'Int. Driver 1' and 'Int. Driver 2'. On the right side, there are links for 'Change I/O Drive' and 'I/O Screen', with the latter being highlighted by a red rectangular box. The main area is titled 'EtherNet/IP Scanner' and contains a 'Network settings' button. Below this is a table of 'Assigned adapters' with columns for 'No.', 'IP Address', and 'Product name'. The table contains one entry: No. 1, IP Address 192.168.10.3, and Product name TM3BC_EtherNetIP. At the bottom, there is an 'Adapter settings' button.</p>
2	<p>Assign variables.</p>  <p>The first screenshot shows the 'EIP Driver (ID:#0)' configuration window. It has a tree view on the left with 'Input' and 'Output' folders. Under 'Input', there are five 'Byte-0' through 'Byte-4' items. A red rectangular box highlights the 'Byte-0' item. To the right of this box, the text '13) Assign variables.' is present. A red arrow points downwards from the 'Byte-0' box to the second screenshot.</p> <p>The second screenshot shows the same configuration window, but now the 'Byte-0' item is expanded to show a variable named 'InByte0' with the IEC address '%IB.0.1.000'.</p>
3	<p>Create a logic screen or base screen to access the assigned variables. Transfer the project file to HMI (STC6000).</p>

NOTE: About the limitations of EIP Driver, please refer to GP-Pro EX reference manual.

<https://www.pro-face.com/otasuke/files/manual/gpproex/new/refer/gpproex.htm>

10 When using TM3 modules as local expansion I/O with STC6000

This chapter describes how to configure TM3 modules as local I/O expansion for STC6000.

This connection is supported by GP-Pro EX Ver.4.09.550 or later.

NOTE: When you use STC6000 as a replacement from LT3000, please refer to Chapter 11.

10.1 System configuration

10.1.1 Rear mounting

Max 2 units of TM3 modules can be connected on the rear of STC6000 series.

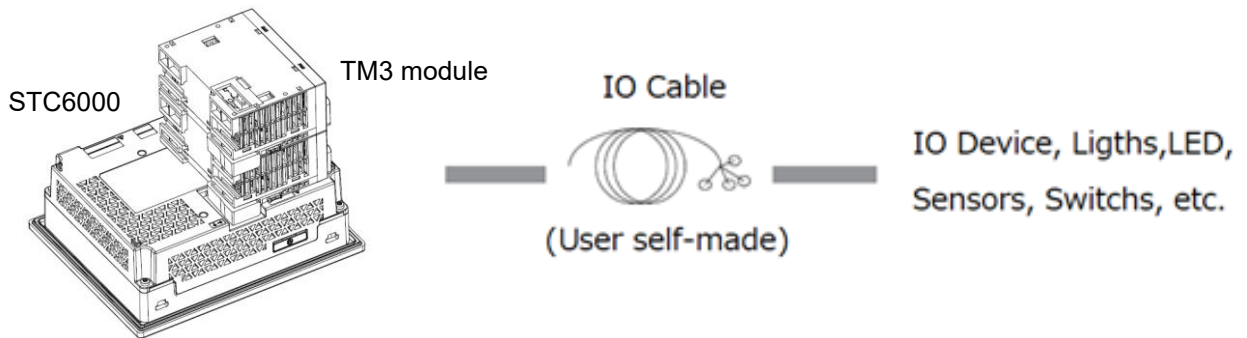

Series	Maximum number of connectable TM3 modules by Rear mounting
STC6000 Series	2 units

10.1.2 Extension mounting

To connect with more than 2 units of TM3 modules, extension mounting is available using TM3 Transmitter and Receiver modules.

- 7x TM3 modules can be connected at Receiver side.

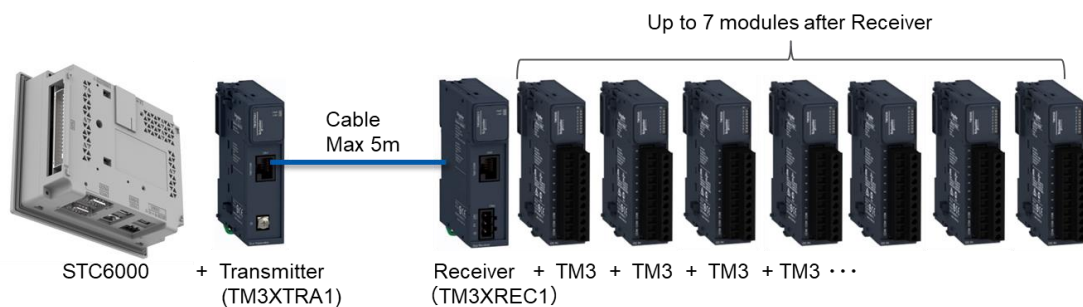

- If you want to connect 8x TM3 modules, please use the following configuration.

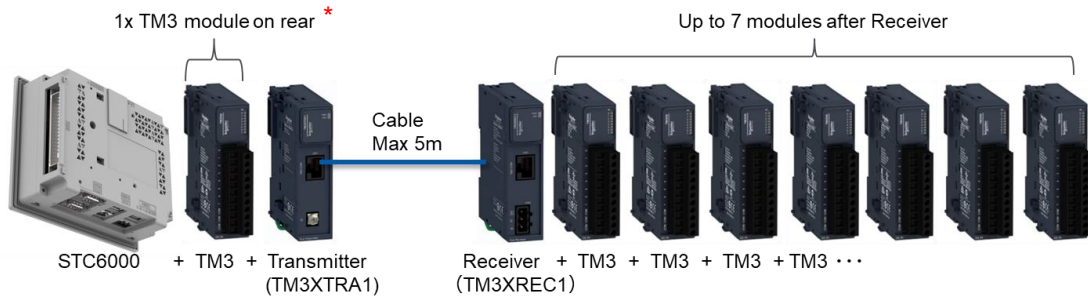

* When mounting one TM3 module and one transmitter module on the rear of STC6000 Series, mount TM3 module first, and then mount the transmitter module as a 2nd unit.

Series	Maximum number of connectable TM3 modules by Extension mounting
STC6000 Series	8 units (transmitter and receiver are not counted)

The following option items are required to connect TM3 modules by Extension mounting.

Reference	Description / Usage / Length etc.		
TM3XTRA1	Modicon TM3 Remote Transmitter Module		
TM3XREC1	Modicon TM3 Remote Receiver Module		
ACTPC6FULS05WE	Cat6 Patch Cord F/UTP LSZH, WHITE	Cable for connecting the Transmitter to the Receiver.	0.5m
ACTPC6FULS10WE			1m
ACTPC6FULS20WE			2m
ACTPC6FULS30WE			3m
ACTPC6FULS50WE			5m

NOTE:

- There's no setting required for the transmitter module and receiver module. (There are no configurable properties for these modules.)
- For connection using Transmitter and Receiver modules, please also refer to Modicon TM3 Transmitter and Receiver Modules Hardware Guide at se.com.

10.2 Connectable TM3 Modules by local I/O expansion

Type	TM3		
	Screw type	Spring type	HE10
Digital Input Module	TM3DI8	TM3DI8G	-
	TM3DI8A	-	
	TM3DI16	TM3DI16G	TM3DI16K
	-	-	TM3DI32K
Digital Output Module	TM3DQ8R	TM3DQ8RG	-
	TM3DQ16R	TM3DQ16RG	-
	TM3DQ8U	TM3DQ8UG	-
	TM3DQ8T	TM3DQ8TG	
	TM3DQ16U	TM3DQ16UG	TM3DQ16UK
	TM3DQ16T	TM3DQ16TG	TM3DQ16TK
	-	-	TM3DQ32UK *1
	-	-	TM3DQ32TK *1
Digital Input / Output Module	TM3DM8R	TM3DM8RG	-
	TM3DM24R	TM3DM24G	-
Analog Module	TM3AI2H	TM3AI2HG	-
	TM3AI4	TM3AI4G	-
	TM3TI4	TM3TI4G	-
	TM3TI4D	TM3TI4DG	-
	TM3AI8	TM3AI8G	
	TM3TI8T*3	TM3TI8TG*3	
	TM3AQ2	TM3AQ2G	
	TM3AQ4	TM3AQ4G	
	TM3TM3	TM3TM3G	
	TM3AM6	TM3AM6G	

*1 Only 1 unit of 32-point module can be connected to the rear of STC-6300TA. If you use 2 units or more, you need to connect by Extension mounting with Transmitter/Receiver modules.

*2 For TM3 Digital I/O modules, the functions supported after Firmware version 2 are not supported by TM3 Driver.

*3 TM3TI8T(G) is planned to be supported.

10.3 Installation Procedure

10.3.1 When connecting to STC6000 (Rear mounting)

1. Place the product face down on a clean, flat, level surface.
2. While pressing the “PUSH” mark on the expansion module interface cover, slide the cover towards the top of the product.

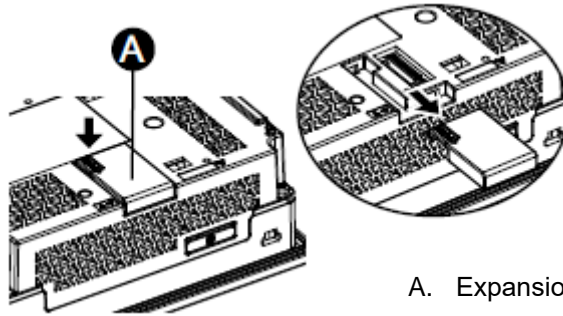

A. Expansion module interface cover

3. Insert the TM3 module's expansion connector into the expansion module interface.

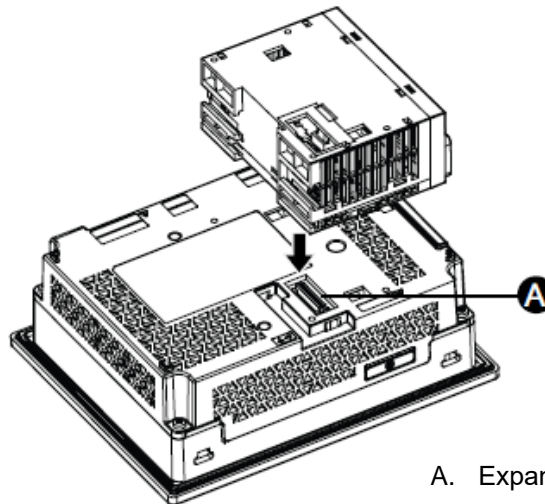

A. Expansion module interface

4. Push the locking device at the top of the TM3 module to secure the TM3 module.

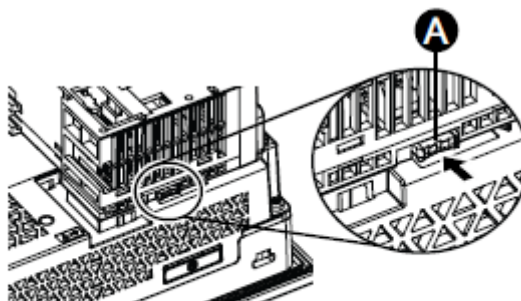

A. Locking device

5. Attach the TM3 module securing hook to the overlap between the TM3 module and this product. Hook the upper protrusion of the securing hook onto this product and the TM3 module, then push in the bottom part of the hook.

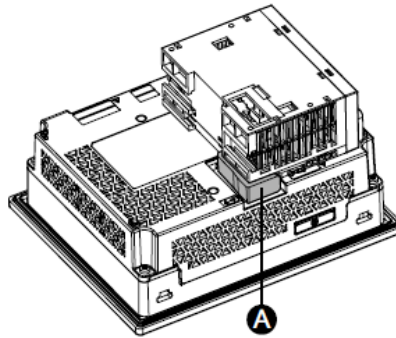

A. TM3 module securing hook

6. Attach the second TM3 module to the first TM3 module and secure them with the latch button in the same manner as described in step 4.

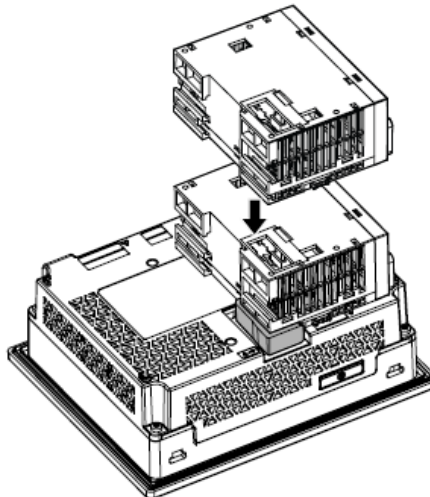

7. Attach the TM3 module securing hook to the overlap between the first and second TM3 modules in the same manner as described in step 5.

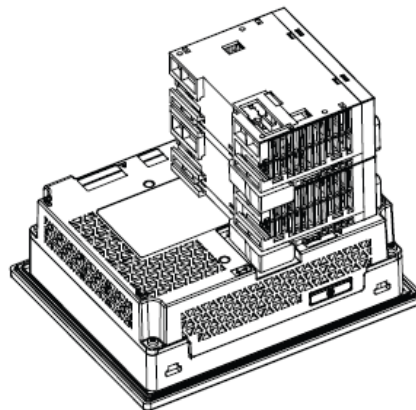

10.4 I/O Driver settings in GP-Pro EX

1. Select [STC6000 Series] for project model selection with GP-Pro EX.
Select [TM3 Driver] when selecting [I/O].

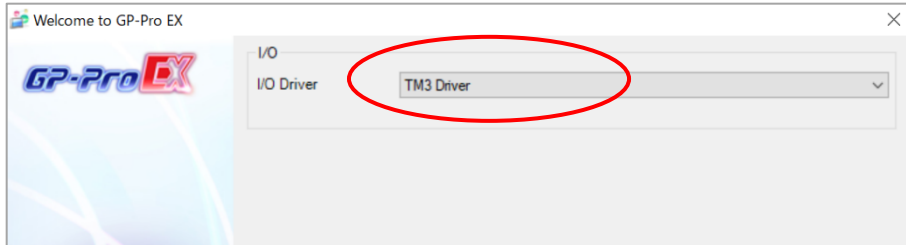

2. From the [Project] menu, click [System Settings] - [I/O Driver Settings] to open the [External Driver] tab.

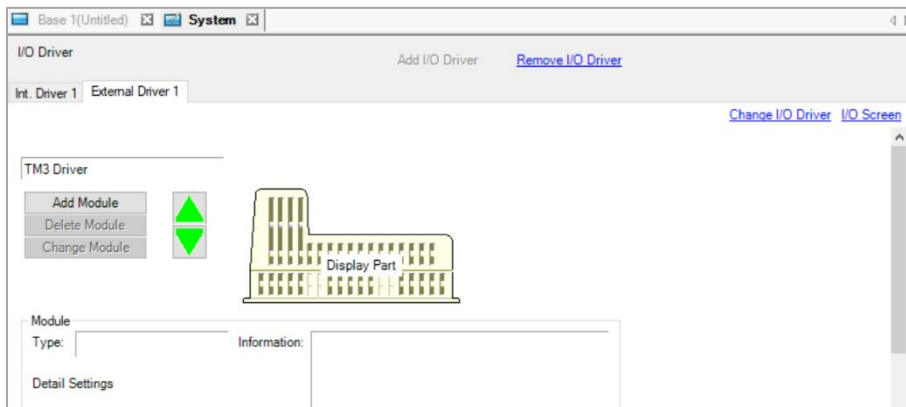

3. Click [Add Module] to display the [Module Details] window. Select a Model and click [OK].

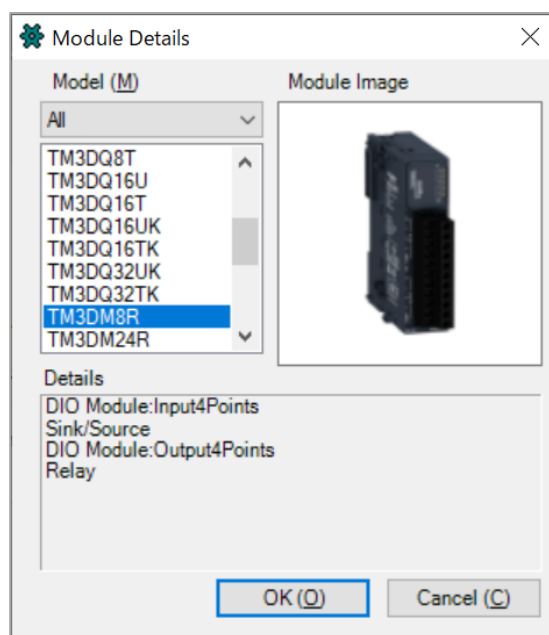

- The module-specific setting items are displayed. For the details, please refer to the manual of each TM3 module.

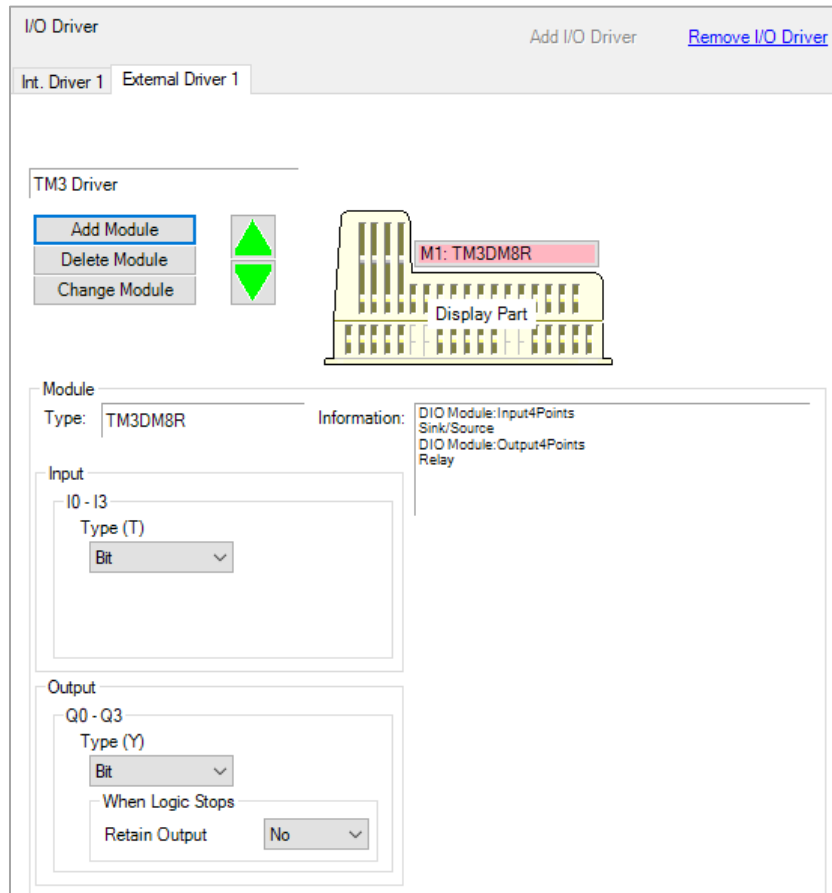

- Click [Add Module] to add a module. If you want to connect more than 2 units of TM3 modules, please select Transmitter.

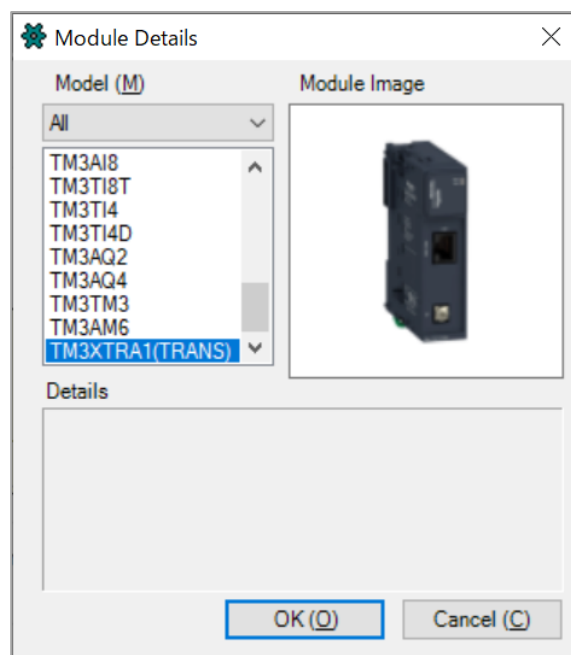

Transmitter module is added on the rear of the display part.

Receiver module is also displayed automatically.

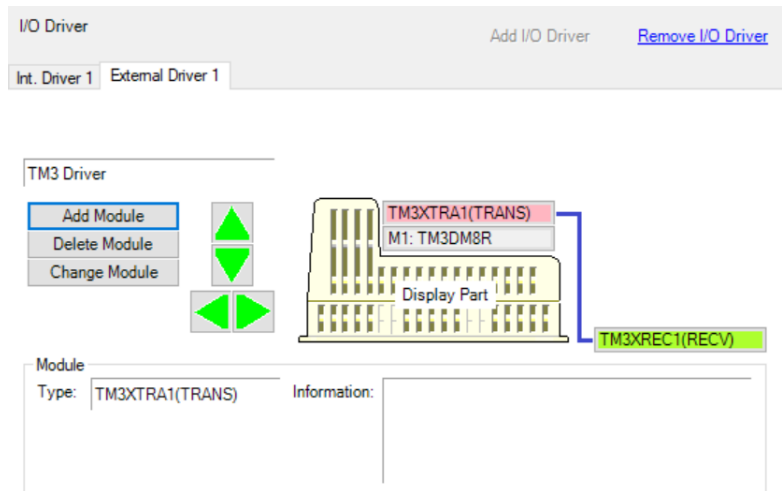

6. By [Add Module], [Delete Module] and [Change Module], you can add, delete, or change module.

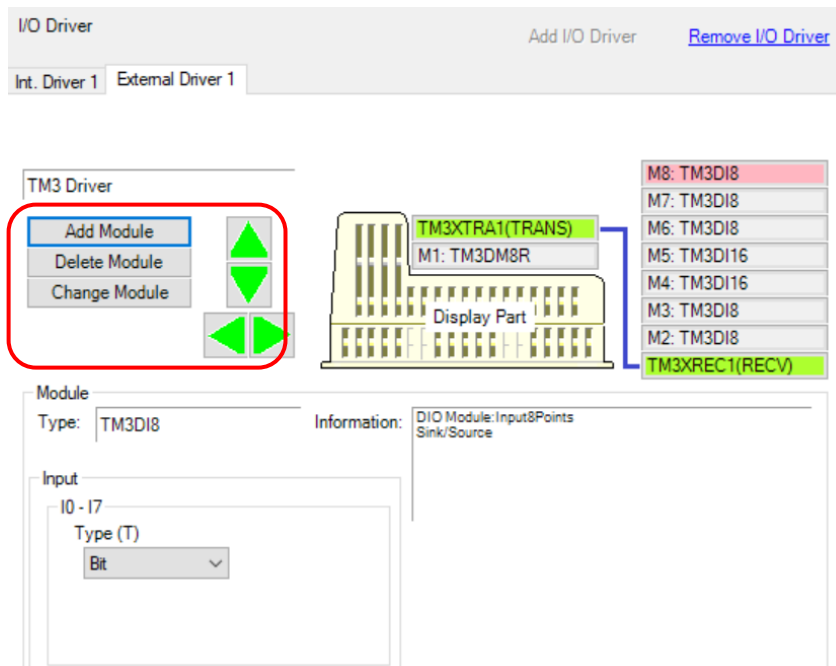

You can add up to 8 modules. If you click [Add Module] when 8 modules are already set, the following message will appear.

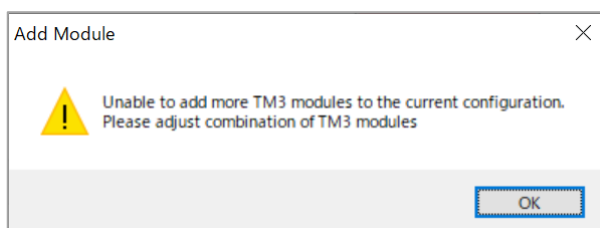

11 When using TM3 modules for local expansion I/O with LT3000 and STC6000 (when replacing from LT3000)

This chapter describes the TM3 module device configuration when mounted on the rear of LT3000/STC6000 (when replacing from LT3000). You can also mount EX module in the same way.

11.1 System configuration

LT3000/STC6000 series can connect the TM3 Modules directly on the back.

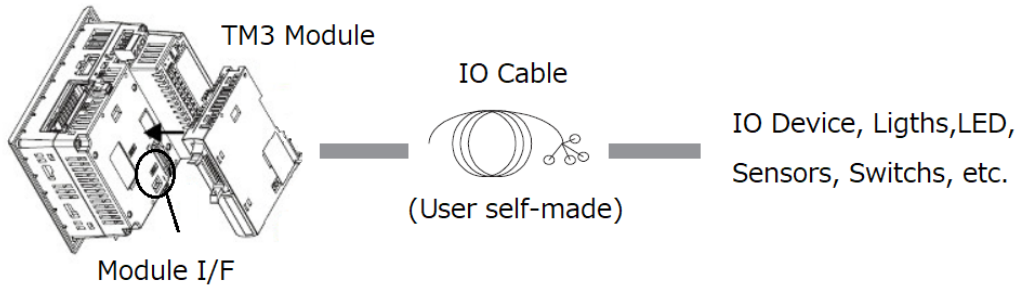

11.2 Connectable TM3 Modules

Type	TM3		
	Screw type	Spring type	HE10
Digital Input Module	TM3DI8	TM3DI8G	-
	TM3DI16	TM3DI16G	-
Digital Output Module	TM3DQ8R	TM3DQ8RG	-
	TM3DQ16R	TM3DQ16RG	-
	TM3DQ8U	TM3DQ8UG	-
	TM3DQ8T	TM3DQ8TG	
			TM3DQ16UK
			TM3DQ16TK
Digital Input / Output Module	TM3DM8R	TM3DM8RG	-
	TM3DM24R *2	TM3DM24G *2	-
Analog Module *1	TM3AI2H	TM3AI2HG	-
	TM3TI4	TM3TI4G	-
	TM3AQ2	TM3AQ2G	
	TM3TM3	TM3TM3G	
	TM3AM6	TM3AM6G	

*1 The Analog Modules can be mounted on the rear of LT3000 with GP-Pro EX V4.09.350 or later.

*2 As for TM3DM24R(G), only one TM3 module can be connected to LT-3300T/STC-6300TA.

11.3 Number of connectable modules on the rear of LT3000/STC6000

The number of TM3 modules that can be connected differs depending on the display or TM3 module type used. Please refer to the following table for details.

Series	Maximum number of connectable TM3 modules
LT-3200 Series	2 units *1
LT-3300 Series	3 units *1
STC6000 Series	2 units *1*2

*1 When connecting TM3DM24R(G), only 1 unit can be connected.

*2 3 units of TM3 modules can be connected by using the following option items.

The following option items are required to connect 3 units of TM3 modules to STC6000.

Reference	Description / Usage / Length etc.		
TM3XTRA1	Modicon TM3 Remote Transmitter Module		
TM3XREC1	Modicon TM3 Remote Receiver Module		
ACTPC6FULS05WE	Cat6 Patch Cord F/UTP LSZH, WHITE	Cable for connecting the Transmitter to the Receiver.	0.5m
ACTPC6FULS10WE			1m
ACTPC6FULS20WE			2m
ACTPC6FULS30WE			3m
ACTPC6FULS50WE			5m

11.4 In case of connecting 3 units of TM3/EX modules with STC6000

Please connect with one of the following configurations.

The transmitter and receiver modules are not counted in the number of connected units.

TM3 modules and EX modules can be used at the same time.

- When mounting Transmitter only on the back of STC6000:
You can connect max. 3 units of TM3/EX modules at Receiver side.

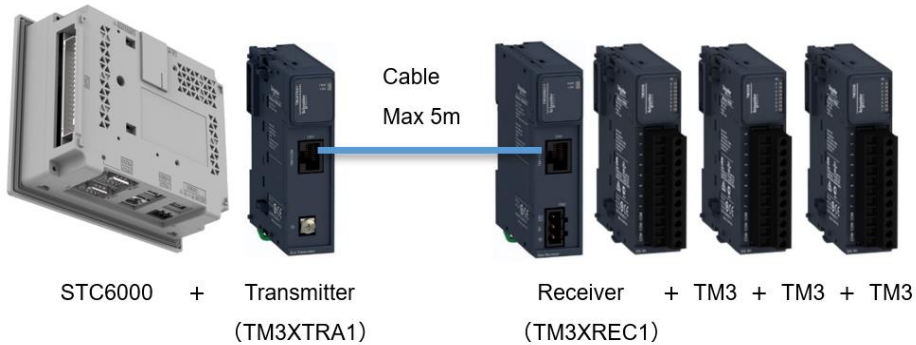

- When mounting one TM3/EX module and Transmitter on the back of STC6000:
You can connect max. 2 units of TM3/EX modules at Receiver side.

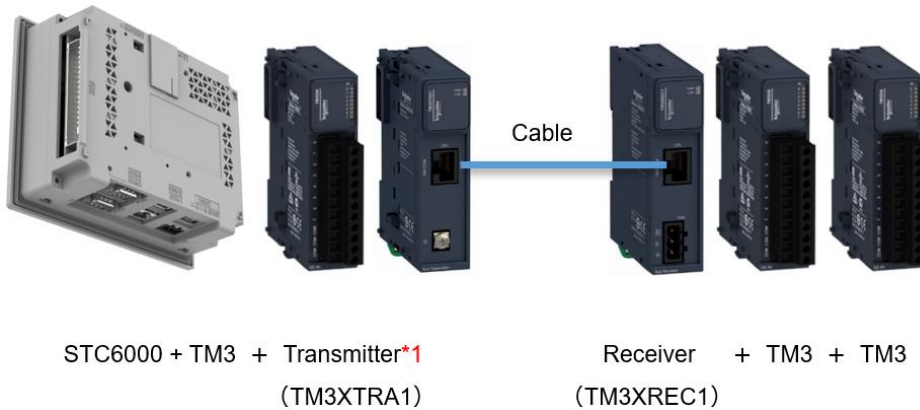

*1 When mounting one TM3 module and one transmitter module on the rear of STC6000 Series, mount TM3 module first, and then mount the transmitter module as a 2nd unit.

NOTE:

- There's no setting required for the transmitter module and receiver module. (There are no configurable properties for these modules.)
- For connection using Transmitter and Receiver modules, please also refer to Modicon TM3 Transmitter and Receiver Modules Hardware Guide at se.com.

11.5 Installation Procedure

11.5.1 When connecting to LT3000 (Rear Mounting)

1. Remove the seal on the module I/F on the back of the LT3000.

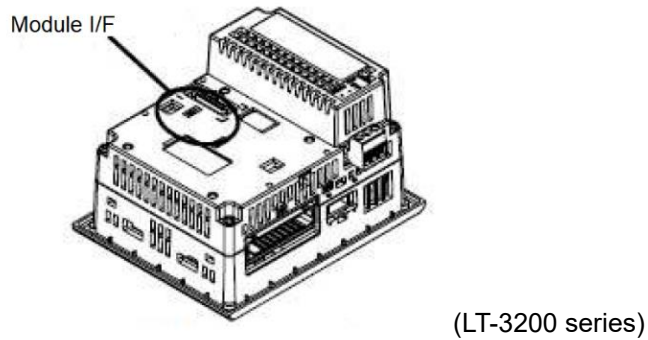

2. Attach TM3 to the back of LT3000. Insert the expansion connector on the left side of the first module into the module I/F of the LT3000. Install the second module in the same way.

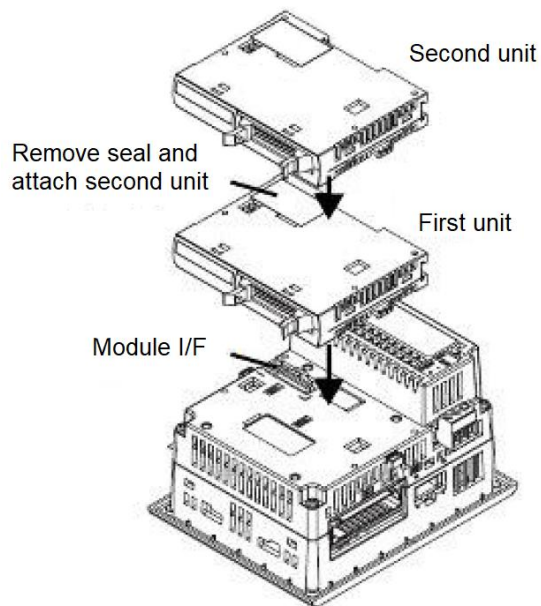

3. Push the latch button on the top to the bottom to secure it.

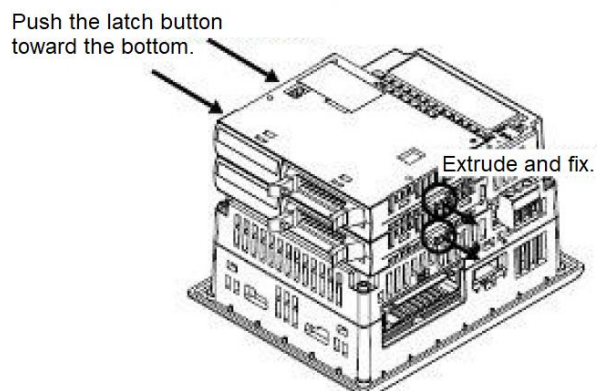

11.5.2 When connecting to STC6000 (Rear Mounting)

1. Place the product face down on a clean, flat, level surface.
2. While pressing the “PUSH” mark on the expansion module interface cover, slide the cover towards the top of the product.

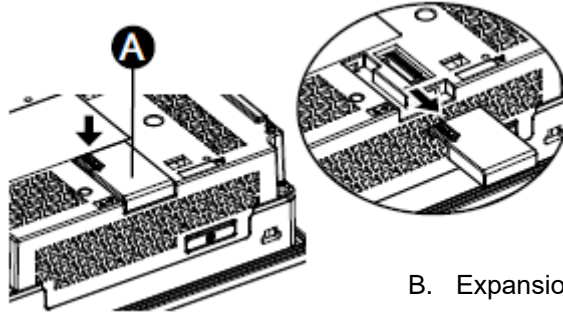

B. Expansion module interface cover

3. Insert the TM3 module's expansion connector into the expansion module interface.

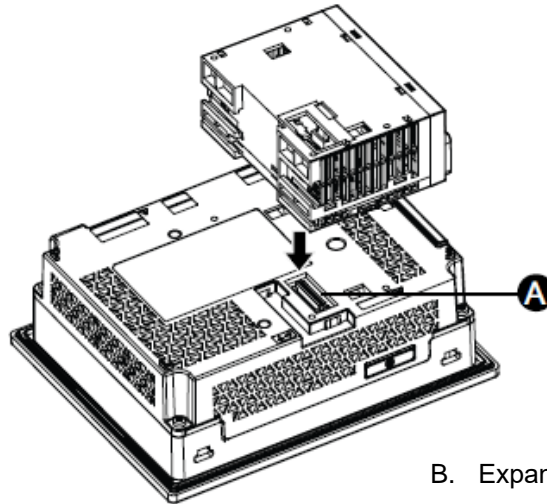

B. Expansion module interface

4. Push the locking device at the top of the TM3 module to secure the TM3 module.

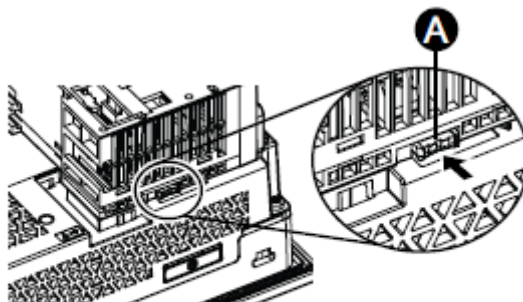

A. Locking device

5. Attach the TM3 module securing hook to the overlap between the TM3 module and this product. Hook the upper protrusion of the securing hook onto this product and the TM3 module, then push in the bottom part of the hook.

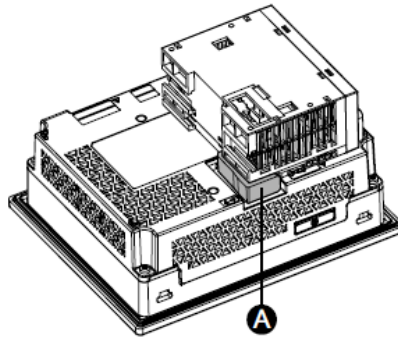

A. TM3 module securing hook

6. Attach the second TM3 module to the first TM3 module and secure them with the latch button in the same manner as described in step 4.

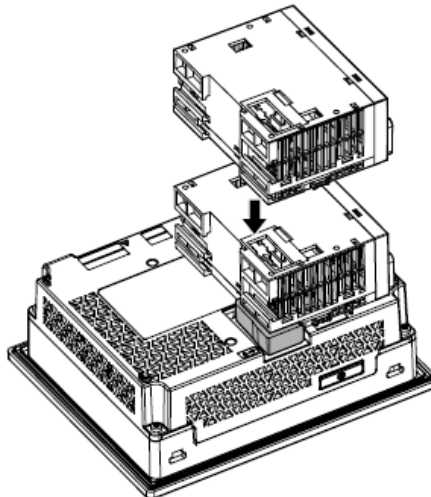

7. Attach the TM3 module securing hook to the overlap between the first and second TM3 modules in the same manner as described in step 5.

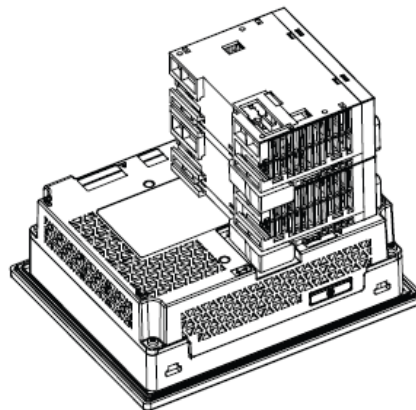

11.6 I/O Driver settings in GP-Pro EX

The setting method of between LT3000/STC6000 series and TM3 module is shown below.

The configuration of TM3 module in GP-Pro EX are the same as EX module.

1. Select the [LT3000 Series] or [STC6000 Series] for project model selection with GP-Pro EX. Select [EXM Driver] when selecting [I/O].

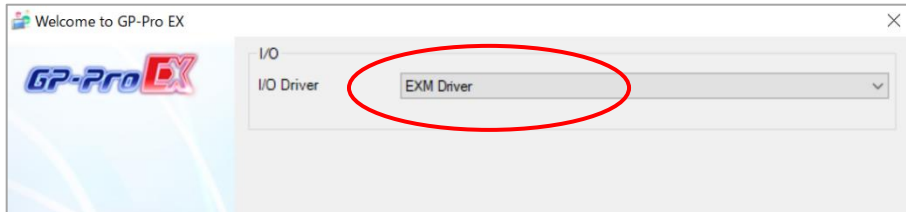

2. From the [Project] menu, click [System Settings] - [I / O Driver Settings] to open the [External Driver] tab.

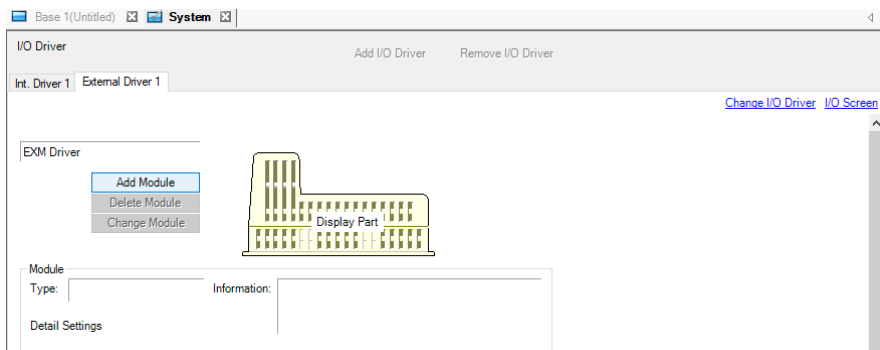

3. Click [Add module], display dialog of [module detail]. Select model of module and click [OK].

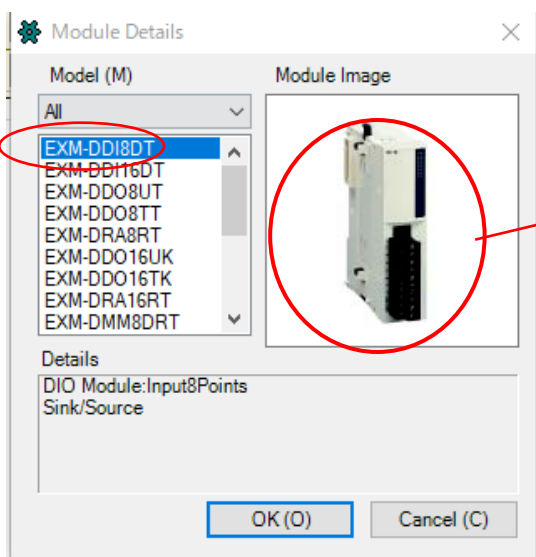

*1 The image of the editor and the appearance of the real product (TM3) are different. Please be careful when setting.

(Example) Display on GP-Pro EX

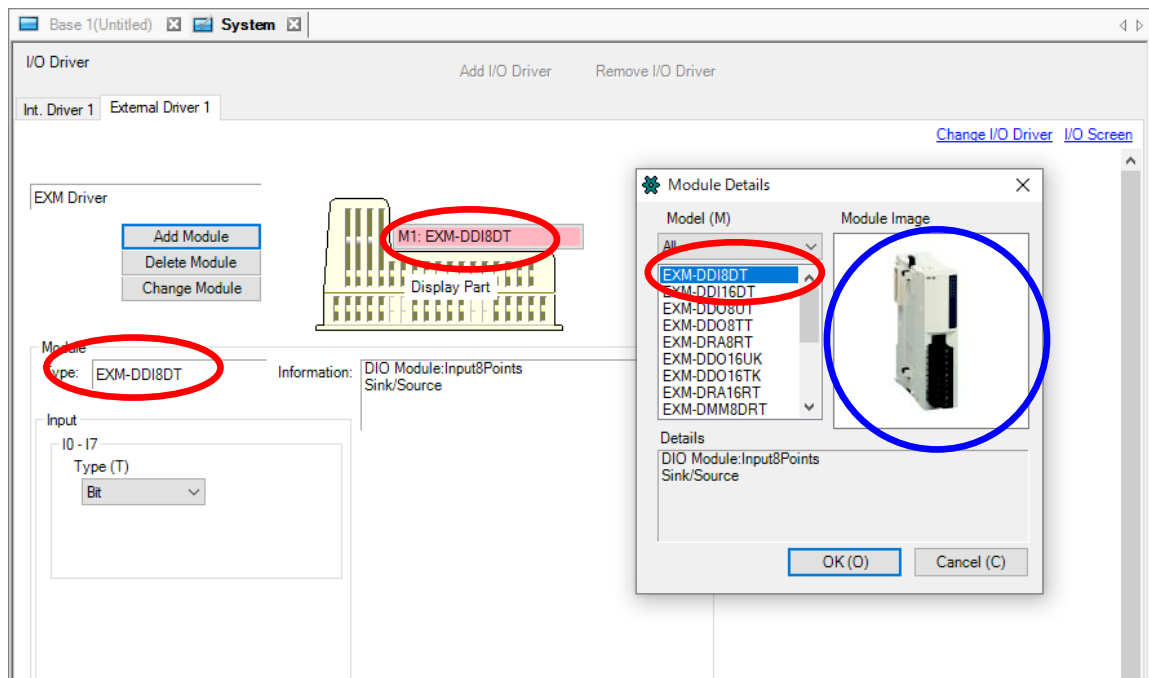

Only EX module models are displayed in GP-Pro EX..

Set the EX module model while comparing it with the TM3 model.

EX module	TM3 module	Functional difference
EXM-DDI8DT	TM3DI8	None
EXM-DDI16DT	TM3DI16	None
EXM-DRA8RT	TM3DQ8R	None
EXM-DRA16RT	TM3DQ16R	None
EXM-DDO8UT	TM3DQ8U	None
EXM-DDO16UK	TM3DQ16UK	None
EXM-DDO8TT	TM3DQ8T	None
EXM-DDO16TK	TM3DQ16TK	None
EXM-DMM8DRT	TM3DM8R	None
EXM-DMM24DRF	TM3DM24R	None
EXM-AMI2HT	TM3AI2H	None
EXM-ALM3LT	TM3TM3	Refer to 11.7.2
EXM-AMM3HT	TM3TM3	None
EXM-AMO1HT	TM3AQ2	Refer to 11.7.4
EXM-AMI4LT	TM3TI4	Refer to 11.7.5
EXM-AVO2HT	TM3AQ2	Refer to 11.7.6
EXM-AMM6HT	TM3AM6	None
EXM-ARI8LT	TM3TI4	Refer to 11.7.8

4. Module-specific setting items are displayed. See the configuration guide for each detail.

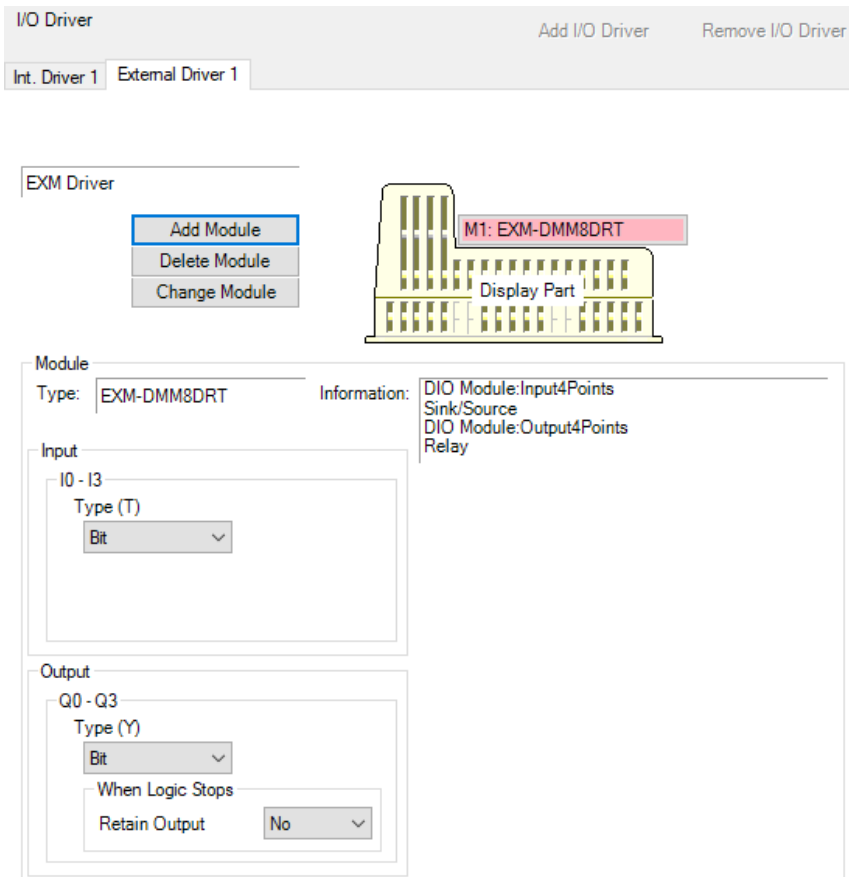

5. When to add, change and delete module, click on the module name and click the button below to change it.

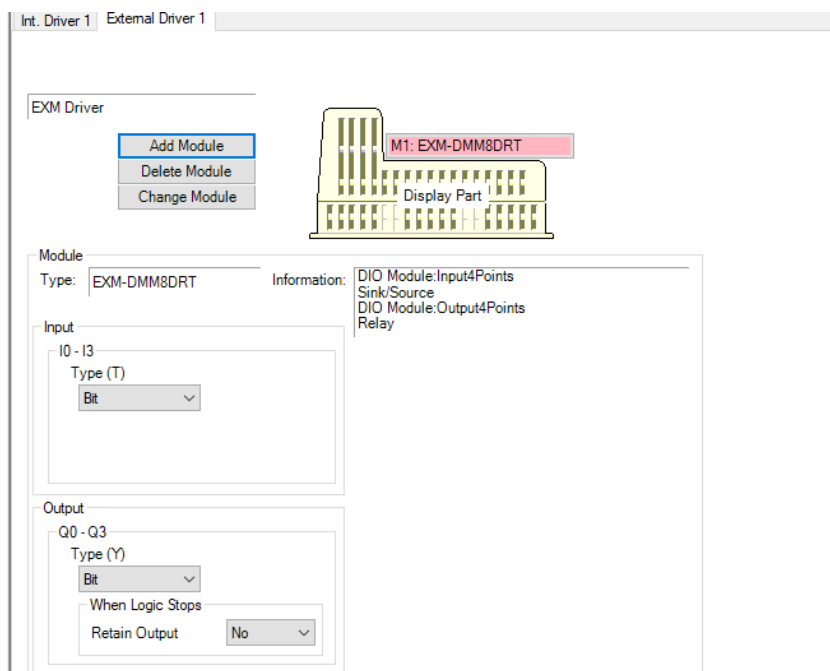

11.7 AIO module function difference (when mount on the rear of LT3000/STC6000)

There are some differences in function between analog modules of EX Module and TM3 Module.

The table below shows only the items with function difference.

Note: TM3 analog modules are supported by GP-Pro EX V4.09.350 or later version.

11.7.1 Specification Comparison of “EXM-AMI2HT” and “TM3AI2H / TM3AI2HG”

No functional difference.

11.7.2 Specification Comparison of “EXM-ALM3LT” and “TM3TM3 / TM3TM3G”

Function	EXM-ALM3LT	TM3TM3 (Screw) / TM3TM3G (Spring)
Input Voltage	-	DC 0 to 10V *1, (DC -10 to 10V *2)
Input Current	-	DC 4 to 20mA *1, (DC 0 to 20mA *2)
Thermocouple Type K	0 to 1300 °C	-200 to 1300 °C *1
Thermocouple Type J	0 to 1200 °C	-200 to 1000 °C *1
Thermocouple Type T	0 to 400 °C	-200 to 400 °C *1
Temperature PT100	-100 to 500 °C	-200 to 850 °C *1
Temperature PT1000	-	-200 to 600 °C *1
Temperature Ni100/Ni1000	-	-60 to 180 °C *1

*1 Items with functional differences

*2 This function and settings are not supported by GP-Pro EX.

11.7.3 Specification Comparison of “EXM-AMM3HT” and “TM3TM3 /TM3TM3G “

No functional difference.

11.7.4 Specification Comparison of “EXM-AMO1HT” and “TM3AQ2 / TM2AQ2G”

Function	EXM-AMO1HT	TM3AQ2 (Screw) /TM3AQ2 (Spring)
Channel	Output 1-point	Output 2-point *1

*1 Items with functional differences

11.7.5 Specification Comparison of “EXM-AMI4LT” and “TM3TI4 / TM3TI4G”

Function	EXM-AMI4LT	TM3TI4 (Screw) / TM3TI4G (Spring)
TemperaturePT100	-200 to 600 °C	-200 to 850 °C *1
Temperature Ni100/Ni1000	-50 to 150 °C	-60 to 180 °C *1

*1 Items with functional differences

11.7.6 Specification Comparison of “EXM-AVO2HT and “TM3AQ2 / TM3AQ2G”

Function	EXM-AVO2HT	TM3AQ2 (Screw) / TM3AQ2G (Spring)
Output Current	-	DC 4 to 20mA *1, (DC 0 to 20mA *2)

*1 Items with functional differences.

*2 This function and settings are not supported by GP-Pro EX.

11.7.7 Specification Comparison of “EXM-AMM6HT” and “TM3AM6 / TM3AM6G”

No functional difference.

11.7.8 Specification Comparison of “EXM-ARI8LT” and “TM3TI4 / TM3TI4G”

Function	EXM-ARI8LT	TM3TI4 x2 (Screw) / TM3TI4G x2 (Spring)
Channel	Input 8-point	Input 4-point *1 *3
Input Voltage	-	DC 0 to 10V *1, (DC -10 to 10V *2)
Input Current	-	DC 4 to 20mA *1, (DC 0 to 20mA *2)
Temperature PT100	-200 to 600 °C	-200 to 850 °C *1
Temperature PT1000	-50 to 200 °C	-200 to 600 °C *1
Temperature Ni100/Ni1000	-50 to 150 °C	-60 to 180 °C *1

*1 Items with functional differences.

*2 This function and settings are not supported by GP-Pro EX.

*3 Two units of TM3TI4 or TM3TI4G are required when using 5 channel or more.

11.8 DIO module comparison

11.8.1 Specification Comparison of EXM-DDI8T and TM3DI8

Reference	EXM-DDI8DT	TM3DI8
Description	Discrete input module,8 inputs 24 V DC,1 removable screw terminal	Discrete input module, Modicon TM3, 8 inputs (screw) 24 VDC
product or component type	Discrete input module	Discrete input module
discrete input number	8	8
discrete input voltage	24 V	24 V
discrete input voltage type	DC	DC
input voltage limits	20.4...28.8 V	15...28.8 V for input
discrete input logic	Sink or source	Sink or source (positive/negative)
discrete input current	7 mA	7 mA
input impedance	3.4 kOhm	3.4 kOhm
response time	4 ms at state 0 4 ms at state 1	4 ms (turn-off) 4 ms (turn-on)
isolation between channels	None	None
isolation between channels and internal logic	500 V for 1 minute	Between input and internal logic at 500 V AC. Non-insulated between inputs
current consumption	25 mA at 5 V DC at state 1 for all input	0 mA at 24 V DC via bus connector (at state off) 0 mA at 24 V DC via bus connector (at state on) 24 mA at 5 V DC via bus connector (at state on) 5 mA at 5 V DC via bus connector (at state off)
local signaling	1 display block	1 LED per channel (green) for input status
electrical connection	1 removable screw terminal block	11 x 2.5 mm ² removable screw terminal block with pitch 5.08 mm adjustment for inputs
mounting support	35 mm symmetrical DIN rail	plate or panel with fixing kit Top hat type TH35-15 rail conforming to IEC 60715 Top hat type TH35-7.5 rail conforming to IEC 60715
net weight	85 g	85 g
depth	70 mm	70 mm
height	90 mm	90 mm
width	23.5 mm	23.6 mm

11.8.2 Specification Comparison of EXM-DDI16DT and TM3DI16

Reference	EXM-DDI16DT	TM3DI16
Description	Discrete input module, Modicon M238 logic controller, 16 inputs 24 V DC, 1 removable screw terminal block	Discrete input module, Modicon TM3, 16 inputs (screw) 24 VDC
discrete input number	16	16 for input conforming to IEC 61131-2 type 3
discrete input logic	Sink or source	Sink or source (positive/negative)
discrete input voltage	24 V	24 V
discrete input current	7 mA for input	7 mA for input
discrete I/O number	16	16
current consumption	0 mA at 24 V DC via bus connector (at state off) 0 mA at 24 V DC via bus connector (at state on) 40 mA at 5 V DC via bus connector (at state on) 5 mA at 5 V DC via bus connector (at state off)	0 mA at 24 V DC via bus connector (at state off) 0 mA at 24 V DC via bus connector (at state on) 40 mA at 5 V DC via bus connector (at state on) 5 mA at 5 V DC via bus connector (at state off)
discrete input voltage type	DC	DC
voltage state 1 guaranteed	20.4...28.8 V	15...28.8 V for input
input impedance	3.4 kOhm	3.4 kOhm
response time	4 ms (turn-off) 4 ms (turn-on)	4 ms (turn-off) 4 ms (turn-on)
local Signaling	1 display block	1 LED per channel (green) for input status
electrical connection	1 removable screw terminal block	10 x 1.5 mm ² removable screw terminal block with pitch 3.81 mm adjustment for inputs
mounting support	35 mm symmetrical DIN rail	plate or panel with fixing kit Top hat type TH35-15 rail conforming to IEC 60715 Top hat type TH35-7.5 rail conforming to IEC 60715
net weight	100 g	100 g
depth	70 mm	70 mm
height	90 mm	90 mm
width	23.5 mm	23.6 mm

11.8.3 Specification Comparison of EXM-DRA8RT and TM3DQ8R

Reference	EXM-DRA8RT	TM3DQ8R
component type	Discrete output module	Discrete output module
discrete output type	Relay	Relay normally open
discrete output number	8	8
discrete output logic	1 NO	Positive or negative
discrete output voltage	24 V DC for relay output 240 V AC	24 V DC for relay output 240 V AC
discrete output current	2000 mA for relay output	2000 mA for relay output
discrete I/O number	8	8
current consumption	40 mA at 24 V DC at state 1 for all output 30 mA at 5 V DC at state 1 for all output	0 mA at 24 V DC via bus connector (at state off) 40 mA at 24 V DC via bus connector (at state on) 5 mA at 5 V DC via bus connector (at state off) 30 mA at 5 V DC via bus connector (at state on)
response time	<= 10 ms from state 0 to state 1 for input <= 5 ms from state 1 to state 0 for input	10 ms (turn-on) 5 ms (turn-off)
mechanical durability	20000000 cycles	20000000 cycles
minimum load	0.1 mA at 0.1 V DC	10 mA at 5 V DC for relay output
local Signaling	1 display block	1 LED per channel (green) for output status
electrical connection	1 removable screw terminal block	11 x 2.5 mm ² removable screw terminal block with pitch 5.08 mm adjustment for outputs
mounting support	35 mm symmetrical DIN rail	plate or panel with fixing kit Top hat type TH35-15 rail
net weight	110 g	110 g
depth	70 mm	70 mm
height	90 mm	90 mm
width	23.5 mm	23.6 mm

11.8.4 Specification Comparison of EXM-DDO8TT and TM3DQ8T

Reference	EXM-DDO8TT	TM3DQ8T
component type	Discrete output module	Discrete output module
discrete output type	Transistor	Transistor
discrete output number	8	8
discrete output logic	Source	Positive logic (source)
discrete output voltage	24 V DC transistor output	24 V DC transistor output
discrete output current	500 mA transistor output	500 mA transistor output
discrete I/O number	8	8
response time	450 μ s from state 0 to state 1 450 μ s from state 1 to state 0	450 μ s (turn-off) 450 μ s (turn-on)
maximum leakage current	0.1 mA	0.1 mA transistor output
maximum voltage drop	<0.4 V	<0.4 V
maximum tungsten load	12 W	<3 W transistor output
local Signaling	1 display block	for output status 1 LED per channel (green)
electrical connection	1 removable screw terminal block	11 x 2.5 mm ² removable screw terminal block pitch 5.08 mm for outputs
mounting support	35 mm symmetrical DIN rail	plate or panel with fixing kit
net weight	85 g	76 g
depth	70 mm	70 mm
height	90 mm	90 mm
width	23.5 mm	23.6 mm

11.8.5 Specification Comparison of EXM-DDO8UT and TM3DQ8U

Reference	EXM-DDO8UT	TM3DQ8U
component type	Discrete output module	Discrete output module
discrete output type	Transistor	Transistor
discrete output number	8	8
discrete output logic	Sink	Negative logic (sink)
discrete output voltage	24 V DC for transistor output	24 V DC for transistor output
discrete output current	50 mA for transistor output	50 mA for transistor output
discrete I/O number	8	8
current consumption	20 mA at 24 V DC at state 1 for all output 10 mA at 5 V DC at state 1 for all output	0 mA at 24 V DC via bus connector (at state off) 20 mA at 24 V DC via bus connector (at state on) 5 mA at 5 V DC via bus connector (at state off) 10 mA at 5 V DC via bus connector (at state on)
response time	300 μ s at state 0 300 μ s at state 1	450 μ s (turn-off) 450 μ s (turn-on)
local Signaling	1 display block	1 LED per channel (green) for output status
electrical connection	1 removable screw terminal block	11 x 2.5 mm ² removable screw terminal block with pitch 5.08 mm adjustment for outputs
insulation	none	Between output and internal logic at 500 V AC Non-insulated between outputs
marking	CE	CE
mounting support	35 mm symmetrical DIN rail	plate or panel with fixing kit
net weight	85 g	76 g
depth	70 mm	70 mm
height	90 mm	90 mm
width	23.5 mm	23.6 mm

11.8.6 Specification Comparison of EXM-DDO16TK and TM3DQ16TK

Reference	EXM-DDO16TK	TM3DQ16TK
component type	Discrete output module	Discrete output module
discrete output type	Transistor	Transistor
discrete output number	16	16
discrete output logic	Source	Positive logic (source)
discrete output voltage	24 V DC for transistor output	24 V DC for transistor output
discrete output current	16	100 mA for transistor output
discrete I/O number	16	16
current consumption	20 mA at 24 V DC at state 1 for all output 15 mA at 5 V DC at state 1 for all output	0 mA at 24 V DC via bus connector (at state off) 20 mA at 24 V DC via bus connector (at state on) 5 mA at 5 V DC via bus connector (at state off) 15 mA at 5 V DC via bus connector (at state on)
response time	450 μ s from state 0 to state 1 450 μ s from state 1 to state 0	450 μ s (turn-off) 450 μ s (turn-on)
maximum leakage current	0.1 mA	0.1 mA for transistor output
maximum voltage drop	1 V at state 1	<0.4 V
maximum tungsten load	9.6 W	<9.6 W for transistor output
local Signaling	2 display blocks	1 LED per channel (green) for output status
electrical connection	1 connector HE10	HE-10 connector for outputs
marking	CE	CE
mounting support	35 mm symmetrical DIN rail	plate or panel with fixing kit Top hat type TH35-15 rail conforming to IEC 60715 Top hat type TH35-7.5 rail conforming to IEC 60715
net weight	70 g	72 g
depth	70 mm	70 mm
height	90 mm	90 mm
width	17.6 mm	17.6 mm

11.8.7 Specification Comparison of EXM-DDO16UK and TM3DQ16UK

Reference	EXM-DDO16UK	TM3DQ16UK
component type	Discrete output module	Discrete output module
discrete output type	Transistor	Transistor
discrete output number	16	16
discrete output logic	Sink	Negative logic (sink)
discrete output voltage	24 V DC transistor output	24 V DC transistor output
discrete output current	100 mA transistor output	100 mA transistor output
discrete I/O number	16	16
current consumption	20 mA 24 V DC at state 1 for all output 10 mA 5 V DC at state 1 for all output	0 mA 24 V DC via bus connector at state off 20 mA 24 V DC via bus connector at state on 5 mA 5 V DC via bus connector at state off 15 mA 5 V DC via bus connector at state on
response time	300 μ s from state 0 to state 1 300 μ s from state 1 to state 0	450 μ s (turn-off) 450 μ s (turn-on)
maximum leakage current	0.12 A	0.1 mA transistor output
maximum voltage drops	1 V at state 1	<0.4 V
local signaling	2 display blocks	for output status 1 LED per channel (green)
electrical connection	1 connector HE10	HE-10 connector for outputs
marking	CE	CE
mounting support	35 mm symmetrical DIN rail	plate or panel with fixing kit Top hat type TH35-15 rail IEC 60715 Top hat type TH35-7.5 rail IEC 60715
net weight	70g	111 g
depth	70 mm	70 mm
height	90 mm	90 mm
width	17.6 mm	17.6 mm

11.8.8 Specification Comparison of EXM-DMM8DRT and TM3DM8R

Reference	EXM-DMM8DRT	TM3DM8R
component type	Discrete I/O module	Discrete I/O module
discrete input number	4	4 for input conforming to IEC 61131-2 Type 1
discrete input logic	Sink or source (positive/negative)	Sink or source (positive/negative)
discrete input voltage	24 V	24 V
discrete input current	7 mA	7 mA for input
discrete output type	Relay	Relay normally open
discrete output number	4	4
discrete output logic	Positive or negative	Positive or negative
discrete output voltage	24 V DC for relay output 240 V AC for relay output	24 V DC for relay output 240 V AC for relay output
discrete output current	2000 mA for relay output	2000 mA for relay output
discrete I/O number	8	8
current consumption	20 mA at 24 V DC at state 1 for all input/output 25 mA at 5 V DC at state 1 for all input/output	0 mA at 24 V DC via bus connector (at state off) 0 mA at 24 V DC via bus connector (at state on) 25 mA at 5 V DC via bus connector (at state on) 5 mA at 5 V DC via bus connector (at state off)
discrete input voltage type	DC	DC
voltage state 1 guaranteed	20.4...28.8 V	15...28.8 V for input
input impedance	3.4 kOhm	3.4 kOhm
response time	4 ms (turn-off) 4 ms (turn-on)	4 ms (turn-off) 4 ms (turn-on)
maximum current per output common	7 A	7 A
mechanical durability	20000000 cycles	20000000 cycles
minimum load	10 mA at 5 V DC for relay output	10 mA at 5 V DC for relay output
local Signaling	1 display block	1 LED per channel (green) for I/O state
electrical connection	1 removable screw terminal block	11 x 2.5 mm ² removable screw terminal block with pitch 5.08 mm adjustment for inputs and outputs
mounting support	35 mm symmetrical DIN rail	plate or panel with fixing kit Top hat type TH35-15 rail conforming to IEC 60715 Top hat type TH35-7.5 rail conforming to IEC 60715
net weight	95 g	95 g
Depth	70 mm	70 mm
Height	90 mm	90 mm
Width	23.5 mm	23.6 mm

11.8.9 Specification Comparison of EXM-DMM24DRT and TM3DM24R

Reference	EXM-DMM24DRF	TM3DM24R
product or component type	Discrete I/O module	Discrete I/O module
discrete input number	16	16 for input conforming to IEC 61131-2 Type 1
discrete input logic	Sink or Source	Sink or source (positive/negative)
discrete input voltage	24 V	24 V
discrete input current	7mA	7 mA for input
discrete output type	Relay	Relay normally open
discrete output number	8	8
discrete output logic	Positive or negative	Positive or negative
discrete output voltage	24 V DC for relay output 240 V AC for relay output	24 V DC for relay output 240 V AC for relay output
discrete output current	2000 mA for relay output	2000 mA for relay output
discrete I/O number	24	24
current consumption	45 mA at 24 V DC at state 1 for all input/output 65 mA at 5 V DC at state 1 for all input/output	0 mA at 24 V DC via bus connector (at state off) 0 mA at 24 V DC via bus connector (at state on) 5 mA at 5 V DC via bus connector (at state off) 65 mA at 5 V DC via bus connector (at state on)
discrete input voltage type	DC	DC
voltage state 1 guaranteed	20.4...28.8 V	15...28.8 V for input
input impedance	3.4 kOhm	3.4 kOhm
response time	4 ms at state 0 for input 4 ms at state 1 for input <= 10 ms from state 0 to state 1	4 ms (turn-off) 4 ms (turn-on)
maximum current per output common	7 A	7 A
mechanical durability	20000000 cycles	20000000 cycles
minimum load		10 mA at 5 V DC for relay output
local Signaling	1 display block	1 LED per channel (green) for I/O state
marking	CE	CE
mounting support	35 mm symmetrical DIN rail	plate or panel with fixing kit Top hat type TH35-15 rail conforming to IEC 60715 Top hat type TH35-7.5 rail conforming to IEC 60715
net weight	140 g	149 g
depth	70 mm	70 mm
height	90 mm	90 mm
width	39.1 mm	39.1 mm

12 TM3 Module Specification

12.1 Overview

The range of TM3 Digital I/O expansion modules includes:

- Input modules
- Output modules
- Mixed input/output modules

All TM3 Digital I/O expansion modules are equipped with (depending on the reference):

- Removable screw terminal blocks
- Removable spring terminal blocks
- HE10 (MIL 20) connectors

For modules with HE10 (MIL 20) connectors, a group of products known as Telefast 2 are available that enable these modules to be quickly connected to sensors and actuators.

The range of TM3 Analog I/O expansion modules includes:

- Input modules
- Output modules
- Mixed input/output modules

All TM3 Analog I/O expansion modules are equipped with (depending on the reference):

- Removable screw terminal blocks
- Removable spring terminal blocks

12.2 General Specification

12.2.1 Electrical specifications

TM3 Digital I/O Expansion Modules

Reference	CH	type	Voltage / currents	Terminal Type / Pitch
Digital Input Modules				
TM3DI8	8	Regular inputs	24 Vdc / 7 mA	Removable screw terminal block / 5.08 mm
TM3DI8G				Removable spring terminal block / 5.08 mm
TM3DI8A			120 Vac / 7.5 mA	Removable screw terminal block / 5.08 mm
TM3DI16	16		24 Vdc / 7 mA	Removable screw terminal block / 3.81 mm
TM3DI16G				Removable spring terminal block / 3.81 mm
TM3DI16K			24 Vdc / 5 mA	HE10 (MIL 20)
TM3DI32K	32			HE10 (MIL 20)
Digital Output Modules				
TM3DQ8R	8	Relay outputs	24 Vdc / 240 Vac	Removable screw terminal block / 5.08 mm
TM3DQ8RG			7A(common) / 2A (output)	Removable spring terminal block / 5.08 mm
TM3DQ16R	16		24 Vdc / 240V ac	Removable screw terminal block / 3.81 mm
TM3DQ16RG			8A(common) / 2A (output)	Removable spring terminal block / 3.81 mm
TM3DQ8U	8	Regular transistor outputs (sink)	24 Vdc / 240V ac	Removable screw terminal block / 5.08 mm
TM3DQ8UG			4A(common) / 0.5A (output)	Removable spring terminal block / 5.08 mm
TM3DQ8T		Regular transistor outputs (source)		Removable screw terminal block / 5.08 mm
TM3DQ8TG				Removable spring terminal block / 5.08 mm
TM3DQ16U	16	Regular transistor outputs (sink)	24 Vdc	Removable screw terminal block / 3.81 mm
TM3DQ16UG			8A(common) / 0.5A (output)	Removable spring terminal block / 3.81 mm
TM3DQ16UK			24 Vdc 2A(common) / 0.1A (output)	HE10 (MIL 20)
TM3DQ16T	16	Regular transistor outputs (source)	24 Vdc	Removable screw terminal block / 3.81 mm
TM3DQ16TG			8A(common) / 0.5A (output)	Removable spring terminal block / 3.81 mm
TM3DQ16TK			24 Vdc 2A(common) / 0.1A (output)	HE10 (MIL 20)
TM3DQ32UK	32	Regular transistor outputs (sink)	24 Vdc 2A(common) / 0.1A (出力)	HE10 (MIL 20)
TM3DQ32TK		Regular transistor outputs (source)		

Reference	CH	type	Voltage / currents	Terminal Type / Pitch
Digital Mixed Input/Output Modules				
TM3DM8R	4	Regular inputs	24 Vdc / 7 mA	Removable screw terminal block / 5.08 mm
	4	Relay outputs	24 Vdc / 240 Vac 7A (common) /2A (output)	
TM3DM8RG	4	Regular inputs	24 Vdc / 7 mA	Removable spring terminal block / 5.08 mm
	4	Relay outputs	24 Vdc / 240 Vac 7A (common) /2A (output)	
TM3DM24R	16	Regular inputs	24 Vdc / 7 mA	Removable screw terminal block / 3.81 mm
	8	Relay outputs	24 Vdc / 240 Vac 7A (common) /2A (output)	
TM3DM24RG	16	Regular inputs	24 Vdc / 7 mA	Removable spring terminal block / 3.81 mm
	8	Relay outputs	24 Vdc / 240V ac 7A (common) /2A (output)	

TM3 Analog I/O Expansion Modules

Reference	Resolution	Channels	Mode	Terminal Type / Pitch
Analog Input Module				
TM3AI2H	16bit, or 15bit + sign	Input: 2	0...10 Vdc	Removable screw terminal block / 5.08 mm
TM3AI2HG			-10...+10 Vdc 0...20 mA 4...20 mA	Removable spring terminal block / 5.08 mm
TM3AI4	12bit, or 11bit + sign	Input: 4	0...10 Vdc	Removable screw terminal block / 3.81 mm
TM3AI4G			-10...+10 Vdc 0...20 mA 4...20 mA	Removable spring terminal block / 3.81 mm
TM3TI4	16bit, or 15bit + sign	Input: 4	0...10 Vdc	Removable screw terminal block / 3.81 mm
TM3TI4G			-10...+10 Vdc 0...20 mA 4...20 mA Thermocouple PT100/1000 NI100/1000	Removable spring terminal block / 3.81 mm
TM3TI4D	16bit, or	Input: 4	Thermocouple	Removable screw terminal block / 3.81 mm
TM3TI4DG	15bit + sign			Removable spring terminal block / 3.81 mm

Reference	Resolution	Channels	Mode	Terminal Type / Pitch
TM3AI8	12bit, or 11bit + sign	Input: 8	0...10 Vdc	Removable screw terminal block / 3.81 mm
TM3AI8G			-10...+10 Vdc 0...20 mA 4...20 mA 0...20 mA extended 4...20 mA extended	Removable spring terminal block / 3.81 mm
TM3TI8T	16bit, or 15bit + sign	Input: 8	Thermocouple	Removable screw terminal block / 3.81 mm
TM3TI8TG			NTC/PTC Ohmmeter	Removable spring terminal block / 3.81 mm
Analog Output Module				
TM3AQ2	12bit, or 11bit + sign	Output: 2	0...10 Vdc	Removable screw terminal block / 5.08 mm
TM3AQ2G			-10...+10 Vdc	Removable spring terminal block / 5.08 mm
TM3AQ4		Output: 4	0...20 mA	Removable screw terminal block / 5.08 mm
TM3AQ4G			4...20 mA	Removable spring terminal block / 5.08 mm
Analog Input/Output Module				
TM3AM6 TM3AM6G	12bit, or 11bit + sign	Input:4	0...10 Vdc -10...+10 Vdc	TM3AM6: Removable screw terminal block / 3.81 mm
		Output:2	0...20 mA 4...20 mA	TM3AM6G: Removable spring terminal block / 3.81 mm
TM3TM3 TM3TM3G	16bit, or 15bit + sign	Input:2	0...10 Vdc -10...+10 Vdc 0...20 mA 4...20 mA Thermocouple PT100/1000 NI100/1000	TM3TM3: Removable screw terminal block / 5.08 mm TM3TM3G: Removable spring terminal block / 5.08 mm
	12bit, or 11bit + sign		Output:1	0...10 Vdc -10...+10 Vdc 0...20 mA 4...20 mA

12.2.2 Environmental specifications

Characteristic	Minimum Specification	Tested Range	
Standard compliance	IEC/EN 61131-2	-	
Ambient operating temperature	-	Horizontal installation	-10...55 °C (14...131 °F)
	-	Vertical installation	-10...35 °C (14...95 °F)
Storage temperature		-25...70 °C (- 13...158 °F)	
Relative humidity	-	Transport and storage	10...95 % (non-condensing)
	-	Operation	10...95 % (non-condensing)
Degree of pollution	IEC/EN 60664-1	2	
Degree of protection	IEC/EN 61131-2	IP20	
Corrosion immunity	-	Atmosphere free from corrosive gases	
Operating altitude	-	0...2000 m (0...6560 ft)	
Storage altitude	-	0...3000 m (0...9843 ft)	
Vibration resistance	IEC/EN 61131-2	Panel mounting or mounted on a top hat section rail (DIN rail)	10 mm (0.39 in) fixed amplitude from 5...8.7 Hz 29.4 m/s ² (96.45 ft/s ²) (3 gn) fixed acceleration from 8.7...150 Hz
Mechanical shock resistance	-	147 m/s ² or 482.28 ft/s ² (15 gn) for a duration of 11 ms	
<p>NOTE: The tested ranges may indicate values beyond that of the IEC Standard. However, our internal standards define what is necessary for industrial environments. In all cases, we uphold the minimum specification if indicated.</p>			

12.2.3 TWDFCW Cable**

Reference	Description	Details	Length
TWDFCW30K	Digital I/O cables with free wires for 20-pin Modular controller	Cable equipped at a one end with an HE10 connector. (AWG 22 / 0.34 mm ²).	3 m (9.84 ft)
TWDFCW50K			5 m (16.4 ft)

The following table provides specifications for the TWDFCW30K/50K with free wires for 20-pin connectors (HE10 or MIL20):

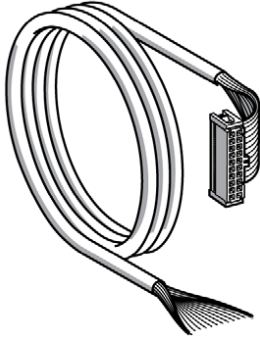
Cable illustration	Pin Connector	Wire Color
	1	White
	2	Brown
	3	Green
	4	Yellow
	5	Grey
	6	Pink
	7	Blue
	8	Red
	9	Black
	10	Violet
	11	Grey and Pink
	12	Red and blue
	13	White and green
	14	Brown and green
	15	White and yellow
	16	Yellow and brown
	17	White and grey
	18	Grey and brown
	19	White and pink
	20	Pink and brown

Telefast Pre-Wiring Sub-bases

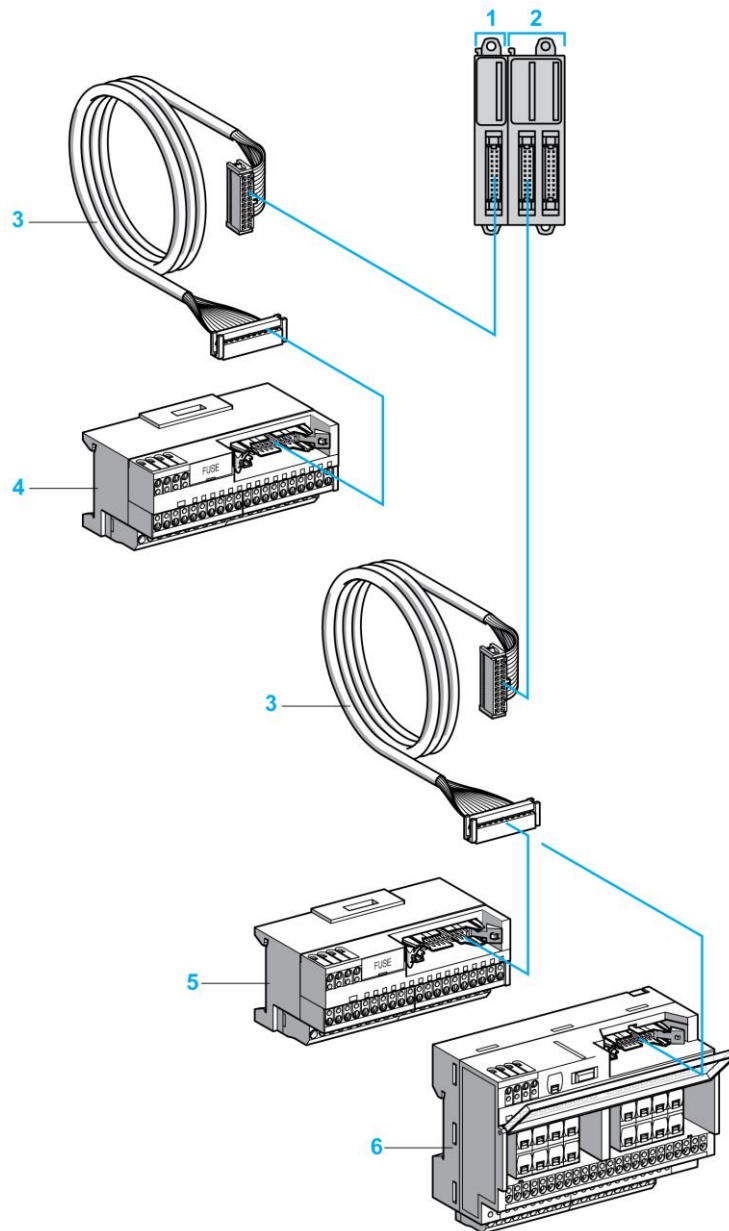

- 1 TM3DI16K / TM3DI32K
- 2 TM3DQ16TK / TM3DQ32TK
- 3 Cable equipped with a 20-way HE 10 connector at each end.
- 4 16 channel sub-base for input extension modules.
- 5-6 16 channel sub-base for output extension modules.

12.3 Digital Input Modules

12.3.1 TM3DI8 / TMDI8G

The table below describes the inputs characteristics of the TM3DI8 / TM3DI8G:

Characteristic		Value
Number of input channels		8 inputs
Number of channels groups		1 common line on three terminals for 8 channels
Input type		Type 1 (IEC/EN 61131-2)
Logic type		Sink/Source
Rated input voltage		24 Vdc
Input voltage range		19.2..28.8 Vdc
Rated input current		7 mA
Input impedance		3.4 kΩ
Turn on time		SV ^{*1} < 2.0: 4ms
Turn off time		SV ^{*1} ≥ 2.0: 100μs ^{*2}
Input limit values	Voltage at state 1	> 15 Vdc (15...28.8 Vdc)
	Voltage at state 0	< 5 Vdc (0...5 Vdc)
	Current at state 1	> 2.5 mA
	Current at state 0	<1 mA
Isolation	Between input and internal logic	500 Vac
	Between input groups	N/A
Connection type	TM3DI8	Removable screw terminal block
	TM3DI8G	Removable spring terminal block
Connector insertion/removal durability		Over 100 times
Current draw on 5 Vdc internal bus		22 mA (all inputs on)
		5 mA (all inputs off)
Current draw on 24 Vdc internal bus		0 mA (all inputs on)
		0 mA (all inputs off)
<p>^{*1} SV refers to the version and is printed on the product label.</p> <p>^{*2} The range depends on the configured filter value.</p>		

Dimension & Wiring Diagram (TM3DI8 / TM3DI8G)

<p>Dimensions</p> <p>mm in.</p> <p>LED</p> <p>Connector</p>	<p>LED</p>	<p>Color Green</p>
	<p>Connector</p>	<p>Status LED</p> <p>On: Activated Off: Disactivated</p>
<p>The 24 Vdc power supplies must be rated at least Protective Extra Low Voltage (PELV) according to IEC 61140. These power supplies are isolated between the electrical input and output circuits of the power supply.</p>		

12.3.2 TM3DI8A

The table below describes the inputs characteristics of the TM3DI8A expansion module:

Characteristic		Value
Number of input channels		8 inputs
Number of channels groups		2 common lines of 4 channels each
Input type		Type 1 (IEC/EN 61131-2))
Logic type		N/A
Rated input voltage		120 Vac
Input voltage range		0...132 Vac
Rated input current		7.5 mA at 100 Vac
Input impedance		11 kΩ
Turn on time		25 ms
De-rating	-10...55 °C (14...131 °F)	No de-rating
Input limit values	Voltage at state 1	> 79 Vac (79...132 Vac)
	Voltage at state 0	< 20 Vac (0...20 Vac)
	Current at state 1	2 mA < I < 15 mA
Isolation	Between input and internal logic	1500 Vac
	Between input groups	1500 Vac
Connector type		Removable screw terminal block
Connector insertion/removal durability		Over 100 times
Current draw on 5 Vdc internal bus		60 mA (all inputs on)
		25 mA (all inputs off)
Current draw on 24 Vdc internal bus		0 mA (all inputs on)
		0 mA (all inputs off)

Dimension & Wiring Diagram (TM3DI8A)

<p>Dimensions</p> <p>mm in.</p> <p>14,6 0,57</p> <p>70 2,76</p> <p>3,8 0,15</p> <p>23,6 0,93</p> <p>90 3,54</p> <p>5* 0,20</p> <p>LED</p> <p>Connector</p>	<p>LED</p>	<table border="1"> <tr> <td>Color</td> <td>Green</td> </tr> <tr> <td colspan="2">Status LED</td> </tr> <tr> <td colspan="2">On: Activated</td> </tr> <tr> <td colspan="2">Off: Disactivated</td> </tr> </table>	Color	Green	Status LED		On: Activated		Off: Disactivated	
	Color	Green								
Status LED										
On: Activated										
Off: Disactivated										
<p>Connector</p>	<p>The COM0 and COM1 terminal are not connected internally.</p>									
<p>Do not connect wires to unused terminals and/or terminals indicated as "No Connection (N.C.)".</p>										

12.3.3 TM3DI16 / TM3DI16G

The table below describes the inputs characteristics of the TM3DI16 / TM3DI16G:

Characteristic		Value
Number of input channels		16 inputs
Number of channels groups		1 common line on 4 terminals (2 per connector) for 16 channels
Input type		Type 1 (IEC/EN 61131-2)
Logic type		Sink/Source
Rated input voltage		24 Vdc
Input voltage range		19.2. 28.8 Vdc
Rated input current		7 mA
Input impedance		3.4 kΩ
Input limit values	Voltage at state 1	> 15 Vdc (15. 28.8 Vdc)
	Voltage at state 0	< 5 Vdc (0...5 Vdc)
	Current at state 1	> 2.5 mA
	Current at state 0	<1 mA
Turn on time		SV ^{*1} < 2.0: 4 ms
Turn off time		SV ^{*1} ≥ 2.0: 100 μs ^{*2}
Isolation	Between input and internal logic	500 Vac
	Between input groups	N/A
Connection type	TM3DI16	Removable screw terminal blocks
	TM3DI16G	Removable spring terminal blocks
Connector insertion/removal durability		Over 100 times
Current draw on 5 Vdc internal bus		34 mA (all inputs on) 5mA (all inputs off)
Current draw on 24 Vdc internal bus		0 mA (all inputs on) 0 mA (all inputs off)
<p>*1 SV refers to the version and is printed on the product label.</p> <p>*2 The range depends on the configured filter value.</p>		

Dimension & Wiring Diagram (TM3DI16 / TM3DI16G)

<p>Dimensions</p> <p>mm in.</p>	<p>LED</p>	<table border="1"> <tr> <th>Color</th> <th>Green</th> </tr> <tr> <td colspan="2">Status LED</td> </tr> <tr> <td colspan="2">On: Activated</td> </tr> <tr> <td colspan="2">Off: Disactivated</td> </tr> </table>	Color	Green	Status LED		On: Activated		Off: Disactivated	
	Color	Green								
Status LED										
On: Activated										
Off: Disactivated										
<p>Connector</p>	<p>The 4 COM terminals are connected internally.</p> <p>A Sink wiring (positive logic)</p> <p>B Source wiring (negative logic)</p>									

The 24 Vdc power supplies must be rated at least Protective Extra Low Voltage (PELV) according to IEC 61140. These power supplies are isolated between the electrical input and output circuits of the power supply.

12.3.4 TM3DI16K

The table below describes the inputs characteristics of the TM3DI16K:

Characteristic		Value
Number of input channels		16 inputs
Number of channels groups		1 common line on 2 pins for 16 channels
Input type		Type 1 (IEC/EN 61131-2)
Logic type		Sink/Source
Rated input voltage		24 Vdc
Input voltage range		19.2. 28.8 Vdc
Rated input current		5 mA
Input impedance		4.4 kΩ
Input limit values	Voltage at state 1	> 15 Vdc (15. 28.8 Vdc)
	Voltage at state 0	< 5 Vdc (0...5 Vdc)
	Current at state 1	> 2.5 mA
	Current at state 0	<1 mA
Turn on time		SV ^{*1} < 2.0: 4 ms
Turn off time		SV ^{*1} ≥ 2.0: 100 μs ^{*2}
Isolation	Between input and internal logic	500 Vac
	Between input groups	N/A
Connection type		HE10 (MIL 20) connector
Connector insertion/removal durability		Over 100 times
Current draw on 5 Vdc internal bus		34 mA (all inputs on)
		5 mA (all inputs off)
Current draw on 24 Vdc internal bus		0 mA (all inputs on)
		0 mA (all inputs off)
*1 SV refers to the version and is printed on the product label.		
*2 The range depends on the configured filter value.		

Dimension & Wiring Diagram (TM3DI16K)

<p>Dimensions</p>	<p>LED</p>	<table border="1"> <tr> <th>Color</th> <td>Green</td> </tr> <tr> <th>Status LED</th> <td>On: Activated Off: Disactivated</td> </tr> </table>	Color	Green	Status LED	On: Activated Off: Disactivated
Color	Green					
Status LED	On: Activated Off: Disactivated					
<p>Connector</p>	<p>The COM0 terminals are connected internally.</p> <p>A: Sink wiring (positive logic) B: Source wiring (negative logic)</p>					
<p>The 24 Vdc power supplies must be rated at least Protective Extra Low Voltage (PELV) according to IEC 61140. These power supplies are isolated between the electrical input and output circuits of the power supply. For more information on the cable color for TWDFCW30K/TWDFCW50K, refer to TWDFCW••K Cable Description.</p>						

12.3.5 TM3DI32K

The table below describes the inputs characteristics of the TM3DI32K:

Characteristic		Value
Number of input channels		32 inputs
Number of channels groups		2 groups of 16, 1 common line each on 2 pins
Input type		Type 1 (IEC/EN 61131-2)
Logic type		Sink/Source
Rated input voltage		24 Vdc
Input voltage range		19.2. 28.8 Vdc
Rated input current		5 mA
Input impedance		4.4 kΩ
Input limit values	Voltage at state 1	> 15 Vdc (15. 28.8 Vdc)
	Voltage at state 0	< 5 Vdc (0...5 Vdc)
	Current at state 1	> 2.5 mA
	Current at state 0	<1 mA
Turn on time		SV ^{*1} < 2.0: 4ms
Turn off time		SV ^{*1} ≥2.0: 100μs ^{*2}
Isolation	Between input and internal logic	500 Vac
	Between input groups	500 Vac
Connection type		HE10 (MIL 20) connectors
Connector insertion/removal durability		Over 100 times
Current draw on 5 Vdc internal bus		46 mA (all inputs on)
		5 mA (all inputs off)
Current draw on 24 Vdc internal bus		0 mA (all inputs on)
		0 mA (all inputs off)
<p>^{*1} SV refers to the version and is printed on the product label.</p> <p>^{*2} The range depends on the configured filter value.</p>		

Dimension & Wiring Diagram (TM3DI32K)

<p>Dimensions</p>	<p>LED</p>	<table border="1"> <tr> <td>Color</td> <td>Green</td> </tr> <tr> <td colspan="2">Status LED</td> </tr> <tr> <td colspan="2">On: Activated</td> </tr> <tr> <td colspan="2">Off: Disactivated</td> </tr> </table>	Color	Green	Status LED		On: Activated		Off: Disactivated	
Color	Green									
Status LED										
On: Activated										
Off: Disactivated										
<p>Connector</p>	<p>The COM0 and COM1 terminals are not connected internally.</p> <p>A: Sink wiring (positive logic) B: Source wiring (negative logic)</p>									
<p>The 24 Vdc power supplies must be rated at least Protective Extra Low Voltage (PELV) according to IEC 61140. These power supplies are isolated between the electrical input and output circuits of the power supply.</p> <p>For more information on the cable color for TWDFCW30K/TWDFCW50K, refer to TWDFCW••K Cable Description.</p>										

12.4 Digital Output Modules

12.4.1 TM3DQ8R / TM3DQ8RG

The table below describes the outputs characteristics of the TM3DQ8R / TM3DQ8RG:

Characteristic		Value
Number of output channels		8
Number of channel groups		2 common lines, one for each group of 4 channels
Output type		Relay
Contact type		NO (Normally Open)
Rated output voltage		24 Vdc, 240 Vac
Maximum voltage		30 Vdc, 264 Vac
Minimum switching load		5 Vdc at 10 mA
Rated output current		2 A
Maximum output current		2 A per output 7 A per common
Maximum output frequency with maximum load		20 operations per minute
Turn on time		Max. 10 ms
De-rating	-10...55 °C (14...131 °F)	No de-rating
Turn off time		Max. 10 ms
Contact resistance		30 mΩ max
Mechanical life		20 million operations
Electrical life	Under resistive load	See Power limitation in the next page
	Under inductive load	
Protection against short circuit		No
Isolation	Between output and internal logic	500 Vac
	Between channel groups	1500 Vac
Connection type	TM3DQ8R	Removable screw terminal block
	TM3DQ8RG	Removable spring terminal block
Connector insertion/removal durability		Over 100 times
Current draw on 5 Vdc internal bus		25 mA (all outputs on) 5 mA (all outputs off)
Current draw on 24 Vdc internal bus		40 mA (all outputs on) 0 mA (all outputs off)



- Power Limitation

This table describes the power limitations of the TM3DQ8R / TM3DQ8RG expansion module depending on the voltage, the type of load, and the number of operations required.

These expansion modules do not support capacitive loads.

Voltage	24 Vdc	120 Vac	240 Vac	Number of operations
Power of resistive loads	-	240 VA	480 VA	100,000
AC-12		80 VA	160 VA	300,000
Power of inductive loads	-	60 VA	120 VA	100,000
AC-15 ($\cos \phi = 0.35$)		18 VA	36 VA	300,000
Power of inductive loads	-	120 VA	240 VA	100,000
AC-14 ($\cos \phi = 0.7$)		36 VA	72 VA	300,000
Power of resistive loads	48W	-	-	100,000
DC-12	16W			300,000
Power of inductive loads	24W	-	-	100,000
DC-13 L/R = 7 ms	7.2W			300,000

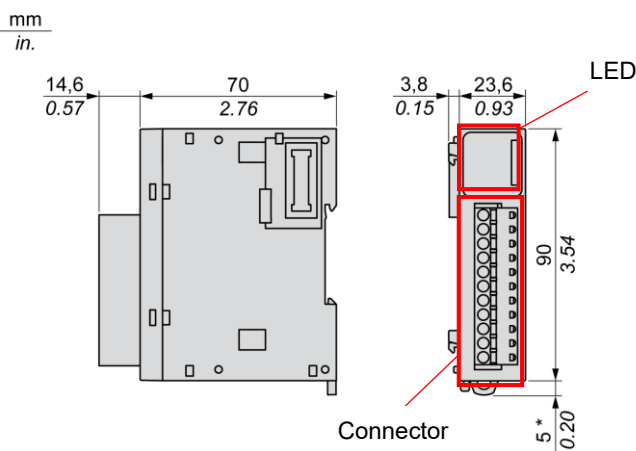
Dimension & wiring Diagram (TM3DQ8R / TM3DQ8RG)

<p>Dimensions</p> <p>$\frac{\text{mm}}{\text{in.}}$</p>  <p>14,6 / 0.57, 70 / 2.76, 3,8 / 0.15, 23,6 / 0.93, 90, 3,54, 5*, 0,20</p> <p>LED</p> <p>Connector</p>	<p>LED</p> 	<table border="1" style="width: 100%; border-collapse: collapse;"> <tr> <td style="width: 50%; text-align: center;">Color</td> <td style="width: 50%; text-align: center;">Green</td> </tr> <tr> <td colspan="2" style="text-align: center;">Status LED</td> </tr> <tr> <td colspan="2">On: Activated</td> </tr> <tr> <td colspan="2">Off: Disactivated</td> </tr> </table>	Color	Green	Status LED		On: Activated		Off: Disactivated	
Color	Green									
Status LED										
On: Activated										
Off: Disactivated										

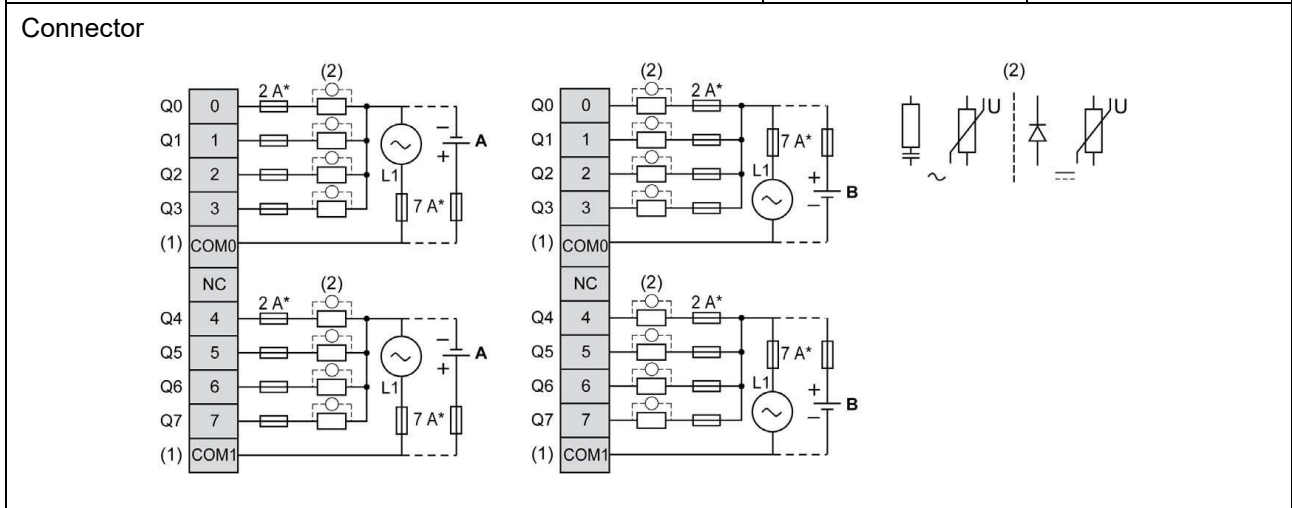

*Type T fuse

(1) The COM0 and COM1 terminals are not connected internally.

(2) To improve the lifetime of the contacts, and to protect from potential inductive load damage, connect a freewheeling diode in parallel to each inductive DC load or an RC snubber in parallel of each inductive AC load, or a varistor on either type of load.

A: Source wiring (positive logic)

B: Sink wiring (negative logic)

NOTE: When you use the TM3 expansion module with a TM3 Ethernet bus coupler, you must connect an RC snubber in parallel of each inductive AC load.

The 24 Vdc power supplies must be rated at least Protective Extra Low Voltage (PELV) according to IEC 61140. These power supplies are isolated between the electrical input and output circuits of the power supply.

Do not connect wires to unused terminals and/or terminals indicated as "No Connection (N.C.)".

12.4.2 TM3DQ16R / TM3DQ16RG

The table below describes the outputs characteristics of the TM3DQ16R / TM3DQ16RG:

Characteristic		Value
Number of output channels		8
Number of channel groups		2 common lines, one on 2 terminals for each group of 8 channels
Output type		Relay
Contact type		NO (Normally Open)
Rated output voltage		24 Vdc, 240 Vac
Maximum voltage		30 Vdc, 264 Vac
Minimum switching load		5 Vdc at 10 mA
Rated output current		2 A
Maximum output current		2 A per output
		8 A per common
Maximum output frequency	with maximum load	20 operations per minute
De-rating	-10...55 °C (14...131 °F)	No de-rating
Turn on time		Maximum 10 ms
Turn off time		Maximum 10 ms
Contact resistance		30 mΩ max
Mechanical life		20 million operations
Electrical life	Under resistive load	See Power limitation in the next page
	Under inductive load	
Protection against short circuit		No
Isolation	Between output and internal logic	500 Vac
	Between channel groups	1500 Vac
Connection type	TM3DQ16R	Removable screw terminal block
	TM3DQ16RG	Removable spring terminal block
Connector insertion/removal durability		Over 100 times
Current draw on 5 Vdc internal bus		37 mA (all outputs on), 5 mA (all outputs off)
Current draw on 24 Vdc internal bus		77 mA (all outputs on), 0 mA (all outputs off)

- Power Limitation

This table describes the power limitations of the TM3DQ16R / TM3DQ16RG expansion module depending on the voltage, the type of load, and the number of operations required.

These expansion modules do not support capacitive loads.

Voltage	24 Vdc	120 Vac	240 Vac	Number of operations
Power of resistive loads AC-12	-	240 VA 80 VA	480 VA 160 VA	100,000 300,000
Power of inductive loads AC-15 ($\cos \phi = 0.35$)	-	60 VA 18 VA	120 VA 36 VA	100,000 300,000
Power of inductive loads AC-14 ($\cos \phi = 0.7$)	-	120 VA 36 VA	240 VA 72 VA	100,000 300,000
Power of resistive loads DC-12	48W 16W	-	-	100,000 300,000
Power of inductive loads DC-13 L/R = 7 ms	24W 7.2W	-	-	100,000 300,000

Dimension & wiring Diagram (TM3DQ16R / TM3DQ16RG)

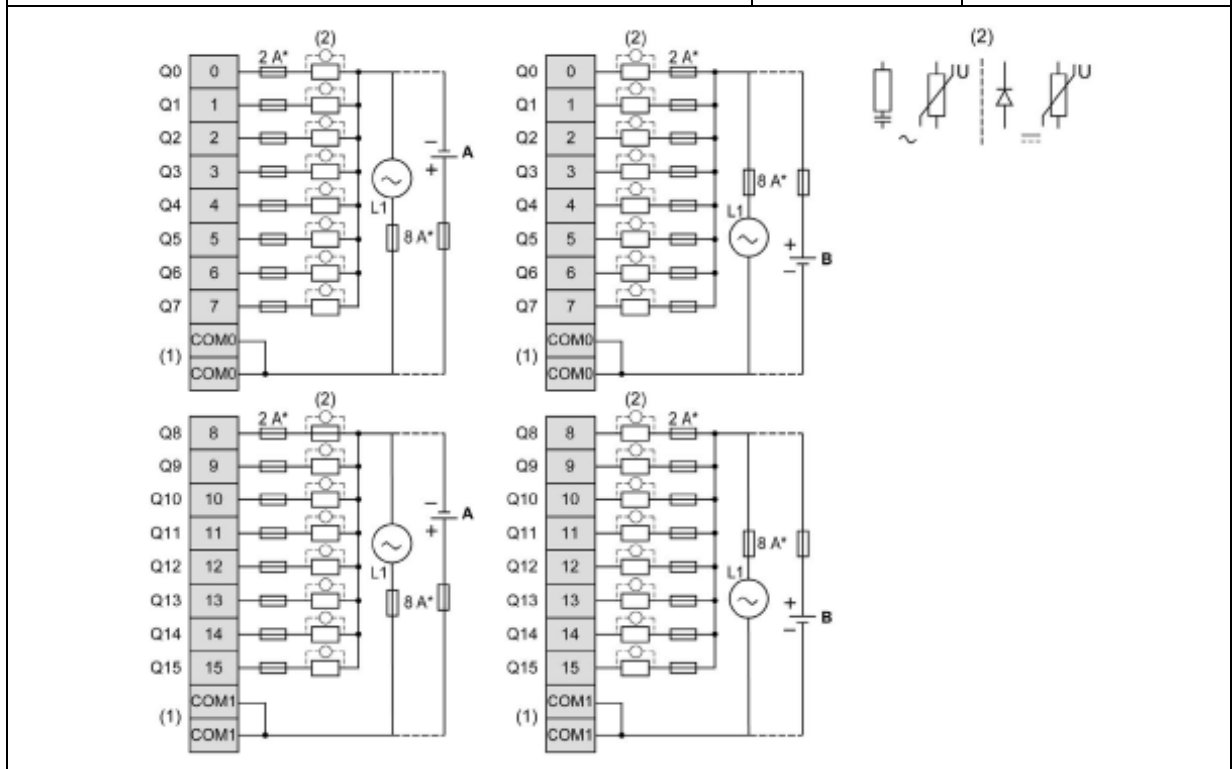
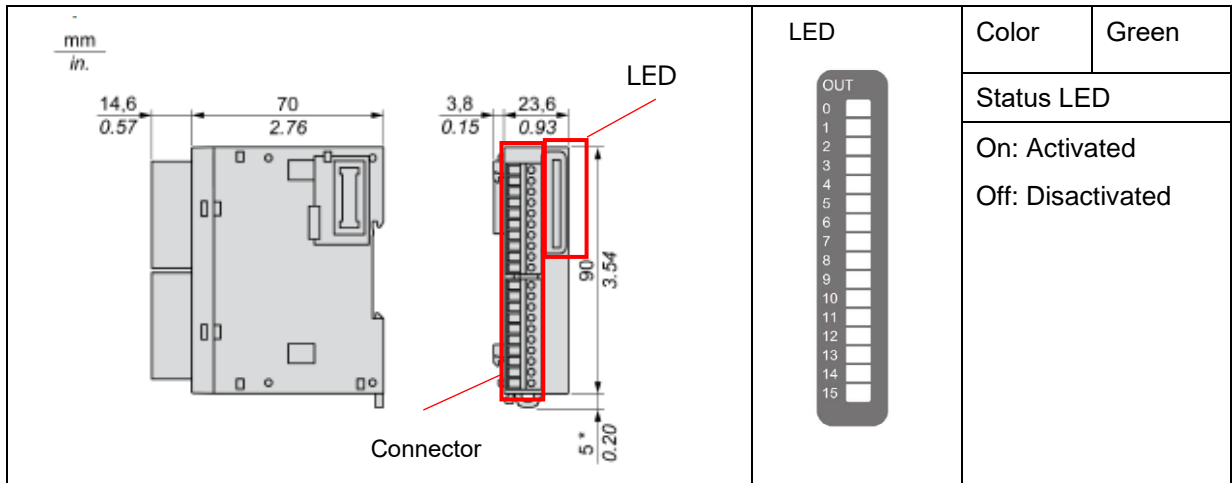

*Type T fuse

(1) The COM0 and COM1 terminals are not connected internally

(2) To improve the lifetime of the contacts, and to protect from potential inductive load damage, connect a freewheeling diode in parallel to each inductive DC load or an RC snubber in parallel of each inductive AC load, or a varistor on either type of load.

A Source wiring (positive logic)

B Sink wiring (negative logic)

NOTE: When you use the TM3 expansion module with a TM3 Ethernet bus coupler, you must connect and RC snubber in parallel of each inductive AC load.

The 24 Vdc power supplies must be rated at least Protective Extra Low Voltage (PELV) according to IEC 61140. These power supplies are isolated between the electrical input and output circuits of the power supply.

12.4.3 TM3DQ8U / TM3DQ8UG

The table below describes the outputs characteristics of the TM3DQ8U / TM3DQ8UG:

Characteristic		Value
Number of output channels		8
Number of channel groups		1 common line for 8 channels
Output type		Transistor
Logic type		Sink
Rated output voltage		24 Vdc
Output voltage range		19.2. 28.8 Vdc
Rated output current		0.5 A max. per channel
Total output current per group		4 A
Voltage drop		0.4 V max.
Leakage current when switched off		0.1 mA max.
Maximum power of filament lamp		12 W
Inductive load		L/R = 10 ms
De-rating	- 10...55 °C (14...131 °F)	No de-rating
Turn on time		450 µs
Turn off time		450 µs
Protection against short circuit		No (Fast external fuse required)
Short circuit output peak current		N/A
Automatic rearming after short circuit or overload		N/A
Protection against reverse polarity		No
Clamping voltage		Typically 50 Vdc
Switching frequency	Under resistive load	100 Hz max.
Isolation	Between output and internal logic	500 Vac
	Between channel group	N/A
Connection type	TM3DQ8U	Removable screw terminal block
	TM3DQ8UG	Removable spring terminal block
Connector insertion/removal durability		Over 100 times
Current draw on 5 Vdc internal bus		17 mA (all outputs on), 5 mA (all outputs off)
Current draw on 24 Vdc internal bus		8 mA (all outputs on), 0 mA (all outputs off)

Dimension & Wiring diagram (TM3DQ8U / TM3DQ8UG)

<p>Dimension</p> <p>mm in.</p>	<p>LED</p>	<table border="1"> <tr> <td>Color</td> <td>Green</td> </tr> <tr> <td colspan="2">Status LED</td> </tr> <tr> <td colspan="2">On: Activated</td> </tr> <tr> <td colspan="2">Off: Disactivated</td> </tr> </table>	Color	Green	Status LED		On: Activated		Off: Disactivated	
Color	Green									
Status LED										
On: Activated										
Off: Disactivated										
<p>Connector</p>	<p>* Type T fuse ** Type F fuse (1) The V- terminals are connected internally.</p>									
<p>The 24 Vdc power supplies must be rated at least Protective Extra Low Voltage (PELV) according to IEC 61140. These power supplies are isolated between the electrical input and output circuits of the power supply.</p>										

12.4.4 TM3DQ8T / TM3DQ8TG

The table below describes the outputs characteristics of the TM3DQ8T / TM3DQ8TG:

Characteristic		Value
Number of output channels		8
Number of channel groups		1 common line for 8 channels
Output type		Transistor
Logic type		Source
Rated output voltage		24 Vdc
Output voltage range		19.2. 28.8 Vdc
Rated output current		0.5 A max. per channel
Total output current per group		4 A
Voltage drop		0.4 Vdc max.
Leakage current when switched off		0.1 mA max.
Maximum power of filament lamp		12 W
Inductive load		L/R = 10 ms
De-rating	- 10...55 °C (14...131 °F)	No de-rating
Turn on time		450 µs
Turn off time		450 µs
Protection against short circuit		Yes
Short circuit output peak current		1 A typically
Automatic rearming after short circuit or overload		Yes, time depending on the expansion module temperature
Protection against reverse polarity		Yes
Clamping voltage		Typically 50 Vdc
Switching frequency	Under resistive load	100 Hz max.
Isolation	Between output and internal logic	500 Vac
	Between channel group	N/A
Connection type	TM3DQ8T	Removable screw terminal block
	TM3DQ8TG	Removable spring terminal block
Connector insertion/removal durability		Over 100 times
Current draw on 5 Vdc internal bus		17 mA (all outputs on), 5 mA (all outputs off)
Current draw on 24 Vdc internal bus		8 mA (all outputs on), 0 mA (all outputs off)

Dimension & Wiring Diagram (TM3DQ8T / TM3DQ8TG)

	<p>LED</p>	<table border="1"> <tr> <td>Color</td> <td>Green</td> </tr> <tr> <td colspan="2">Status LED</td> </tr> <tr> <td colspan="2">On: Activated</td> </tr> <tr> <td colspan="2">Off: Disactivated</td> </tr> </table>	Color	Green	Status LED		On: Activated		Off: Disactivated	
Color	Green									
Status LED										
On: Activated										
Off: Disactivated										
<p>Connector</p>	<p>* Type T fuse</p> <p>(1) The V+ terminals are connected internally.</p>									
<p>The 24 Vdc power supplies must be rated at least Protective Extra Low Voltage (PELV) according to IEC 61140. These power supplies are isolated between the electrical input and output circuits of the power supply.</p>										

12.4.5 TM3DQ16U / TM3DQ16UG

The table below describes the outputs characteristics of the TM3DQ16U and TM3DQ16UG:

Characteristic		Value
Number of output channels		16
Number of channel groups		1 common line on 2 pins for 16 channels
Output type		Transistor
Logic type		Sink
Rated output voltage		24 Vdc
Output voltage range		19.2. 28.8 Vdc
Rated output current		0.5 A
Total output current		8 A
Voltage drop		0.4 Vdc max.
Leakage current when switched off		0.1 mA max.
Maximum power of filament lamp		12 W
Inductive load		L/R = 10 ms
De-rating	- 10...55 °C (14...131 °F)	No de-rating
Turn on time		450 µs
Turn off time		450 µs
Protection against short circuit		No fast external fuse required
Short circuit output peak current		N/A
Automatic rearming after short circuit or overload		N/A
Protection against reverse polarity		No
Clamping voltage		Typically 50 Vdc
Switching frequency	Under resistive load	100 Hz max.
Isolation	Between output and internal logic	500 Vac
	Between channel group	N/A
Connection type	TM3DQ16U	Removable screw terminal blocks
	TM3DQ16UG	Removable spring terminal blocks
Connector insertion/removal durability		Over 100 times
Current draw on 5 Vdc internal bus		20 mA (all outputs on), 5 mA (all outputs off)
Current draw on 24 Vdc internal bus		16 mA (all outputs on), 0 mA (all outputs off)

Dimension & Wiring Diagram (TM3DQ16U/TM3DQ16UG)

<p>Dimensions</p> <p>mm in.</p> <p>LED</p> <p>Connector</p>	<p>LED</p> <p>TM3DQ16UK</p> <p>Schneider Electric</p> <p>OUT</p> <p>0</p> <p>1</p> <p>2</p> <p>3</p> <p>4</p> <p>5</p> <p>6</p> <p>7</p> <p>8</p> <p>9</p> <p>10</p> <p>11</p> <p>12</p> <p>13</p> <p>14</p> <p>15</p>	<table border="1"> <tr> <th>Color</th> <th>Green</th> </tr> <tr> <td colspan="2">Status LED</td> </tr> <tr> <td colspan="2">On: Activated</td> </tr> <tr> <td colspan="2">Off: Disactivated</td> </tr> </table>	Color	Green	Status LED		On: Activated		Off: Disactivated	
Color	Green									
Status LED										
On: Activated										
Off: Disactivated										
<p>Connector</p> <p>Q0 0</p> <p>Q1 1</p> <p>Q2 2</p> <p>Q3 3</p> <p>Q4 4</p> <p>Q5 5</p> <p>Q6 6</p> <p>Q7 7</p> <p>V-</p> <p>V+</p> <p>Q8 8</p> <p>Q9 9</p> <p>Q10 10</p> <p>Q11 11</p> <p>Q12 12</p> <p>Q13 13</p> <p>Q14 14</p> <p>Q15 15</p> <p>V-</p> <p>V+</p> <p>0.5 A*</p> <p>0.5 A*</p> <p>8 A**</p>	<p>* Type T fuse</p> <p>** Type F fuse</p>									
<p>The 24 Vdc power supplies must be rated at least Protective Extra Low Voltage (PELV) according to IEC 61140. These power supplies are isolated between the electrical input and output circuits of the power supply.</p>										

12.4.6 TM3DQ16UK

The table below describes the outputs characteristics of the TM3DQ16UK:

Characteristic		Value
Number of output channels		16
Number of channel groups		1 common line on 2 pins for 16 channels
Output type		Transistor
Logic type		Sink
Rated output voltage		24 Vdc
Output voltage range		19.2. 28.8 Vdc
Rated output current		0.1 A
Total output current per group		2 A
Voltage drop		0.4 Vdc max.
Leakage current when switched off		0.1 mA max.
Maximum power of filament lamp		2.4 W
Inductive load		L/R = 10 ms
De-rating	- 10...55 °C (14...131 °F)	No de-rating
Turn on time		450 µs
Turn off time		450 µs
Protection against short circuit		No, fast external fuse required
Short circuit output peak current		N/A
Automatic rearming after short circuit or overload		N/A
Protection against reverse polarity		No
Clamping voltage		Typically 50 Vdc
Switching frequency	Under resistive load	100 Hz max.
Isolation	Between output and internal logic	500 Vac
	Between channel group	N/A
Connection type		HE10 (MIL 20) connector
Connector insertion/removal durability		Over 100 times
Current draw on 5 Vdc internal bus		20 mA (all outputs on), 5 mA (all outputs off)
Current draw on 24 Vdc internal bus		16 mA (all outputs on), 0 mA (all outputs off)

Dimension & Wiring Diagram (TM3DQ16UK)

	<p>LED</p>	<table border="1"> <tr> <td>Color</td> <td>Green</td> </tr> <tr> <td colspan="2">Status LED</td> </tr> <tr> <td colspan="2">On: Activated</td> </tr> <tr> <td colspan="2">Off: Disactivated</td> </tr> </table>	Color	Green	Status LED		On: Activated		Off: Disactivated	
Color	Green									
Status LED										
On: Activated										
Off: Disactivated										
	<p>* Type T fuse ** Type F fuse</p>									
<p>The 24 Vdc power supplies must be rated at least Protective Extra Low Voltage (PELV) according to IEC 61140. These power supplies are isolated between the electrical input and output circuits of the power supply.</p>										

12.4.7 TM3DQ16T / TM3DQ16TG

The table below describes the outputs characteristics of the TM3DQ16T and TM3DQ16TG

Characteristic		Value
Number of output channels		16
Number of channel groups		1 common line on 2 terminals for 16 channels
Output type		Transistor
Logic type		Source
Rated output voltage		24 Vdc
Output voltage range		19.2. 28.8 Vdc
Rated output current		0.5 A
Total output current per group		8 A
Voltage drop		0.4 Vdc max.
Leakage current when switched off		0.1 mA max.
Maximum power of filament lamp		3 W
Inductive load		L/R = 10 ms
De-rating	- 10...55 °C (14...131 °F)	No de-rating
Turn on time		450 µs
Turn off time		450 µs
Protection against short circuit		Yes
Short circuit output peak current		1 A typically
Automatic rearming after short circuit or overload		Yes, time depending on component temperature
Protection against reverse polarity		Yes
Clamping voltage		Typically 50 Vdc
Switching frequency	Under resistive load	100 Hz max.
Isolation	Between output and internal logic	500 Vac
	Between channel group	N/A
Connection type	TM3DQ16T	Removable screw terminal blocks
	TM3DQ16TG	Removable spring terminal blocks
Connector insertion/removal durability		Over 100 times
Current draw on 5 Vdc internal bus		20 mA (all outputs on), 5 mA (all outputs off)
Current draw on 24 Vdc internal bus		16 mA (all outputs on), 0 mA (all outputs off)

Dimension & Wiring Diagram (TM3DQ16T / TM3DQ16TG)

<p>mm in.</p> <p>14,6 0.57</p> <p>70 2.76</p> <p>3,8 0.15</p> <p>23,6 0.93</p> <p>90 3.54</p> <p>5* 0.20</p> <p>LED</p> <p>Connector</p>	<p>LED</p> <p>OUT</p> <p>0</p> <p>1</p> <p>2</p> <p>3</p> <p>4</p> <p>5</p> <p>6</p> <p>7</p> <p>8</p> <p>9</p> <p>10</p> <p>11</p> <p>12</p> <p>13</p> <p>14</p> <p>15</p>	<table border="1"> <tr> <th>Color</th> <td>Green</td> </tr> <tr> <th>Status LED</th> <td></td> </tr> <tr> <td>On: Activated</td> <td></td> </tr> <tr> <td>Off: Disactivated</td> <td></td> </tr> </table>	Color	Green	Status LED		On: Activated		Off: Disactivated	
Color	Green									
Status LED										
On: Activated										
Off: Disactivated										
<p>Q0 0</p> <p>Q1 1</p> <p>Q2 2</p> <p>Q3 3</p> <p>Q4 4</p> <p>Q5 5</p> <p>Q6 6</p> <p>Q7 7</p> <p>V+</p> <p>V-</p> <p>Q8 8</p> <p>Q9 9</p> <p>Q10 10</p> <p>Q11 11</p> <p>Q12 12</p> <p>Q13 13</p> <p>Q14 14</p> <p>Q15 15</p> <p>V+</p> <p>V-</p> <p>8 A*</p>	<p>* Type T Fuse</p>									
<p>The 24 Vdc power supplies must be rated at least Protective Extra Low Voltage (PELV) according to IEC 61140. These power supplies are isolated between the electrical input and output circuits of the power supply.</p> <p>For more information on the cable color for TWDFCW30K/TWDFCW50K, refer to TWDFCW**K Cable Description.</p>										

12.4.8 TM3DQ16TK

The table below describes the outputs characteristics of the TM3DQ16TK:

Characteristic		Value
Number of output channels		16
Number of channel groups		1 common line on 2 pins for 16 channels
Output type		Transistor
Logic type		Source
Rated output voltage		24 Vdc
Output voltage range		19.2. 28.8 Vdc
Rated output current		0.1 A max. per channel
Total output current per group		2 A
Voltage drop		0.4 Vdc max.
Leakage current when switched off		0.1 mA max.
Maximum power of filament lamp		9.6 W
Inductive load		L/R = 10 ms
De-rating	- 10...55 °C (14...131 °F)	No de-rating
Turn on time		450 µs
Turn off time		450 µs
Protection against short circuit		Yes
Short circuit output peak current		1 A typically
Automatic rearming after short circuit or overload		Yes, time depending on component temperature
Protection against reverse polarity		Yes
Clamping voltage		Typically 50 Vdc
Switching frequency	Under resistive load	100 Hz max.
Isolation	Between output and internal logic	500 Vac
	Between channel group	N/A
Connection type		HE10 (MIL 20) connector
Connector insertion/removal durability		Over 100 times
Current draw on 5 Vdc internal bus		20 mA (all outputs on), 5mA (all outputs off)
Current draw on 24 Vdc internal bus		16 mA (all outputs on), 0 mA (all outputs off)

Dimension & Wiring Diagram (TM3DQ16TK)

	<p>LED</p>	<table border="1"> <tr> <td>Color</td> <td>Green</td> </tr> <tr> <td colspan="2">Status LED</td> </tr> <tr> <td colspan="2">On: Activated</td> </tr> <tr> <td colspan="2">Off: Disactivated</td> </tr> </table>	Color	Green	Status LED		On: Activated		Off: Disactivated	
Color	Green									
Status LED										
On: Activated										
Off: Disactivated										
	<p>* Type T Fuse</p>									
<p>The 24 Vdc power supplies must be rated at least Protective Extra Low Voltage (PELV) according to IEC 61140. These power supplies are isolated between the electrical input and output circuits of the power supply.</p> <p>For more information on the cable color for TWDFCW30K/TWDFCW50K, refer to TWDFCW••K Cable Description.</p>										

12.4.9 TM3DQ32UK

The table below describes the outputs characteristics of the TM3DQ32UK:

Characteristic		Value
Number of output channels		32
Number of channel groups		2 groups of 16 channels, 1 common line each on 2 pins
Output type		Transistor
Logic type		Sink
Rated output voltage		24 Vdc
Output voltage range		19.2. 28.8 Vdc
Rated output current		0.1 A
Total output current per group		2 A
Voltage drop		0.4 Vdc max.
Leakage current when switched off		0.1 mA max.
Maximum power of filament lamp		2.4 W
Inductive load		L/R = 10 ms
De-rating	- 10...55 °C (14...131 °F)	No de-rating
Turn on time		450 µs
Turn off time		450 µs
Protection against short circuit		No, fast external fuse required
Short circuit output peak current		N/A
Automatic rearming after short circuit or overload		N/A
Protection against reverse polarity		yes
Clamping voltage		Typically 50 Vdc
Switching frequency	Under resistive load	100 Hz max.
Isolation	Between output and internal logic	500 Vac
Connection type		HE10 (MIL 20) connectors
Connector insertion/removal durability		Over 100 times
Current draw on 5 Vdc internal bus		27 mA (all outputs on), 5 mA (all outputs off)
Current draw on 24 Vdc internal bus		31 mA (all outputs on), 0 mA (all outputs off)

Dimension & Wiring Diagram (TM3DQ32UK)

<p>Dimensions</p> <p style="text-align: center;">Connector</p>	<p>LED</p> <table border="1" style="width: 100%; text-align: center; border-collapse: collapse;"> <thead> <tr> <th style="width: 50%;">OUT</th> <th style="width: 50%;">OUT</th> </tr> </thead> <tbody> <tr><td>0</td><td>16</td></tr> <tr><td>1</td><td>17</td></tr> <tr><td>2</td><td>18</td></tr> <tr><td>3</td><td>19</td></tr> <tr><td>4</td><td>20</td></tr> <tr><td>5</td><td>21</td></tr> <tr><td>6</td><td>22</td></tr> <tr><td>7</td><td>23</td></tr> <tr><td>8</td><td>24</td></tr> <tr><td>9</td><td>25</td></tr> <tr><td>10</td><td>26</td></tr> <tr><td>11</td><td>27</td></tr> <tr><td>12</td><td>28</td></tr> <tr><td>13</td><td>29</td></tr> <tr><td>14</td><td>30</td></tr> <tr><td>15</td><td>31</td></tr> </tbody> </table> <table border="1" style="width: 100%; text-align: center; border-collapse: collapse;"> <thead> <tr> <th style="width: 50%;">Color</th> <th style="width: 50%;">Green</th> </tr> </thead> <tbody> <tr> <td colspan="2">Status LED</td> </tr> <tr> <td colspan="2">On: Activated</td> </tr> <tr> <td colspan="2">Off: Disactivated</td> </tr> </tbody> </table>	OUT	OUT	0	16	1	17	2	18	3	19	4	20	5	21	6	22	7	23	8	24	9	25	10	26	11	27	12	28	13	29	14	30	15	31	Color	Green	Status LED		On: Activated		Off: Disactivated	
OUT	OUT																																										
0	16																																										
1	17																																										
2	18																																										
3	19																																										
4	20																																										
5	21																																										
6	22																																										
7	23																																										
8	24																																										
9	25																																										
10	26																																										
11	27																																										
12	28																																										
13	29																																										
14	30																																										
15	31																																										
Color	Green																																										
Status LED																																											
On: Activated																																											
Off: Disactivated																																											
	<p>* Type T fuse ** Type F fuse</p> <p>(1) The V0+ terminals are connected internally. The V0- terminals are connected internally. The V1+ terminals are connected internally. The V1- terminals are connected internally. The V0+ and V1+ terminals are not connected internally. The V0- and V1- terminals are not connected internally.</p>																																										
<p>The 24 Vdc power supplies must be rated at least Protective Extra Low Voltage (PELV) according to IEC 61140. These power supplies are isolated between the electrical input and output circuits of the power supply.</p> <p>For more information on the cable color for TWDFCW30K/TWDFCW50K, refer to TWDFCW**K Cable Description.</p>																																											

12.4.10 TM3DQ32TK

The table below describes the outputs characteristics of the TM3DQ32TK:

Characteristic		Value
Number of output channels		32
Number of channel groups		2 groups of 16 channels, 1 common line each on 2 pins
Output type		Transistor
Logic type		Source
Rated output voltage		24 Vdc
Output voltage range		19.2. 28.8 Vdc
Rated output current		0.1 A
Total output current per group		2 A
Voltage drop		0.4 Vdc max.
Leakage current when switched off		0.1 mA max.
Maximum power of filament lamp		2.4 W
Inductive load		L/R = 10 ms
De-rating	- 10...55 °C (14...131 °F)	No de-rating
Turn on time		450 µs
Turn off time		450 µs
Protection against short circuit		yes
Short circuit output peak current		1 A typically
Automatic rearming after short circuit or overload		Yes, time depending on component temperature
Protection against reverse polarity		yes
Clamping voltage		Typically 50 Vdc
Switching frequency	Under resistive load	100 Hz max.
Isolation	Between output and internal logic	500 Vac
Connection type		HE10 (MIL 20) connectors
Connector insertion/removal durability		Over 100 times
Current draw on 5 Vdc internal bus		27 mA (all outputs on), 5 mA (all outputs off)
Current draw on 24 Vdc internal bus		31 mA (all outputs on), 0 mA (all outputs off)

Dimension & Wiring Diagram (TM3DQ32TK)

<p>mm in.</p> <p>LED</p> <p>Connector</p>	<p>LED</p>	<table border="1"> <thead> <tr> <th>Color</th> <th>Green</th> </tr> </thead> <tbody> <tr> <td colspan="2">Status LED</td> </tr> <tr> <td colspan="2">On: Activated</td> </tr> <tr> <td colspan="2">Off: Disactivated</td> </tr> </tbody> </table>	Color	Green	Status LED		On: Activated		Off: Disactivated	
Color	Green									
Status LED										
On: Activated										
Off: Disactivated										
	<p>* Type T Fuse</p> <p>(1)</p> <p>The V0+ terminals are connected internally.</p> <p>The V0- terminals are connected internally.</p> <p>The V1+ terminals are connected internally.</p> <p>The V1- terminals are connected internally.</p> <p>The V0+ and V1+ terminals are not connected internally.</p> <p>The V0- and V1- terminals are not connected internally.</p>									
<p>The 24 Vdc power supplies must be rated at least Protective Extra Low Voltage (PELV) according to IEC 61140. These power supplies are isolated between the electrical input and output circuits of the power supply.</p> <p>For more information on the cable color for TWDFCW30K/TWDFCW50K, refer to TWDFCW**K Cable Description.</p>										

12.5 Digital Input/Output Modules

12.5.1 TM3DM8R / TM3DM8RG

The table below describes the inputs characteristics of the TM3DM8R / TM3DM8RG:

Characteristic		Value
Number of input channels		4 inputs
Number of channels groups		1 common line for 4 channels
Input type		Type 1 (IEC/EN 61131-2)
Logic type		Sink/source
Rated input voltage		24 Vdc
Input voltage range		19.2.. 28.8 Vdc
Rated input current		7 mA
Input impedance		3.4 kΩ
Input limit values	Voltage at state 1	> 15 Vdc (15..28.8Vdc)
	Voltage at state 0	< 5 Vdc (0..5 Vdc)
	Current at state 1	> 2.5 mA
	Current at state 0	< 1.0 mA
Turn on time		SV ^{*1} < 2.0: 4ms
Turn off time		SV ^{*1} ≥2.0: 100μs ^{*2}
Isolation	Between input and internal logic	500 Vac
	Between input group and output group	1500 Vac
	Between input groups	N/A
Connection type	TM3DM8R	Removable screw terminal block
	TM3DM8RG	Removable spring terminal block
Connector insertion/removal durability		Over 100 times
Current draw on 5 Vdc internal bus		24 mA (all inputs and outputs on)
		5 mA (all inputs and outputs off)
Current draw on 24 Vdc internal bus		20 mA (all inputs and outputs on)
		0 mA (all inputs and outputs off)
*1 SV refers to the version and is printed on the product label.		
*2 The range depends on the configured filter value.		

The table below describes the outputs characteristics of the TM3DM8R / TM3DM8RG:

Characteristic		Value
Number of output channels		4 outputs
Number of channel groups		1 common line for 4 channels
Output type		Relay
Contact type		NO (Normally Open)
Rated output voltage		24 Vdc, 240 Vac
Maximum voltage		30 Vdc, 264 Vac
Minimum switching load		5 Vdc at 10 mA
Rated output current		2 A
Maximum output current		2 A per output
		7 A per common
Maximum output frequency		20 operations per minute
Turn on time		Max. 10 ms
Turn off time		Max. 10 ms
Contact resistance		30 mΩ max
Mechanical life		20 million operations
Electrical life	Under resistive load	See Power Limitation in the next page
	Under inductive load	
Protection against short circuit		No
Isolation	Between input and internal logic	500 Vac
	Between input group and output group	1500 Vac
	Between input groups	N/A
Connection type	TM3DM8R	Removable screw terminal block
	TM3DM8RG	Removable spring terminal block
Connector insertion/removal durability		Over 100 times
Current draw on 5 Vdc internal bus		24 mA (all inputs and outputs on)
		5 mA (all inputs and outputs off)
Current draw on 24 Vdc internal bus		20 mA (all inputs and outputs on)
		0 mA (all inputs and outputs off)

- Power Limitation

This table describes the power limitations of the TM3DQ8R / TM3DQ8RG expansion module depending on the voltage, the type of load, and the number of operations required.

These expansion modules do not support capacitive loads.

Voltage	24 Vdc	120 Vac	240 Vac	Number of operations
Power of resistive loads AC-12	-	240 VA	480 VA	100,000
		80 VA	160 VA	300,000
Power of inductive loads AC-15 ($\cos \phi = 0.35$)	-	60 VA	120 VA	100,000
		18 VA	36 VA	300,000
Power of inductive loads AC-14 ($\cos \phi = 0.7$)	-	120 VA	240 VA	100,000
		36 VA	72 VA	300,000
Power of resistive loads DC-12	48W	-	-	100,000
	16W	-	-	300,000
Power of inductive loads DC-13 L/R = 7 ms	24W	-	-	100,000
	7.2W	-	-	300,000

Dimension & Wiring Diagram (TM3DM8R / TM3DM8RG)

	<p style="text-align: center;">LED</p> <table border="1" style="width: 100%; border-collapse: collapse; margin-top: 10px;"> <thead> <tr> <th>Type</th> <th>Operation</th> </tr> </thead> <tbody> <tr> <td>Input</td> <td>On: Activated Off: Disactivated</td> </tr> <tr> <td>Output</td> <td>On: Activated Off: Disactivated</td> </tr> </tbody> </table>	Type	Operation	Input	On: Activated Off: Disactivated	Output	On: Activated Off: Disactivated
Type	Operation						
Input	On: Activated Off: Disactivated						
Output	On: Activated Off: Disactivated						
<p>* Type T Fuse</p> <p>(1) The COM0 and COM1 terminals are not connected internally.</p> <p>(2) To improve the life time of the contacts, and to protect from potential inductive load damage, connect a freewheeling diode in parallel to each inductive DC load or an RC snubber in parallel of each inductive AC load, or a varistor on either type of load.</p> <p>C Source wiring (positive logic)</p> <p>D Sink wiring (negative logic)</p> <p>NOTE: When you use the TM3 expansion module with a TM3 Ethernet bus coupler, you must connect an RC snubber in parallel of each inductive AC load.</p> <p>-----</p> <p>The 24 Vdc power supplies must be rated at least Protective Extra Low Voltage (PELV) according to IEC 61140. These power supplies are isolated between the electrical input and output circuits of the power supply.</p>							

12.5.2 TM3DM24R / TM3DM24RG

The table below describes the inputs characteristics of the TM3DM24R / TM3DM24RG:

Characteristic		Value
Number of input channels		16 inputs
Number of channels groups		1 common line for 16 channels
Input type		Type 1 (IEC/EN 61131-2)
Logic type		Sink/source
Rated input voltage		24 Vdc
Input voltage range		19.2..28.8 Vdc
Rated input current		7 mA
Input impedance		3.4 kΩ
Input limit values	Voltage at state 1	> 15 Vdc (15 28.8 Vdc)
	Voltage at state 0	< 5 Vdc (0..5 Vdc)
	Current at state 1	> 2.5 mA
	Current at state 0	< 1.0 mA
Turn on time		SV ^{*1} < 2.0: 4ms
Turn off time		SV ^{*1} ≥ 2.0: 100μs ^{*2}
Isolation	Between input and internal logic	500 Vac
	Between input group and output group	1500 Vac
	Between input groups	N/A
Connection type	TM3DM24R	Removable screw terminal block
	TM3DM24RG	Removable spring terminal block
Connector insertion/removal durability		Over 100 times
Current draw on 5 Vdc internal bus		42 mA (all inputs and outputs on)
		5 mA (all inputs and outputs off)
Current draw on 24 Vdc internal bus		39 mA (all inputs and outputs on)
		0 mA (all inputs and outputs off)
<p>*1 SV refers to the version and is printed on the product label.</p> <p>*2 The range depends on the configured filter value.</p>		

The table below describes the outputs characteristics of the TM3DM24R / TM3DM24RG:

Characteristic		Value
Number of output channels		8
Number of channel groups		2 common line for 8 channels
Output type		Relay
Contact type		NO (Normally Open)
Rated output voltage		24 Vdc, 240 Vac
Maximum voltage		30 Vdc, 264 Vac
Minimum switching load		5 Vdc at 10 mA
Rated output current		2 A
Maximum output current		2 A per channels
		7 A per commons
Maximum output frequency	with maximum load	20 operations per minute
Turn on time		Max. 10 ms
Turn off time		Max. 10 ms
Contact resistance		30 mW
Mechanical life		20 million operations
Under resistive load		See Power limitation in the next page
Under inductive load		
Protection against short circuit		No
Between input and internal logic		500 Vac
Between input group and output group		1500 Vac
Between input groups		N/A
TM3DM24R		Removable screw terminal block
TM3DM24RG		Removable spring terminal block
Connector insertion/removal durability		Over 100 times
Current draw on 5 Vdc internal bus		42 mA (all inputs and outputs on)
		5 mA (all inputs and outputs off)
Current draw on 24 Vdc internal bus		39 mA (all inputs and outputs on)
		0 mA (all inputs and outputs off)

- Power Limitation

This table describes the power limitations of the TM3DM24R / TM3DM24RG expansion module depending on the voltage, the type of load, and the number of operations required.

These expansion modules do not support capacitive loads.

Voltage	24 Vdc	120 Vac	240 Vac	Number of operations
Power of resistive loads AC-12	-	240 VA 80 VA	480 VA 160 VA	100,000 300,000
Power of inductive loads AC-15 (cos ϕ = 0.35)	-	60 VA 18 VA	120 VA 36 VA	100,000 300,000
Power of inductive loads AC-14 (cos ϕ = 0.7)	-	120 VA 36 VA	240 VA 72 VA	100,000 300,000
Power of resistive loads DC-12	48W 16W	-	-	100,000 300,000
Power of inductive loads DC-13 L/R = 7 ms	24W 7.2W	-	-	100,000 300,000

Dimension & Wiring Diagram (TM3DM24R / TM3DM24RG)

mm
in.

70
2.76

3,8
0.15

39,1
1.53

90
3.54

5*
0.20

LED

Connector

LED

IN	OUT
0	0
1	1
2	2
3	3
4	4
5	5
6	6
7	7
8	
9	
10	
11	
12	
13	
14	
15	

Type	Operation
Input	On: Activated
	Off: Disactivated
Output	On: Activated
	Off: Disactivated

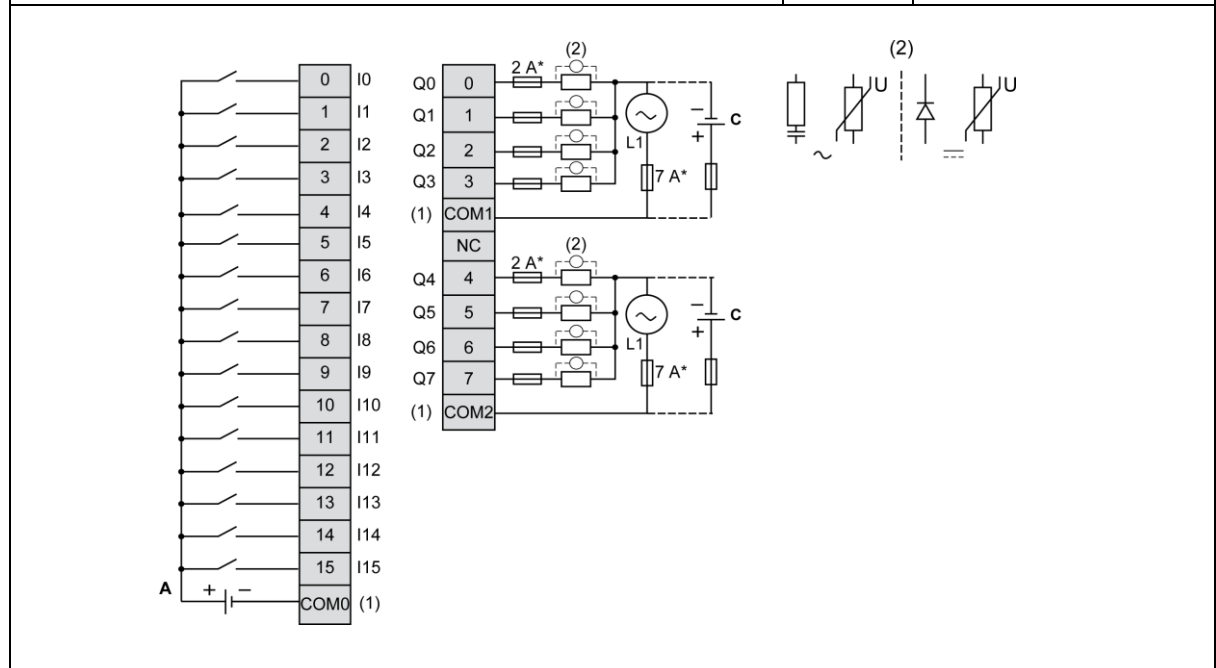

* Type T Fuse

(1) The COM0 and COM1 terminals are not connected internally.

(2) To improve the life time of the contacts, and to protect from potential inductive load damage, connect a freewheeling diode in parallel to each inductive DC load or an RC snubber in parallel of each inductive AC load, or a varistor on either type of load.

C Source wiring (positive logic)

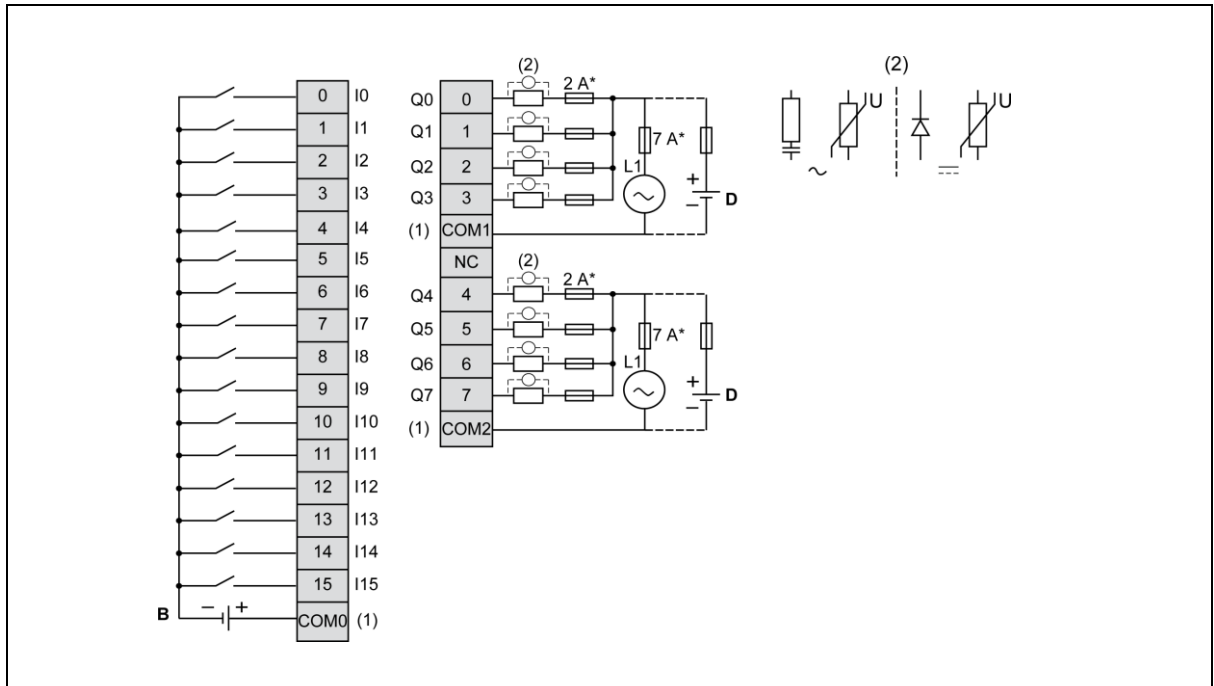

* Type T Fuse

(1) The COM0 and COM1 terminals are not connected internally.

(2) To improve the life time of the contacts, and to protect from potential inductive load damage, connect a freewheeling diode in parallel to each inductive DC load or an RC snubber in parallel of each inductive AC load, or a varistor on either type of load.

D Sink wiring (negative logic)

NOTE: When you use the TM3 expansion module with a TM3 Ethernet bus coupler, you must connect an RC snubber in parallel of each inductive AC load.

The 24 Vdc power supplies must be rated at least Protective Extra Low Voltage (PELV) according to IEC 61140. These power supplies are isolated between the electrical input and output circuits of the power supply.

12.6 Analog Input Modules

12.6.1 TM3AI2H / TM3AI2HG

General Characteristics

Characteristics	Value
Rated power supply voltage	24 Vdc
Power supply range	20.4...28.8 Vdc
Connector insertion/removal durability	100 times minimum
Current draw on 5 Vdc internal bus	30 mA (no load), 30 mA (full load)
Current draw on 24 Vdc internal bus	0 mA
Current draw on external 24 Vdc	25 mA (no load), 25 mA (full load)

Input Characteristics

Characteristics	Value	
	Voltage Input	Current Input
Input range	0...10 Vdc -10...+10 Vdc	0...20 mA 4...20 mA
Input impedance	1 M Ω min	50 Ω max
Sample duration time	1 ms per enabled channel	
Input type	Single-ended input	
Operating mode	Self-scan	
Conversion mode	Sigma delta ADC	
Max accuracy at ambient 25 °C (77 °F)	\pm 0.1 % of full scale	
Temperature drift	\pm 0.006 % of full scale	
Repeatability after stabilization time	\pm 0.5 % of full scale	
Nonlinearity	\pm 0.01 % of full scale	
Maximum input deviation	\pm 1.0 % of full scale	
Resolution	16 bits, or 15 bits + sign (65536 points)	
Input value of LSB	0.153 mV (range 0...10 Vdc) 0.305 mV (range -10...+10 Vdc)	0.305 μ A (range 0...20 mA) 0.244 μ A (range 4...20 mA)
Data type in application program	Scalable from -32768 to 32767	
Input data out of range detection	Yes	

Characteristics		Value	
		Voltage Input	Current Input
Noise Resistance	Maximum temporary deviation during perturbations	±4 % maximum when EMC perturbation is applied to the power and I/O wiring	
	Cable	Twisted-pair shielded cable, max 30 m	
	Crosstalk	1 LSB max	
Isolation	Between external power supply and inputs	1500 Vac	
	Between inputs and internal logic circuits	500 Vac	
Maximum continuous allowed overload (no damage)		13 Vdc	40 mA
Input filter		Software filter: 0...10 s (per 0.01 s unit)	
Behavior when external power is off		Input value is 0 The External power supply error status bit in the controller is ON.	

Dimension & Wiring Diagram (TM3AI2H / TM3AI2HG)

	<p>LED</p>	<table border="1"> <tr> <td>Color</td> <td>Green</td> </tr> <tr> <td colspan="2">Status LED</td> </tr> <tr> <td colspan="2">On: Activated</td> </tr> <tr> <td colspan="2">Off: Disactivated</td> </tr> </table>	Color	Green	Status LED		On: Activated		Off: Disactivated	
Color	Green									
Status LED										
On: Activated										
Off: Disactivated										
	<p>* Type T fuse (1) Current/Voltage analog output device</p>									
<p>Do not connect wires to unused terminals and/or terminals indicated as "No Connection (N.C.)".</p>										

12.6.2 TM3AI4 / TM3AI4G

General Characteristics

Characteristic	Value
Rated power supply voltage	24 Vdc
Power supply range	20.4...28.8 Vdc
Connector insertion/removal durability	100 times minimum
Current draw on 5 Vdc internal bus	40 mA (no load), 40 mA (full load)
Current draw on 24 Vdc internal bus	0 mA
Current draw on external 24 Vdc	30 mA (no load), 30 mA (full load)

Input Characteristics

Characteristics	Value	
	Voltage input	Current input
Input range	0...10 Vdc -10...+10 Vdc	0...20 mA 4...20 mA
Input impedance	1 M Ω min	50 Ω max
Sample duration time	1 ms per enabled channel	
Input type	Single-ended input	
Operating mode	Self-scan	
Conversion mode	Sigma delta ADC	
Max accuracy at ambient 25 °C (77 °F)	± 0.2 % of full scale	
Temperature drift	± 0.01 % of full scale	
Repeatability after stabilization time	± 0.5 % of full scale	
Nonlinearity	± 0.2 % of full scale	
Maximum input deviation	± 1.0 % of full scale	
Resolution	12 bits, or 11 bits + sign (4096 points)	
Input value of LSB	2.44 mV (range 0...10 Vdc) 4.88 mV (range -10...+10 Vdc)	4.88 μ A (range 0...20 mA) 3.91 μ A (range 4...20 mA)
Data type in application program	Scalable from -32768 to 32767	
Input data out of range detection	Yes	

Characteristics		Value	
		Voltage input	Current input
Noise	Maximum temporary deviation during perturbations	±4 % maximum when EMC perturbation is applied to the power and I/O wiring	
Resistance	Cable	Twisted-pair shielded cable, max 30 m	
	Crosstalk	1 LSB max	
Isolation	Between external power supply and inputs	1500 Vac	
	Between inputs and internal logic circuits	500 Vac	
Maximum continuous allowed overload (no damage)		13 Vdc	40 mA
Input filter		Software filter: 0...10 s (per 0.01 s unit)	
Behavior when external power is off		Input value is 0 The External power supply error status bit in the controller is ON.	

Dimension & Wiring Diagram (TM3AI4 / TM3AI4G)

	<p>LED</p>	<table border="1"> <tr> <td>Color</td> <td>Green</td> </tr> <tr> <td colspan="2">Status LED</td> </tr> <tr> <td colspan="2">On: Activated</td> </tr> <tr> <td colspan="2">Off: Disactivated</td> </tr> </table>	Color	Green	Status LED		On: Activated		Off: Disactivated	
Color	Green									
Status LED										
On: Activated										
Off: Disactivated										
	<p>* Type T fuse (1) Current/Voltage analog output device</p>									

12.6.3 TM3TI4 / TM3TI4G

General Characteristics

Characteristics	Value
Rated power supply voltage	24 Vdc
Power supply range	20.4. 28.8 Vdc
Connector insertion/removal durability	100 times minimum
Current draw on 5 Vdc internal bus	40 mA (no load), 40 mA (full load)
Current draw on 24 Vdc internal bus	0 mA
Current draw on external 24 Vdc	35 mA (no load), 40 mA (full load)

Input Characteristics

Characteristics	Value					
	Voltage input	Current input	Thermocouple type		3-wire-RTD	
Input range	0...10 Vdc -10...+10 Vdc	0...20 mA 4...20 mA	K	-200...1300 °C	PT100	-200...850 °C
				(-328...2372 °F)		(-328...1562 °F)
	J	-200...1000 °C	PT1000	-200...600 °C		
		(-328...1832 °F)		(-328...1112 °F)		
	R	0...1760 °C	NI100	-60...180 °C		
		(32...3200 °F)		(-76...356 °F)		
	S	0...1760 °C	NI 1000	-60...180 °C		
		(32...3200 °F)		(-76...356 °F)		
	B	0...1820 °C	-			
(32...3308 °F)						
E	-200...800 °C					
(-328...1472 °F)						
T	-200...400 °C					
(-328...752 °F)						
N	-200...1300 °C					
(-328...2372 °F)						
C	0...2315 °C					
(32...4199 °F)						
Input impedance	1 MΩ min	50 Ω max	1 MΩ min			
Sample duration time (software configurable)	10 ms or 100 ms per enabled channel		100 ms per enabled channel			

Characteristics	Value			
	Voltage input	Current input	Thermocouple type	3-wire-RTD
Input type	Single-ended input. Use only isolated thermocouples. All the shields of the sensor cables must be referenced to the logic controller ground.			
Operating mode	Self-scan			
Conversion mode	Sigma delta ADC			
Max accuracy at ambient 25 °C (77 °F)	±0.2 % of full scale			
			Cold junction accuracy ±4.0 °C (±7.2 °F)	
			except:	
			R ±6.0 °C S (0...200 °C) (±10.8 °F (32...392 °F))	
			B Not available (0...300 °C (32...572 °F))	
			K ±0.4 % of full scale under 0 °C (32 °F)	
			E T N	
Temperature drift	±0.01 % of full scale			
Repeatability after stabilization time	±0.5 % of full scale			
Nonlinearity	±0.2 % of full scale			
Maximum input deviation	±1.0 % of full scale			
Resolution	16 bits, or 15 bits + sign (65536 points)		K 15000 points J 12000 points R 17600 points S 17600 points B 18200 points E 10000 points T 6000 points N 15000 points C 23150 points	PT100 10500 points PT1000 8000 points NI100 2400 points NI1000 2400 points
Input value of LSB	2.44 mV (range 0...10 Vdc) 4.88 mV (range -10...+10 Vdc)	4.88 µA (range 0...20 mA) 3.91 µA (range 4...20 mA)	0.1 °C (0.18 °F)	

Characteristics		Value			
		Voltage input	Current input	Thermocouple type	3-wire-RTD
Data type in application program		Scalable from –32768 to 32767			
Input data out of range detection		Yes			
Noise resistance	Maximum temporary deviation during perturbations	±4 % maximum when EMC perturbation is applied to the power and I/O wiring			
	Cable	Twisted-pair shielded cable			
	Crosstalk	1 LSB max			
Isolation	Between external power supply and inputs	1500 Vac			
	Between inputs and internal logic circuits	500 Vac			
	Between inputs	Not isolated			
Maximum continuous allowed overload (no damage)		13 Vdc	40 mA	N/A	
Input filter		Software filter: 0...10 s (per 0.01 s unit)			
Behavior when temperature sensor is broken		N/A		Input value is highest limit value Highest limit flag is ON	
Behavior when external power is off		Input value is 0		Input value is highest limit value	
		The External power supply error status bit in the controller is ON.			

Dimension & Wiring Diagram (TM3T14 / TM3T14G)

<div style="display: flex; justify-content: space-between;"> <div style="text-align: left;"> <p>$\frac{\text{mm}}{\text{in.}}$</p> </div> <div style="text-align: center;"> <p>LED</p> </div> </div>	<table border="1" style="width: 100%; border-collapse: collapse;"> <tr> <td style="width: 20%; text-align: center;">LED</td> <td style="width: 20%; text-align: center;">Color</td> <td style="width: 60%; text-align: center;">Green</td> </tr> <tr> <td colspan="3" style="text-align: center;">Status LED</td> </tr> <tr> <td colspan="3" style="text-align: center;">On: Activated</td> </tr> <tr> <td colspan="3" style="text-align: center;">Off: Disactivated</td> </tr> </table>	LED	Color	Green	Status LED			On: Activated			Off: Disactivated		
LED	Color	Green											
Status LED													
On: Activated													
Off: Disactivated													

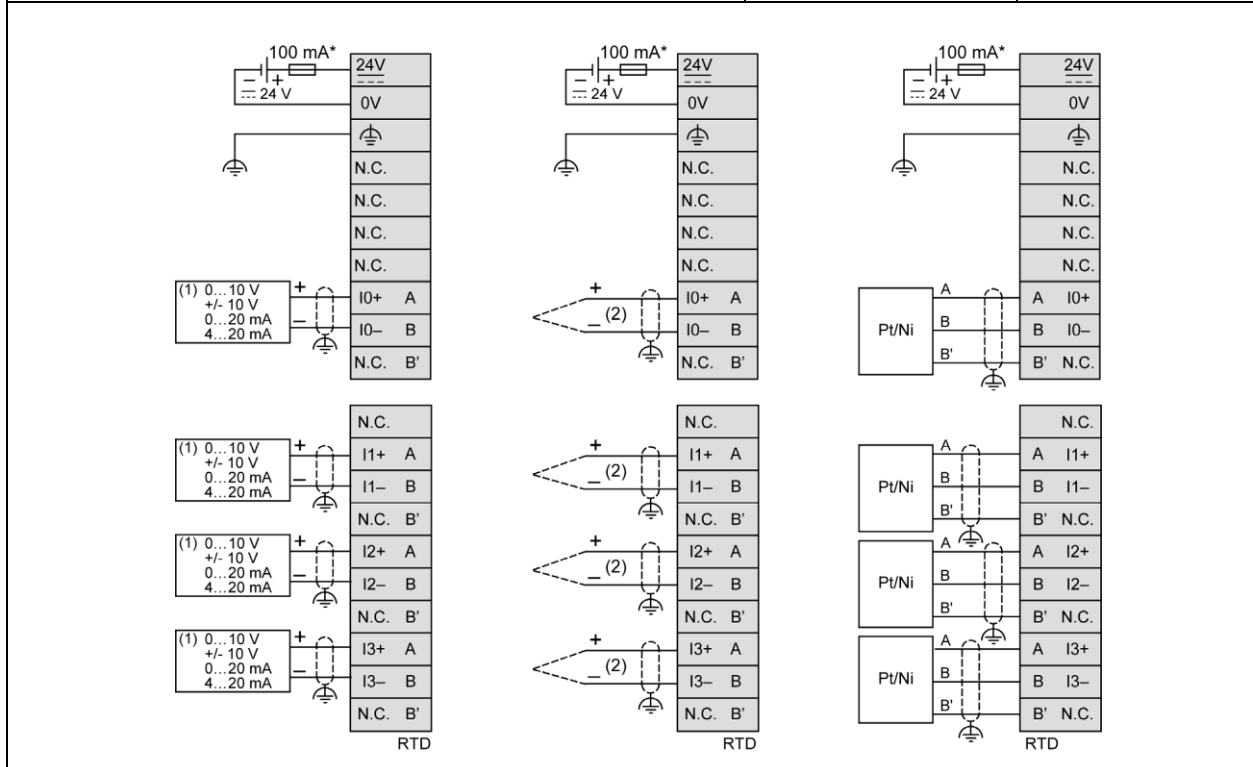

- * Type T fuse
 - (1) Current/Voltage analog output device
 - (2) Electrically isolated thermocouple only
- RTD (A, B, B'): Resistance Temperature Detector

12.6.4 TM3TI4D / TM3TI4DG

General Characteristics

Characteristic	Value
Rated power supply voltage	24 Vdc
Power supply range	20.4. 28.8 Vdc
Connector insertion/removal durability	100 times minimum
Current draw on 5 Vdc internal bus	40 mA (no load), 40 mA (full load)
Current draw on 24 Vdc internal bus	0 mA
Current draw on external 24 Vdc	35 mA (no load), 40 mA (full load)

Input Characteristics

Characteristics	Value	
	Thermocouple type	
Input range	K	–200...1300 °C (–328...2372 °F)
	J	–200...1000 °C (–328...1832 °F)
	R	0...1760 °C (32...3200 °F)
	S	0...1760 °C (32...3200 °F)
	B	0...1820 °C (32...3308 °F)
	E	–200...800 °C (–328...1472 °F)
	T	–200...400 °C (–328...752 °F)
	N	–200...1300 °C (–328...2372 °F)
	C	0...2315 °C (32...4199 °F)
Input impedance	1 MΩ min	
Sample duration time (software configurable)	100 ms per enabled channel	
Input type	Single-ended input. Use isolated or non isolated thermocouples. All the shields of the sensor cables must be referenced to the logic controller ground.	
Operating mode	Self-scan	
Conversion mode	Sigma delta ADC	

Characteristics	Value	
	Thermocouple type	
Max accuracy at ambient 25 °C (77 °F)	±0.2 % of full scale	
	Cold junction accuracy ±4.0 °C (±7.2 °F)	
	except:	
	R	±6.0 °C (0...200 °C) (±10.8 °F (32...392 °F))
	S	
	B	Not available (0...300 °C (32...572 °F))
K	±0.4 % of full scale under 0 °C (32 °F)	
J		
E		
T		
N		
Temperature drift	±0.01 % of full scale	
Repeatability after stabilization time	±0.5 % of full scale	
Nonlinearity	±0.2 % of full scale	
Maximum input deviation	±1.0 % of full scale	
Resolution	K	15000 points
	J	12000 points
	R	17600 points
	S	17600 points
	B	18200 points
	E	10000 points
	T	6000 points
	N	15000 points
	C	23150 points
Input value of LSB	0.1 °C (0.18 °F)	
Data type in application program	Scalable from -32768 to 32767	
Input data out of range detection	Yes	

Characteristics		Value
		Thermocouple type
Noise resistance	Maximum temporary deviation during perturbations	±4 % maximum when EMC perturbation is applied to the power and I/O wiring
	Cable	Twisted-pair shielded cable
Isolation	Crosstalk	1 LSB max
	Between external power supply and inputs	1500 Vac
	Between inputs and internal logic circuits	500 Vac
	Between inputs	250 Vac
Maximum continuous allowed overload (no damage)		N/A
Input filter		Software filter: 0...10 s (per 0.01 s unit)
Behavior when temperature sensor is broken		Input value is highest limit value. Highest limit flag is ON
Behavior when external power is off		Input value is highest limit value
		The external power supply error status bit in the controller is ON.

Dimension & Wiring Diagram (TM3TI4D / TM3TI4DG)

	<p>LED</p>	<table border="1"> <tr> <td>Color</td> <td>Green</td> </tr> <tr> <td colspan="2">Status LED</td> </tr> <tr> <td colspan="2">On: Activated</td> </tr> <tr> <td colspan="2">Off: Disactivated</td> </tr> </table>	Color	Green	Status LED		On: Activated		Off: Disactivated	
Color	Green									
Status LED										
On: Activated										
Off: Disactivated										
	<p>* Type T fuse (1) Electrically isolated or non isolated thermocouple</p>									
<p>Do not connect wires to unused terminals and/or terminals indicated as "No Connection (N.C.)".</p>										

12.6.5 TM3AI8 / TM3AI8G

General Characteristics

Characteristics	Value
Rated power supply voltage	24 Vdc
Power supply range	20.4. 28.8 Vdc
Connector insertion/removal durability	100 times minimum
Current draw on 5 Vdc internal bus	35 mA (no load) 35 mA (full load)
Current draw on 24 Vdc internal bus	0 mA
Current draw on external 24 Vdc	30 mA (no load) 40 mA (full load)

Input Characteristics

Characteristics	Value	
	Voltage input	Current input
Input range	0...10 Vdc -10...+10 Vdc	0...20 mA 4...20 mA 0...20 mA extended 4...20 mA extended
Input impedance	1 M Ω min	50 Ω max
Sample duration time	1 ms per enabled channel	
Input type	Single-ended input	
Operating mode	Self-scan	
Conversion mode	Sigma delta ADC	
Max accuracy at ambient 25 °C (77 °F)	\pm 0.2 % of full scale	
Temperature drift	\pm 0.01 % of full scale	
Repeatability after stabilization time	\pm 0.5 % of full scale	
Nonlinearity	\pm 0.2 % of full scale	
Maximum input deviation	\pm 1.0 % of full scale	
Resolution	12 bits, or 11 bits + sign (4096 points)	
Input value of LSB	2.44 mV (range 0...10 Vdc) 4.88 mV (range -10...+10 Vdc)	4.88 μ A (range 0...20 mA) 3.91 μ A (range 4...20 mA)
Data type in application program	Scalable from -32768 to 32767	
Input data out of range detection	Yes	

Characteristics		Value	
		Voltage input	Current input
Noise resistance	Maximum temporary deviation during perturbations	±4 % maximum when EMC perturbation is applied to the power and I/O wiring	
	Cable	Twisted-pair shielded cable, max 30 m	
	Crosstalk	1 LSB max	
Isolation	Between external power supply and inputs	1500 Vac	
	Between inputs and internal logic circuits	500 Vac	
Maximum continuous allowed overload (no damage)		13 Vdc	40 mA
Input filter		Software filter: 0...10 s (per 0.01 s unit)	
Behavior when external power is off		Input value is 0 The External power supply error status bit in the controller is ON.	

Dimension & Wiring Diagram (TM3A18 / TM3A18G)

	<p>LED</p>	<table border="1"> <tr> <th>Color</th> <td>Green</td> </tr> <tr> <th>Status LED</th> <td>On: Activated Off: Disactivated</td> </tr> </table>	Color	Green	Status LED	On: Activated Off: Disactivated
Color	Green					
Status LED	On: Activated Off: Disactivated					
	<p>* Type T fuse (1) Current/Voltage analog output device</p>					
<p>Do not connect wires to unused terminals and/or terminals indicated as "No Connection (N.C.)".</p>						

12.7 Analog Output Module

12.7.1 TM3AQ2 / TM3AQ2G

General Characteristics

Characteristic	Value
Rated power supply voltage	24 Vdc
Power supply range	20.4...28.8 Vdc
Connector insertion/removal durability	100 times minimum
Current draw on 5 Vdc internal bus	30 mA (all outputs on), 40 mA (all outputs off)
Current draw on 24 Vdc internal bus	0 mA
Current draw on external 24 Vdc	30 mA (all outputs on), 70 mA (all outputs off)

Output Characteristics

Characteristic	Value	
	Voltage Output	Current Output
Output range	0...10Vdc -10...+10Vdc	0...20mA 4...20mA
Load impedance	1k Ω min	300 Ω max
Application load type	Resistive load	
Setting time	1ms	
Max accuracy at ambient 25 °C (77 °F)	± 0.1 % of full scale	
Temperature drift	± 0.006 % of full scale	
Repeatability after stabilization time	± 0.4 % of full scale	
Nonlinearity	± 0.01 % of full scale	
Maximum input deviation	± 1.0 % of full scale	
Output ripple	20 mV max	
Overshoot	0%	
Maximum output deviation	± 1.0 % of full scale	
Resolution	12 bits, or 11 bits + sign (4096 points)	
Input value of LSB	2.44mV (range 0...10 Vdc) 2.88mV (range -10...+10 Vdc)	4.88 μ A (range 0...20 mA) 3.91 μ A (range 4...20 mA)
Data type in application program	0...4095 (range 0...10 Vdc) -2048...+2047 (range -10...+10 Vdc)	0...4095
	Scalable from -32768 to 32767	
Input data out of range detection	Yes	
Noise resistance	Maximum temporary deviation during perturbations	± 4 % maximum when EMC perturbation is applied to the power and I/O wiring
	Cable	Twisted pair shielded cable, max 30 m
	Crosstalk	1LSB max

Characteristic		Value	
		Voltage Output	Current Output
Isolation	Between output and internal logic	1500 Vac	
	Between input group and output group	500 Vac	
Output protection		Short- circuit protection	Open- circuit protection
Behavior when external power is off		Input value is 0 The External power supply error status bit in the controller is ON.	

Dimension & Wiring Diagram (TM3AQ2 / TM2AQ2G)

<p>mm in.</p> <p>14,6 0,57</p> <p>70 2,76</p> <p>3,8 0,15</p> <p>23,6 0,93</p> <p>90 3,54</p> <p>5* 0,20</p> <p>LED</p> <p>Connector</p>	<p>LED</p> <p>Color Green</p> <p>Status LED</p> <p>On: Activated</p> <p>Off: Disactivated</p>
<p>160 mA*</p> <p>24V</p> <p>0V</p> <p>Q0+</p> <p>Q0-</p> <p>N.C.</p> <p>N.C.</p> <p>Q1+</p> <p>Q1-</p> <p>N.C.</p> <p>N.C.</p> <p>(1) 0...10 V +/- 10 V 0...20 mA 4...20 mA</p> <p>(1) 0...10 V +/- 10 V 0...20 mA 4...20 mA</p>	<p>* Type T fuse</p> <p>(1) Voltage/current pre-actuator</p>
<p>Do not connect wires to unused terminals and/or terminals indicated as "No Connection (N.C.)".</p>	

12.7.2 TM3AQ4 / TM3AQ4G

General Characteristics

Characteristics	Value
Rated power supply voltage	24 Vdc
Power supply range	20.4. 28.8 Vdc
Connector insertion/removal durability	100 times minimum
Current draw on 5 Vdc internal bus	40 mA (no load) 60 mA (full load)
Current draw on 24 Vdc internal bus	0 mA
Current draw on external 24 Vdc	50 mA (no load) 125 mA (full load)

Output Characteristics

Characteristics	Value	
	Voltage output	Current output
Software configurable signal type	Voltage output	Current output
Output range	0...10 Vdc -10...+10 Vdc	0...20 mA 4...20 mA
Load impedance	1 k Ω min	300 Ω max
Application load type	Resistive load	
Settling time	1 ms	
Max accuracy at ambient 25 °C (77 °F)	\pm 0.2 % of full scale	
Temperature drift	\pm 0.01 % of full scale	
Repeatability after stabilization time	\pm 0.4 % of full scale	
Nonlinearity	\pm 0.2 % of full scale	
Output ripple	20 mV max	
Overshoot	0 %	
Maximum output deviation	\pm 1.0 % of full scale	
Resolution	12 bits, or 11 bits + sign (4096 points)	
Input value of LSB	2.44 mV (range 0...10 Vdc) 4.88 mV (range -10...+10 Vdc)	4.88 μ A (range 0...20 mA) 3.91 μ A (range 4...20 mA)

Characteristics		Value	
		Voltage output	Current output
Data type in application program		0...4095 (range 0...10 Vdc)	0...4095
		-2048...+2047 (range -10...+10 Vdc)	
		Scalable from -32768 to 32767	
Input data out of range detection		Yes	
Noise resistance	Maximum temporary deviation during perturbations	± 4 % maximum when EMC perturbation is applied to the power and I/O wiring	
	Cable	Twisted-pair shielded cable	
	Crosstalk	1 LSB max	
Isolation	Between external power supply and inputs	1500 Vac	
	Between inputs and internal logic circuits	500 Vac	
Output protection		Short-circuit protection	Open-circuit protection
Behavior when external power is off		The External power supply error status bit in the controller is ON.	

Dimension & Wiring Diagram (TM3AQ4 / TM2AQ4G)

<p>mm in.</p> <p>14,6 0,57</p> <p>70 2,76</p> <p>3,8 0,15</p> <p>23,6 0,93</p> <p>90 3,54</p> <p>5* 0,20</p> <p>LED</p> <p>Connector</p> <p>160 mA*</p> <p>24V</p> <p>0V</p> <p>Q0+</p> <p>Q0-</p> <p>Q1+</p> <p>Q1-</p> <p>Q2+</p> <p>Q2-</p> <p>Q3+</p> <p>Q3-</p> <p>(1) 0...10 V +/- 10 V 0...20 mA 4...20 mA</p> <p>(1) 0...10 V +/- 10 V 0...20 mA 4...20 mA</p> <p>(1) 0...10 V +/- 10 V 0...20 mA 4...20 mA</p> <p>(1) 0...10 V +/- 10 V 0...20 mA 4...20 mA</p>	<p>LED</p> <p>Color Green</p> <p>Status LED</p> <p>On: Activated</p> <p>Off: Disactivated</p>
	<p>* Type T fuse</p> <p>(1) Voltage/current pre-actuator</p>

12.8 Analog Input/Output Modules

12.8.1 TM3TM3 / TM3TM3G

General Characteristics

Characteristic	Value
Rated power supply voltage	24 Vdc
Power supply range	20.4...28.8 Vdc
Connector insertion/removal durability	100 times minimum
Current draw on 5 Vdc internal bus	55 mA (all outputs on), 60 mA (all outputs off)
Current draw on 24 Vdc internal bus	0 mA
Current draw on external 24 Vdc	55 mA (all outputs on), 80 mA (all outputs off)

Input Characteristics

Characteristic	Value					
Signal type	Voltage	Current	Thermocouple		3-wire-RTD	
Input range	0...10Vdc -10...+10Vdc	0...20 mA 4...20 mA	K	-200...1300 °C (-328...2372 °F)	PT100	-200...850 °C (-328...1562 °F)
			J	-200...1000 °C (-328...1832 °F)	PT1000	-200...1300 °C (-328...1112 °F)
			R	0...1760 °C (323200 °F)	NI100	-60...1300 °C (-76...356 °F)
			S	0...1760 °C (32...3200 °F)	NI1000	-60...180 °C (-76...356 °F)
			B	0...1820 °C (-328...3308 °F)		
			E	-200...800 °C (-328...1472 °F)		
			T	-200...400 °C (-328...752 °F)		
			N	-200...1300 °C (-328...2372 °F)		
			C	0...2315 °C (32...4199 °F)		
Input range	1MΩ min	50Ωmax	1MΩ min			
Sample duration time	Software configurable: 10 ms or 100 ms per enabled channel		100 ms per enabled channel			
Input type	Single-ended input.					
Operation mode	Self-scan					
Conversion mode	Sigma delta ADC					

Input Characteristics

Characteristic	Value					
Signal type	Voltage	Current	Thermocouple		3-wire-RTD	
Max accuracy at ambient 25 °C (77 °F)	±0.1 % of full scale		±0.1 % of full scale		±0.1 % of full scale	
			Except:			
			R	±6.0 °C		
			S	(0...200 °C) (±10.8 °F (32...392 °F))		
			B	Not available (0...300 °C (32...572 °F))		
			K	±0.4 % of full		
			J	scale under 0 °C		
			E	(32 °F)		
			T			
			N			
Temperature drift	±0.006 % of full scale					
Repeatability after stabilization time	±0.5 % of full scale					
Nonlinearity	±0.1 % of full scale					
Maximum input deviation	±1.0 % of full scale					
Resolution	16 bits, or 15 bits + sign (65536 points)		K	15000 points	PT100	10500 points
			J	12000 points	PT1000	8000 points
			R	17600 points	NI100	2400 points
			S	17600 points	NI1000	2400 points
			B	18200 points		
			E	10000 points		
			T	6000 points		
			N	15000 points		
			C	23150 points		
Input value of LSB	0.15 mV (range 0...10 Vdc)	0.30 µA (range 0...20 mA)	0.1 °C (0.18 °F)			
	0.30 mV (range -10...+10 Vdc)	0.244 µA (range 4...20 mA)				

Input Characteristics (Continue)

Characteristic		Value			
Signal type		Voltage	Current	Thermocouple	3-wire-RTD
Data type in application program		Scalable from -32768 to 32767			
Input data out of range detection		Yes			
Noise resistance	Maximum temporary deviation during perturbations	±4 % maximum when EMC perturbation is applied to the power and I/O wiring			
	Cable	Twisted pair shielded cable, max 30 m			
	Crosstalk	1LSB max			
Isolation	Between output and internal logic	1500 Vac			
	Between input group and output group	500 Vac			
	Between inputs	Not isolated			
Maximum continuous allowed overload (no damage)		13 Vdc	40mA	N/A	
Input filter		Software filter: 0...10 s (per 0.01 s unit)			
Behavior when temperature sensor is broken		N/A		Input value is highest limit value Highest limit flag is ON	
Behavior when external power is off		Input value is 0		Input value is highest limit value	
		The External power supply error status bit in the controller is ON.			

Output Characteristic

Characteristic		Value	
		Voltage Output	Current Output
Output range		0...10Vdc -10...+10Vdc	0...20mA 4...20mA
Load impedance		1k Ω min	300 Ω max
Application load type		Resistive load	
Setting time		1ms	
Max accuracy at ambient 25 °C (77 °F)		± 0.2 % of full scale	
Temperature drift		± 0.01 % of full scale	
Repeatability after stabilization time		± 0.4 % of full scale	
Nonlinearity		± 0.2 % of full scale	
Output ripple		20 mV max	
Overshoot		0%	
Maximum output deviation		± 1.0 % of full scale	
Resolution		12 bits (4096 points)	
Input value of LSB		2.44mV (range 0...10 Vdc) 2.88mV (range -10...+10 Vdc)	4.88 μ A (range 0...20 mA) 3.91 μ A (range 4...20 mA)
Data type in application program		0...4095 (range 0...10 Vdc) -2048...+2047(range -10...+10 Vdc)	0...4095
		Scalable from -32768 to 32767	
Input data out of range detection		Yes	
Noise resistance	Maximum temporary deviation during perturbations	± 4 % maximum when EMC perturbation is applied to the power and I/O wiring	
	Cable	Twisted pair shielded cable, max 30 m	
	Crosstalk	1LSB max	
Isolation	Between output and internal logic	1500 Vac	
	Between input group and output group	500 Vac	
Output protection		Short- circuit protection	Open- circuit protection
Behavior when external power is off		The External power supply error status bit in the controller is ON.	

Dimension & Wiring Diagram (TM3TM3 / TM3TM3G)

<p>mm in.</p> <p>Connector</p> <p>LED</p>	LED	Color	Green
		Status LED	
		On: Activated	

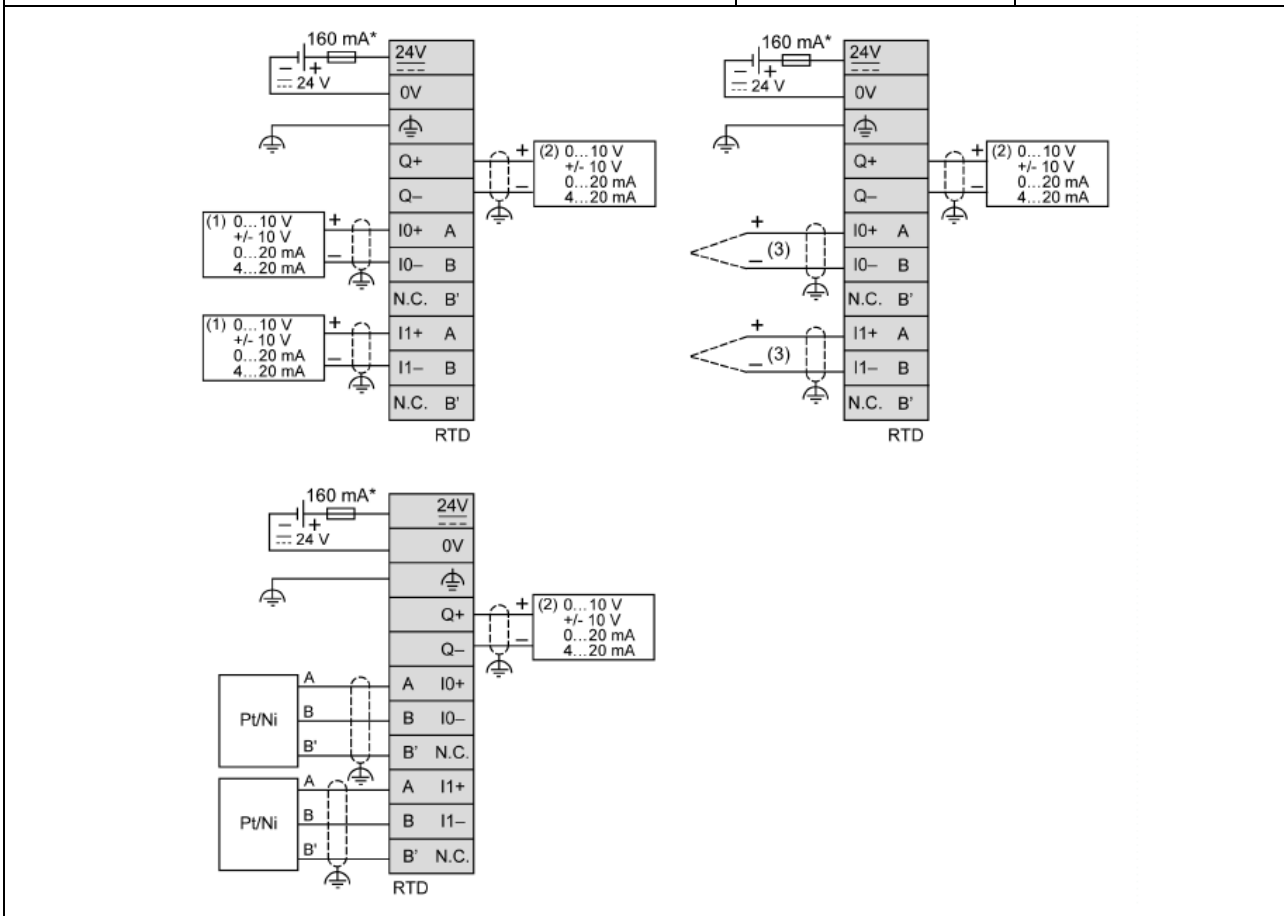

* Type T fuse

(1) Current/Voltage analog output device

(2) Current/Voltage analog input device

(3) Thermocouple

Do not connect wires to unused terminals and/or terminals indicated as "No Connection (N.C.)".

12.8.2 TM3AM6 /TM3AM6G

General Characteristics

Characteristic	Value
Rated power supply voltage	24 Vdc
Power supply range	20.4...28.8 Vdc
Connector insertion/removal durability	100 times minimum
Current draw on 5 Vdc internal bus	40 mA (all outputs on), 50 mA (all outputs off)
Current draw on 24 Vdc internal bus	0 mA
Current draw on external 24 Vdc	55 mA (all outputs on), 100 mA (all outputs off)

Input Characteristics

Characteristic	Value	
Signal type	Voltage input	Current input
Input range	0...10Vdc -10...+10Vdc	0...20 mA 4...20 mA
Input range	1M Ω min	50 Ω max
Sample duration time	Software configurable: 1 ms or 10 ms per channel	
Input type	Single-ended input.	
Operation mode	Self-scan	
Conversion mode	Sigma delta ADC	
Max accuracy at ambient 25 °C (77 °F)	\pm 0.2 % of full scale	
Temperature drift	\pm 0.01 % of full scale	
Repeatability after stabilization time	\pm 0.5 % of full scale	
Nonlinearity	\pm 0.2 % of full scale	
Maximum input deviation	\pm 1.0 % of full scale	
Resolution	12 bits (4096 points)	
Input value of LSB	2.44 mV (range 0...10 Vdc) 4.88 mV (range -10...+10 Vdc)	4.88 μ A (range 0...20 mA) 3.91 μ A (range 4...20 mA)
Data type in application program	Scalable from -32768 to 32767	
Input data out of range detection	Yes	

Characteristic		Value	
Signal type		Voltage input	Current input
Noise resistance	Maximum temporary deviation during perturbations	±4 % maximum when EMC perturbation is applied to the power and I/O wiring	
	Cable	Twisted pair shielded cable, max 30 m	
	Crosstalk	1LSB max	
Isolation	Between output and internal logic	1500 Vac	
	Between input group and output group	500 Vac	
	Between inputs	Not isolated	
Maximum continuous allowed overload (no damage)		13 Vdc	40mA
Input filter		Software filter: 0...10 s (per 0.01 s unit)	
Behavior when external power is off		Input value is 0 The External power supply error status bit in the controller is ON.	

Output Characteristics

Characteristic		Value	
		Voltage Output	Current Output
Output range		0...10Vdc -10...+10Vdc	0...20mA 4...20mA
Load impedance		1kΩ min	300Ω max
Application load type		Resistive load	
Setting time		1ms	
Max accuracy at ambient 25 °C (77 °F)		±0.2 % of full scale	
Temperature drift		±0.01 % of full scale	
Repeatability after stabilization time		±0.4 % of full scale	
Nonlinearity		±0.2 % of full scale	
Output ripple		20 mV max	
Overshoot		0%	
Maximum output deviation		±1.0 % of full scale	
Resolution		12 bits (4096 points)	
Input value of LSB		2.44mV (range 0...10 Vdc) 2.88mV (range -10...+10 Vdc)	4.88μA (range 0...20 mA) 3.91μA (range 4...20 mA)
Data type in application program		0...4095 (range 0...10 Vdc) -2048...+2047 (range -10...+10 Vdc)	0...4095
		Scalable from -32768 to 32767	
Input data out of range detection		Yes	
Noise resistance	Maximum temporary deviation during perturbations	±4 % maximum when EMC perturbation is applied to the power and I/O wiring	
	Cable	Twisted pair shielded cable, max 30 m	
	Crosstalk	1LSB max	
Isolation	Between output and internal logic	1500 Vac	
	Between input group and output group	500 Vac	
Output protection		Short- circuit protection	Open- circuit protection
Behavior when external power is off		The External power supply error status bit in the controller is ON.	

Dimension & Wiring Diagram (TM3AM6 /TM3AM6G)

<p>mm in.</p> <p>14,6 0,57</p> <p>70 2,76</p> <p>3,8 0,15</p> <p>23,6 0,93</p> <p>LED</p> <p>90 3,54</p> <p>5* 0,20</p> <p>Connector</p>	<p>LED</p> <p>Color</p> <p>Green</p> <p>Status LED</p> <p>On: Activated</p> <p>Off: Disactivated</p>
<p>160 mA*</p> <p>24 V</p> <p>24V</p> <p>0V</p> <p>Q0+</p> <p>Q0-</p> <p>Q1+</p> <p>Q1-</p> <p>I0+</p> <p>I0-</p> <p>N.C.</p> <p>(1) 0...10 V +/- 10 V 0...20 mA 4...20 mA</p> <p>(2) 0...10 V +/- 10 V 0...20 mA 4...20 mA</p> <p>(2) 0...10 V +/- 10 V 0...20 mA 4...20 mA</p> <p>(1) 0...10 V +/- 10 V 0...20 mA 4...20 mA</p> <p>(1) 0...10 V +/- 10 V 0...20 mA 4...20 mA</p> <p>(1) 0...10 V +/- 10 V 0...20 mA 4...20 mA</p> <p>N.C.</p> <p>I1+</p> <p>I1-</p> <p>N.C.</p> <p>I2+</p> <p>I2-</p> <p>N.C.</p> <p>I3+</p> <p>I3-</p> <p>N.C.</p>	<p>* Type T fuse</p>
<p>(1) Current/Voltage analog output device</p> <p>(2) Current/Voltage analog input device</p> <p>Do not connect wires to unused terminals and/or terminals indicated as "No Connection (N.C.)".</p>	