

1400 Series

Industrial Mini-PC System without
Integrated Display

P/N 128753-001(C)

Revision	Description	Date
A	Manual Released	4/98
B	Manual Updated	5/98
C	Updated to 1400	12/99

Trademark Information

Brand or product names are registered trademarks of their respective owners. Windows is a registered trademark of Microsoft Corp. in the United States and other countries.

Copyright Information

This document is copyrighted by Xycom Incorporated (Xycom) and shall not be reproduced or copied without expressed written authorization from Xycom.

The information contained within this document is subject to change without notice.

United States FCC Part 15, Subpart B, Class A EMI Compliance Statement:

Note: This equipment has been tested and found to comply with the limits for a Class A digital device, pursuant to part 15 of the FCC Rules. These limits are designed to provide reasonable protection against harmful interference when the equipment is operated in a commercial environment. This equipment generates, uses, and can radiate radio frequency energy and, if not installed and used in accordance with the instruction manual, may cause harmful interference to radio communications. Operation of this equipment in a residential area is likely to cause harmful interference in which case users will be required to correct the interference at their expense.

For European Users - WARNING

This is a Class A product. In a domestic environment, this product may cause radio interference. In such cases, users may be required to take adequate measures.

INSTALLATION: ELECTROMAGNETIC COMPATIBILITY WARNING

The connection of non-shielded equipment interface cables to this equipment will invalidate FCC EMI and European Union EMC compliance, and may result in electromagnetic interference and/or susceptibility levels that violate regulations that apply to the legal operation of this device. It is the responsibility of system integrators and/or users to apply the following directions relating to installation and configuration:

1. All interface cables must include shielded cables. Braid/foil type shields are recommended. Communication cable connectors must be metal, ideally zinc die-cast backshell types, and provide 360 degree protection about the interface wires. The cable shield braid must be terminated directly to the metal connector shell: ground drain wires alone are not adequate.
2. Protective measures for power and interface cables as described within this manual must be applied. Do not leave cables connected to unused interfaces or disconnected at one end. Changes or modifications to this device not expressly approved by the manufacturer could void the user's authority to operate the equipment.
3. EMC compliance is, in part, a function of PCB design. Third-party, add-on AT/XT peripheral PCB assemblies installed within this apparatus may void EMC compliance. FCC/CE compliant PCB assemblies should always be used where possible. Xycom can accept no responsibility for the EMC performance of this apparatus after system integrator/user installation of PCB assemblies not manufactured and/or expressly tested and approved for compliance by Xycom. It is the responsibility of the system integrator/user to ensure that installation and operation of such devices does not void EMC compliance.

Table of Contents

Chapter 1 – System Overview	3
Standard Features.....	3
Optional Features.....	4
Unpacking the System	5
Quick Start-up.....	5
Chapter 2 – Testing	6
Preparing for the Tests.....	6
Running the Tests	8
Chapter 3 – Installation	10
1400 Unit Mounting Plate.....	10
I/O Panel.....	10
1400 Unit I/O Panel.....	11
Back Panel.....	13
Power Panel	13
1400 Unit Power Panel	14
Installing Internal Hardware Options.....	14
DRAM Single In-line Memory Modules (SIMMs).....	14
PC/104 Boards	14
Installing External Hardware Options.....	16
External Floppy Drive.....	16
Serial Mouse	16
Installing Operating Systems	17
Installing Ethernet Drivers	17
Installing Video Drivers.....	18
Creating a Power Cable	18
AC Power Cable	18
DC Power Cable	20
Installing the System into a Panel	21
System Power.....	21
Excessive Heat	22
Electrical Noise.....	22
Line Voltage Variation.....	22
Mounting Considerations	23
Mounting the Unit.....	23
System Cutout Dimensions	24
Power Supply.....	25
AC Power Supply.....	25
DC Power Supply	25
Expansion Power	26
Hazardous Location Installations.....	26
Definitions	27
Group Ratings	29
Enclosures.....	29
Power Switch	30
Cable Connections	30

Operation and Maintenance	30
Safety Agency Approval	31
Chapter 4 – Maintenance	32
Preventive Maintenance	32
Replacing the Fuse	32
Chemical Compatibility	33
Compatible Lubricants	34
Compatible Cleaning Agents	35
Non-compatible Cleaning Agents	35
Spare Parts	35
Product Repair Program/Returning a Unit to Xycom	36
Appendix A – Technical Specifications	37
Hardware Specifications	37
Environmental Specifications	38
Appendix B – Pinouts	39
Parallel Port Connector	39
PS/2 Keyboard Connector	40
Mouse Port Connector	40
External Floppy Drive Connector	41
Power Connector	41
Ethernet Connector	41
COM1 Connector	42
RS-232 Connector	42
RS-485 Connection	42
COM2 Connector	43
Video Connector – 1400 Units	44
Appendix C – Installing the IDE Flash Drive	45
Installing the IDE Flash Drive	45
Configuring the IDE Flash Drive	46

Chapter 1 – System Overview

The 1400 Industrial Mini-PCs are basically “node box” versions of the 3400 system.

The units feature an open architecture to meet a variety of applications requiring both a powerful PC and a durable industrial enclosure.

The units’ processor board combines all the functions of an IBM PC/AT-compatible computer on an industrially-hardened circuit board. Refer to the Xycom CPU manual for more information on processor and hardware features.

Standard Features

The units offer the following standard features:

- 3.6-inch mounting depth
- CHIP4e+ board, which supports the latest 5x86 technology
 - 133 MHz AMD5x86 processor
 - 72-pin EDO DRAM SIMM site support (4, 8, 16, 32, and 64 Mbytes)
 - PCI 64-bit video controller, 1-Mbyte video RAM
 - PCI-bus IDE controller
 - 10BASE-T/100 BASE-TX Ethernet controller

Note

Refer to the board manual for more information on the system’s Ethernet capabilities.

- Numerous I/O ports
 - RS-232 and RS-232/RS-485 COM ports
 - Parallel port
 - VGA port (1400 only)
 - PS/2 mouse and keyboard ports
 - IrDA-compatible infrared port

- AC input power
- Flash BIOS
- External floppy connector
- PC/104 expansion site, allowing you to stack two PC/104 boards
- Status LEDs: Power, Disk, and COM and Input
- MS-DOS[®] (MS-DOS is not included if you order Windows[®] 95 or Windows NT[™])
- NEMA 4/4X/12 sealed front panel
- Class I, Division 2 hazardous location approval (pending)

Optional Features

The following optional features are available:

- Windows 95 or Windows NT preinstalled
- Hot installable external floppy drive
- 24-volt DC power supply
- Various IDE Flash drives
- NEMA 4-sealed panel-mount door for front access to keyboard and external floppy port connectors (with mounting hardware)

Unpacking the System

When you remove the system from its box, verify that you have the parts listed below. Save the box and inner wrapping in the event you need to reship the unit.

- 1400 unit
- Documentation kit:
 - Power connector
 - Diagnostic software disk (MS-DOS units only)
 - Eight 8-32 hex nuts
 - Cable clamp and screw (for strain relief of power cord)
 - Four standoffs and four 4-40 screws for mounting PC/104 expansion cards
 - 1400 Series Industrial Mini-PC System manual (CD ROM)
 - CPU manual (CD ROM)
 - Utility disks
- Business reply card

Quick Start-up

This section provides the steps to get the system operating, without explaining system capabilities and options.

Warning

Disconnect the power cord before making any adjustments to the inside or outside of the computer.

Perform the following steps to prepare the system for use:

1. Attach optional equipment following the instructions in Chapter 3.
2. Attach the power cord from the power receptacle to a properly grounded 90-250 VAC, 50-60 Hz outlet or 24 VDC outlet, whichever applies. (See Chapter 3, *Creating a Power Cable*.)
3. Turn on power to the unit. The system will boot up into the operating system.
5. Install application software via the external floppy, the network, or the IR port.

Chapter 2 – Testing

If your system ships with MS-DOS, Xycom provides diagnostic tests to verify system hardware functions. If a test fails, either you do not have the correct default setting or there has been a hardware failure. Check the default settings and run the tests again. If another failure occurs, contact Xycom Automation's Product Repair and Customization Department (see Chapter 6).

Note

Unexpected failures may occur if you run Xycom diagnostics with device drivers or memory resident programs (TSRs) installed on the system. Remove these before running any diagnostic tests.

Make sure the BIOS setup menus are configured properly (default settings). To access the setup menus,

- Press F2 after the memory tests.
- Make the necessary changes by following the on-screen directions.
- Press ESC.
- Press ENTER twice to save the setup and exit.

Refer to your CPU manual for more information on the BIOS setup menus.

Preparing for the Tests

You need the following equipment to test your system:

- Floppy disk drive
- IBM PC/AT or PS/2-compatible keyboard
- 3.5-inch, DS/DD (bootable) Xycom system test disk (Xycom part number 99290-001)
- Centronics-compatible printer cable
- Parallel printer (Centronics-style interface)
- Two serial loopback test connectors (refer to Figure 2-1 for pinouts)
- 3.5-inch, DS/HD (1.44 MB) disk, formatted

Perform the following steps before starting the tests:

1. Place the CPU board jumpers to the factory-set positions. Refer to your CPU manual for these settings.
2. Plug the female end of the AC power cable into the bottom of the unit and the male end into a properly grounded outlet.

3. Connect the serial loopback connector(s) and the printer cable to the appropriate connectors and connect a PC/AT or PS/2 keyboard. Figure 2-1. Serial Loopback Connections illustrates the wiring necessary for the loopback connection.

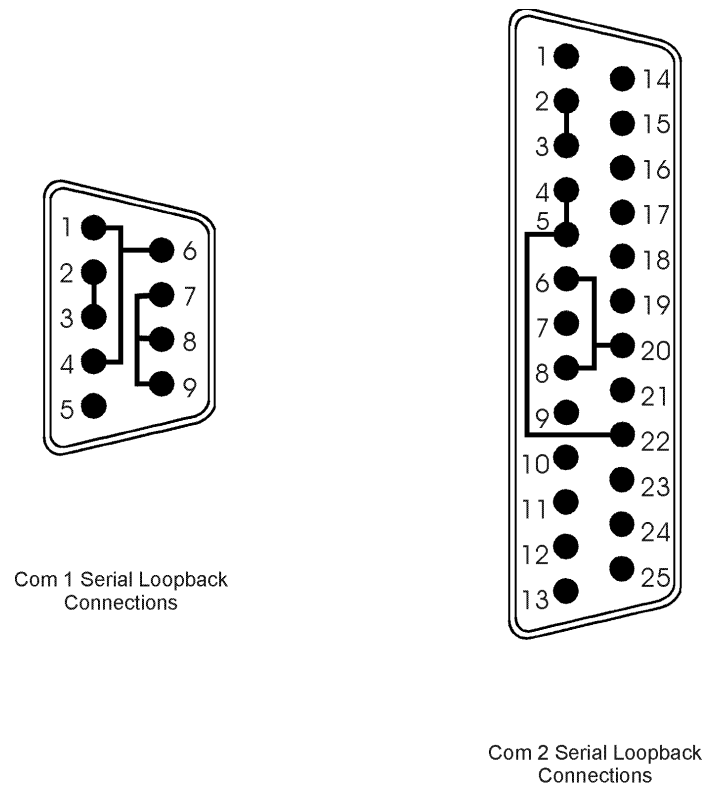

Figure 2-1. Serial Loopback Connections

4. Make sure the BIOS setup menus are set to the default settings.

Running the Tests

To run the tests, insert the diagnostics disk into drive A. Turn on the computer (the diagnostics program will boot-up). Figure 2-2 illustrates the Main Menu.

```
Copyright 1990-1996, Xycom, Inc. All rights reserved.

Diagnostic Tests Sequence/Selection Menu (Rel. xx)

1. WILL pause on error                5. Auto-select tests
2. SINGLE PASS test mode              6. Deselect all tests
3. Save setup to file                 7. Quit and exit to DOS
4. Extract setup from a file          8. Return to previous screen

A) RAM Test                           K) Video Interface Test
B) Video RAM Test                      L) Speaker Port Test
C) Extended RAM Test                  M) LPT1: Printer Port Test
D) Real Time Clock Test               N) LPT2: Printer Port Test
E) COM1 Serial Port Test              O) C: Hard Drive Interface Test
F) COM2 Serial Port Test              P) D: Hard Drive Interface Test
G) COM3 Serial Port Test              Q) A: Floppy Drive Interface Test
H) COM4 Serial Port Test              R) B: Floppy Drive Interface Test
I) Math Coprocessor Test              S) Keyboard, Keypad Tests
J) Video Adjustments Test             = = Test Selected

[ENTER]=START TESTING

Use the letters to move the cursor and select/deselect, or use the arrow keys to move, then
use the [SPACE] key to select/deselect a test or function.
```

Figure 2-2. Main Menu

Note

Please read the DIAG.TXT file on the diagnostics disk for detailed information about the tests.

Chapter 3 – Installation

This chapter describes how to install the 1400 systems and their available options.

1400 Unit Mounting Plate

The 1400 unit has a front mounting plate providing both threaded and unthreaded mounting options, as shown in Figure 3-1.

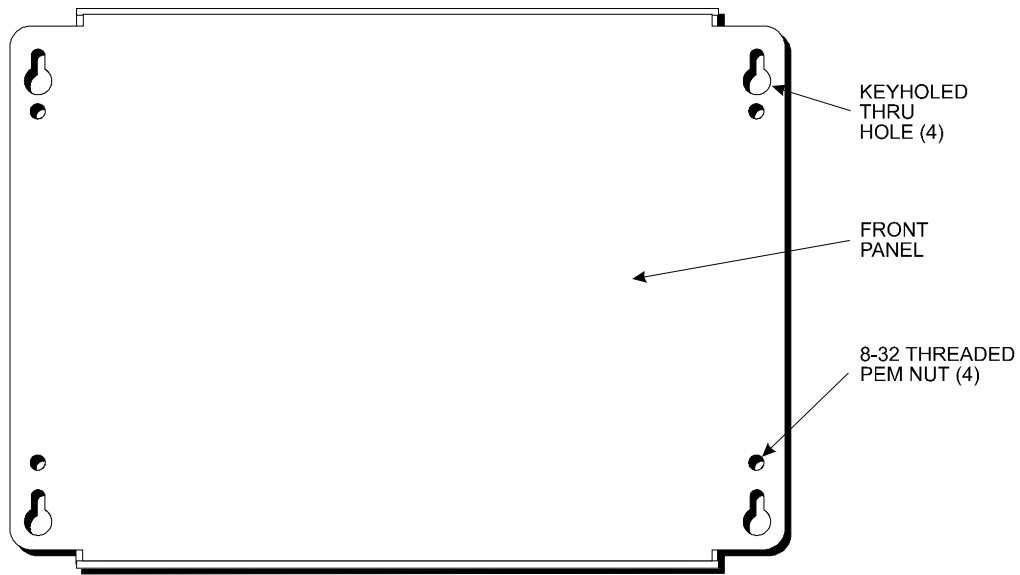

Figure 3-1. 1400 Unit Front End Mounting Plate

Feature	Description
Threaded Pem Nuts	The mounting plate offers four 8-32 threaded pem nuts, allowing the use of through holes on the mounting surface.
Keyholed Through Holes	The mounting plate offers four keyholed through holes, allowing the use of a nut and bolt combination or a bolt into a threaded mounting surface.

I/O Panel

This section describes the I/O panel on the 1400 units.

Warning

To maintain safe conditions, *never* use an external keyboard or mouse port when the units are operating in a hazardous environment.

1400 Unit I/O Panel

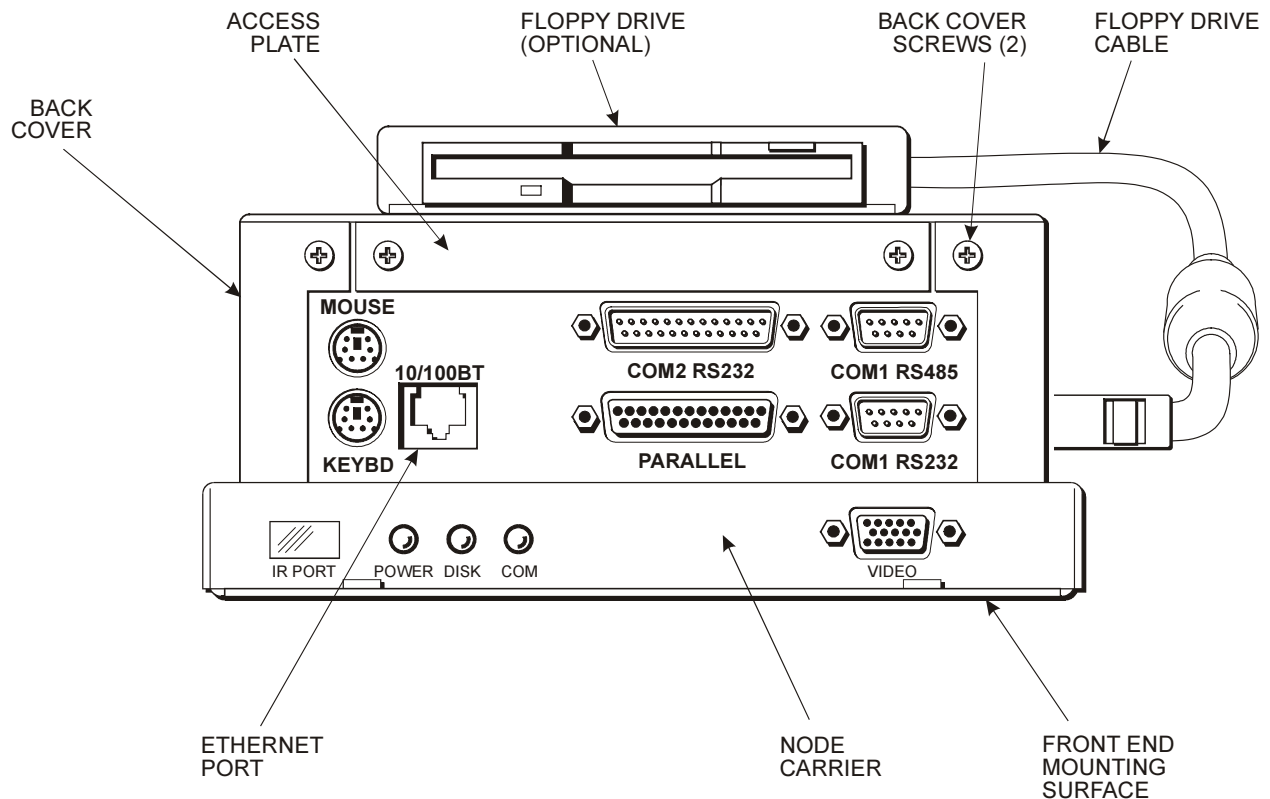

Figure 3-2. 1400 Unit I/O Panel

Feature	Description
Parallel port (LPT1)	This port provides a standard PC-compatible printer interface.
COM1 port	COM1 is RS-232/485 compatible. The nine-pin lower connector is RS-232. The upper connector is the RS-485 version of the same port. Only one of these connectors can be at a time since they are attached to the same logical port.
COM2 port	COM2 is dedicated to the IR port or the 25-pin connector. Only one option can be used at a time. An external pushbutton reset option is available. Consult the CPU board manual for the jumper that controls this option.
Ethernet port	This port provides a 10BASE-T/100BASE-TX autosensing Ethernet connection.
Keyboard port	This port allows you to attach a PS/2-style keyboard.
Mouse port	This port allows the attachment of a PS/2-style mouse.
IR (Infrared) Port	This port is IrDA and ASKIR compliant, allowing the connection of the unit to any IrDA-compatible device. Special software must be loaded (not included) to use this feature. When enabled through the BIOS setup menus, the IR link is designed to operate at a distance of 0 to 1 meter. <i>Note: COM2 is not available for other use when you select the IR port in the BIOS setup menus.</i>
Diagnostic LEDs	<p>Power On (green) when there is power to the unit.</p> <p>Disk On (green) when the computer module is accessing the disk drive.</p> <p>COM On (green) when there is communication on one of the computer module's serial ports, including a serial mouse.</p>

Feature	Description
Video port	This port allows the connection of a CRT to the 1400 unit. Refer to the jumper settings in the Xycom Automation CPU manual for information on enabling this connector.

Note

A pointing device using the auxiliary port may not operate reliably in conjunction with an 84-key keyboard. Use of this combination is not recommended.

Warning

To maintain safe conditions, *never* use an external keyboard or mouse port when the unit is operating in a hazardous environment.

Back Panel

Figure 3-3 illustrates the back panel on the 1400 units.

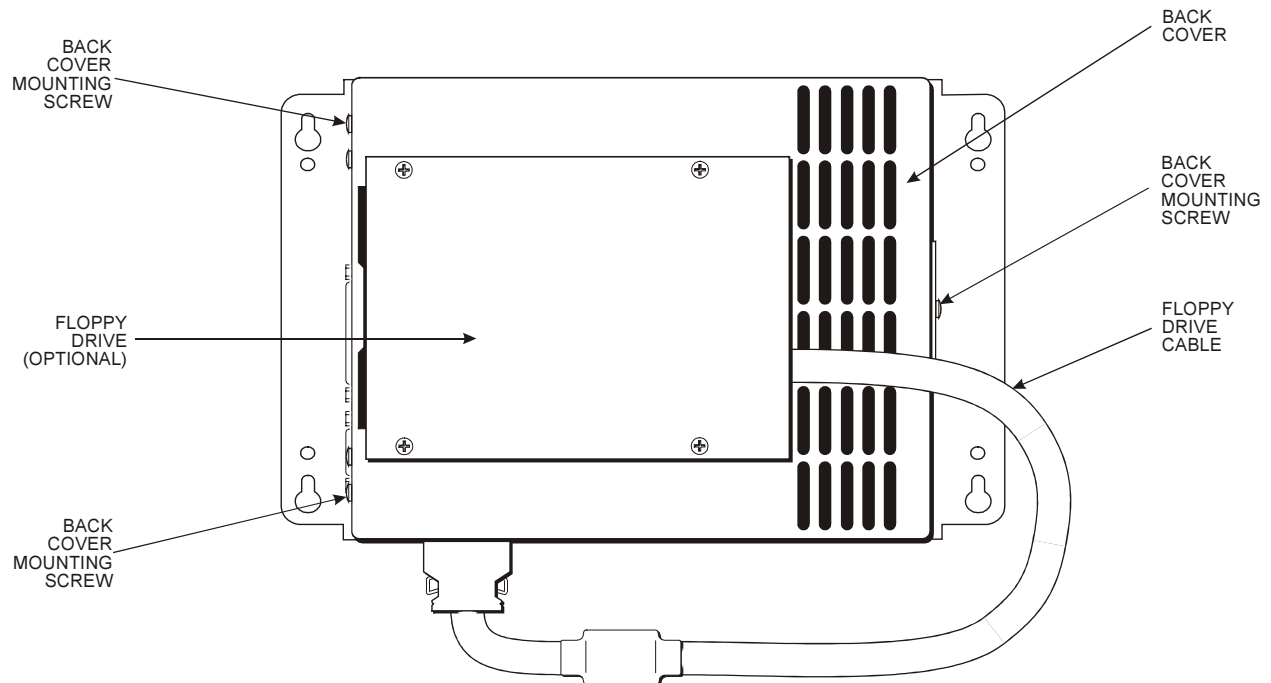

Figure 3-3. 1400 Unit Back Panel

Warning

Always disconnect the power cable, floppy cable, and any other external cables connected to the unit before removing the back cover.

Feature	Description
Back cover	The back cover has five notches that slide into corresponding slots on the mounting panel, as well as three screws that secure it to the unit.
External floppy disk drive (optional)	An external floppy disk drive may be installed to the back of the unit. It connects to the floppy connector on the bottom of the unit.

Power Panel

This section describes the power panels on the 1400 units.

1400 Unit Power Panel

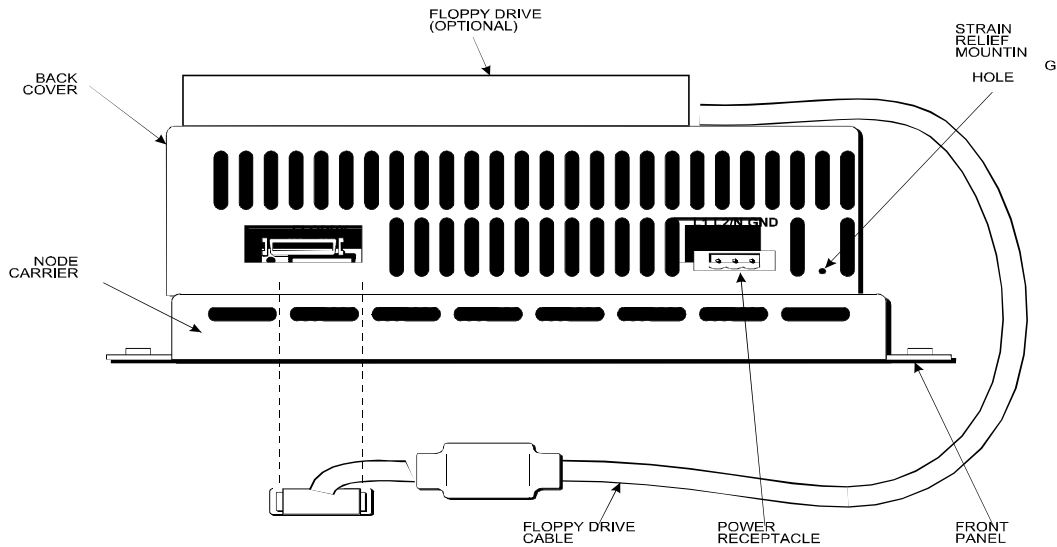

Figure 3-4. 1400 Unit Power Panel

Feature	Description
Power connector	The power receptacle is a three-pin connector. Refer to Hazardous Location Installations section later in this chapter for special installation instructions.
External floppy drive connector	The 26-pin floppy drive connector allows a connection to an optional external floppy drive.

Installing Internal Hardware Options

Warning

Always disconnect the power cable, floppy cable, and any other external cables connected to the unit before removing the back cover.

DRAM Single In-line Memory Modules (SIMMs)

You can order your system CPU factory-configured for many DRAM configurations. You can reconfigure DRAM capacity by changing the DRAM SIMMs on your CPU board. For more information, refer to the CPU manual.

PC/104 Boards

The PC/104 connector supports a 16-bit interface. The connectors are placed on the board so that PC/104 stack-through interface boards can be used.

Four standoffs are already attached to the CPU board. If you want to stack a second PC/104 card on the first, you need the four standoffs contained in the documentation kit.

Note

Installation of PC/104 cards may void EMC and hazardous locations compliance. This is a function of the PC/104 card design. It is the system integrator/user's responsibility to verify compliance before installing any given card.

Note

To prevent vibration failures, always use the locking screw to attach PC/104 cards.

Perform the following steps to install the PC/104 card:

1. Disconnect the power cable, floppy cable, and any other external cables.
2. On a protective surface, lay the unit on its front mounting surface.
3. Unscrew the three back cover mounting screws.
4. Slide the back cover toward the I/O panel, and lift off.
5. Attach the PC/104 card to the four preinstalled standoffs. If you want to install a second PC/104 card, you must attach the standoffs included in the documentation kit to the first PC/104 card.
6. If you need to connect the cards to something outside the unit, remove the access plate on the I/O panel. You can then pass cables through this area.

Installing External Hardware Options

This section explains how to install external hardware options.

External Floppy Drive

Note

To avoid corruption, do not attach the external floppy drive with a disk installed.

There are four screw holes on the back of the unit to mount an external floppy disk drive (9000-EXF). Refer to Figure 3-3.

Note

Make sure the floppy drive cable is able to reach the external floppy connector on the system before making the cutout.

Note

A pointing device using the auxiliary port may not operate reliably in conjunction with an 84-key keyboard. Use of this combination is not recommended.

Note

These keyboards are not available in the EU at this time (there is no CE mark).

Serial Mouse

To install Xycom Automation's 4100-MS1 two-button serial mouse, attach the connector on the mouse cable to COM1 or COM2 on the side panel.

Warning

To maintain safe conditions, do *not* use the external keyboard or mouse ports when the units are operating in hazardous environments.

Installing Operating Systems

The system comes with MS-DOS. You can also order the system preinstalled with Windows 3.11, Windows 95, or Windows NT. Table 3-1 indicates the formats in which preinstalled operating systems are provided.

Table 3-1. Operating System Formats

Operating Systems	Format
DOS	Disk
Windows 95	CD ROM or Disk
Windows NT	CD ROM

If you want to install a new operating system or re-install a current operating system, refer to the operating system's manual for directions.

Note

An external CD-ROM drive may be required to load additional drivers on Windows NT-equipped systems.

Installing Ethernet Drivers

If Windows 95 or Windows NT 4.0 is pre-installed on your system, Ethernet drivers are installed on your hard drive in the C:\netdrv directory.

Note

If you want to use Ethernet capabilities with Windows 95, your system must have BIOS revision level 1.1 or higher.

If MS-DOS is installed on your system, the Ethernet drivers are supplied on your hard drive in the C:\netdrv directory, but they are not installed.

To install the MS-DOS Ethernet drivers,

1. At the C: prompt, type "cd netdrv".
2. Once the C:\netdrv path is specified, type "setup".
3. Follow the on-screen instructions to complete installation.

If you install Windows 3.1 on your system, Xycom provides the Ethernet drivers. They can be found on the Intel 558 Ethernet Drivers disk that ships with your system. Refer to the Mswfw311.txt file in the A:\Info\Ms directory on this disk for installation information.

Note

If you install Windows NT 4.0 on your system, the Ethernet drivers that are provided with Windows NT 4.0 do not work with the Ethernet controller on 1400 units. You must use the drivers provided by Xycom.

These drivers can be found on the Intel 558 Ethernet Drivers disk that ships with your system. Refer to the Msnt40.txt file in the A:\Info\Ms directory on this disk for installation information.

Consult the Info directory on the drivers disk for additional installation information.

Installing Video Drivers

Video drivers and the expansion utilities are on the disk included with the documentation kit as well as on the hard drive.

The video drivers are in the following directories for systems with DOS:

C:\VGA\C&T550\WIN31
C:\VGA\C&T550\WIN95
C:\VGA\C&T550\WINNT
C:\VGA\C&T\DOS\UTILITIES

The appropriate drivers are copied to the hard drive under C:\VIDDRV for systems with Windows 95 or Windows NT installed.

Warning

Always disconnect the power cable, floppy cable, and any other external cables connected to the unit before removing the back cover.

Creating a Power Cable

This section describes how to create both an AC and a DC power cable.

AC Power Cable

An AC power cable must be to supply power to units with AC power supplies. You will need the following materials:

- A three-position power connector (supplied).
- A braid/foil shielded power cable, terminated at power source end, with three 18 (1.0 mm), 16 (1.3 mm), or 14 (1.6 mm) AWG solid or stranded copper wire, rated 80° C or better.

Perform the following steps to create the cable:

1. Cut the wire cable to the desired length.

2. Strip 0.25-inch (6 mm) of insulation from the end of the conductor wire. No bare wire should be exposed when the cable is connected to the workstation.
3. Tin the wire ends with solder if using stranded wire. This will keep the wire from fraying.

Warning

When inserting the wire ends of the power cable into the block plug, be sure there is no exposed wire. Trim the wire ends of the cable or cut a new cable if necessary.

4. Insert the three wire ends of the power cable into the three holes of the block plug. Insert the Protective Earth GND ground, L1, and L2/N wires into the corresponding holes, as shown in Figure 3-5. Be sure that no bare wires are exposed.

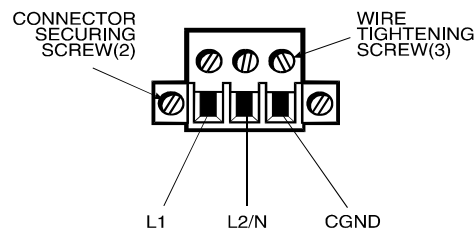

Figure 3-5. AC Power Connector

5. Tighten the three screws above the wires to hold them firmly in place.

Warning

Never tighten the three screws of the block plug when the cable is connected to a power source. The screws are conductive and have full contact with the cable wire.

6. Use a cable clamp and #6-32 screw (provided) to secure and provide strain relief to the power cable. When installing the power cable to the unit, use the securing screws on each side of the plug. This strain relief is mandatory for hazardous locations compliance.

Warning

Be sure to completely loosen the two securing screws on the plug when disconnecting the power cord from the unit.

DC Power Cable

You must create a DC power cable to supply power to units with DC power supplies. You will need the following materials:

- A three-position power connector (supplied)
- A braid/foil shielded power cable with three 18 (1.0 mm), 16 (1.3 mm), or 14 (1.6 mm) AWG solid or stranded copper wire, rated 80° C or better.

Perform the following steps to create the cable:

1. Cut the wire cable to the desired length.
2. Strip 0.25-inch (6 mm) of insulation from the end of the conductor wire. No bare wire should be exposed when the cable is connected to the workstation.
3. Tin the wire ends with solder if using stranded wire. This will keep the wire from fraying.

Warning

When inserting the wire ends of the power cable into the block plug, be sure there is no exposed wire. Trim the wire ends of the cable or cut a new cable if necessary.

4. Insert the three wire ends of the power cable into the three holes of the block plug. Insert the Protective Earth GND ground, + (positive), and - (return) wires into the corresponding holes, as shown in Figure 3-6. Be sure that no bare wires are exposed.

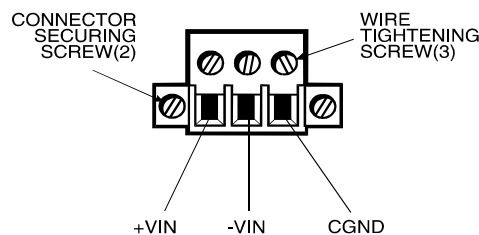

Figure 3-6. DC Power Connector

5. Tighten the three screws above the wires to hold them firmly in place.

Warning

Never tighten the three screws of the block plug when the cable is connected to a power source. The screws are conductive and have full contact with the cable wire.

6. Use the aluminum cable clamp (provided) to terminate the DC cable shield and provide strain relief. The aluminum cable clamp is designed to accommodate cable with ¼-inch (6.4 mm) O.D.

7. The DC cable shield must be terminated to chassis ground (PE) at the 1400 end. A pigtail termination will not provide enough EMI suppression in those installations where the DC cable exits a metal enclosure.

To terminate the braided cable shield, the braid must be dressed back over the cable insulation 1/2 inch (13 mm). The aluminum clamp must then be placed over the braid/insulation. Use the #6-32 screw (provided) to secure the clamp to the chassis in the female pem located on the side of the power connector opening. When installing the power cable to the unit, use the securing screws on each side of the plug.

Warning

Be sure to completely loosen the two securing screws on the plug when disconnecting the power cord from the unit.

Installing the System into a Panel

The system's rugged design allows it to be installed in most industrial environments. The system is generally placed in a NEMA 4/4X/12 enclosure to protect against contaminants such as dust, moisture, etc. Metal enclosures also help minimize the effects of electromagnetic radiation that nearby equipment can generate.

System Power

Using isolation transformers on the incoming AC power line to the system is always good practice. An isolation transformer is especially desirable in cases in which heavy equipment is likely to introduce noise onto the AC line. The isolation transformer can also serve as a step-down transformer to reduce the incoming line voltage to a desired level. The transformer should have a sufficient power rating (units of volt-amperes) to supply the load adequately.

Proper grounding is essential to all safe electrical installations. Refer to the relevant federal, state/provincial, and local electric codes which provide data such as the size and types of conductors, color codes and connections necessary for safe grounding of electrical components. The code specifies that a grounding path must be permanent (no solder), continuous, and able to safely conduct the ground-fault current in the system with minimal impedance (minimum wire required is 18 AWG, 1 mm).

Observe the following practices:

- Separate ground wires (P.E. or Protective Earth) from power wires at the point of entry to the enclosure. To minimize the ground wire length within the enclosure, locate the ground reference point near the point of entry for the plant power supply.
- All electrical racks or chassis and machine elements should be Earth Grounded in installations where high levels of electrical noise can be expected. The rack/chassis should be grounded with a ground rod or attached to a nearby Earth structure such as a steel support beam. Connect each different apparatus to a single Earth Ground point in a "star" configuration with low impedance cable. Scrape away paint and other nonconductive material from the area where a chassis makes contact with the enclosure. In addition to the ground connection made through the mounting bolt or

stud, use a one-inch metal braid or size #8 AWG wire to connect between each chassis and the enclosure at the mounting bolt or stud.

Excessive Heat

The systems withstand temperatures from 0° to 50° C. They are cooled by convection, in which a vertical column of air is drawn in an upward direction over the surface of its components. To keep the temperature in range, the cooling air at the base of the system must not exceed 50° C. Allocate proper spacing between internal components installed in the enclosure.

When the air temperature is higher than the specified maximum in the enclosure, use a fan or air conditioner to lower the temperature.

Electrical Noise

Electrical noise is seldom responsible for damaging components, unless extremely high energy or high voltage levels are present. However, noise can cause temporary malfunctions which can result in hazardous machine operation in certain applications. Noise may be present only at certain times, may appear as widely spread intervals, or in some cases may exist continuously.

Noise commonly enters through input, output, and power supply lines and may also be coupled through the capacitance between these lines and the noise signal carrier lines. This usually results from the presence of high voltage or long, close-spaced conductors. When control lines are closely spaced with lines carrying large currents, the coupling of magnetic fields can also occur. Use shielded cables to help minimize noise. Potential noise generators include switching components relays, solenoids, motors, and motor starters.

Refer to the relevant Federal, State/Provincial, and local electric codes which provide data such as the size and types of conductors, color codes and connections necessary for safe grounding of electrical components. It is recommended that high- and low-voltage cabling be separated and dressed apart. In particular, AC cables and switch wiring should not be in the same conduit with all communication cables.

Line Voltage Variation

The power supply section of the unit is built to sustain line fluctuations of 90-250 VAC and still allow the system to function within its operating margin. As long as the incoming voltage is adequate, the power supply provides all the logic voltages necessary to support the processor, memory, and I/O.

When the installation is subject to unusual AC line variations, use a constant voltage transformer to prevent the system from shutting down too often. However, a first step toward the solution of the line variations is to correct any possible feed problem in the distribution system. If this correction does not solve the problem, use a constant voltage transformer.

The constant voltage transformer stabilizes the input voltage to the systems by compensating for voltage changes at the primary in order to maintain a steady voltage at the sec-

ondary. When using a constant voltage transformer, check that the power rating is sufficient to supply the unit.

Mounting Considerations

Once you have established a location for the unit, consider the following when selecting an enclosure:

- Select a NEMA-rated enclosure, and place the unit to allow easy access to the system ports.
- Account for the unit's depth when choosing the depth of the enclosure.
- Provide a NEMA 4 seal by mounting the unit in an approved enclosure that has a 14 gauge (0.075"/1.9 mm thick) steel or (0.125"/3.2 mm thick) aluminum front face.
- Mount the unit in an upright position.
- Place the unit at a comfortable working level.
- Consider locations of accessories such as AC power outlets and lighting (interior lighting and windows) for installation and maintenance convenience.
- Prevent condensation by installing a thermostat-controlled heater or air conditioner.
- Avoid obstructing the air flow to allow for maximum cooling.
- Place any fans or blowers close to the heat-generating devices. If using a fan, make sure that outside air is not brought inside the enclosure unless a fabric or other reliable filter is used. This filtration prevents conductive particles or other harmful contaminants from entering the enclosure.
- Do not select a location near equipment that generates excessive electromagnetic interference (EMI) or radio frequency interface (RFI) (equipment such as high-power welding machines, induction heating equipment, and large motor starters).
- Do not place incoming power line devices (such as isolation or constant voltage transformers, local power disconnects, and surge suppressers) near the system. The proper location of incoming line devices keeps power wire runs as short as possible and minimizes electrical noise transmitted to the unit.
- Make sure the location does not exceed the unit's shock, vibration, and temperature specifications (refer to Appendix A for specifications).
- Install the unit in the panel in such a way as to ensure that it does not cause a hazard from uneven mechanical loading.
- Incorporate a readily accessible disconnect device in the fixed wiring on permanently connected equipment.
- Avoid overloading the supply circuit.

Mounting the Unit

Once the conditions in the preceding sections have been met, perform the following steps to mount the unit:

1. Locate a position for your system that meets the specifications required (see previous sections and Appendix A).
2. Create a panel cutout. Refer to the dimensions shown below.

3. Make sure the area around the cutout is clean and free from metal burrs.
4. Install the unit.
5. Attach one end of the power cord to the power receptacle and the other end to a properly grounded 90-250 VAC, 50-60 Hz or 24 VDC (on DC units) outlet, whichever applies. (see *Hazardous Location Installations* later in this chapter for more information).
6. Implement the proper grounding techniques. Establish a ground path from the unit chassis to the enclosure chassis. A 6-32 threaded ground point hole is provided on the bottom panel of the unit.
7. Tighten the eight #8-32 nuts on 1400 units to 16 inch-pounds (1.8 Newton-meters; 18 Kgf cm).
8. Turn on power to the unit. The system will boot up to the operating system installed.
9. Install application software via a floppy drive, the IR port, or a network.

System Cutout Dimensions

This section provides system cutout dimensions.

1400 Unit Cutout Dimensions

You can mount the 1400 unit in several different ways. Figure 3-7 provides mounting dimensions using a nut and bolt.

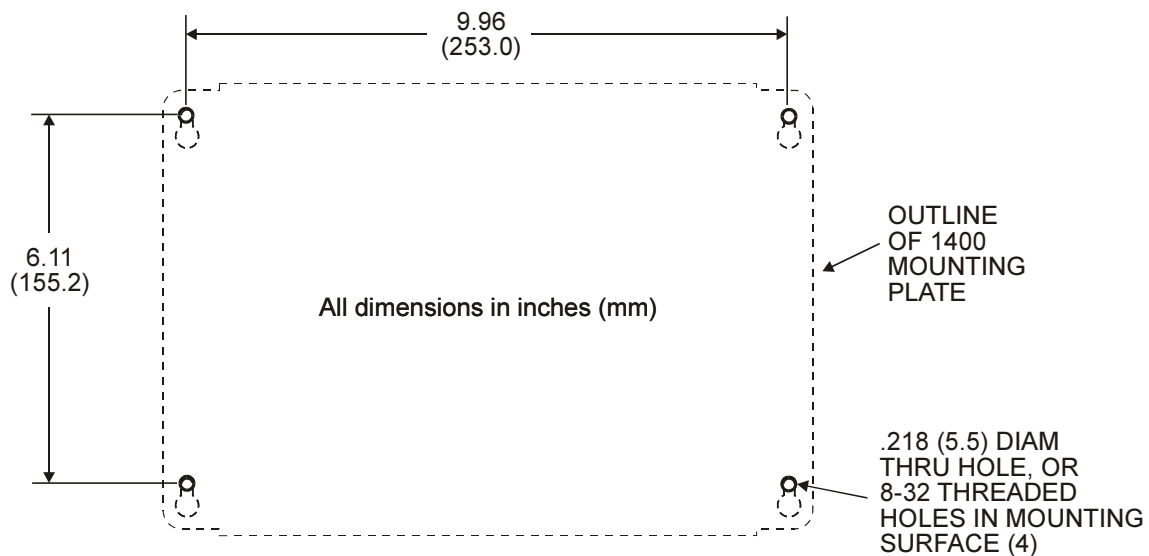

Figure 3-7. 1400 Unit Mounting Dimensions using Nut and Bolt

Figure 3-8 provides dimensions for mounting to the 8-32 threaded pem nuts installed in the mounting plate.

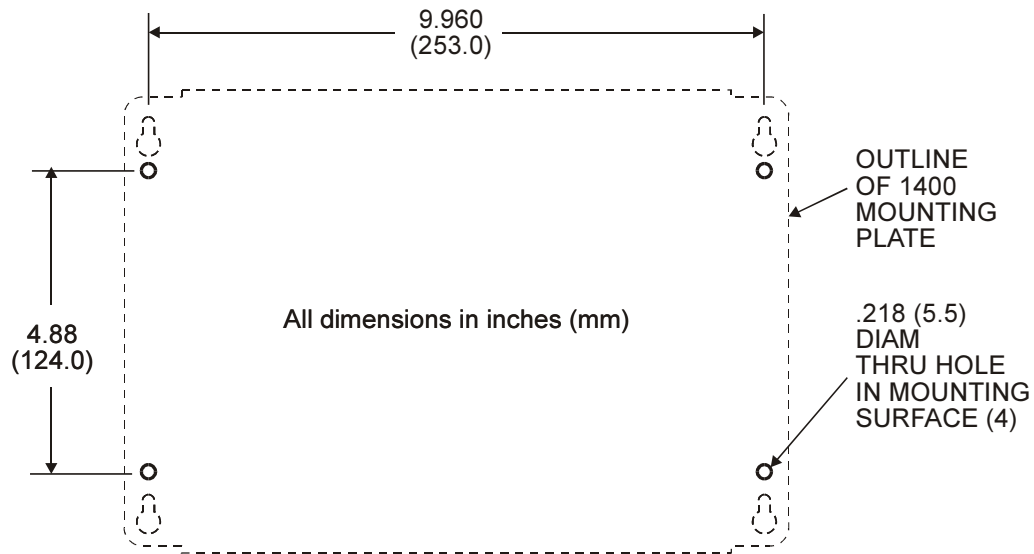

Figure 3-8. 1400 Unit Dimensions for Mounting to the 8-32 Threaded Pem Nuts

Power Supply

The standard systems ship with an AC power supply; a 24 VDC power supply is optional. This section provides specifications for both AC and DC power supplies.

AC Power Supply

The AC power supply provides 90-250 VAC, 50-60 Hz (autosensing), 1 A maximum at 90 VAC with 35 watts of output throughout the system's temperature range.

DC Power Supply

The DC power supply accepts +24 VDC input voltage for applications requiring DC input power. The factory-installed power supply module provides +5 V, +12 V, and -12 V outputs.

Electrical specifications for the power supply are 18 to 36 VDC, 2.5 A maximum at 18 volts.

Expansion Power

Table 3-2 lists the available power from both the AC and DC power supplies.

Table 3-2. Available Expansion Power

Voltage	CHIP4e+ Available Current
+5 V	.80 A
+12 V	.25 A
- 12 V	.25 A

Total not to exceed 6 W

Hazardous Location Installations

Xycom Automation has designed the systems to meet Class I, Division 2 Hazardous Location application requirements. Division 2 locations are locations that are normally non-hazardous, but could become hazardous due to accidents that may expose the area to flammable vapors, gases, or combustible dusts.

These systems have been designed as non-incendiary devices. They are not intrinsically safe and should never be operated within a Division 1 (normally hazardous) location when installed as described here. Nor should any peripheral interface device attached to these systems be located within Division 1 locations unless approved and/or certified diode barriers are placed in series with each individual signal and DC power line. Any such installations are beyond the bounds of Xycom design intent. Xycom accepts no responsibility for installations of this equipment or any devices attached to this equipment in Division 1 locations.

Note

When adding cards to the system, the user must ensure that they meet operating conditions for Class I, Division 2 hazardous locations.

It is the customer's responsibility to ensure that the product is properly rated for the location. If the intended location does not presently have a Class, Division, and Group rating, then users should consult the appropriate authorities having jurisdiction to determine the correct rating for that hazardous location.

In accordance with federal, state/provincial, and local regulations, all hazardous location installations should be inspected by the authority having jurisdiction, prior to use. Only technically qualified personnel should install, service, and inspect these systems.

Warning

Suitable for use in Class I, Division 2, Groups A, B, C, and D, and Class II, Division 2, Groups F and G hazardous locations or non-hazardous locations only.

Warning - Explosion Hazard

Substitution of components may impair suitability for Class I, Class II, Division 2.

Advertissement Risque D'Explosion

La substitution de composants peut rendre ce materiel inacceptable pour les emplacements de classe I, II, Division 2.

Warning - Explosion Hazard

Do not disconnect equipment unless the power has been disconnected or the area is known to be non-hazardous.

Advertissement Risque D' Explosion

Avant de deconnecter l'equipment, coupler le courant ou s'assurer que l'emplacement est designe non dangereux.

Advertissement Risque D' Explosion

Dans les situations hasardees, couper la courant avant de remplacer ou de cabler les modules.

Warning - Explosion Hazard

When operating in hazardous locations, disconnect power before replacing or wiring modules.

Warning

To maintain a safe condition, do *not* use an external keyboard or mouse when the unit is operating in a hazardous environment.

Definitions

The following Class and Division explanations are derived from Article 500 (Sections 5 and 6) of the United States National Fire Protection Agency National Electric Code (NFPA 70, 1990). They are not complete and are included here as a general description for those not familiar with generic hazardous location requirements.

People responsible for installing this equipment in hazardous locations are responsible for ensuring that all relevant codes and regulations related to location rating, enclosure, and wiring are met.

Class I Locations

Class I locations are those in which flammable gases or vapors are or may be present in the air in quantities sufficient to produce explosive or ignitable mixtures.

Class II Locations

Class II locations are those that are, or may become, hazardous because of the presence of combustible dust.

Division 1 Locations

Division 1 locations are those in which flammable or ignitable gases, vapors, or combustible dusts and particles can exist due to the following conditions:

- Normal operating conditions.
- Because of repair, maintenance conditions, leakage, or where mechanical failure or abnormal operation of machinery or equipment might release or cause explosive or ignitable mixtures to be released or produced.
- Combustible dusts of an electrically conductive nature may be present in hazardous quantities.

Note

Xycom systems are not suitable for installation within Division 1 locations.

Note

Electrical equipment cannot be installed in Division 1 locations unless it is intrinsically safe, installed inside approved explosion-proof enclosures, or installed inside approved purged and pressurized enclosures.

Division 2 Locations

Division 2 locations are listed below:

- Class I volatile flammable liquids or flammable gasses are handled, processed, or used, but confined within closed containers or closed systems from which they can escape only in cases of accidental rupture or breakdown of such enclosures or systems, or in case of abnormal operation of equipment.
- Ignitable concentrations of Class I vapors or gasses are normally prevented by positive mechanical ventilation, but which may become hazardous due to mechanical failure of those ventilation systems.
- Location is adjacent to a Division 1 location.

- Class II combustible dust is not normally in the air in quantities sufficient to produce explosive or ignitable mixtures. Dust accumulations are normally insufficient to interfere with normal operation of electrical equipment or other apparatus. Combustible dust may be in suspension in the air as a result of the following: infrequent malfunctioning of handling or processing equipment; combustible dust accumulations on, or in the vicinity of electrical equipment; may be ignitable by abnormal operation or failure of electrical equipment.

Group Ratings

All electrical equipment that is approved for use in hazardous locations must include a group rating. Various flammable and combustible substances are divided into these groups as a function of their individual maximum experimental safe gap (MESG), explosion pressure, and ignition temperature.

Component temperatures and the potential for spark based upon voltage, current, and circuit characteristics, within electrical equipment, will determine what the equipment group rating will be. A device approved for installation within Class I, Group A locations may also be used in Groups B, C, or D.

Note

Approved Class I equipment may not be suitable for Class II installations. Class I includes Groups A, B, C, and D. Class II includes Groups F and G.

Enclosures

The systems are designed to be installed within clean and dry enclosures for both ordinary and hazardous locations. The front panel meets the requirements of UL and CSA Type 4, 4X, and 12 enclosures. The enclosure used for Class I hazardous locations should have a minimum rating of Type 12 (NEMA 12, IP 5X). However, Type 4 (IP 6X) enclosures are strongly recommended.

Panel flatness and rigidity are important to maintain a proper panel seal. If you are going to use non-metal type enclosures, such as plastic or fiberglass, install a rigid metal stiffener behind the front panel. Failure to do so may result in an inadequate panel seal due to flexure of the front panel material between the stud mounts. Tighten the nuts on the mounting studs per the instructions in the previous section, “*Mounting the Unit.*”

Requirements for enclosure fittings, conduit, and wiring vary according to the specific rating of the location and the type of flammable or combustible material involved. Those requirements are beyond the scope of this document. It is the customer’s responsibility to ensure that the installation is compliant with codes and regulations that apply to the specific location. Reference NFPA 70, Article 500 for specific regulations in the United States.

Power Switch

The systems do not have a power switch. The amount of input power required by these systems classifies the power switch as an incendiary device because the voltage and current across the make/break device are capable of creating a spark.

Hazardous location regulations state that a power switch rated for ordinary locations may be used if it is located in a non-hazardous area. However, limits in cable length between the workstation and the power switch may apply. Otherwise, the switch must be compliant with Class I, Division 1 requirements (intrinsically safe). These switches are built in a manner that prevents the possibility of a spark when contacts are made or broken.

Use suitable UL-listed and/or CSA-certified Class I, Division 1 switches in hazardous locations. These switches are available from a number of sources. It is the customer's responsibility to ensure that the power switch selected for the installation has the correct hazardous location rating for the location in which it is installed.

Cable Connections

Division 2 hazardous location regulations require that all cable connections be provided with adequate strain relief and positive interlock. Never connect or disconnect a cable while power is applied at either end of the cable.

All communication cables should include a chassis ground shield. This shield should include both copper braid and aluminum foil. The D-sub style connector housing should be a metal conductive type (e.g., molded zinc), and the ground shield braid should be well terminated directly to the connector housing. Do not use a shield drain wire.

The outer diameter of the cable must be suited to the inner diameter of the cable connector strain relief to ensure that a reliable degree of strain relief is maintained. Always secure the D-Sub connectors to the workstation mating connectors via the two screws located on both sides.

Warning

Never connect or disconnect the communication cables while power is applied at either end of the cable. This may result in an incendiary spark. Permanent damage to the workstation communication components may occur.

Operation and Maintenance

The systems have been designed to comply with relevant spark ignition tests. However, the workstation front panel contrast adjustment tactile switches and keyboard connector are the only make/break components intended to be used by the operator in normal operation.

Warning

To maintain safe conditions, *never* use an external keyboard or mouse when the unit is operating in a hazardous environment.

Always observe the following rules with respect to hazardous location installations:

1. Always install the workstations within an enclosure suitable for the specific application. General purpose enclosures may be acceptable for Class I applications, but are never acceptable for Class II applications. Type 4 (IP 65) enclosures are recommended even when not required by regulations.
2. Keep enclosure doors or openings closed at all times to avoid the accumulation of foreign matter inside the workstation.
3. Never subject the unit to any installation or service procedures unless power is removed and the area is non-hazardous. This includes installing or removing power cables or communication cables, or removing the unit's back cover.
4. Only technically qualified service personnel should perform installation and service. These workstations are designed to require no service in the course of normal operation by an operator.

Safety Agency Approval

The 1400 systems have been designed to meet the following approvals:

- *Underwriters Laboratories Inc., UL 1604 Standard for Safety*
Electrical equipment for use in Class I and Class II, Division 2, and Class III hazardous (classified) locations
- *Underwriters Laboratories Inc., UL 1950*
Information Technology Equipment
- *Canadian Standard Association, Specification C22.2 No. 213-M1987*
Non-incendiary electrical equipment for use in Class I, Division 2 hazardous locations
- *Canadian Standards Association, Specification C22.2 No. 950*
Information Technology Equipment

Chapter 4 – Maintenance

The 1400 units are designed to withstand the harsh environment of the factory floor. However, preventive and routine maintenance will help keep the system in good operating condition.

Preventive Maintenance

Preventive maintenance consists of several basic procedures that will reduce the chance of system malfunction. Schedule preventive maintenance along with the regular equipment maintenance to minimize down time.

Following are some preventive measures you can take:

- Clean the screen using a non-residue cleaner such as a mild window cleaning solution or CRT screen cleaner. Take care not to scratch or mar the screen face.
- Base your maintenance schedule on the type of environment the system is in (i.e., if the area is dusty, schedule maintenance more often than if it is a dry, clean area).
- Remove dust and dirt from PC components. If dust builds up on heat sinks and circuitry, an obstruction of heat dissipation could cause the unit to malfunction. If dust reaches the electronic boards, a short circuit could occur.
- Check connections to I/O modules, especially in environments where shock could loosen the connections. Check all plugs, sockets, and module connections.
- Remove unnecessary articles, such as drawings or manuals, from the unit. They can obstruct air flow and create hot spots, which causes the system to malfunction.
- Do not place noise-generating equipment near the unit.
- Replace the module with the correct type. If the new module solves the problem but the failure reoccurs, check for inductive loads that may be generating voltage and current spikes and may require external suppression.

Replacing the Fuse

The 1400 units have no accessible fuse. Return the unit to Xycom Automation for fuse replacement.

Chemical Compatibility

Certain combinations of chemical environments, temperature, and stress can adversely affect parts made from thermoplastic resin. For this reason, material which may come in contact with 1400 units should be carefully evaluated under end-use conditions for compatibility. You should also follow the use and compatibility recommendations of the material manufacturer.

Table 4-1 lists general chemical compatibility guidelines.

Table 4-1. Chemical Compatibility

Chemical Class	Effects
Acids	No effect under most common conditions of concentration and temperature.
Alcohols	Generally compatible at low concentration and room temperature. Higher concentrations and elevated temperatures result in etching and attack evidenced by decomposition.
Alkalis	Generally compatible at low concentration and room temperature. Higher concentrations and elevated temperatures result in etching and attack evidenced by decomposition.
Aliphatic Hydrocarbons	Generally compatible
Amines	Surface crystallization and chemical attack. Avoid.
Aromatic Hydrocarbons	Partial solvents and severe stress cracking agents. Avoid.
Detergents and cleaners	Mild soap solutions are compatible. Strong alkaline materials should be avoided.
Esters	Causes severe crystallization. Partial solvents. Avoid.
Greases and oils	Pure petroleum types generally compatible. Many additives used with them are not compatible.
Halogenated Hydrocarbons	Solvents. Avoid.
Ketones	Causes severe crystallization and stress cracking. Partial solvents. Avoid.
Silicone oil and greases	Generally compatible up to 85° C (185° F). Some contain aromatic hydrocarbons which should be avoided.

Compatible Lubricants

Table 4-2 lists known compatible lubricants and the manufacturers' names. If you want to use a lubricant that is not listed in the table, contact the appropriate manufacturer to determine compatibility.

Table 4-2. Compatible Lubricants

Lubricants	Manufacturer
DC® 230 Molykote® 33	Dow Corning Midland, MI 48640 (800) 248-2345
Harmony® 68 Security® 68	Gulf Oil Petroleum Prod. Dept. Pittsburgh, PA 15230 (412) 655-6247
Lubriplate® Aero	Fisher Bros. Refinery 129 Lockwood Street Newark, NJ 07105
Martemp® 2500	E.F. Houghton & Co. 303 W. Lehigh Ave. Philadelphia, PA 19133 (215) 666-4000
Nyogel® 795A Rheolube® 368 Rheolube® 723G Rheolube® 788 Synthetic Oil® 181	Wm. J Nye P.O. Box G-927 New Bedford, MA 02742 (617) 966-6721
SF® 1147 Versilube® F-50	GE Silicone Products Waterford, NY 12188 (518) 237-3330
Terrestic ® 77	Exxon P.O. Box 2180 Houston, TX 77092 (713) 680-5712

Compatible Cleaning Agents

Table 4-3 lists known compatible cleaning agents. If you want to use a cleaning agent that is not listed in the table, contact the appropriate manufacturer to determine compatibility.

Table 4-3. Compatible Cleaning Agents

Type	Agents
Aliphatics	Hexane, Heptane, White Kerosene Mineral Spirits, Petroleum Ethers (65° C boiling point)
Alcohols	Methyl, Isopropyl and Isobutyl, 1 + 3 Denatured Alcohol
Halogenated hydrocarbons	Freons TF & TE
Detergents and cleaners	Mild Soap and Water Solution, VM&P Naphtha Fantastik®, Windex®, Joy®, Top Job®, Mr. Clean®, Formula 409®

Compatible aliphatics, alcohols, and halogenated hydrocarbons should be used only for wiping or short-term immersion (less than 10 minutes). If parts are in complete immersion, remove all traces of solvent by forced-air drying or rinsing in hot water.

Non-compatible Cleaning Agents

Table 4-4 lists cleaning agents known to be detrimental.

Table 4-4. Non-Compatible Cleaning Agents

Type	Agents
Bases	25% Ammonium Hydroxide, 10% Potassium Hydroxide, Sodium Hydroxide
Organic Solvents	Lacquer Thinner, Toluene, Methyl Cellosolve, Methylketone

Spare Parts

Stock spare parts to minimize down time resulting from part failure. The spare parts stocked should be 10 percent of the number of each unit used. Main CPU cards should have one spare each. Each power supply should have a back-up. In applications where immediate operation of a failed system is required, you may need to stock an entire spare computer module.

Table 4-5 provides a list of spare parts along with their Xycom Automation part numbers.

Table 4-5. 1400 Unit Spare Parts List

Description	Xycom Automation Part Number
Hard Drive	
2.1 GB hard drive (kit)	137365-001
16 MB flash drive (kit)	139443-001
24 MB flash drive (kit)	139677-001
48 MB flash drive (kit)	139678-001
CHIP4e+ 133 MHz CPU board	130034-001
DRAM	
4M x 32 (16 Mbytes)	104302
8M x 32 (32 Mbytes)	106054
16M x 32 (64 Mbytes)	123514
AC Input Power Connector	99711-001
External Floppy Kit (9000-EXF)	116074-001

Product Repair Program/Returning a Unit to Xycom

Xycom Automation's Product Repair and Customization Department (PR&C) restores equipment to normal operating condition, and implements engineering changes that enhance operating specifications. Returned products are tested with standard Xycom test diagnostics.

Follow the steps below to prepare the unit for shipment:

1. Obtain an RMA number for your unit by calling your nearest Xycom Repair Department or Xycom Automation, Inc. at 1-800-289-9266 or 734-429-4971.

Please have the following information available:

- Company name and shipping and billing addresses.
 - Type of service desired: product repair or product exchange.
 - Product model number, part number, quantity, serial number(s), and warranty status.
 - Failure mode and failure systems.
 - Purchase order number or repair order number.
2. Make sure the front panel assembly is properly attached to the unit.
 3. Attach failure information to the unit to speed processing.
 4. Place the unit securely in its original packaging or an equivalent heavy-duty box.
 5. Mark the RMA number on your purchase order and on the outside of the box.
 6. Send the unit to the address given when you receive your RMA number.

Appendix A – Technical Specifications

Hardware Specifications

Table A- 1. Hardware Specifications

Characteristic	Specification
Mechanical 1400 Height Width Length Weight	7.6" 10.7" 3.6" 7.5 lbs
Electrical AC Power DC Power	90 to 250 VAC, 50-60 Hz, autosensing 1A maximum at 90 VAC 18 to 36 V, 24 volts nominal 2.5 A maximum at 18 VDC
Power Supply	35 watts output
Available Power	With CHIP4e+ CPU board +5 V @ .8 A +12 V @ .25 A -12 V @ .25 A Total not to exceed 6 watts
Mounting	Panel Mount
Agency Approvals	UL 1950 UL 1604 CUL C22.2, No. 950 CUL C22.2, No. 213-M1987
Regulatory Compliance	FCC 47 CFR. Part 15, Class A CE EMI EN55022, Class A IMMUNITY EN50082-2:1995 SAFETY EN60950

Environmental Specifications

Table A- 2. Environmental Specifications

Characteristic	Specification
Temperature	
Operating	0° to 50° C (32° to 122° F)
Non-operating	-20° to 60°C (-4° to 140°F)
Humidity	
Operating	20% to 80% RH non-condensing
Non-operating	20% to 80% RH non-condensing
Altitude	
Operating	Sea level to 10,000 feet (3048 m)
Non-operating	Sea level to 40,000 feet (12192 m)
Vibration (<i>no rotating media</i>)	
Frequency	5 to 2000 Hz
Operating	0.006" peak-to-peak displacement 1.0g maximum acceleration
Non-operating	0.015" peak-to-peak displacement 2.5 g maximum acceleration
Shock (<i>no rotating media</i>)	
Operating	15g peak acceleration, 11 msec duration
Non-operating	30g peak acceleration, 11 msec duration

Appendix B – Pinouts

This appendix provides pinouts for the external connectors on the CHIP4e+ board.

Parallel Port Connector

This 25-pin DB connector supports ECP and EPP.

Pin	Signal
1	STROBE
2	PD(0)
3	PD(1)
4	PD(2)
5	PD(3)
6	PD(4)
7	PD(5)
8	PD(6)
9	PD(7)
10	PACK
11	PBUSY
12	PE
13	SELECT
14	AUTOFEED
15	PERROR
16	INIT
17	SELIN
18	GND
19	GND
20	GND
21	GND
22	GND
23	GND
24	GND
25	GND

PS/2 Keyboard Connector

This connector provides an external keyboard interface. This port uses a polyswitch to protect VCC from directly shorting to GND.

Pin	Signal
1	KB_DATA
2	NC
3	GND
4	5VFUSE
5	KB_CLK
6	NC

Warning

To maintain safe conditions, *never* use an external keyboard or mouse port when the unit is operating in a hazardous environment.

Mouse Port Connector

This connector provides an external mouse interface. This port uses a polyswitch to protect VCC from directly shorting to GND.

Pin	Signal
1	AUX_DATA
2	NC
3	GND
4	5VFUSE
5	AUX_CLK
6	NC

Warning

To maintain safe conditions, *never* use an external keyboard or mouse port when the unit is operating in a hazardous environment.

External Floppy Drive Connector

This 26-pin connector allows you to connect an external floppy. This port uses a poly-switch to protect VCC from directly shorting to GND.

Pin	Signal	Pin	Signal
1	+5V	14	FSTEP*
2	IDX*	15	NC
3	FDS1*	16	FWD*
4	+5V	17	GND
5	NC	18	FWE*
6	DCHG*	19	GND
7	NC	20	FTK0*
8	NC	21	GND
9	GND	22	FWP*
10	MO1*	23	GND
11	NC	24	FRDD*
12	FDIRC*	25	GND
13	NC	26	FHS*

Power Connector

This three-pin connector provides AC or DC input power to the unit.

Pin	AC Signal	DC Signal
1	L	+DC
2	N	-DC
3	AC_GND	GND

Ethernet Connector

This eight-pin connector provides 10BASE-T and 100BASE-TX Ethernet connections.

Pin	Signal
1	TX+
2	TX-
3	RX+
4	Short to pin 5 75ohm to TERMPANE
5	Short to pin 4 75ohm to TERMPANE
6	RX-
7	Short to pin 8 75ohm to TERMPANE
8	Short to pin 7 75ohm to TERMPANE

COM1 Connector

This nine-pin connector actually consists of two connectors (RS-232 and RS-485) attached to one logical port. Only one connector can be used at a time.

RS-232 Connector

The lower nine-pin connector provides the RS-232 protocol.

Pin	Signal
1	DCD1
2	RXD1
3	TXD1
4	DTR1
5	GND
6	DSR1
7	RTS1
8	CTS1
9	RI1

RS-485 Connection

The upper nine-pin connector provides the RS-485 protocol.

Pin	Signal
1	TXD-
2	TXD+
3	TXD TERM -
4	TXD TERM +
5	GND
6	RXD-
7	RXD+
8	RXD TERM +
9	RXD TERM -

Note

For TXD termination, connect a 150 Ω , 1/2-watt resistor from pin 3 to pin 4, with pin 1 connected to pin 3 and pin 2 connected to pin 4.

For RXD termination, connect a 150 Ω , 1/2-watt resistor from pin 8 to pin 9 with pin 6 connected to pin 9 and pin 7 connected to pin 8.

COM2 Connector

You can configure this port for use with one of two separate devices: the infrared (IR, IrDA) interface, or RS-232 connector. The BIOS setup determines whether COM2 is used for the RS-232 connector or the IR interface.

Pin	Signal
1	ORB_GND
2	TXD2
3	RXD2
4	RTS2
5	CTS2
6	DSR2
7	GND
8	DCD2
9	NC
10	NC
11	PB_RESET*
12	NC
13	NC
14	NC
15	NC
16	NC
17	NC
18	NC
19	NC
20	DTR2
21	NC
22	RI2
23	NC
24	NC
25	NC

This connector also contains the remote system reset option. A normally open pushbutton switch can be connected to pins 11 and 7. When the switch is pressed, the PB_RESET* signal is forced to GND, which causes the CPU to reset. To enable this option, you must set jumper J1 to position B.

Video Connector – 1400 Units

This 15-pin D-shell connector is enabled when J3 is set to B.

Pin	Signal
1	RED
2	GREEN
3	BLUE
4	NC
5	ORB_GND
6	ORB_GND
7	ORB_GND
8	ORB_GND
9	NC
10	ORB_GND
11	NC
12	NC
13	HSYNC
14	VSYNC
15	NC

Appendix C – Installing the IDE Flash Drive

As an additional storage option, you can install an IDE flash drive on your 1400 units.

Installing the IDE Flash Drive

Warning

Always disconnect the power cable and any other external cables connected to the unit, before removing the back cover.

Perform the following steps to replace the IDE Flash drive:

1. Disconnect the power cable, as well as any other external cables.
2. Unscrew the three back cover mounting screws (refer to the back panel Figure 3-3 in Chapter 3 if you need help locating these screws).
3. Slide the back cover toward the I/O panel, and lift off.
4. Loosen the four screws holding front panel.
5. Carefully lift off the front panel.
6. Flip the unit over to expose the flat-panel display.
7. Remove the four screws and lift off the hard drive.
8. Remove the Flash drive card by pushing down on the piece of metal and pulling out the card. Replace with the new Flash drive card, as shown in Figure C-1.

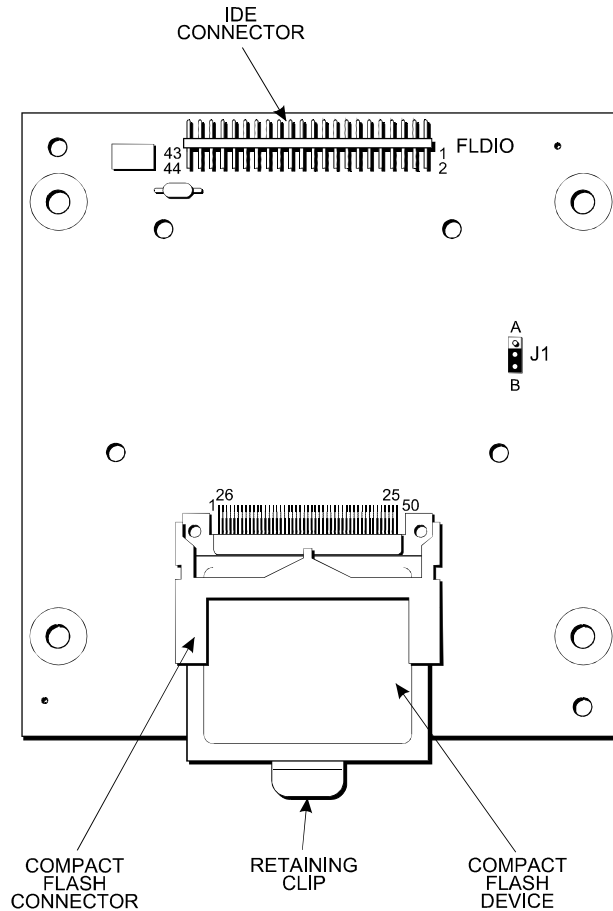

Figure C-1. IDE Flash Drive

13. Reverse the steps to reassemble the unit.

Configuring the IDE Flash Drive

Perform the following steps to configure the IDE Flash drive:

1. Press F2 to access the BIOS setup menus.
2. In the Main Menu, select the IDE Adapter 0 Master item, and press and press ENTER.
3. Highlight the Autotype Fixed Disk entry and press ENTER.
4. Next, press ESC to access the Exit menu.
5. Highlight the Save Changes & Exit entry, and press ENTER.

The Flash drive has been automatically configured.

INDEX

- 1400
 - back panel, 13
 - I/O panel, 11
 - IR port, 11
 - mounting plate, 10
 - power panel, 14
- AC power supply, 25
- agency approvals, 37
- altitude, 38
- back cover, 13
- back panel, 13
- boards, PC/104, 14
- cable connections, 30
- chemical compatibility, 33
 - cleaning agents, 35
 - lubricants, 34
 - non-compatible cleaning agents, 35
- cleaning agents
 - compatible, 35
 - non-compatible, 35
- COM1
 - connector, 42
- COM2
 - connector, 43
- connectors
 - COM1, 42
 - COM2, 43
 - Ethernet, 41
 - external floppy drive, 41
 - parallel port, 39
 - power, 14, 41
 - PS/2 keyboard port, 40
 - PS/2 mouse port, 40
 - serial loopback, 7
 - UART1. *See* COM1
 - UART2. *See* COM2
 - VGA, 44
 - video, 44
- creating a power cable, 18
- DC power supply, 25
- diagnostic tests
 - preparation, 6
 - running, 8
- DRAM, 14
- drivers
 - Ethernet, 17
 - video, 18
- drives, floppy disk, 13
- electrical specifications, 37
- enclosures, hazardous locations, 29
- environmental specifications, 38
 - altitude, 38
 - humidity, 38
 - shock, 38
 - temperature, 38
 - vibration, 38
- Ethernet connector, 41
- Ethernet drivers, 17
- expansion power, 26
- expansion, PC/104, 14
- external floppy drive
 - connector, 41
 - installation, 16
- fasteners, 13
- features
 - optional, 4
 - standard, 3
- floppy disk drive
 - external, 13
- fuse, replacing, 32
- group ratings, hazardous locations, 29
- hardware specifications, 37
- hazardous location definitions
 - Class I locations, 28
 - Class II locations, 28
 - Division 1 locations, 28
 - Division 2 locations, 28
- hazardous location installations, 26
- hazardous locations
 - cable connections, 30
 - enclosures, 29
 - group ratings, 29
 - maintenance, 30
 - operation, 30
 - power switch, 30
- heat, excessive, 22
- humidity, 38
- I/O panel
 - 1400, 11
- installation
 - DRAM, 14
 - external floppy drive, 16
 - external hardware, 16
 - hazardous locations, 26

- operating systems, 17
- panel, 21
- serial mouse, 16
- IR port
 - 1400, 11
- keyboard port, 11
- LEDs, 11
- line voltage variation, 22
- lubricants, compatible, 34
- maintenance, 32
 - cleaning the unit, 35
 - hazardous locations, 30
- mounting considerations, 23
- mounting plate, 1400, 10
- mounting the unit, 23, 37
- mouse port, 11
- mouse, serial, 16
- Noise, electrical, 22
- operating systems, installation, 17
- operation and maintenance, 30
- operation, hazardous locations, 30
- panel installation, 21
- parallel port connector, 39
- PC/104 boards, 14
- pinouts
 - COM1 connector, 42
 - COM2 connector, 43
 - Ethernet connector, 41
 - external floppy drive connector, 41
 - parallel port, 39
 - power connector, 41
 - PS/2 keyboard port, 40
 - PS/2 mouse port, 40
 - VGA connector, 44
 - video connector, 44
- ports
 - COM1, 11
 - COM2, 11
 - IR
 - 1400, 11
 - keyboard, 11
 - mouse, 11
- power
 - available, 37
 - cable, creating, 18
 - connector, 41
 - expansion, 26
 - supply
 - AC, 25
 - DC, 25
 - specifications, 37
 - switch, 30
 - system, 21
- power connector, 14
- power panel
 - 1400, 14
- power receptacle, 14
- product repair, 36
- PS/2 keyboard port connector, 40
- PS/2 mouse port connector, 40
- replacing
 - fuse, 32
- returning a unit, 36
- safety agency approval, 31
- serial loopback connections, 7
- serial mouse, installation, 16
- shock, 38
- SIMMs. *See* DRAM
- spare parts, 35
- specifications
 - electrical, 37
 - environmental, 38
 - hardware, 37
 - mechanical, 37
 - power supply, 37
- system power, 21
- temperature, 38
- UART1. *See* COM1. *See* COM1
- UART2. *See* COM2. *See* COM2
- unit, returning, 36
- VGA connector, 44
- vibration, 38
- video connector, 44
- video drivers, 18