

1546 Heavy-Duty Industrial PC without Integrated Display

DS-154600(C)



FEATURES

- Intel® Celeron® M 1.3 GHz, 512 cache, 400 MHz system bus (optional Pentium® M 2.0 GHz, 2M cache, 533 MHz system bus)
- Up to 2 GB DRAM (512 MB standard)
- 80 GB minimum Serial ATA hard drive (optional dual hard drives)
- 4X AGP graphics with 32 MB video memory (shared with system memory)
- Four available expansion slots:
 - ♦ One (8.0" max.) PCI expansion slot;
 - ♦ Two (9.0" max.) PCI expansion slots;
 - ♦ One (9.0" max.) PCI or ISA expansion slot
- 10/100, and 10/100/1000 BaseT Ethernet
- 4 USB 2.0 compliant ports (one additional 1.1 compliant port on front of KPM units)
- Three Serial Ports:
 - ♦ 2 RS-232;
 - ♦ 1 Selectable RS-232/422/485
- Rear accessible Type I/II CompactFlash™ socket
- DVD-R/W, and floppy drives
- UL, cUL, CE approvals
- UL listed for hazardous locations: Class I Division 2, Groups A, B, C, D; Class II Division 2, Groups F and G
- Windows® XP or Windows 2000 operating systems
- 100-240 VAC power supply
- 2-year warranty included

Pro-face America's newest generation of Xycom brand industrial PCs are designed and tested for the tough environments required for plant floor use. Our standard PC configurations meet the strict specifications required for use in hazardous locations and Europe's CE mark. Based on CPU boards designed specifically for industrial automation, these systems provide the capabilities required by demanding applications. With an installed base of over 300,000 systems, our industrial PC products are successfully applied in manufacturing and process environments world-wide.

Higher Performance, Lower Power

The 1546 utilizes an Intel mobile processor providing superior processing power while utilizing half the wattage of a comparable Pentium 4 processor. The optional Pentium M 2.0 GHz processor (2 M Cache & 533 MHz system bus) outperforms a desktop Pentium 4, 2.4 GHz (512 K Cache & 533 MHz bus) while utilizing less than half the wattage. The increased processing power with less heat generation makes the 1546 ideal for most factory automation applications requiring a NEMA enclosure. Less wattage input into the system results in less temperature rise in the enclosure. With less temperature rise the maximum ambi-

ent operating temperature is more easily maintained, possibly without the need for expensive enclosure cooling devices.

Superior Video Performance

The on-board 4X AGP graphics controller defaults to 4 MB system RAM to allow resolutions up to 1280 x 1024. In addition the 1546 automatically shares up to 32 MB system RAM to allow full 32-bit color depth and fast 3D rendering.

Fits Your Needs

The 1546 can be configured many different ways. With four available expansion slots many cost effective, industry standard op-

tions are easily integrated. The optional dual hard drive, externally accessible

CompactFlash, or RAID-enabled configuration provides the storage solution you require. Additionally the DVD-R/W drive provides even more storage and backup options.

Meets High Standards

To survive on the plant floor the 1546 meets FCC, UL, cUL, and European CE mark requirements for industrial automation equipment. Xycom Automation Industrial PCs lead the industry in reliability, service, and support with an optional five year warranty available.

With the cover removed expansion cards are easily installed in the 1546 without cumbersome cables to contend with.



Shelf Mounting



Wall Mounting



The 1546 unit has incorporated a simple to access hard drive mount. Simply loosen 2 captive screws and extract the hard drive. No cables to install or connect. Simply plug in the new drive. Optional dual hard drives or RAID-enabled configurations are also available.

The 1546 offers several data storage options. The standard unit contains a single Serial ATA hard drive. Dual hard drives are optional, as is a RAID-enabled configuration. Also, the externally accessible Type I/II CompactFlash can be ordered with the operating system pre-loaded for a solid state alternative. The 1546 offers a DVD-R/W, or a floppy for your choice of removable media drives. In addition, the 4 USB 2.0 ports can be utilized to add many commercially available external devices.

Externally Accessible Compact-Flash™



1546 Unit Dimensions

Model	1546
Height (A)	9.24" (234.7 mm)
Width (B)	11.47" (291.3 mm)
Width (C)	12.74" (324.9 mm)
Depth (D)	5.75" (146.1 mm)
Weight	13 lbs (7.2 kg)

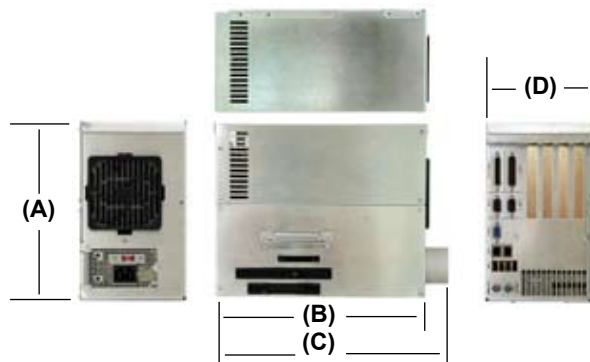

Model	1546
Processors	Intel® Celeron® M 1.3 GHz or optional Pentium M
Preloaded OS	Windows® XP or Windows® 2000 (multi-language)
Expansion	One (8.0" max.) PCI, two (9.0" max.) PCI, and one (9.0" max.) PCI or ISA

Shelf Mounting Wall Mounting

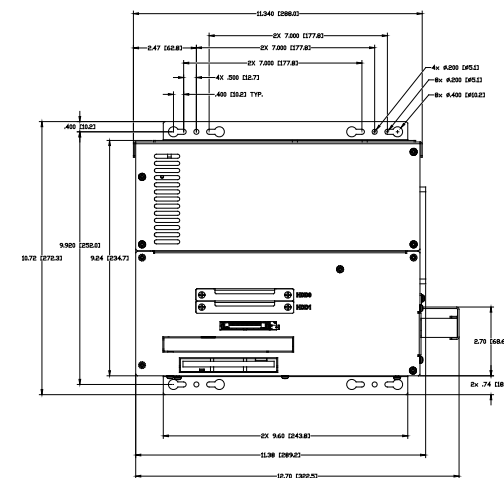
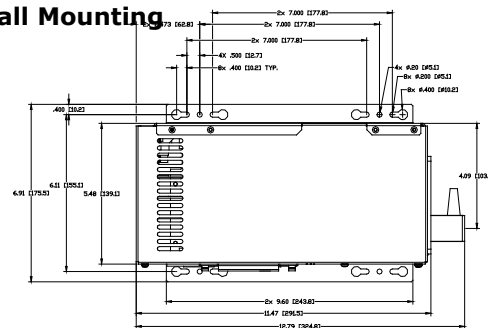

Environmental

	Operating	Nonoperating
Thermal	0°C to 50°C	-20°C to 60°C
Humidity	20% to 80% RH, noncondensing	20% to 80% RH, noncondensing
Shock ^a	15g peak acceleration, 11 msec duration	30g peak acceleration, 11 msec duration
Vibration 5-2000 Hz ^a	.006" peak to peak displacement 1.0g maximum acceleration	.015" peak to peak displacement 2.5g maximum acceleration
Altitude ^b	Sea level to 10,000 ft.	Sea level to 40,000 ft.

^a These values are with solid state hard drives and not rotating media drives.

^b Consistent with internal component specifications.

Electrical

Power Supply	250 Watt AC
AC Power	100-240 VAC, 50-60 Hz, 74 Watt nominal power [†]
Available Power	+3.3V 4.0A maximum
Expansion Power	+5V 4.0A maximum
	-5V 160mA maximum
	+12 3.0A maximum
	-12 240mA maximum

[†] Nominal Power is measured for a base configuration only. Any additional expansion and/or devices will increase the input power required.

Compliance

Regulatory Compliance:

- CE**
- EN 55022: Class A
 - EN 61000-6-2
 - EN61000-3-2, Class A
 - EN61000-3-3
 - IEC 60950-1

- FCC**
- 47 CFR, Part 15, Class A



Product certification documentation available at: www.xycom.com/certifications

Safety Agency Approvals:

- UL**
- UL 508 Listed
 - UL 1604 Listed ^a
- CUL**
- CSA-C22.2, #142 Listed
 - CSA-C22.2, #213 Listed ^a

^a Class I Division 2, Groups A, B, C, D; Class II, Division 2, Groups F and G; Temp. Code: T6

To create an order number, follow the conventions defined by the example order numbers and product configurations.

Example Order Number

Order Number	Description
1546-1300-512-DVDW-XP	1546 Industrial "Node" PC, Intel® Celeron® M 1.3 GHz CPU (512K Cache, 400 MHz bus), 512 MB DRAM, 80 GB minimum Serial ATA Hard Drive, Rear Access Type I/II CompactFlash socket, Windows XP, On-board 10/100 and 10/100/1000 BaseT Ethernet and USB, one (8.0" max.) PCI, two (9.0" max.) PCI and one (9.0" max.) PCI or ISA expansion slots.

1546 -

- CPU**
- 1300 Celeron M 1.3 GHz, 512K Cache, 400 MHz bus
 - 2000 Pentium M 2.0 GHz, 2M Cache, 533 MHz bus

- DRAM**
- 512 512 MB DRAM
 - 1000 1 GB DRAM
 - 2000 2 GB DRAM

- Internal Hard Drive**
- Blank Internal 80 GB (min.) Serial ATA Hard Drive
 - ND No Internal Hard Drive ^a
 - DHD Dual Internal 80 GB (min.) Serial ATA Hard Drives

- Rotating Media Drives ^c**
- Blank No Rear Access Media Drive
 - DVDW Rear Access Read/Write DVD-ROM Drive ^b

- Floppy**
- Blank No Floppy Installed ^c
 - F Rear Access Floppy Installed

- Externally Accessible CompactFlash**
- Blank Nothing Installed
 - 4GCF 4 GB CompactFlash Installed ^d

- Operating System**
- XP Pre-Activated Windows XP Professional
 - 2K Windows 2000 (multi-language)
 - NOS No Operating System loaded

^a 4GB CompactFlash option must be chosen when selecting the -ND option. ^b When ordering DVDW options and No Operating System all required drivers will not be loaded and devices will not function properly. ^c When ordering a unit with no floppy operating system recovery will not be possible without adding an external USB floppy drive. ^d When ordering CompactFlash and no internal hard drive the operating system will be loaded on the CompactFlash. This is not recommended when applications are storing data.

Important Notice for XP configurations: Certain Microsoft® software product(s) included with this computer may use technological measures for copy protection. IN SUCH EVENT, YOU WILL NOT BE ABLE TO USE THE PRODUCT IF YOU DO NOT FULLY COMPLY WITH THE PRODUCT ACTIVATION PROCEDURES. Product activation procedures and Microsoft's privacy policy will be detailed during initial launch of the product, or upon certain reinstallations of the software product(s) or reconfigurations of this computer, or may be completed by Internet or telephone (toll charges may apply).

Warranty Information
The 1546 series carries a two-year parts & labor warranty.

Pro-face America
Phone: 734.429.4971
Fax: 734.429.1010
www.profaceamerica.com

Customer Service Hotline: 734.944.0482

For more informa-
 www.profaceamerica.com





California Proposition 65 Warning—Lead and Lead Compounds

Advertencia de la Proposición 65 de California—Plomo y compuestos de plomo

Avertissement concernant la Proposition 65 de Californie—Plomb et composés de plomb

⚠ WARNING: This product can expose you to chemicals including lead and lead compounds, which are known to the State of California to cause cancer and birth defects or other reproductive harm. For more information go to: www.P65Warnings.ca.gov.

⚠ ADVERTENCIA: Este producto puede exponerle a químicos incluyendo plomo y compuestos de plomo, que es (son) conocido(s) por el Estado de California como causante(s) de cáncer y defectos de nacimiento u otros daños reproductivos. Para mayor información, visite : www.P65Warnings.ca.gov.

⚠ AVERTISSEMENT: Ce produit peut vous exposer à des agents chimiques, y compris plomb et composés de plomb, identifiés par l'État de Californie comme pouvant causer le cancer et des malformations congénitales ou autres troubles de l'appareil reproducteur. Pour de plus amples informations, prière de consulter: www.P65Warnings.ca.gov.

All trademarks are the property of Schneider Electric SE, its subsidiaries, and affiliated companies.

Schneider Electric USA, Inc.
800 Federal Street
Andover, MA 01810 USA
888-778-2733
www.schneider-electric.us

Todas las marcas comerciales son propiedad de Schneider Electric SE, sus filiales y compañías afiliadas.

Importado en México por:
Schneider Electric México, S.A. de C.V.
Av. Ejercito Nacional No. 904
Col. Palmas, Polanco 11560 México, D.F.
55-5804-5000
www.schneider-electric.com.mx

Toutes les marques commerciales sont la propriété de Schneider Electric SE, ses filiales et compagnies affiliées.

Schneider Electric Canada, Inc.
5985 McLaughlin Road
Mississauga, ON L5R 1B8 Canada
800-565-6699
www.schneider-electric.ca