

4117T

17" Light Duty Industrial PC

| Revision | Description | Date |
|-----------------|---|-------------|
| A | Manual Released | 9/06 |
| B | Name change, correct where applicable with document | 4/07 |

Part Number 144811 (B)

Trademark Information

Xycom and Xycom Automation are trademarks of Xycom Automation, L.L.C.

Xycom Automation, L.L.C. now is referred to as Pro-face through a D.B.A. The Pro-face name and logo will replace the Xycom name and logo on all documents where possible.

Pro-face is a trademark of Digital Electronics Corporation.

Brand or product names may be registered trademarks of their respective owners. Windows[®] is a registered trademark of Microsoft Co the United States and other countries.

Copyright Information

This document is copyrighted by Xycom Automation, L.L.C. (Xycom) and shall not be reproduced or copied without expressed written authorization from Xycom Automation, L.L.C.

The information contained within this document is subject to change without notice. Pro-face does not guarantee the accuracy of the information.

United States FCC Part 15, Subpart B, Class A EMI Compliance Statement:

NOTE: This equipment has been tested and found to comply with the limits for a Class A digital device, pursuant to part 15 of the FCC Rules. These limits are designed to provide reasonable protection against harmful interference when the equipment is operated in a commercial environment. This equipment generates, uses, and can radiate radio frequency energy and, if not installed and used in accordance with the instruction manual, may cause harmful interference to radio communications. Operation of this equipment in a residential area is likely to cause harmful interference in which case the user will be required to correct the interference at his or her own expense.

For European Users - WARNING:

This is a Class A product. In a domestic environment this product may cause radio interference in which case the user may be required to take adequate measures.

INSTALLATION: Electromagnetic Compatibility WARNING:

The connection of non-shielded equipment interface cables to this equipment will invalidate FCC EMI and European Union EMC compliance and may result in electromagnetic interference and/or susceptibility levels which are in violation of regulations applying to the legal operation of this device. It is the responsibility of the system integrator and/or user to apply the following directions relating to installation and configuration:

All interface cables must include shielded cables. Braid/foil type shields are recommended. Communication cable connectors must be metal, ideally zinc die-cast backshell types, and provide 360-degree protection about the interface wires. The cable shield braid must be terminated directly to the metal connector shell, ground drain wires alone are not adequate.

Protective measures for power and interface cables as described within this manual must be applied. Do not leave cables connected to unused interfaces or disconnected at one end. Changes or modifications to this device not expressly approved by the manufacturer could void the user's authority to operate the equipment.

EMC compliance is, in part, a function of PCB design. Third party add-on AT/XT peripheral PCB assemblies installed within this apparatus may void EMC compliance. FCC/CE compliant PCB assemblies should always be used where possible. PRO-FACE can accept no responsibility for the EMC performance of this apparatus after system integrator/user installation of PCB assemblies not manufactured and/or expressly tested and approved for compliance by PRO-FACE. It is the responsibility of the system integrator/user to ensure that installation and operation of such devices does not void EMC compliance.

Table of Contents

| | |
|---|-----------|
| CHAPTER 1 – INTRODUCTION | 1 |
| GENERAL INFORMATION | 1 |
| <i>Standard Features</i> | 1 |
| <i>LCD Display</i> | 2 |
| <i>Touch Screen</i> | 2 |
| FRONT AND SIDE PANELS | 4 |
| UNPACKING THE SYSTEM | 5 |
| QUICK STARTUP | 5 |
| CHAPTER 2 — INSTALLATION | 6 |
| INSTALLATION OVERVIEW | 6 |
| MECHANICAL DIMENSIONS | 8 |
| MOUNTING OPTIONS | 9 |
| <i>Panel Mounting</i> | 9 |
| <i>Wall Mounting</i> | 11 |
| <i>Arm Mounting</i> | 13 |
| CHAPTER 3 – ICPMB-7570 MOTHERBOARD..... | 14 |
| <i>ICPMB-7570 CPU Board</i> | 14 |
| <i>Product Overview</i> | 14 |
| <i>Specifications</i> | 14 |
| <i>Graphics Support</i> | 15 |
| <i>Display</i> | 15 |
| <i>Internal Graphics Features</i> | 15 |
| <i>Intel® Embedded Graphics Drivers</i> | 15 |
| ICPMB-7570E CPU BOARD LAYOUT | 16 |
| <i>Jumper Settings</i> | 17 |
| <i>JP2: Clear CMOS Setup</i> | 17 |
| <i>JP4: CF card setup</i> | 18 |
| <i>JP5: LCD voltage setup</i> | 18 |
| <i>JP6: RS-232/485 Setup(for COM3)</i> | 18 |
| <i>Connector Pin Outs</i> | 19 |
| AMI BIOS SETUP | 28 |
| <i>Starting Setup</i> | 28 |
| <i>Using Setup</i> | 30 |
| SETUP SUBMENU: MAIN | 30 |
| SETUP SUBMENU: ADVANCED..... | 31 |
| CPU CONFIGURATION | 32 |
| IDE CONFIGURATION | 33 |
| PRIMARY IDE MASTER | 34 |
| FLOPPY CONFIGURATION | 37 |
| SUPER I/O CONFIGURATION | 38 |
| H/W HEALTH CONFIGURATION | 40 |
| REMOTE ACCESS CONFIGURATION | 41 |
| USB CONFIGURATION | 42 |
| CHAPTER 4 – MAINTENANCE | 61 |
| GENERAL PREVENTIVE MAINTENANCE | 61 |
| <i>Fuse Replacement</i> | 61 |
| RECOMMENDED HARD DRIVE PREVENTIVE MAINTENANCE | 61 |
| PRODUCT REPAIR PROGRAM / RETURNING A UNIT TO PRO-FACE | 62 |
| CHAPTER 5 – TROUBLESHOOTING..... | 63 |
| DIAGNOSTIC TESTING | 63 |
| RUNNING THE TESTS | 65 |
| REINSTALLING OPERATING SYSTEMS | 66 |

Windows® 2000 Reinstallation.....66
Windows XP® Reinstallation66
 INSTALLING DRIVERS67
 Video Drivers67
 Touch Screen Drivers67
 Miscellaneous Drivers.....68
APPENDIX A TECHNICAL SPECIFICATIONS.....69
 HARDWARE SPECIFICATIONS69
 * NOMINAL POWER IS MEASURED FOR A BASE CONFIGURATION ONLY. ANY ADDITIONAL EXPANSION AND/OR
 DEVICES WILL INCREASE THE INPUT POWER REQUIRED. ENVIRONMENTAL SPECIFICATIONS69
 ENVIRONMENTAL SPECIFICATIONS70
APPENDIX B – POWER-ON SELF-TEST MESSAGES.....71
 POST MESSAGES71
 POST BEEP71
 ERROR MESSAGES.....71
APPENDIX C – HOW TO UPGRADE A NEW BIOS75
 BIOS UPDATE PROCEDURE.....75
 RECOVERING YOUR OLD BIOS76

Chapter 1 – Introduction

General Information

The 4117T 17" LCD TFT Panel PC, takes advantage of a modern flat-panel display, ICPMB-7560 CPU board, drive spaces and a power supply for minimum size. It is an IBM PC/AT® compatible computer specially designed to meet the applications for light duty environments.

Standard Features

The 4117T comes standard with the following features:

- ICPMB-7570 CPU board equipped with a high performance socket Pentium® M 1.4GHz CPU with 400 MHz front system bus and 2MB cache
- 4X AGP video controller
- 10/100 and 10/100/1000 Base T Ethernet ports
- 2 USB 2.0 ports
- Audio (in/out/mic)
- Three RS-232 serial ports
- Video, printer, and PS/2 ports
- 17" flat panel TFT XGA (1280 x 1024) LCD
- 100-240 VAC, 50-60 Hz power supply
- Analog resistive touch screen
- Internal 80GB hard disk drive
- Slim line CD-R/W with DVD-ROM drive
- 2 DDR 333 sockets, 512MB SDRAM DIMM
- 1 half-length of PCI expansion port
- AC power supply
- NEMA 4/4X/12 front panel
- RoHS compliant
- Windows® XP Operating System

Optional Features:

- DDR 333 1GB - 2GB SDRAM DIMM
- DVD +/-RW
- Windows® 2000 Operating System

LCD Display

Table 1-1 identifies the features of the 4117T LCD display.

Table 1-1. 4117T LCD Display Specifications

| Display Model | AUO |
|----------------|-----------------------|
| Display Type | 17" TFT color |
| Resolution | 1280 x 1024 |
| Maximum colors | 16.2M |
| Brightness | 300 cd/m ² |

Touch Screen

Table 1-2 identifies important specifications of the 4117T touch screen.

Table 1-2. 4117T Touch Screen Specifications

| Touch Screen Model | Description |
|--------------------|--|
| Screen Type | Eight wire analog resistive touch screen |
| Resolution | Continuous |
| Light Transmission | Typical value 75% |
| Surface Hardness | 4H (Test condition: ASTM D3363-92A) |
| Support Driver | Supports Windows 2000/XP |

The figures on the next several pages show the internal and external components on the front and back panels of the unit to help you locate features relevant to installation.

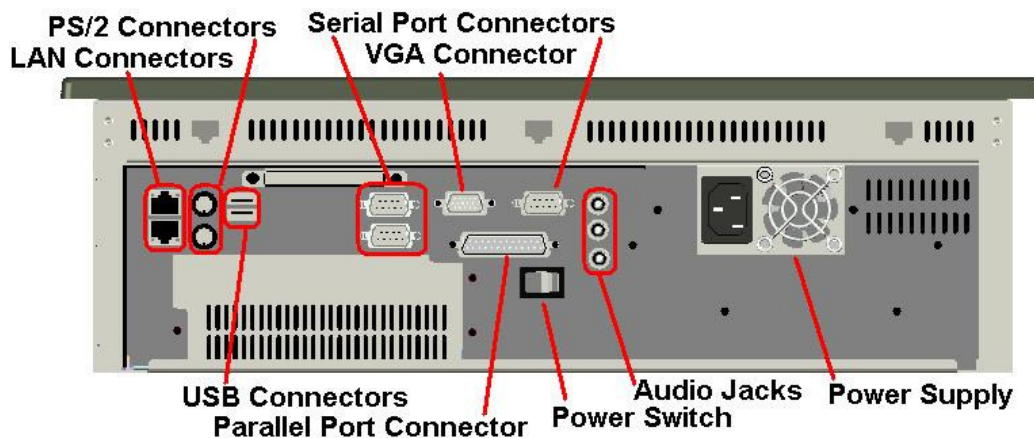

Figure 1-1. I/O Panel

Back Panel

The diagram below shows the back panel of the 4117T. For maintenance, installation or upgrade, first remove the back cover by unfastening 13 screws as shown in the diagram below.

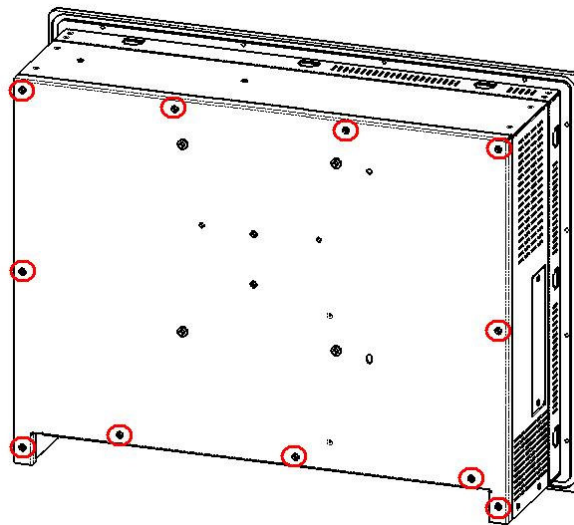

Figure 1-2. System Back Panel

Caution

Before any installation or un-installation, please take precautions to prevent damage to the components due to static electricity.

Front and Side Panels

One CD R/W- DVD is accessible from the side of the chassis.

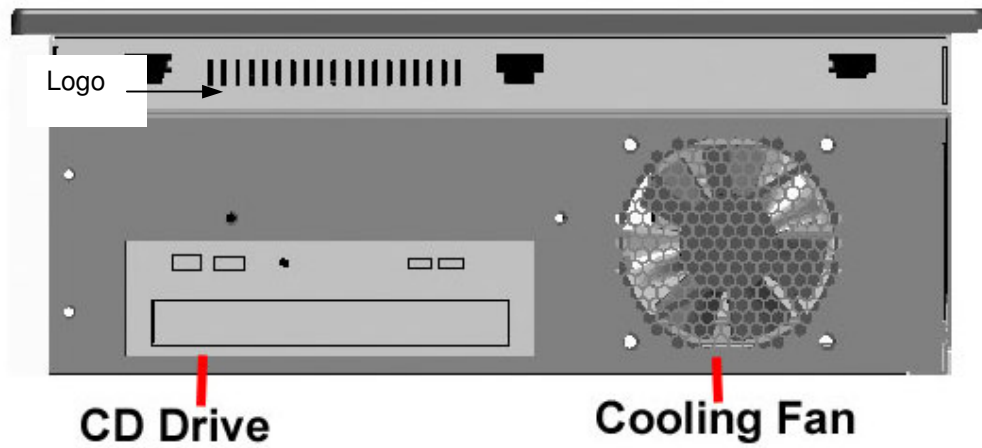

Figure 1-3. Right Side View

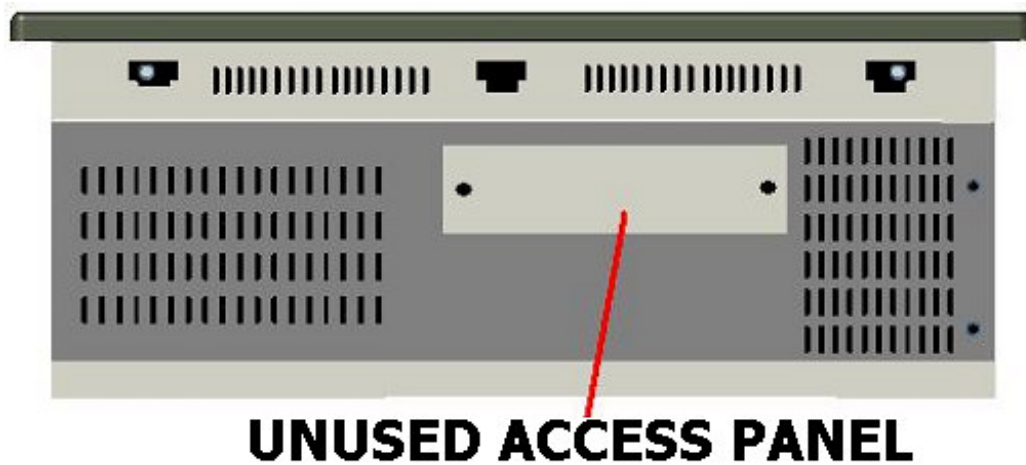

Figure 1-4. Left Side View

Unpacking the System

When you remove the system from its shipping container, verify that you have the parts listed below. Save the box and inner wrapping in the event you need to reship the unit.

- 4117T Unit
- Documentation kit, which includes:
 - Power cable
 - Twelve panel mounting clamps
 - Documentation and Support Library CD-ROM
 - Operating System Recovery Media or retail operating system (CD-ROM)

Quick Startup

This section gives you the steps to get the system up and running without explaining the capabilities and options.

Warning

Remove power from the unit and disconnect the power cord before making any adjustments to the inside or outside of the computer.

To prepare the system for use, perform the following steps.

1. Attach optional keyboard to the keyboard port, and optional mouse to the mouse port.
2. Confirm that the 100-240 VAC selector switch on the power supply is set appropriately.
3. Attach the power cord from the power receptacle to a properly grounded 100-240 VAC, 50-60 Hz outlet.
4. Turn on power to the unit (via an outlet power switch if applicable). The system will boot up into the operating system.
5. Install application software via the CD-ROM, or the network.

Chapter 2 — Installation

Installation Overview

The rugged design of the 4117T unit allows it to be installed in most industrial environments. The system is generally placed in a NEMA 4/4X/12 enclosure to protect against contaminants such as dust, and moisture. Metal enclosures also help minimize the effects of electromagnetic radiation that nearby equipment can generate.

Read the following sections carefully to be sure that you are complying with all the safety requirements.

1. Select a NEMA rated enclosure and place the unit to allow easy access to the system ports (see other sections in this chapter and Appendix A).
 - To assure a NEMA 4 seal choose an approved enclosure that has a 14-gauge (0.075 in/1.9 mm thick steel or 0.125 in/3.2 mm thick aluminum) front face.
 - Be sure to account for the unit's depth when choosing the depth of the enclosure.
2. Create a cutout in the enclosure (see *Figure 2-2*).
 - Be sure to place the unit at a comfortable working level
 - Make sure the area around the cutout is clean and free from metal burrs
3. Mount the unit in an upright position and properly secure the unit into the panel.
 - Tighten the twelve panel mounting clamps to 25 inch-pounds (2.8 Newton-meters / 28Kgf cm).
4. Attach one end of the power cord to the power receptacle on the unit and the other end to a properly grounded 100-240 VAC, 50-60 Hz outlet.
5. Turn on power to the system. The system will boot up the installed operating system.
6. Install the application software via a CD-ROM, or the network.

Additional aspects to take into account when mounting your 4117T unit:

- Consider locations of accessories such as AC power outlets and lighting (interior lighting and windows) for installation and maintenance convenience
- Prevent condensation by installing a thermostat-controlled heater or air conditioner
- To allow for maximum cooling, avoid obstructing the airflow

- Place any fans or blowers close to the heat generating devices. If using a fan, make sure that outside air is not brought into the enclosure unless a fabric or other reliable filter is used. This filtration prevents conductive particles and other harmful contaminants from entering the enclosure.
- Do not select a location near equipment that generates excessive electromagnetic interference (EMI) or radio frequency interference (RFI). Examples of these types of equipment are: high power welding machines; induction heating equipment; and large motor starters.
- Place incoming power line devices (such as isolation or constant voltage transformers, local power disconnects, and surge suppressers) away from the system. The proper location of incoming line devices keeps power wire runs as short as possible and minimizes electrical noise transmitted to the unit.
- Make sure the location does not exceed the unit's shock, vibration, and temperature specifications
- Install the unit in the rack or panel in such a way as to ensure that it does not cause a hazard from uneven mechanical loading
- Incorporate a readily-accessible disconnect device in the fixed wiring on permanently connected equipment
- Avoid circuit overloading of the supply circuit

Mechanical Dimensions

Front Panel: 17.79" (451.61 mm) x 13.99"(355.25 mm) x 0.39"(9.79 mm) (WxHxD)

Cabinet: 15.1" (399.98 mm) x 12.91" (328 mm) x 4.94" (125.41 mm) (WxHxD)

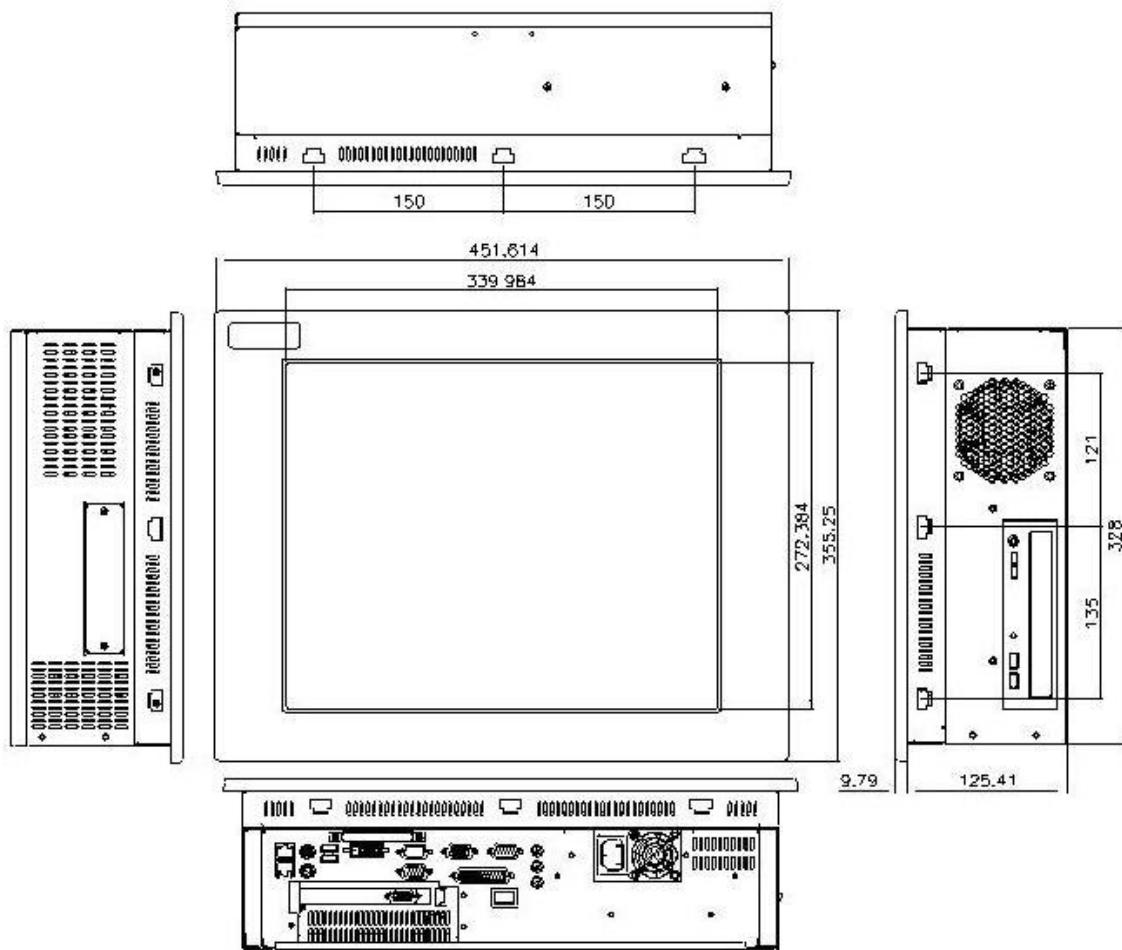

Note: All dimensions in mm)

Figure 2-1. Unit Dimensions

Mounting Options

The 4117T can be mounted to a panel, to the wall, or to an arm. The following sections describe each mounting option for the 4117T.

Panel Mounting

The 4117T is designed for panel mounting. Before mounting the 4117T to the panel, check the cut out dimensions as shown in Figure 2-2. Then, mount it to the panel using twelve supporters, as shown in the Figure 2-3 and Figure 2-4 (see next page).

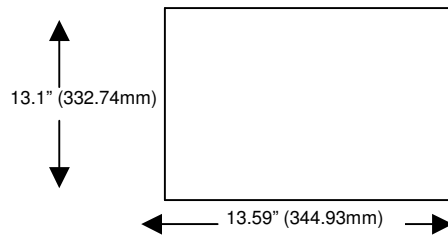

Figure 2-2. Panel Cutout Dimensions

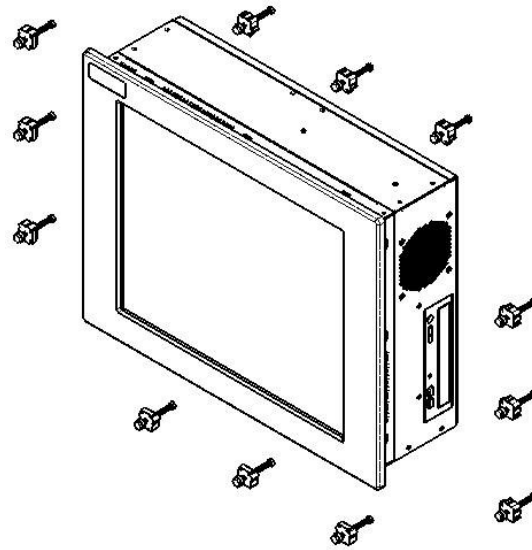

Figure 2-3. Panel Mounting Diagram

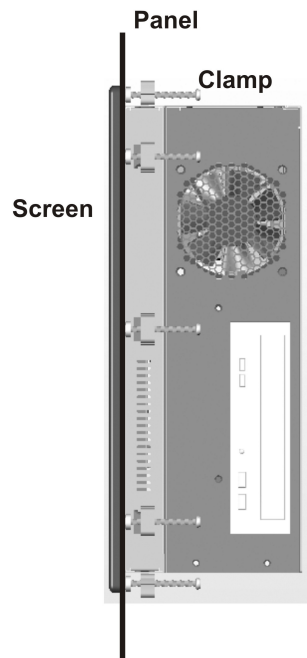

Figure 2-4 Panel Mounting Diagram

Wall Mounting

The 4117T is suitable for wall mount using the included brackets and hardware. See Figure 2-5 for wall mounting bracket. See Figure 2-7, Figure 2-8 and Figure 2-9 for wall-mounting diagrams

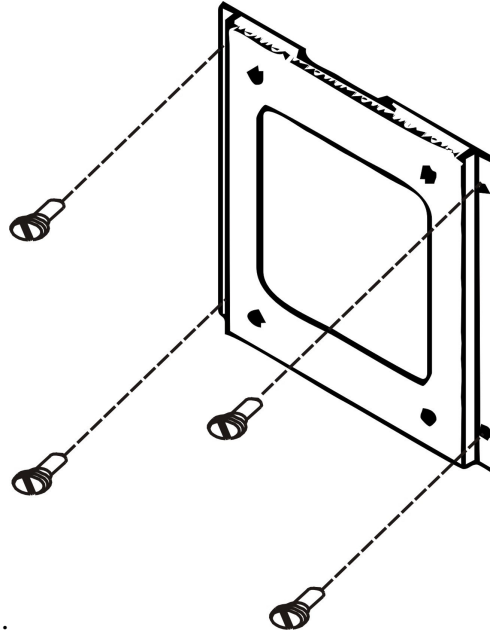

Figure 2-5. Wall Mounting Bracket

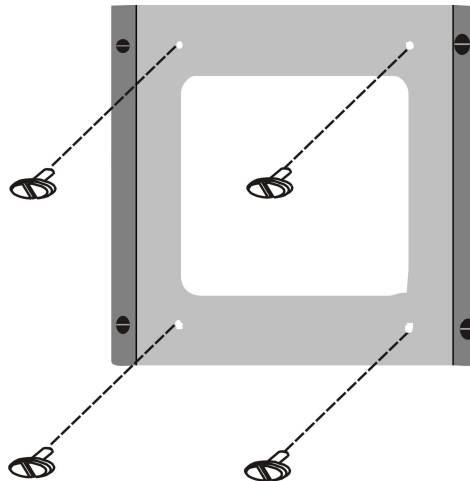

Figure 2-6. Chassis Support Screws

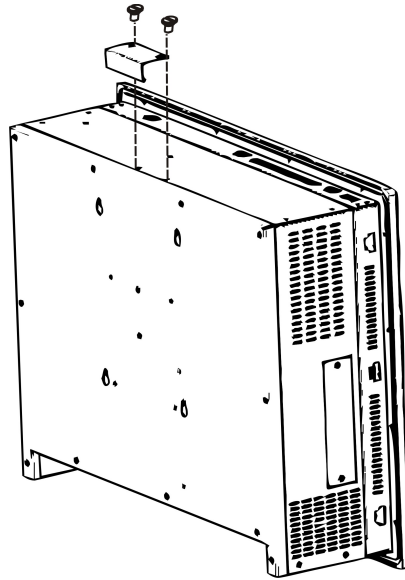

Figure 2-7. Wall Mounting Diagram – Install wall-mounting hook

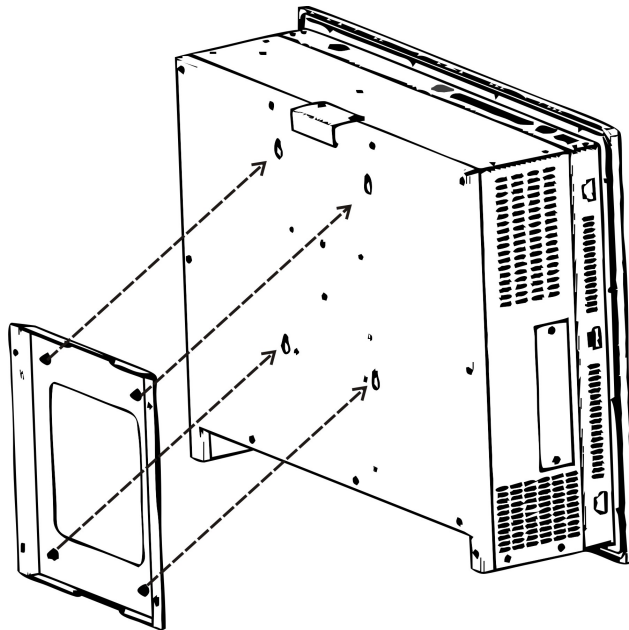
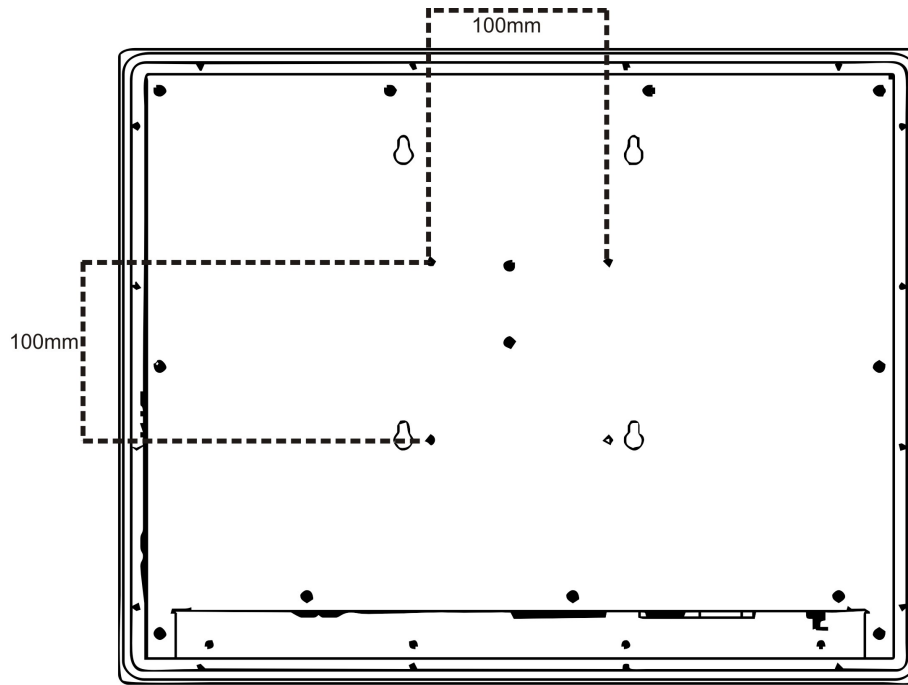

Figure 2-8. Wall Mounting Diagram – Mount the bracket

Arm Mounting

The 4117T also accommodates 75/100 mm interface pads for arm mounting. Figure 2-9 gives the dimensions for arm mounting.



All dimensions in mm

Figure 2-9. Arm Mounting Dimensions

Chapter 3 – ICPMB-7570 Motherboard

ICPMB-7570 CPU Board

Product Overview

The 4117T is equipped with a ICPMB-7570 Socket 479 Pentium M with CPU control board. It is equipped with a high-performance processor and advanced high performance multi-mode I/O.

Specifications

The following section lists some of the features of the 855GME and the ICH4 chipsets. For more information on these two chipsets please refer to the Intel website.

- 400 MHz system bus delivers a high-bandwidth connection between the processor and the platform
- Integrated graphics utilizing Intel® Extreme Graphics 2 technology
- AGP 4X support
- Three USB host controllers provide high-performance peripherals with 480 Mbps of bandwidth, while enabling support for up to six USB 2.0 ports (only two available on the I/O panel).
- The latest AC '97 implementation delivers 20-bit audio for enhanced sound quality and full surround sound capability
- LAN Connect Interface (LCI) provides flexible network solutions such as 10/100 Mbps Ethernet and 10/100 Mbps Ethernet with LAN manageability
- Dual Ultra ATA/100 controllers, coupled with the Intel® Application Accelerator support faster IDE transfers to storage devices
- PCI Local Bus Specification, Revision 2.2-compliant with support for 33 MHz PCI operations.
- ACPI Power Management Logic Support
- Enhanced DMA controller, Interrupt controller, and timer functions
- Supports Audio Codec '97, Revision 2.3 specification
- Alert On LAN* (AOL) and Alert On LAN 2* (AOL2)

Graphics Support

The graphics features listed below are all integrated on the 855GME chipset.

Display

- Analog display support
- Dual independent pipe support
 - Concurrent: different images and native display timings on each display device
 - Simultaneous: same images and native display timings on each display device
- DVO (DVOB and DVOC) support
 - Digital video out ports DVOB and DVOC with 165 MHz dot clock on each 12-bit interface; two 12-bit channels can be combined to form one dual-channel 24-bit interface with an effective dot clock of 330 MHz
 - Compliant with DVI Specification 1.0
- Dedicated Local Flat Panel (LFP) LVDS interface

Internal Graphics Features

- Core frequency
 - Display core frequency of 133 MHz
 - Render core frequency of 133 MHz

Intel® Embedded Graphics Drivers

- Graphics interface support
 - GDI and DirectX* DirectDraw* with overlay for Windows* XP, Windows* 2000, and Windows* Embedded XP
 - XFree86*, XAA, and Xv for Linux*
- Multi-monitor support
 - Multiple programmable configurations
 - Dual independent display
 - DVO device support/TV-Out
- Dynamic display-mode support
 - User definable and extensible
- Embedded video BIOS
 - Common port interface support
 - Full VGA compatibility

ICPMB-7570E CPU Board Layout

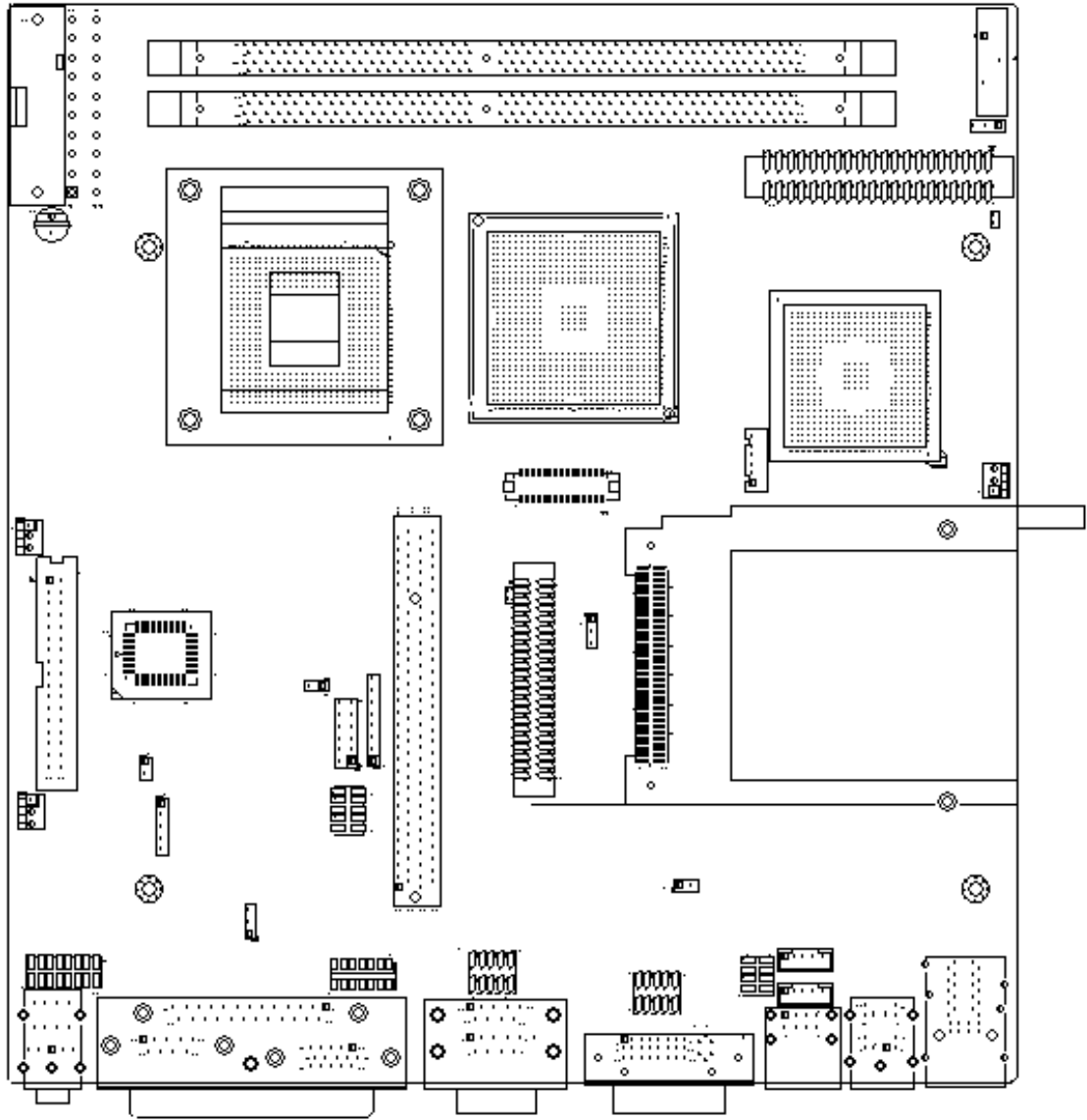

Figure 3-1. ICPMB-7570E Board Layout

Caution

Some components on ICPMB-7570E are very sensitive to static discharges. To protect it from unintended damage, be sure to follow these precautions:

1. Ground yourself to remove any static charge before touching your ICPMB-7570E. You can do it by using a grounded wrist strap at all times or by frequently touching any conducting materials that is connected to the ground.
2. Handle your ICPMB-7570E by its edges. Don't touch IC chips, leads or circuitry if not necessary.
3. Do not plug any connector or jumper while the power is on.
4. Do not put your ICPMB-7570E unprotected on a flat surface, as the board has components on both sides.

Jumper Settings

The following table lists the functions of all the jumpers on the 4117T. The following sections describe how to set jumpers on the ICPMB-7570 board.

Table 3-1. Jumper Functions

| Label | Function |
|-------|------------------------------------|
| JP2 | CMOS State Setting |
| JP4 | CF Card Setting |
| JP5 | LCD Voltage Setting |
| JP6 | COM3 Mode RS-232 or RS-485 Setting |

JP2: Clear CMOS Setup

If the CPU Card fails to boot due to improper BIOS settings, use this jumper to clear the CMOS data and reset the system BIOS information. To do this, use the jumper cap to close pins 2 and 3 for a few seconds then reinstall the jumper clip back to pins 1 and 2.

If the “CMOS Settings Wrong” message displays during the boot up process, you may then try to correct the fault by pressing the F1 to enter the CMOS Setup menu. You may then do one of the following:

- Enter the correct CMOS setting
- Load Optimal Defaults
- Load Failsafe Defaults.

After you have done one of the above, save your changes and exit the CMOS Setup menu.

| JP2 | DESCRIPTION |
|-------|-------------|
| 1 - 2 | Normal |
| 2 - 3 | Clear CMOS |

JP4: CF card setup

This jumper setting allows you to configure a CF card as either the slave or the master.

| JP4 | DESCRIPTION |
|-------|----------------|
| Open | Slave(Default) |
| Close | Master |

JP5: LCD voltage setup



WARNING:

Do not change this voltage. This voltage has been preset and is compatible with the currently installed 17" TFT LCD screen. If you change this jumper setting you may cause damage to the system.

This jumper sets the voltage for the LCD screen. This setting **MUST NOT** be changed.

| JP5 | DESCRIPTION |
|-----|---------------|
| 1-2 | 3.3V(Default) |
| 2-3 | 5V |

JP6: RS-232/485 Setup(for COM3)

This jumper allows you to configure the COM3 serial port as a RS-485 compatible serial communications port (must also connect an interface cable from a 4117T I/O plate to the 14 pin COM3 header).

| JP6 | DESCRIPTION |
|-----|-----------------|
| 1-2 | RS-232(Default) |
| 2-3 | RS-485 |

Connector Pin Outs

The following describes how to connect peripherals, switches and indicators to ICPMB-7570 board.

Peripheral Interface Connectors

The 4117T flat panel PC motherboard, the ICPMB-7570 comes with a number of peripheral interface connectors and configuration jumpers listed in Chapter 3. The pinouts for these connectors are listed below:

CN5: Front Panel Connector

| PIN NO. | DESCRIPTION | PIN NO. | DESCRIPTION |
|---------|-------------|---------|-------------|
| 1 | | 2 | |
| 3 | | 4 | |
| 5 | | 6 | |
| 7 | GND | 8 | LCD Rotate |

CN9: DISC LED

| PIN NO. | DESCRIPTION |
|---------|-------------|
| 1 | +LED |
| 2 | -LED |

CN12 : System Panel Connectors

| PIN NO. | DESCRIPTION | PIN NO. | DESCRIPTION |
|---------|-------------|---------|-------------|
| 1-3 | POWER LED | 2-8 | SPEAKER |
| 5-7 | PWR BUTTON | 10-12 | RESET |
| 9-11 | HDLED | | |

IDE1: Primary IDE Interface Connector

| PIN NO. | DESCRIPTION | PIN NO. | DESCRIPTION |
|---------|-------------|---------|-------------|
| 1 | RESET# | 2 | GROUND |
| 3 | DATA 7 | 4 | DATA 8 |
| 5 | DATA 6 | 6 | DATA 9 |

| | | | |
|----|-------------|----|--------------------|
| 7 | DATA 5 | 8 | DATA 10 |
| 9 | DATA 4 | 10 | DATA 11 |
| 11 | DATA 3 | 12 | DATA 12 |
| 13 | DATA 2 | 14 | DATA 13 |
| 15 | DATA 1 | 16 | DATA 14 |
| 17 | DATA 0 | 18 | DATA 15 |
| 19 | GROUND | 20 | N/C |
| 21 | IDE DRQ | 22 | GROUND |
| 23 | IOW# | 24 | GROUND |
| 25 | IOR# | 26 | GROUND |
| 27 | IDE CHRDY | 28 | GROUND |
| 29 | IDE DACK | 30 | GROUND- DEFAULT |
| 31 | INTERRUPT | 32 | N/C |
| 33 | SA1 | 34 | N/C |
| 35 | SA0 | 36 | SA2 |
| 37 | HDC CS0# | 38 | HDC CS1# |
| 39 | HDD ACTIVE# | 40 | GROUND |

IDE2: Secondary IDE Interface Connector

| PIN NO. | DESCRIPTION | PIN NO. | DESCRIPTION |
|---------|-------------|---------|-------------|
| 1 | RESET# | 2 | GROUND |
| 3 | DATA 7 | 4 | DATA 8 |
| 5 | DATA 6 | 6 | DATA 9 |
| 7 | DATA 5 | 8 | DATA 10 |
| 9 | DATA 4 | 10 | DATA 11 |
| 11 | DATA 3 | 12 | DATA 12 |
| 13 | DATA 2 | 14 | DATA 13 |

| | | | |
|----|-------------|----|--------------------|
| 15 | DATA 1 | 16 | DATA 14 |
| 17 | DATA 0 | 18 | DATA 15 |
| 19 | GROUND | 20 | N/C |
| 21 | IDE DRQ | 22 | GROUND |
| 23 | IOW# | 24 | GROUND |
| 25 | IOR# | 26 | GROUND |
| 27 | IDE CHRDY | 28 | GROUND |
| 29 | IDE DACK | 30 | GROUND- DEFAULT |
| 31 | INTERRUPT | 32 | N/C |
| 33 | SA1 | 34 | N/C |
| 35 | SA0 | 36 | SA2 |
| 37 | HDC CS0# | 38 | HDC CS1# |
| 39 | HDD ACTIVE# | 40 | GROUND |
| 41 | VCC | 42 | VCC |
| 43 | GROUND | 44 | N/C |

CN7: Compact Flash Connector

| PIN NO. | DESCRIPTION | PIN NO. | DESCRIPTION |
|---------|-------------|---------|---------------|
| 1 | GROUND | 26 | VCC-IN CHECK1 |
| 2 | DATA 3 | 27 | DATA 11 |
| 3 | DATA 4 | 28 | DATA 12 |
| 4 | DATA 5 | 29 | DATA 13 |
| 5 | DATA 6 | 30 | DATA 14 |
| 6 | DATA 7 | 31 | DATA 15 |
| 7 | HDC_CS0# | 32 | HDC_CS1 |
| 8 | N/C | 33 | N/C |
| 9 | GROUND | 34 | IOR# |
| 10 | N/C | 35 | IOW# |
| 11 | N/C | 36 | VCC_COM |
| 12 | N/C | 37 | IRQ15 |
| 13 | VCC_COM | 38 | VCC_COM |

| | | | |
|----|---------------|----|-------------|
| 14 | N/C | 39 | CSEL |
| 15 | N/C | 40 | N/C |
| 16 | N/C | 41 | HDD_RESET |
| 17 | N/C | 42 | IORDY |
| 18 | SA2 | 43 | SDREQ |
| 19 | SA1 | 44 | SDACK# |
| 20 | SA0 | 45 | HDD_ACTIVE# |
| 21 | DATA 0 | 46 | 66DET |
| 22 | DATA 1 | 47 | DATA 8 |
| 23 | DATA 2 | 48 | DATA 9 |
| 24 | N/C | 49 | DATA 10 |
| 25 | VCC-IN CHECK2 | 50 | GROUND |

FDD1 :FLOPPY CONNECTOR

| PIN NO. | DESCRIPTION | PIN NO. | DESCRIPTION |
|---------|-------------|---------|-------------|
| 1 | GND | 2 | DENSEL |
| 3 | GND | 4 | NC |
| 5 | NC | 6 | NC |
| 7 | GND | 8 | INDEX |
| 9 | GND | 10 | MTRA |
| 11 | GND | 12 | DRVB |
| 13 | GND | 14 | DRVA |
| 15 | GND | 16 | MTRB |
| 17 | GND | 18 | DIR |
| 19 | GND | 20 | STEP |
| 21 | GND | 22 | WDATA |
| 23 | GND | 24 | WGATE |
| 25 | GND | 26 | TRK0 |
| 27 | GND | 28 | WPT |
| 29 | GND | 30 | RDATA |
| 31 | GND | 32 | SIDE1 |
| 33 | GND | 34 | DSKCHG |

CN1.A : Parallel Port Connector

| PIN NO. | DESCRIPTION | PIN NO. | DESCRIPTION |
|---------|--------------------|---------|------------------|
| 1 | STROBE# | 2 | DATA 0 |
| 3 | DATA 1 | 4 | DATA 2 |
| 5 | DATA 3 | 6 | DATA 4 |
| 7 | DATA 5 | 8 | DATA 6 |
| 9 | DATA 7 | 10 | ACKNOWLEDGE |
| 11 | BUSY | 12 | PAPER EMPTY |
| 13 | PRINTER SELECT | 14 | AUTO FORM FEED # |
| 15 | ERROR# | 16 | INITIALIZE |
| 17 | PRINTER SELECT LN# | 18 | GROUND |
| 19 | GROUND | 20 | GROUND |
| 21 | GROUND | 22 | GROUND |
| 23 | GROUND | 24 | N/C |
| 25 | GROUND | 26 | |

CN1.B : COM1 Connector(RS-232)

| PIN NO. | DESCRIPTION | PIN NO. | DESCRIPTION |
|---------|-------------|---------|-------------|
| 1 | DCD1 | 2 | DSR1 |
| 3 | RX1 | 4 | RTS1 |
| 5 | TX1 | 6 | CTS1 |
| 7 | DTR1 | 8 | RI1 |
| 9 | GND | 10 | GND |

CN1.C : CRT(15-pin Female Connector)

| PIN NO. | DESCRIPTION | PIN NO. | DESCRIPTION |
|---------|-------------|---------|-------------|
| 1 | RED | 9 | NC |
| 2 | GREEN | 10 | GROUND |
| 3 | BLUE | 11 | NC |
| 4 | NC | 12 | DDCDAT |
| 5 | GROUND | 13 | HSYNC |
| 6 | GROUND | 14 | VSYNC |
| 7 | GROUND | 15 | DDCCLK |
| 8 | GROUND | | |

J5 (Dual DB-9 CONNECTOR): COM2,COM3(RS-232)

| PIN NO. | DESCRIPTION | PIN NO. | DESCRIPTION |
|---------|-------------|---------|-------------|
| 1 | DCD2/3 | 2 | DSR2/3 |
| 3 | RX2/3 | 4 | RTS2/3 |
| 5 | TX2/3 | 6 | CTS2/3 |
| 7 | DTR2/3 | 8 | RI2/3 |
| 9 | GND | 10 | GND |

COM3 : COM3(RS-232/485) (14-pin Pin Header, Shared with J5.Com3)

| PIN NO. | DESCRIPTION | PIN NO. | DESCRIPTION |
|---------|-------------|---------|-------------|
| 1 | DCD3 | 2 | DSR3 |
| 3 | RX3 | 4 | RTS3 |
| 5 | TX3 | 6 | CTS3 |
| 7 | DTR3 | 8 | RI3 |
| 9 | GND | 10 | GND |
| 11 | TX3+ | 12 | TX3- |
| 13 | RX3+ | 14 | RX3- |

COM4 : COM4(10-pin Pin Header, Shared with J5.Com3)

| PIN NO. | DESCRIPTION | PIN NO. | DESCRIPTION |
|---------|-------------|---------|-------------|
| 1 | DCD4 | 2 | DSR4 |
| 3 | RX4 | 4 | RTS4 |
| 5 | TX4 | 6 | CTS4 |
| 7 | DTR4 | 8 | RI4 |
| 9 | GND | 10 | GND |

KB_MS1 : PS/2 Keyboard & Mouse Connector

| PIN NO. | DESCRIPTION | PIN NO. | DESCRIPTION |
|---------|-------------|---------|-------------|
| 1 | KB DATA | 7 | MS DATA |
| 2 | NC | 8 | NC |
| 3 | GND | 9 | GND |
| 4 | 5V | 10 | 5V |
| 5 | KB CLK | 11 | MS CLK |
| 6 | NC | 12 | NC |

USB1: USB(0~1) Connector

| PIN NO. | DESCRIPTION | PIN NO. | DESCRIPTION |
|---------|-------------|---------|-------------|
| 1 | USBVCC0 | 2 | USBVCC1 |
| 3 | D0- | 4 | D1- |
| 5 | D0+ | 6 | D1+ |
| 7 | USBGND0 | 8 | USBGND1 |

USB2: USB(2~3) Connector(2*4 Pin header)

| PIN NO. | DESCRIPTION | PIN NO. | DESCRIPTION |
|---------|-------------|---------|-------------|
| 1 | USBVCC2 | 2 | USBGND3 |
| 3 | D2- | 4 | D3+ |
| 5 | D2+ | 6 | D3- |
| 7 | USBGND2 | 8 | USBVCC3 |

USB3,USB4: USB(4~5) Connector(1*5 Pin header)

| PIN NO. | DESCRIPTION | PIN NO. | DESCRIPTION |
|---------|-------------|---------|-------------|
| 1 | GND | 2 | USBVCC4 |
| 3 | GND | 4 | D4+ |
| 5 | D4- | | |

LAN1: DUAL RJ45 Connector

| PIN NO. | Description | PIN NO. | Description |
|---------|-------------|---------|-------------|
| A1 | MDIOA0+ | B1 | MDIOB0+ |
| A2 | MDIOA0- | B2 | MDIOB0- |
| A3 | MDIOA1+ | B3 | MDIOB1+- |
| A4 | MDIOA1- | B4 | MDIOB1- |
| A5 | MDIOA2+ | B5 | NC |
| A6 | MDIOA2- | B6 | NC |
| A7 | MDIOA3+ | B7 | NC- |
| A8 | MDIOA3- | B8 | NC |
| A9 | NC | B9 | NC |
| A10 | NC | B10 | NC |
| A11 | LINK1000 | B11 | VCC |
| A12 | LINK100 | B12 | LINK100 |
| A13 | ACT | B13 | ACT |
| A14 | LINK | B14 | LINK |
| A15-17 | GND | B15-17 | GND |

CN8: LCD LVDS Interface Connector

| PIN NO. | Description | PIN NO. | Description |
|---------|-------------|---------|-------------|
| 1 | GND | 2 | GND |
| 3 | LVDS_Y3+ | 4 | LVDS_Y3- |
| 5 | LVDS_CLK+ | 6 | LVDS_CLK- |
| 7 | LVDS_Y2+ | 8 | LVDS_Y2- |
| 9 | LVDS_Y1+ | 10 | LVDS_Y1- |
| 11 | LVDS_Y0+ | 12 | LVDS_Y0- |
| 13 | GND | 14 | GND |
| 15 | LVDSB_Y3+ | 16 | LVDSB_Y3- |
| 17 | LVDSBCLK+ | 18 | LVDSBCLK- |
| 19 | LVDSB_Y2+ | 20 | LVDSB_Y2- |
| 21 | LVDSB_Y1+ | 22 | LVDSB_Y1- |
| 23 | LVDSB_Y0+ | 24 | LVDSB_Y0- |
| 25 | GND | 26 | GND |
| 27 | VCC_LCD | 28 | VCC_LCD |
| 29 | VCC_LCD | 30 | VCC_LCD |

CN3: Inverter Power Connector

| PIN NO. | DESCRIPTION | PIN NO. | DESCRIPTION |
|---------|-------------|---------|-------------|
| 1 | VCC12 | 2 | VCC12 |
| 3 | BKLT_EN | 4 | BKLT_ADJ |
| 5 | GND | 6 | GND |

PW1: ATX Power Connector

| PIN NO. | DESCRIPTION | PIN NO. | DESCRIPTION |
|---------|-------------|---------|-------------|
| 1 | 3.3V | 11 | 3.3V |
| 2 | 3.3V | 12 | -12V |
| 3 | GND | 13 | GND |
| 4 | 5V | 14 | PSON |
| 5 | GND | 15 | GND |
| 6 | 5V | 16 | GND |
| 7 | GND | 17 | GND |
| 8 | PWR OK | 18 | -5V |
| 9 | 5VSB | 19 | 5V |
| 10 | 12V | 20 | 5V |

DIO1: 8 Bits GPIO Connector

| PIN NO. | DESCRIPTION | PIN NO. | DESCRIPTION |
|---------|-------------|---------|-------------|
| 1 | GND | 2 | VCC5 |
| 3 | GPIO0 | 4 | GPIO1 |
| 5 | GPIO2 | 6 | GPIO3 |
| 7 | GPIO4 | 8 | GPIO5 |
| 9 | GPIO6 | 10 | GPIO7 |

CPU_FAN1, SYS_FAN1, SYS_FAN2: Fan Connector

| PIN NO. | DESCRIPTION |
|---------|------------------|
| 1 | Fan Speed Detect |
| 2 | +12V |
| 3 | GND |

CN11: Audio Connector (Shared With AUDIO1)

| PIN NO. | DESCRIPTION | PIN NO. | DESCRIPTION |
|---------|---------------|---------|-------------|
| 1 | Speaker out R | 2 | GND |
| 3 | Speaker out L | 4 | GND |
| 5 | Line out R | 6 | Line out L |
| 7 | GND | 8 | GND |
| 9 | Line in R | 10 | Line in L |
| 11 | GND | 12 | GND |
| 13 | NC | 14 | NC |
| 15 | MIC1/CEN OUT | 16 | LFE OUT |

IR1: IR Interface

| PIN NO. | DESCRIPTION | PIN NO. | DESCRIPTION |
|---------|-------------|---------|-------------|
| 1 | VCC5 | 2 | NC |
| 3 | IRRX | 4 | GND |
| 5 | IRTX | 6 | |

AMI BIOS Setup

This section describes the AMI Setup program built into the ROM BIOS. The setup program allows users to modify the basic system configuration. This special information is then stored in battery-backed RAM so that it retains the Setup information when the power is turned off.

Warning

For Advanced Users Only – Changing settings in the BIOS to values other than the defaults may cause the computer to stop functioning correctly.

Starting Setup

The AMI BIOS is immediately activated when you first power on the computer. The BIOS reads the system information contained in the CMOS and begins the process of checking out the system and configuring it. When it finishes, the BIOS will seek an operating system on one of the disks and then launch and turn control over to the operating system.

While the BIOS is in control, the Setup program can be activated in one of two ways:

1. By pressing immediately after switching the system on, or
2. By pressing the key when the following message appears briefly at the bottom of the screen during the POST (Power On Self Test).

Press DEL to enter SETUP.

If the message disappears before you respond and you still wish to enter Setup, restart the system to try again by turning it OFF then ON or pressing the "RESET" button on the system case. You may also restart by simultaneously pressing <Ctrl>, <Alt>, and <Delete> keys. If you do not press the keys at the correct time and the system does not boot, an error message will be displayed and you will again be asked to...

PRESS F2 TO CONTINUE, DEL TO ENTER SETUP

Using Setup

In general, you use the arrow keys to highlight items, press Enter to select, use the PgUp and PgDn keys to change entries, press F1 for help and press Esc to quit. The following table provides more detail about how to navigate in the Setup program using the keyboard.

Setup submenu: Main

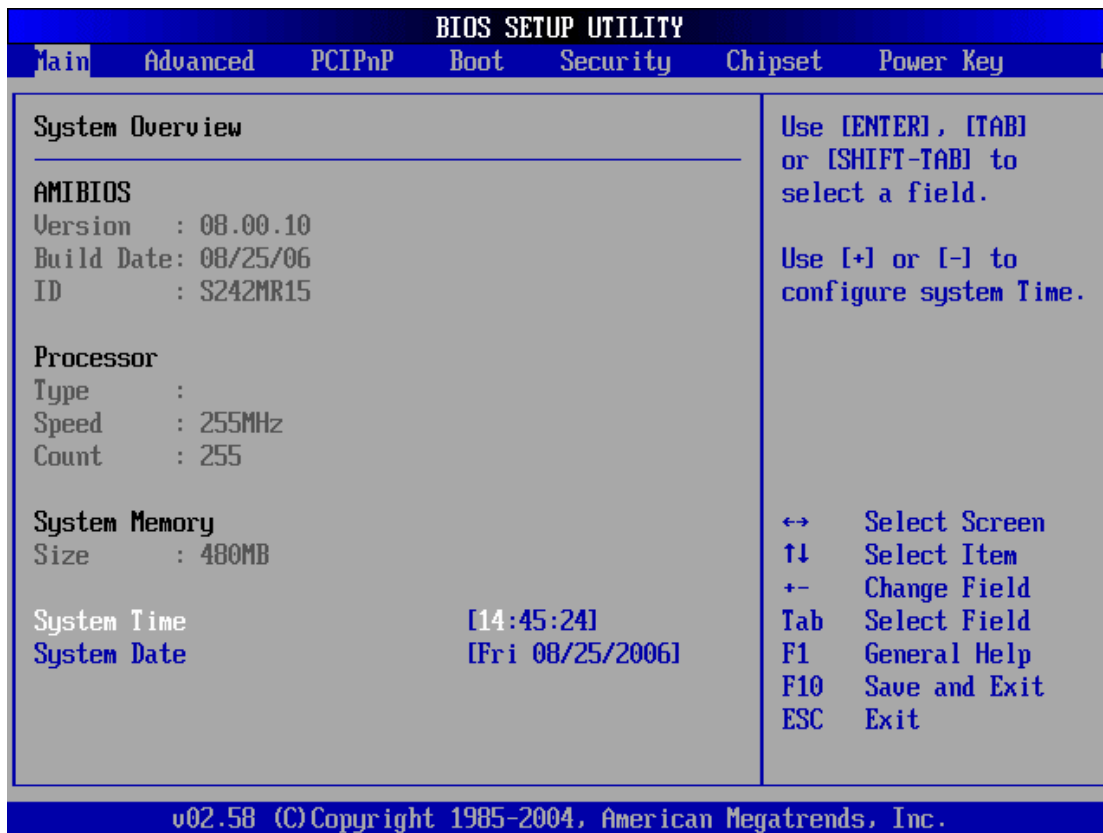

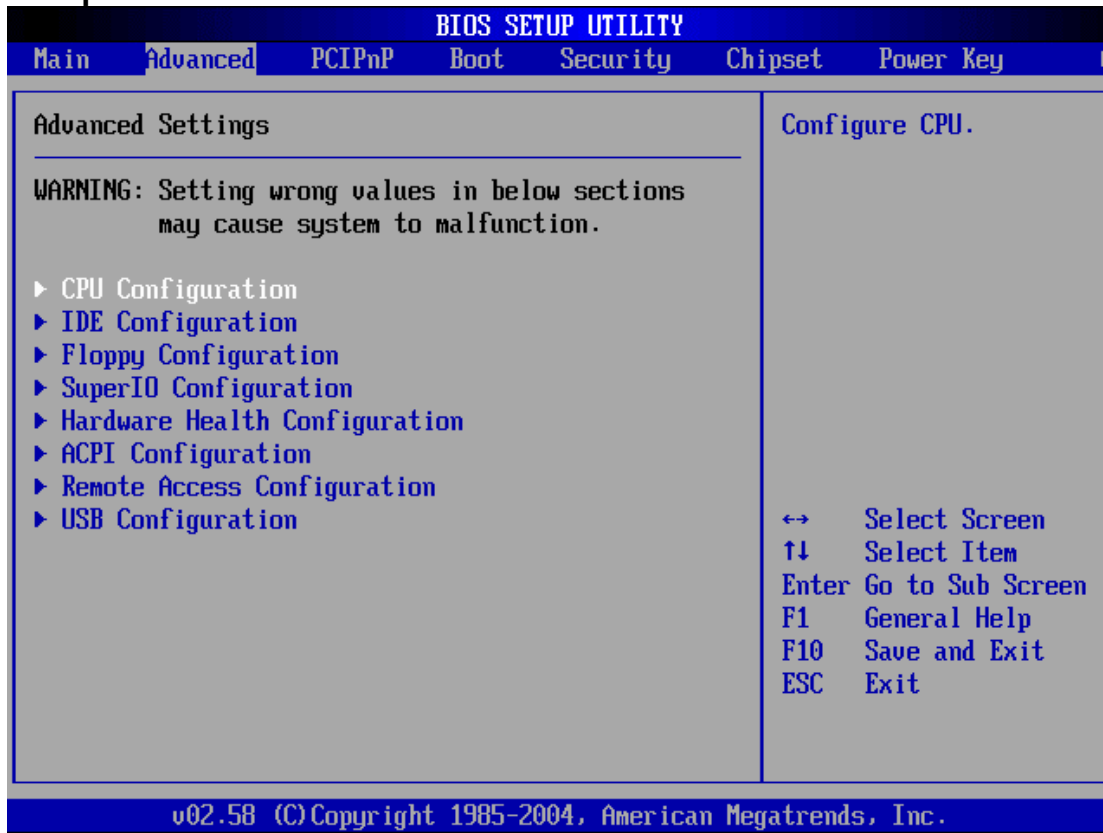
Setup submenu: Advanced

CPU Configuration



Options summary

| | | |
|-------------------------------------|---------------|-----------------------------------|
| CPU TM function | Disable | Optimal Default, Failsafe Default |
| | Enable | |
| Intel(R) SpeedStep(tm) tech. | Maximum Speed | Optimal Default |
| | Minimum Speed | |
| | Automatic | |
| | Disable | Failsafe Default |

IDE Configuration



Options summary

| | | |
|-----------------------------------|-----------|-----------------------------------|
| OnBoard PCI IDE Controller | Disable | Optimal Default, Failsafe Default |
| | Primary | |
| | Secondary | |
| | Both | |
| Hard Disk Write Protect | Disable | Optimal Default, Failsafe Default |
| | Enable | |

| | | |
|------------------------------------|---------------|-----------------------------------|
| IDE Detect Time Out (Sec) | 0 | Optimal Default, Failsafe Default |
| | 5 | |
| | 10 | |
| | 15 | |
| | 20 | |
| | 25 | |
| | 30 | |
| | 35 | |
| ATA(P) 80Pin Cable Dtection | Host & Device | Optimal Default, Failsafe Default |
| | Host | |
| | Device | |

Primary IDE Master

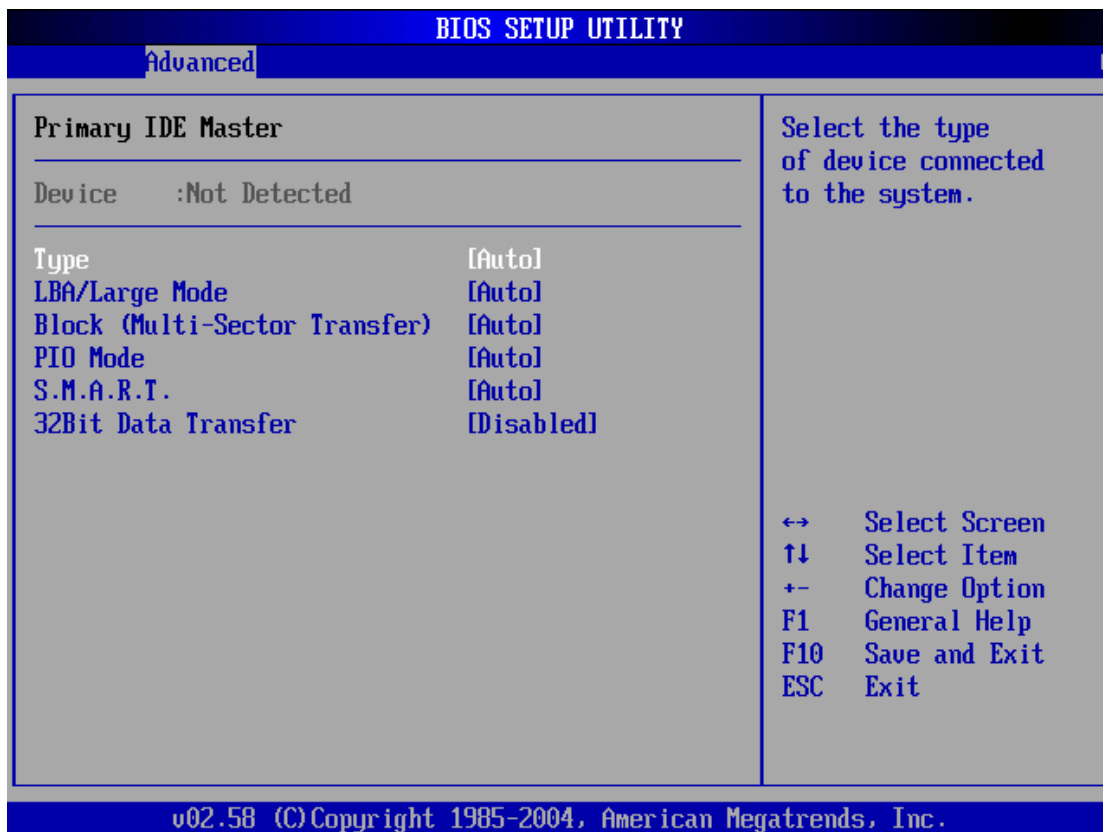

Options summary

| | | |
|---|-----------------|-----------------------------------|
| Type | Not Installed | Optimal Default, Failsafe Default |
| | <i>Auto</i> | |
| | <i>CDROM</i> | |
| | <i>ARMD</i> | |
| <p>Select the type corresponding to the device present.</p> <p>Not Installed : No device</p> <p>Auto : Auto detected</p> <p>CDROM: ATAPI CDROM</p> <p>ARMD : ATAPI Removable Media Device</p> | | |
| LBA/Large Mode | <i>Disabled</i> | Optimal Default, Failsafe Default |
| | <i>Auto</i> | |
| <p>Disabled: Disables LBA Mode.</p> <p>Auto: Enables LBA Mode if the device supports it and the device is not already formatted with LBA Mode disabled.</p> | | |
| Block (Multi-Sector Transfer) | <i>Disabled</i> | Optimal Default, Failsafe Default |
| | <i>Auto</i> | |
| <p>Disabled: The Data transfer from and to the device occurs one sector at a time.</p> <p>Auto: The Data transfer from and to the device occurs multiple sectors at a time if the device supports it.</p> | | |
| PIO Mode | <i>Auto</i> | Optimal Default, Failsafe Default |
| | <i>0</i> | |
| | <i>1</i> | |
| | <i>2</i> | |
| | <i>3</i> | |
| | <i>4</i> | |

| | | |
|--|-----------------|-----------------------------------|
| DMA Mode | <i>Auto</i> | Optimal Default, Failsafe Default |
| | <i>SWDMA0</i> | |
| | <i>SWDMA1</i> | |
| | <i>SWDMA2</i> | |
| | <i>MWDMA0</i> | |
| | <i>MWDMA1</i> | |
| | <i>MWDMA2</i> | |
| | <i>UDMA0</i> | |
| | <i>UDMA1</i> | |
| | <i>UDMA3</i> | |
| | <i>UDMA4</i> | |
| <p>Select DMA Mode.</p> <p>Auto : Auto detected</p> <p>SWDMA n: SingleWord DMA n</p> <p>MWDMA n: MultiWord DMA n</p> <p>UDMA n : Ultra DMA n</p> | | |
| S.M.A.R.T. | <i>Auto</i> | Optimal Default, Failsafe Default |
| | <i>Disabled</i> | |
| | <i>Enabled</i> | |
| S.M.A.R.T. stands for “Self-Monitoring, Analysis and Reporting Technology”. | | |
| 32Bit Data Transfer | <i>Disabled</i> | Optimal Default, Failsafe Default |
| | <i>Enabled</i> | |

Floppy Configuration

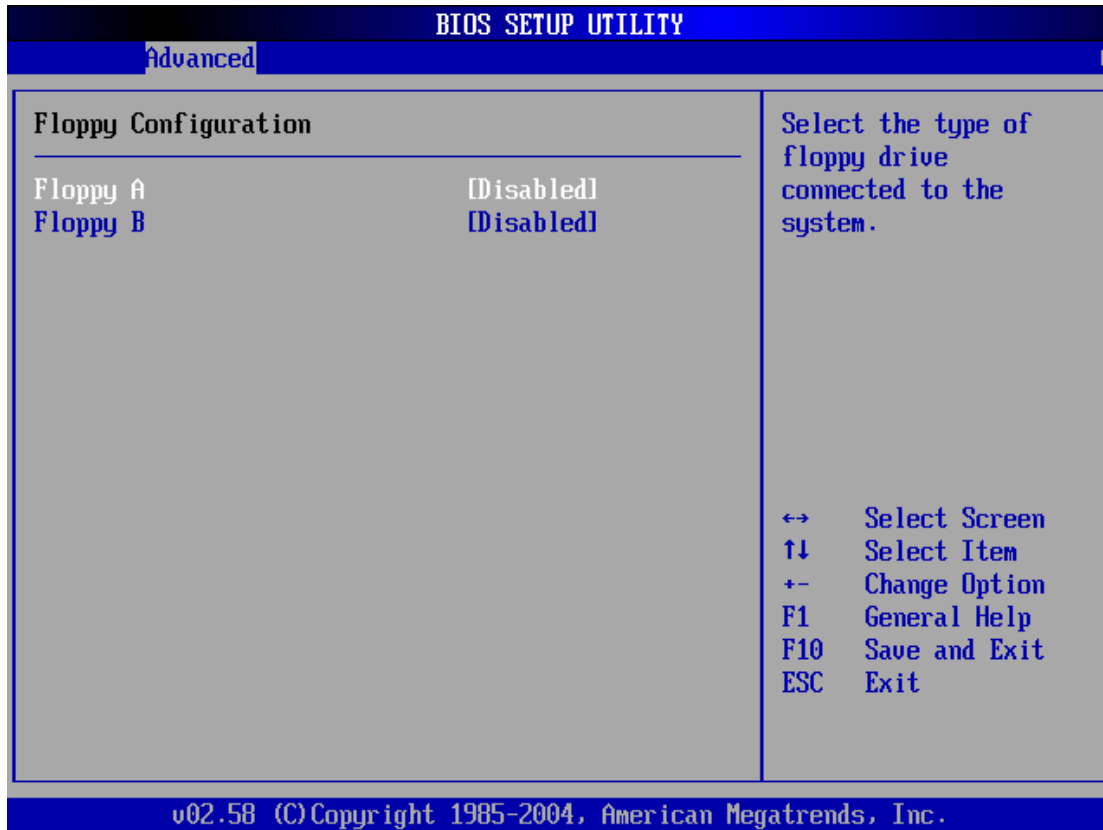

Options summary

| | | |
|--|---|-----------------------------------|
| Floppy A | Disabled | Optimal Default, Failsafe Default |
| | 360 KB 5 ¹ / ₄ " | |
| | 1.2 MB 5 ¹ / ₄ " | |
| | 720 KB 3 ¹ / ₂ " | |
| | 1.44 MB 3 ¹ / ₂ " | |
| | 2.88 MB 3 ¹ / ₂ " | |
| Select the floppy drive type. | | |
| ** Support only Floppy A, no Floppy B. | | |

Super I/O Configuration

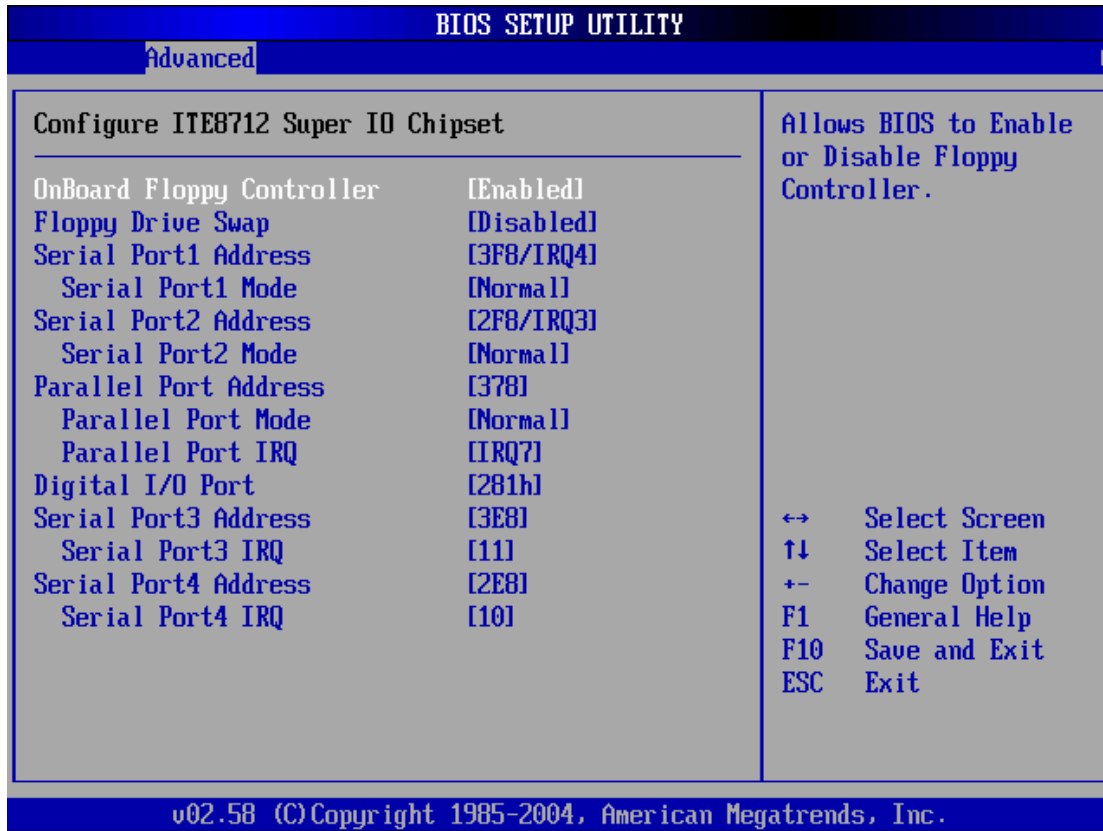

Options summary :

| | | |
|----------------------------------|-----------------|-----------------------------------|
| OnBoard Floppy Controller | <i>Enable</i> | Optimal Default, Failsafe Default |
| Floppy Driver Swap | <i>Disable</i> | Optimal Default, Failsafe Default |
| | <i>Enable</i> | **No Function |
| Serial Port1 Address | <i>3F8/IRQ4</i> | Optimal Default, Failsafe Default |
| | <i>3E8/IRQ4</i> | |
| | <i>2E8/IRQ3</i> | |
| Serial Port1 Mode | <i>Normal</i> | Optimal Default, Failsafe Default |
| | <i>IrDA</i> | |
| | <i>ASK IR</i> | |

| | | |
|------------------------------|-----------------|-----------------------------------|
| Serial Port2 Address | <i>2F8/IRQ3</i> | Optimal Default, Failsafe Default |
| | <i>3E8/IRQ4</i> | |
| | <i>2E8/IRQ3</i> | |
| Serial Port2 Mode | <i>Normal</i> | Optimal Default, Failsafe Default |
| | <i>IrDA</i> | |
| | <i>ASK IR</i> | |
| Parallel Port Address | <i>378</i> | Optimal Default, Failsafe Default |
| | <i>278</i> | |
| | <i>3BC</i> | |
| Parallel Port Mode | <i>Normal</i> | Optimal Default, Failsafe Default |
| | <i>EPP</i> | |
| | <i>ECP</i> | |
| | <i>EPP+ECP</i> | |
| Parallel Port IRQ | <i>IRQ5</i> | Optimal Default, Failsafe Default |
| | <i>IRQ7</i> | |
| Digital I/O port | <i>201h</i> | Optimal Default, Failsafe Default |
| | <i>221h</i> | |
| | <i>241h</i> | |
| | <i>261h</i> | |
| | <i>281h</i> | |
| Serial Port3 Address | <i>3E8</i> | Optimal Default, Failsafe Default |
| | <i>2E8</i> | |
| | <i>2F0</i> | |
| | <i>2E0</i> | |
| Serial Port3 IRQ | <i>3</i> | |
| | <i>4</i> | |
| | <i>10</i> | |

| | | |
|--|-----|-----------------------------------|
| | 11 | Optimal Default, Failsafe Default |
| Serial Port4 Address | 3E8 | Optimal Default, Failsafe Default |
| | 2E8 | |
| | 2F0 | |
| | 2E0 | |
| Serial Port5 IRQ | 3 | Optimal Default, Failsafe Default |
| | 4 | |
| | 10 | |
| | 11 | |
| Allows BIOS to Select Serial Port1 Base Addresses. | | |

H/W Health Configuration

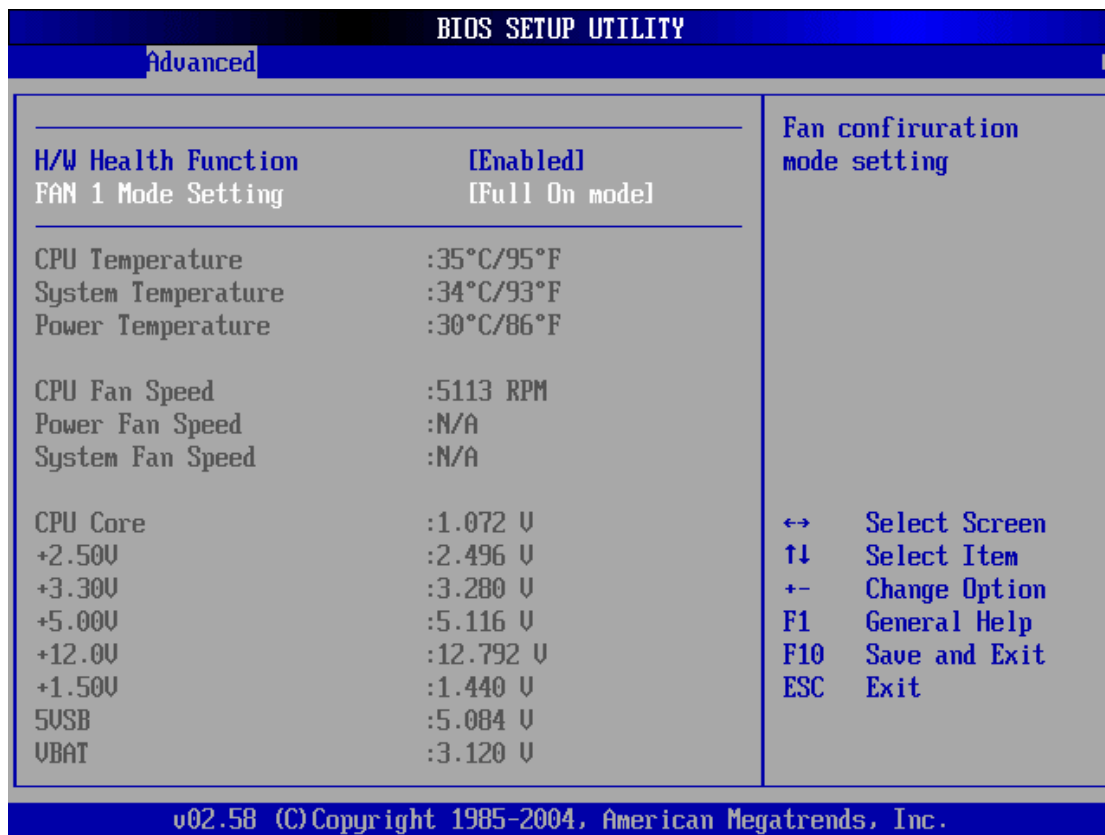

Options summary

| | | |
|----------------------------|--------------------------|-----------------------------------|
| H/W Health function | Disabled | Optimal Default, Failsafe Default |
| | <i>Enable</i> | |
| Fan 1 Mode Setting | <i>Full On Mode</i> | Optimal Default, Failsafe Default |
| | <i>Automatic mode</i> | |
| | <i>PWM Manually mode</i> | |

Remote Access Configuration



Options summary

| | | |
|----------------------|---------------|-----------------------------------|
| Remote Access | Disabled | Optimal Default, Failsafe Default |
| | <i>Enable</i> | |

USB Configuration

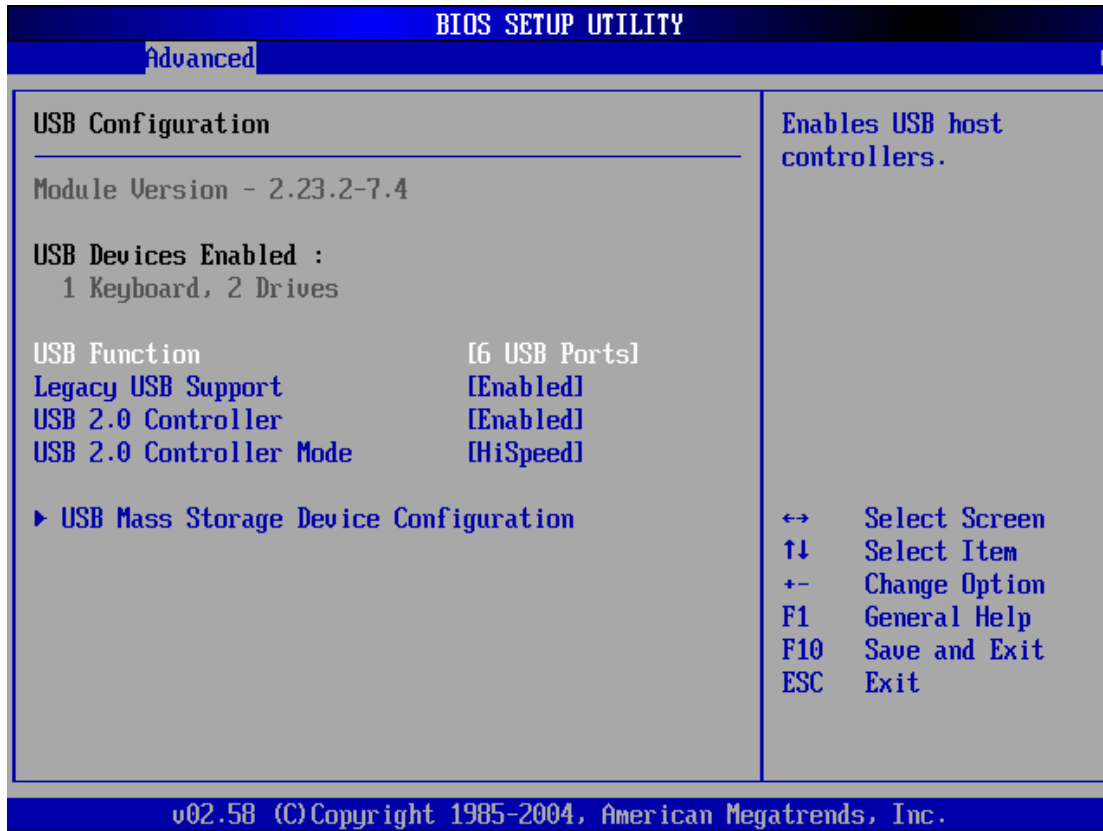

Options summary

| | | |
|--------------------------------|-------------|--|
| USB function | Disabled | Optimal Default, Failsafe Default |
| | 2 USB Ports | |
| | 4 USB Ports | |
| | 6 USB Ports | |
| Legacy USB Support | Disabled | Optimal Default, Failsafe Default |
| | Enable | |
| USB 2.0 Controller | Disable | Failsafe Default |
| | Enable | Optimal Default |
| USB 2.0 Controller Mode | FullSpeed | ** Only exist when enable USB 2.0 Controller |
| | HiSpeed | |

Advanced PCI/PnP Settings



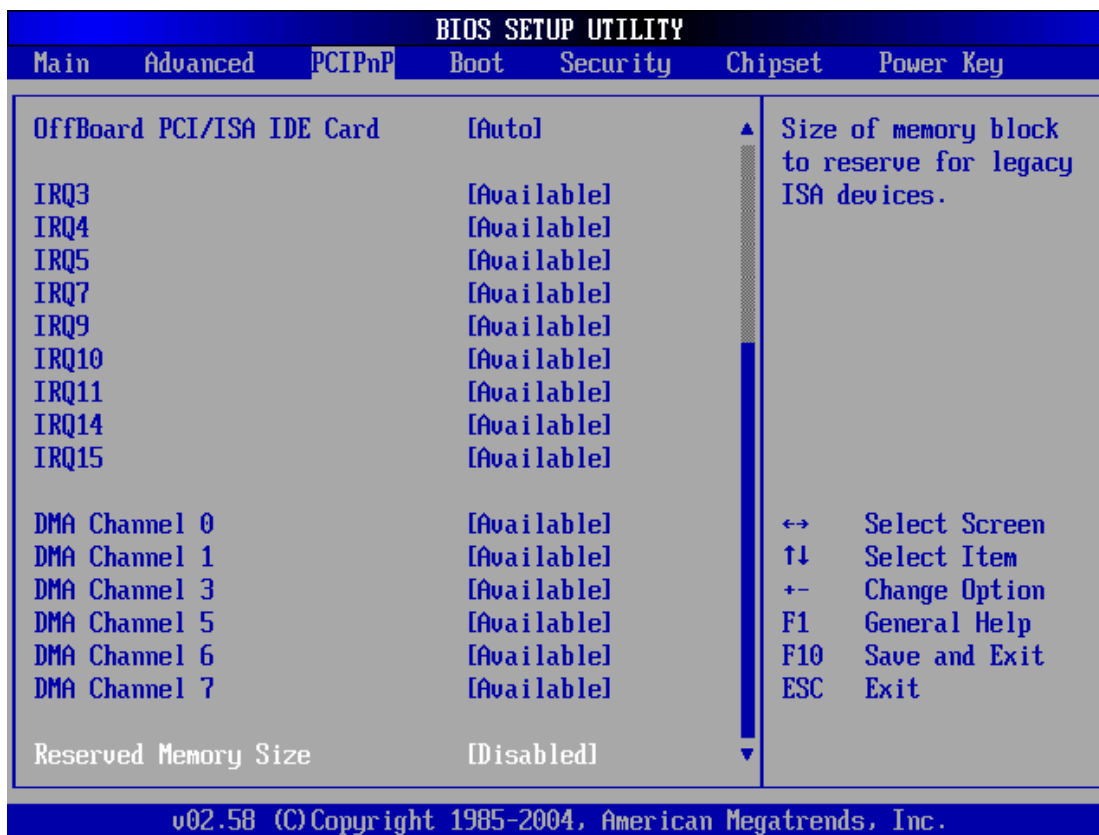

Options summary

| | | |
|--------------------------------|-----|-----------------------------------|
| Plug & Play O/S | No | Optimal Default, Failsafe Default |
| | Yes | |
| PCI Latency Timer | 32 | Optimal Default, Failsafe Default |
| | 64 | |
| | 96 | |
| | 128 | |
| | 160 | |
| | 192 | |
| | 224 | |
| | 248 | |
| Allocate IRQ to PCI VGA | Yes | Optimal Default, Failsafe Default |
| | No | |

| | | |
|----------------------------------|------------------|-----------------------------------|
| <i>Palette Snooping</i> | <i>Disable</i> | Optimal Default, Failsafe Default |
| | <i>Enable</i> | |
| <i>PCI IDE BusMaster</i> | <i>Disable</i> | Optimal Default, Failsafe Default |
| | <i>Enable</i> | |
| <i>OffBoard PCI/ISA IDE Card</i> | <i>Auto</i> | Optimal Default, Failsafe Default |
| | <i>PCI Slot1</i> | |
| | <i>PCI Slot2</i> | |
| | <i>PCI Slot3</i> | |
| | <i>PCI Slot4</i> | |
| | <i>PCI Slot5</i> | |
| | <i>PCI Slot6</i> | |
| <i>IRQ3</i> | <i>Available</i> | Optimal Default, Failsafe Default |
| | <i>Reserved</i> | |
| <i>IRQ4</i> | <i>Available</i> | Optimal Default, Failsafe Default |
| | <i>Reserved</i> | |
| <i>IRQ5</i> | <i>Available</i> | Optimal Default, Failsafe Default |
| | <i>Reserved</i> | |
| <i>IRQ6</i> | <i>Available</i> | Optimal Default, Failsafe Default |
| | <i>Reserved</i> | |
| <i>IRQ7</i> | <i>Available</i> | Optimal Default, Failsafe Default |
| | <i>Reserved</i> | |
| <i>IRQ8</i> | <i>Available</i> | Optimal Default, Failsafe Default |
| | <i>Reserved</i> | |
| <i>IRQ9</i> | <i>Available</i> | Optimal Default, Failsafe Default |
| | <i>Reserved</i> | |
| <i>IRQ10</i> | <i>Available</i> | Optimal Default, Failsafe Default |
| | <i>Reserved</i> | |

| | | |
|-----------------------------|------------------|-----------------------------------|
| IRQ11 | <i>Available</i> | Optimal Default, Failsafe Default |
| | <i>Reserved</i> | |
| IRQ12 | <i>Available</i> | Optimal Default, Failsafe Default |
| | <i>Reserved</i> | |
| IRQ13 | <i>Available</i> | Optimal Default, Failsafe Default |
| | <i>Reserved</i> | |
| IRQ14 | <i>Available</i> | Optimal Default, Failsafe Default |
| | <i>Reserved</i> | |
| IRQ15 | <i>Available</i> | Optimal Default, Failsafe Default |
| | <i>Reserved</i> | |
| DMA Channel 0 | <i>Available</i> | Optimal Default, Failsafe Default |
| | <i>Reserved</i> | |
| DMA Channel 1 | <i>Available</i> | Optimal Default, Failsafe Default |
| | <i>Reserved</i> | |
| DMA Channel 3 | <i>Available</i> | Optimal Default, Failsafe Default |
| | <i>Reserved</i> | |
| DMA Channel 5 | <i>Available</i> | Optimal Default, Failsafe Default |
| | <i>Reserved</i> | |
| DMA Channel 6 | <i>Available</i> | Optimal Default, Failsafe Default |
| | <i>Reserved</i> | |
| DMA Channel 7 | <i>Available</i> | Optimal Default, Failsafe Default |
| | <i>Reserved</i> | |
| <i>Reserved Memory Size</i> | <i>Disable</i> | Optimal Default, Failsafe Default |
| | <i>16k</i> | |
| | <i>32k</i> | |
| | <i>64k</i> | |
| | | |

Boot Settings

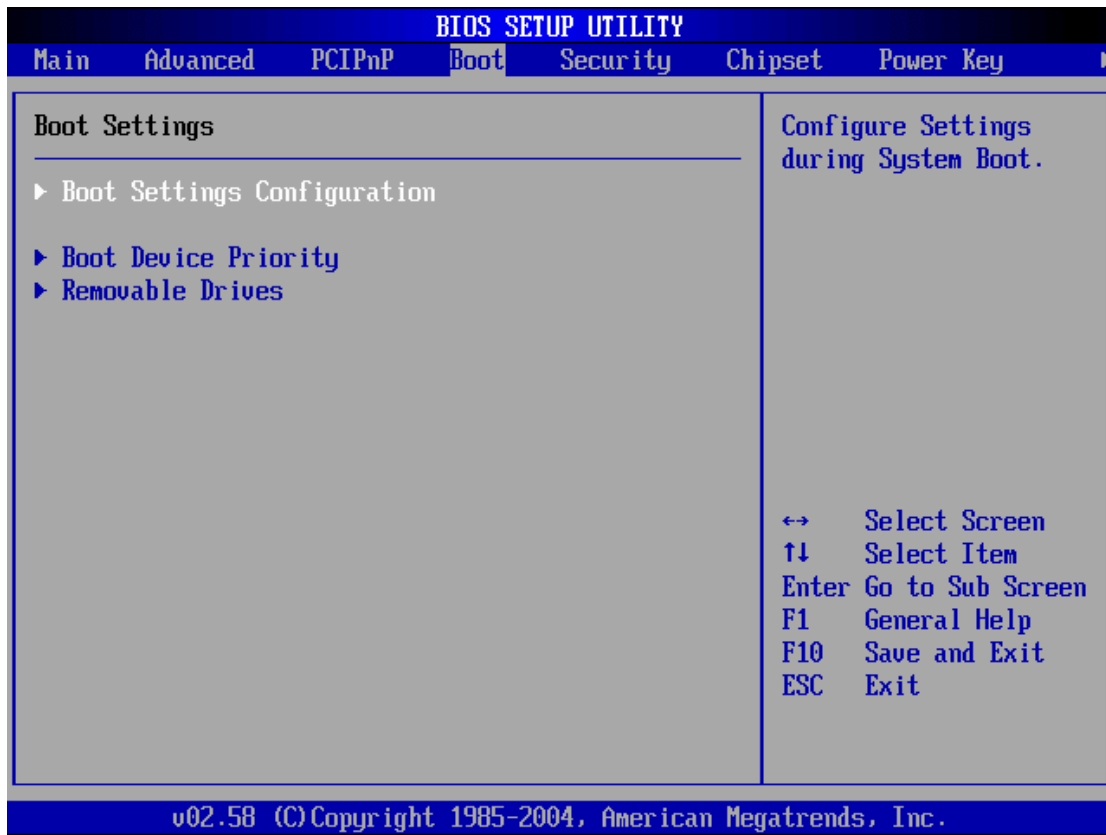

Note: Correction for Boot Settings screen capture above:

- Boot Settings Configuration
 - Boot Device Priority
 - Hard Disk Drives
 - CD/DVD Drives

Boot Settings Configuration



Options summary

| | | |
|-------------------------------|---------------------|-----------------------------------|
| Quick Boot | Enable | Optimal Default, Failsafe Default |
| | <i>Disable</i> | |
| Boot From LAN Support | <i>Disable</i> | Optimal Default, Failsafe Default |
| | Enable | |
| Quiet Boot | <i>Disable</i> | Optimal Default, Failsafe Default |
| | Enable | |
| AddOn ROM display Mode | Force BIOS | Optimal Default, Failsafe Default |
| | <i>Keep Current</i> | |
| Bootup Rum-Lock | <i>Off</i> | Optimal Default, Failsafe Default |
| | On | |

| | | |
|----------------------------------|----------------|-----------------------------------|
| <i>PS/2 Mouse Support</i> | <i>Disable</i> | Optimal Default, Failsafe Default |
| | <i>Enable</i> | |
| | <i>Auto</i> | |
| <i>Wait For 'F1' If Error</i> | <i>Disable</i> | Optimal Default, Failsafe Default |
| | <i>Enable</i> | |
| <i>Hit 'DEL' Message Display</i> | <i>Disable</i> | Optimal Default, Failsafe Default |
| | <i>Enable</i> | |
| <i>Interrupt 19 Capture</i> | <i>Disable</i> | Optimal Default, Failsafe Default |
| | <i>Enable</i> | |

Security Settings

BIOS SETUP UTILITY

Main Advanced PCI/PnP Boot **Security** Chipset Power Key

Security Settings

Supervisor Password :Not Installed
 User Password :Not Installed

Change Supervisor Password
 Change User Password
 Clear User Password

Boot Sector Virus Protection [Disabled]

Install or Change the password.

← Select Screen
 ↑↓ Select Item
 Enter Change
 F1 General Help
 F10 Save and Exit
 ESC Exit

v02.58 (C) Copyright 1985-2004, American Megatrends, Inc.

Options summary

| | | |
|---|----------------|-----------------------------------|
| <i>Change Supervisor Password</i> | | |
| <i>Change User Password</i> | | |
| <p>Change User/Supervisor Password You can install a Supervisor password, and if you install a supervisor password, you can then install a user password. A user password does not provide access to many of the features in the Setup utility.</p> <p>If you highlight these items and press Enter, a dialog box appears which lets you enter a password. You can enter no more than six letters or numbers. Press Enter after you have typed in the password. A second dialog box asks you to retype the password for confirmation. Press Enter after you have retyped it correctly. The password is required at boot time, or when the user enters the Setup utility.</p> | | |
| <i>Clear User Password</i> | | |
| <p>Highlight this item and type in the current password. At the next dialog box press Enter to disable password protection.</p> | | |
| <i>Boot Sector Virus Protection</i> | <i>Disable</i> | Optimal Default, Failsafe Default |
| | <i>Enable</i> | |

Advanced Chipset Settings



Northbridge Chipset Configuration

| NorthBridge Chipset Configuration | | Chipset |
|---|--------------------|---|
| DRAM Frequency | [Auto] | Options 200 Mhz 266 Mhz 333 Mhz Auto |
| Configure DRAM Timing by SPD | [Enabled] | |
| Init. Graphic Adapter Priority | [AGP/Int-VGA] | |
| Internal Graphics Mode Select | [Enabled, 32MB] | |
| Graphics Aperture Size | [64MB] | |
| Boot Display Device | [CRT+LFP] | |
| Flat Panel Type | [1280x1024 48bits] | |
| | | ↔ Select Screen ↑↓ Select Item +- Change Option F1 General Help F10 Save and Exit ESC Exit |
| v02.58 (C) Copyright 1985-2004, American Megatrends, Inc. | | |

Options summary

| | | |
|---------------------------------------|--------------|-----------------------------------|
| DRAM Frequency | 200 Mhz | Optimal Default, Failsafe Default |
| | 266 Mhz | |
| | 333 Mhz | |
| | Auto | |
| Configure DRAM Timing by SPD | Disable | Optimal Default, Failsafe Default |
| | Enable | |
| Init. Graphic Adapter Priority | Internal VGA | Optimal Default, Failsafe Default |
| | AGP/Int-VGA | |
| | AGP/PCI | |
| | PCI/AGP | |

| | | |
|-------------------------------------|--------------------------------|-----------------------------------|
| | <i>PCI/Int-VGA</i> | |
| <i>Internal Graphic Mode Select</i> | <i>Disable</i> | Optimal Default, Failsafe Default |
| | <i>Enable, 1MB</i> | |
| | <i>Enable, 4MB</i> | |
| | <i>Enable, 8MB</i> | |
| | <i>Enable, 16MB</i> | |
| | <i>Enable, 32MB</i> | |
| <i>Internal Aperture Size</i> | <i>64MB</i> | Optimal Default, Failsafe Default |
| | <i>128MB</i> | |
| | <i>256MB</i> | |
| <i>Boot Display Device</i> | <i>CRT</i> | Optimal Default, Failsafe Default |
| | <i>EFP</i> | |
| | <i>LFP</i> | |
| | <i>CRT+EFP</i> | |
| | <i>CRT+LFP</i> | |
| <i>Flat Panel Type</i> | <i>640x480LVDS</i> | Optimal Default, Failsafe Default |
| | <i>800x600LVDS</i> | |
| | <i>1024x768LVDS 24bits</i> | |
| | <i>1280x1024LVDS</i> | |
| | <i>1400x1050LVDS</i> | |
| | <i>1024x768LVDS 18bits</i> | |
| | <i>1600x1200 48bits</i> | |
| | <i>1280x1024 48bits</i> | |
| | <i>800x600 24bits</i> | |
| | <i>800x600 18bits</i> | |
| | <i>1024x768 37bits</i> | |

Southbridge Chipset Configuration

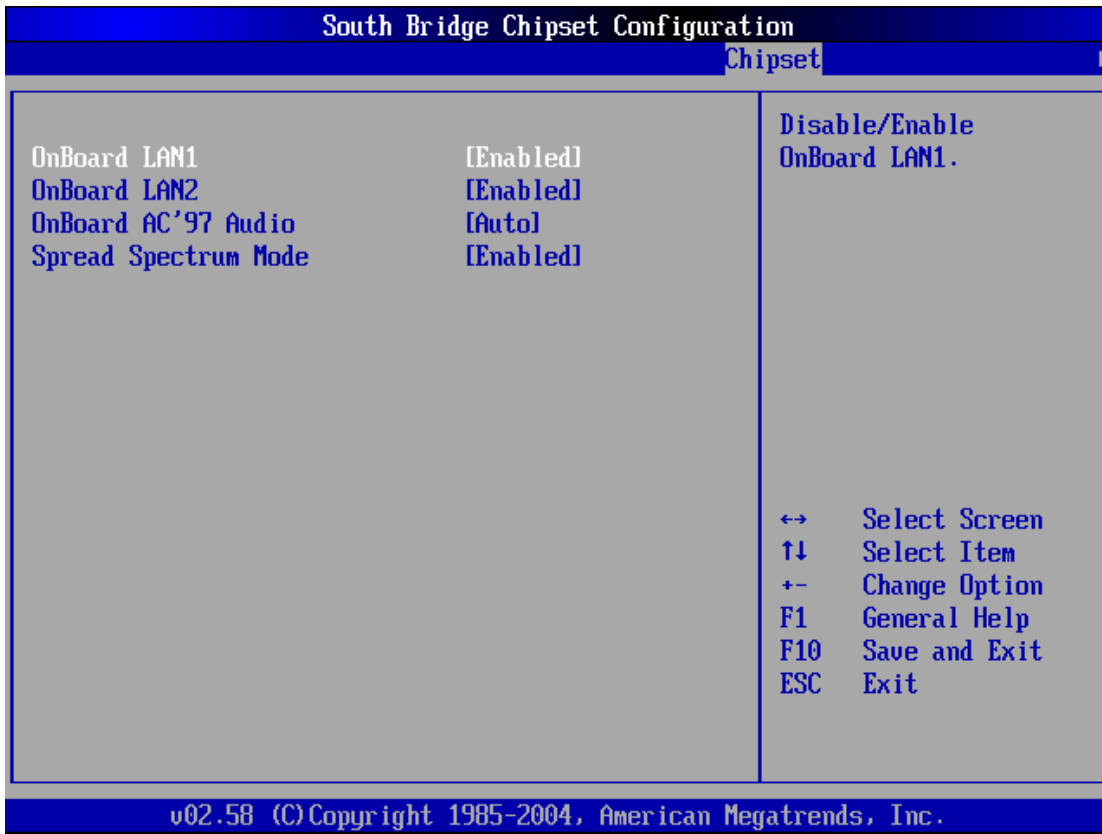

Options summary

| | | |
|-----------------------------|----------------|-----------------------------------|
| OnBoard LAN1 | Disabled | Optimal Default, Failsafe Default |
| | <i>Enable</i> | |
| OnBoard LAN1 | Disabled | Optimal Default, Failsafe Default |
| | <i>Enable</i> | |
| OnBoard AC'97 Audio | Auto | Optimal Default, Failsafe Default |
| | <i>Enable</i> | |
| Spread Spectrum Mode | <i>Disable</i> | Optimal Default, Failsafe Default |
| | <i>Enable</i> | |

Power Key Configuration

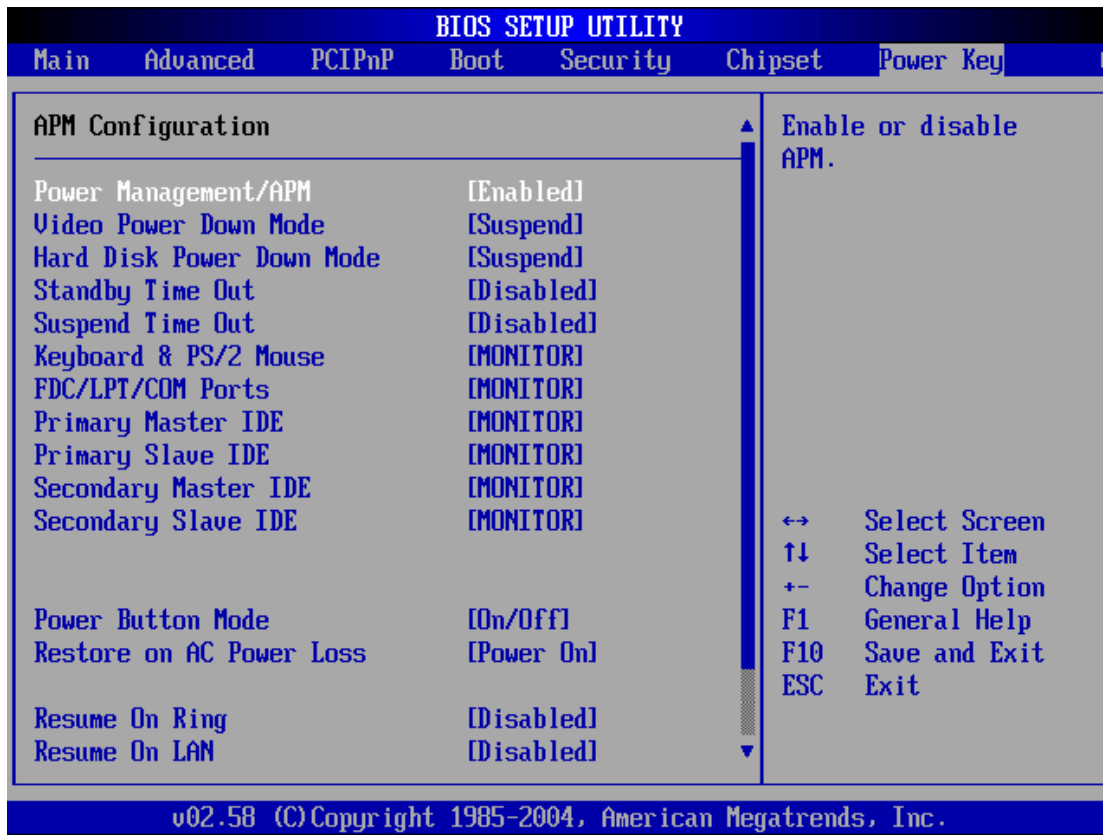

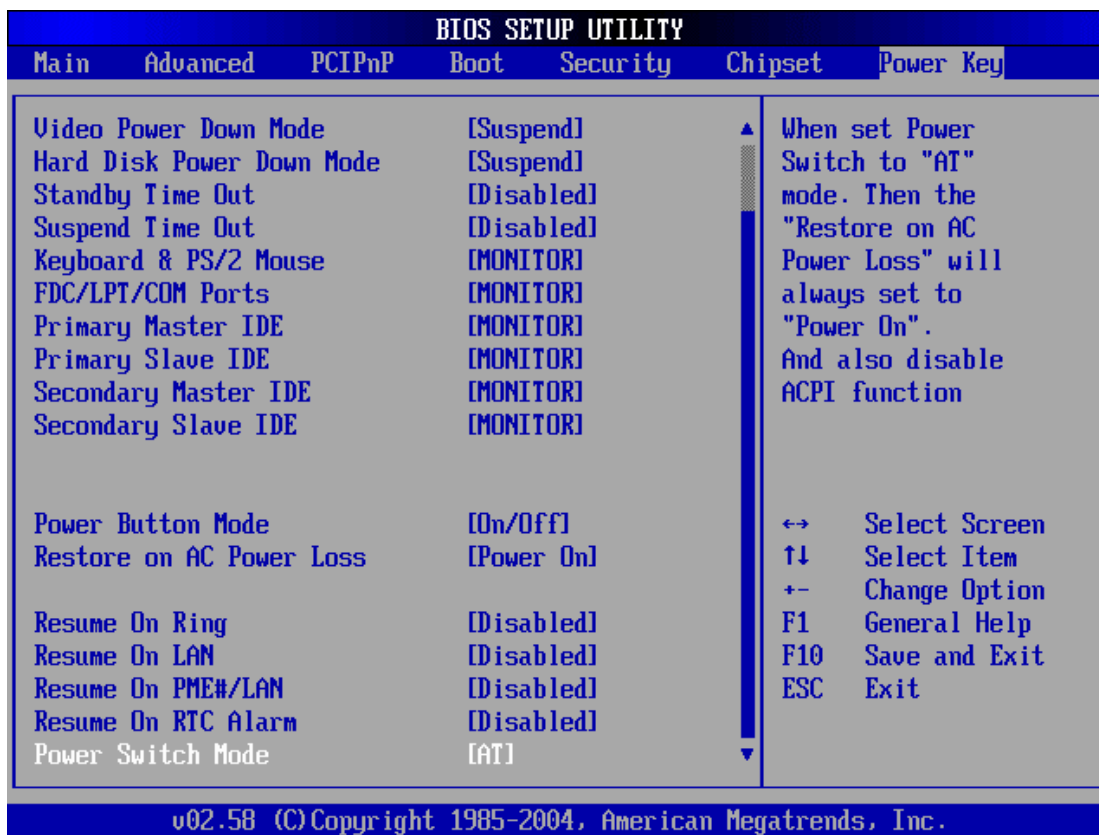

Options summary

| | | |
|----------------------------------|----------------|-----------------------------------|
| Power Management/APM | Disabled | Optimal Default, Failsafe Default |
| | <i>Enable</i> | |
| <i>Video Power Down Mode</i> | <i>Disable</i> | Optimal Default |
| | <i>Standby</i> | Failsafe Default |
| | <i>Suspend</i> | |
| <i>Hard Disk Power Down Mode</i> | <i>Disable</i> | Optimal Default |
| | <i>Standby</i> | Failsafe Default |
| | <i>Suspend</i> | |
| <i>Standby Time Out</i> | <i>Disable</i> | Optimal Default, Failsafe Default |
| | <i>1 Min</i> | |
| | <i>2 Min</i> | |
| | <i>4 Min</i> | |

| | | |
|----------------------------------|----------------|-----------------------------------|
| <i>Suspend Time Out</i> | <i>8 Min</i> | Optimal Default, Failsafe Default |
| | <i>10 Min</i> | |
| | <i>20 Min</i> | |
| | <i>30 Min</i> | |
| | <i>40 Min</i> | |
| | <i>50 Min</i> | |
| | <i>60 Min</i> | |
| | <i>Disable</i> | |
| | <i>1 Min</i> | |
| | <i>2 Min</i> | |
| | <i>4 Min</i> | |
| | <i>8 Min</i> | |
| | <i>10 Min</i> | |
| | <i>20 Min</i> | |
| | <i>30 Min</i> | |
| | <i>40 Min</i> | |
| | <i>50 Min</i> | |
| <i>60 Min</i> | | |
| <i>Keyboard & PS/2 Mouse</i> | <i>IGNORE</i> | Optimal Default, Failsafe Default |
| | <i>Monitor</i> | |
| <i>FDC/LPT/COM Ports</i> | <i>IGNORE</i> | Optimal Default, Failsafe Default |
| | <i>Monitor</i> | |
| <i>Primary Master IDE</i> | <i>IGNORE</i> | Optimal Default, Failsafe Default |
| | <i>Monitor</i> | |
| <i>Primary Slave IDE</i> | <i>IGNORE</i> | Optimal Default, Failsafe Default |
| | <i>Monitor</i> | |

| | | |
|---------------------------------|-------------------|-----------------------------------|
| <i>Secondary Master IDE</i> | <i>IGNORE</i> | Optimal Default, Failsafe Default |
| | <i>Monitor</i> | |
| <i>Secondary Slave IDE</i> | <i>IGNORE</i> | Optimal Default, Failsafe Default |
| | <i>Monitor</i> | |
| <i>Power Button Mode</i> | <i>On/Off</i> | Optimal Default, Failsafe Default |
| | <i>Suspend</i> | |
| <i>Restore on AC Power Loss</i> | <i>Power Off</i> | Optimal Default, Failsafe Default |
| | <i>Power On</i> | |
| | <i>Last State</i> | |
| <i>Resume On Ring</i> | <i>Disable</i> | Optimal Default, Failsafe Default |

Exit Options

| BIOS SETUP UTILITY | |
|--|---|
| ← Advanced PCIPnP Boot Security Chipset Power Key Exit | |
| Exit Options <hr/> Save Changes and Exit Discard Changes and Exit Discard Changes Load Optimal Defaults Load Failsafe Defaults | Exit system setup after saving the changes. F10 key can be used for this operation. ↔ Select Screen ↑↓ Select Item Enter Go to Sub Screen F1 General Help F10 Save and Exit ESC Exit |
| v02.58 (C) Copyright 1985-2004, American Megatrends, Inc. | |

Options summary

| | |
|--|--|
| <i>Save Change and Exit</i> | Highlight this item and press Enter to save any changes that you have made in the Setup utility and exit the Setup utility. When the Save Settings and Exit dialog box appears, select [OK] item to save the changes and exit, or press [Cancel] to return to the setup main menu. [F10] key can be used for this operation. |
| <i>Discard Changes and Exit</i> | Highlight this item and press Enter to discard any changes that you have made in the Setup utility and exit the Setup utility. When the Exit Discarding Changes dialog box appears, press [OK] to discard changes and exit, or press [Cancel] to return to the setup main menu. [ESC] key can be used for this operation. |
| <i>Discard Changes</i> | If you highlight this item and press Enter , a dialog box asks if you want to discard the settings changes for all the items in the Setup utility. Select the [OK] item to indicate Yes, and then press Enter to bypass the optimal settings changes |
| <i>Load Optimal Defaults</i> | If you highlight this item and press Enter , a dialog box asks if you want to install optimal settings for all the items in the Setup utility. Select the [OK] item to indicate Yes, and then press Enter to install the optimal settings. [F9] key can be used for this operation. |
| <i>Load Failsafe Defaults</i> | Load Failsafe Default values for all the setup questions. [F8] key can be used for this operation.. |

Chapter 4 – Maintenance

The 4117T is designed to withstand the harsh environment of the factory floor. Routine maintenance can help keep your system in good operating condition. Preventive maintenance consists of several basic procedures that will greatly reduce the chance of system malfunction. Schedule preventive maintenance along with the regular equipment maintenance to minimize down time.

General Preventive Maintenance

Here are some preventive measures you can take:

- Clean the monitor screen using a non-residue cleaner such as a mild window cleaning solution or CRT screen cleaner. Take care not to scratch the screen face.
- *Remove dust and dirt from PC components.* If dust builds up on heat sinks and circuitry, an obstruction of heat dissipation could cause the unit to malfunction. If dust reaches the electronic boards, a short circuit could occur.
- *Check the connections to I/O modules,* especially in environments where vibration could loosen the connections. Check to see that all plugs, sockets, terminal strips, and module connections are solid.
- *Remove unnecessary articles, such as drawings or manuals, from the unit.* They can obstruct airflow and create hot spots, which cause the system to malfunction.
- *Do not place noise-generating equipment near the 4117T unit.*

Fuse Replacement

The 4117T unit has no accessible fuse. Return the unit to the factory for fuse replacement.

Recommended Hard Drive Preventive Maintenance

Pro-face has recognized that hard drive failures may begin to increase an average of four to five years into the life of most computers used in industrial applications. Therefore, it is our recommendation as a preventive maintenance measure that all hard drives used in these types of applications be replaced at a two year interval to avoid any down time related to hard drive failure.

The purpose of this message is to merely bring this to our customer's attention, to offer alternative solutions, and to provide all of our customers with the excellent service they deserve.

Any questions regarding this issue may be directed to our support center at support@profaceamerica.com.

Please note: Pro-face recommends frequent backups of your hard drive, especially before beginning preventive maintenance procedures.

Product Repair Program / Returning a Unit to Pro-face

Pro-face's Product Repair & Customization Department (PR&C) restores equipment to normal operating condition and implements engineering changes that enhance operating specifications. Pro-face tests products returned to Pro-face with the standard Pro-face test diagnostics.

Note

Before sending the unit in for repair, back up the hard drive in case Pro-face needs to restore the hard drive to the factory default O/S load.

Follow the steps below to prepare the unit for shipment:

1. Obtain an Return Merchandise Authorization (RMA) number for your unit by visiting the Pro-face RMA Request web page and fill out the online request form:

<http://www.profaceamerica.com/rma/>

If you cannot fill out the online form, there is an RMA Request Form Document that can be downloaded and either E-mailed (support@profaceamerica.com) or Faxed (734-429-1010) to the Pro-face Customer Support Team.

If you have difficulty then please call the Pro-face Customer Support Team at (734) 944-0482).

2. Please have the following information:
 - Company name, shipping and billing address
 - Type of service desired: product repair or product exchange
 - Product model number, part number, quantity, serial number(s), and warranty status
 - Failure mode and failure systems
 - Purchase order number or repair order number
3. Make sure the front panel assembly is properly attached to the unit.
4. Attach failure information to the unit to speed processing.
5. Place the unit securely in its original packaging or an equivalent heavy-duty box.
6. Mark the RMA number on your purchase order and on the outside of the box.
7. Send the unit to the address given when you receive your RMA number.

Chapter 5 – Troubleshooting

Diagnostic Testing

If you suspect that you are having hardware problems with your 4117T, you can use the Pro-face diagnostic utility to check out the PC's various ports and subsystems. The diagnostic utility is on the Documentation and Support Library CD that was included with the your unit.

The first step is to create a diagnostic diskette. The following steps can be done on any computer with a CD-ROM drive:

1. Create a DOS-bootable diskette
2. Create a temporary folder on the computer hard drive
3. There is a self-extracting zip file on the Documentation and Support Library CD located in:

DRIVERS\utility\xydiag

Run that program and extract the files to the temporary folder you just created.

4. Copy the extracted files onto the DOS-bootable diskette.

When you have created the diskette, insert it into an external floppy drive, connect it to the 4117T and re-boot the unit. The menu in Figure 5–2, *Main Menu*, will appear following boot-up. Additional information on the tests is included in the .txt files on the diskette.

Perform the following steps **before** starting the system tests:

1. Place the CPU board jumpers and switches to the factory set positions.
2. Plug the female end of the AC power cable into the side of the unit and the male end into a properly grounded outlet.
3. Connect the serial loopback connector(s) and the printer cable to the appropriate connectors, and connect a PC/AT or PS/2 keyboard. Figure 5–1, *Serial Loopback Connections*, illustrates the wiring necessary for the loopback connection.
4. Default the CMOS setup to the factory settings.

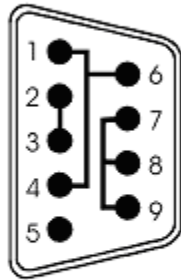

Com 1 RS-232
Serial Loopback
Connections

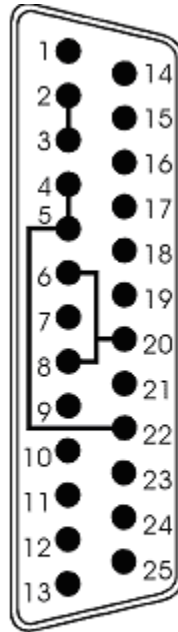

Com 2 RS-232
Serial Loopback
Connections

Figure 5-1. Serial Loopback Connections

Running the Tests

To run the test, insert the diagnostics disk into drive A. Turn on the computer (the diagnostics program will boot-up). Figure 5–2 shows the Main Menu.

```

          Copyright xxxx, <Company Name> All rights reserved.
          Diagnostic Tests Sequence/Selection Menu (Rel. xx)
1. WILL pause on error           5. Auto-select tests
2. SINGLE PASS test mode        6. Deselect all tests
3. Save setup to file           7. Quit and exit to DOS
4. Extract setup from a file     8. Return to previous screen

A) RAM Test
B) Video RAM Test
C) Extended RAM Test
D) Real Time Clock Test
E) COM1 Serial Port Test
F) COM2 Serial Port Test
G) COM3 Serial Port Test
H) COM4 Serial Port Test
I) Math Coprocessor Test
J) Video Adjustments Test

K) Video Interface Test
L) Speaker Port Test
M) LPT1: Printer Port Test
N) LPT2: Printer Port Test
O) C: Hard Drive Interface Test
P) D: Hard Drive Interface Test
Q) A: Floppy Drive Interface Test
R) B: Floppy Drive Interface Test
S) Keyboard, Keypad Tests
   = = Test Selected

[ENTER]=START TESTING

Use the letters to move the cursor and select/deselect, or use the arrow
keys to move, then use the [SPACE] key to select/deselect a test or
function.

```

Figure 5-2. Main Menu

Note

Please read the DIAG.TXT file on the diagnostics disk for detailed information about the tests.

Note

Avoid repeated running of any hard disk diagnostic utility if you use the Solid State (Flash) drive option. The Flash drive has a limited number of writes to each logical sector. Repeated writes from a diagnostic utility will prematurely shorten the life of the drive.

Reinstalling Operating Systems

The 4117T CPU ships with Windows 2000 or Windows XP Professional operating systems installed. If you want to install a different operating system, refer to that operating system's manual for directions.

Note

If you need to reinstall the Windows 98, Windows 2000, Windows NT, or Windows XP Professional operating system, you must have an internal CD-ROM drive or an external parallel port CD-ROM drive. Windows NT and Windows XP ship only on CD-ROM.

Windows® 2000 Reinstallation

If you need to reinstall the Windows 2000 operating system, refer to the *Pro-face/Xycom Workstation Recovery Media Software Installation Instructions for Microsoft® Windows® 2000* (shipped with systems preinstalled with Windows 2000). This document is devoted to the reinstallation of your Windows 2000 operating system and drivers utilizing the Recovery Media provided with your Pro-face/Xycom industrial computer.

Note

This procedure assumes that the computer hard disk drive has been completely corrupted or replaced.

Warning

This procedure will destroy data that may exist on the hard disk drive.

Windows XP® Reinstallation

If you need to reinstall the Windows® XP operating system, refer to the *Pro-face/Xycom Workstation Software Installation Instructions For Microsoft Windows XP* (shipped with systems preinstalled with Windows XP). This document is devoted to the reinstallation of your Windows XP operating system and drivers, utilizing the XP CD provided with your Pro-face/Xycom industrial computer. If you want to install a new operating system or reinstall a current operating system, refer to the Windows XP Professional CD-ROM (shipped with systems preinstalled with Windows XP Professional).

Note

This procedure assumes that the computer hard disk drive has been completely corrupted or replaced.

Warning

This procedure will destroy data that may exist on the hard disk drive.

If you want to install a new operating system or reinstall a current operating system, refer to the operating system's manual for directions.

Installing Drivers

This section describes how to install the drivers associated with the system.

Note

For further assistance, call Pro-face technical support at 734-944-0482.

Video Drivers

Video drivers and the expansion utilities are on the Documentation and Support Library CD included with the documentation kit.

Choose the video driver for your operating system from the following directory on the Documentation and Support Library CD:

\\DRIVERS\\VIDEO\\INTEL\\855GME

Touch Screen Drivers

If you have a touch screen driver that has been factory installed, you will also receive, pre-loaded and at no extra charge: Windows 2000, and Windows XP Professional touch screen drivers.

Note

If you ordered a system pre-loaded with an operating system, the touch screen driver was pre-installed.

You must install the corresponding touch screen driver software if you change the operating system. The touch screen drivers are located on the Document and Support Library CD under:

\\DRIVERS\TOUCHSREEN\TOUCHKIT

Miscellaneous Drivers

Refer to your operating system and peripheral manuals for information on installing drivers related to these items.

Note

If you ordered a system with Windows pre-loaded, you may have to purchase and install an external parallel port CD-ROM drive, or order your system with a CD-ROM drive pre-installed, to be able to install Windows drivers. The Windows operating system ships only on CD-ROM.

Appendix A Technical Specifications

This section contains the hardware and environmental specifications for the 4117T.

Hardware Specifications

The following table lists the hardware specifications for the 4117T.

Table A - 1. Hardware and Compliance Specifications

| Characteristic | Specification |
|-----------------------|--|
| Mechanical | |
| Height | 13.99" (355.25 mm) |
| Width | 17.79" (451.614 mm) |
| Depth | 5.32" (135.20 mm) overall 4.94" (125.41 mm) behind front panel 0.385" (9.79 mm) front panel protrusion |
| Weight | 21.3 lbs (9.66 kg) |
| Electrical | |
| AC | 100-240 VAC 50\60 Hz 1.0A 95W *Nominal |
| Power Supply | 200 watts |
| Mounting | Panel mount or 19" rack mount |
| Flat Panel | 17" TFT active color display |
| Agency Approvals | UL 508 (Listed), E300525 cUL CSA C22.2, No. 142 (Listed), E300525 |
| Regulatory Compliance | FCC 47 CFR, Part 15, Class A CE EMI EN55022, Class A IMMUNITY EN61000-6-2 SAFETY IEC60950-1 HARMONICS EN61000-3-2, Class A FLICKER EN61000-3-3 |
| ROHS | Compliant |

* Nominal Power is measured for a base configuration only. Any additional expansion and/or devices will increase the input power required.

Environmental Specifications

Table A-2 lists the environmental and compliance specifications for the 4117T.

Table A-2. Environmental Specifications

| | | |
|------------------------------------|---------------|---|
| Temperature | Operating | 0°C to 50°C (32°F to 122°F) |
| | Non-operating | -20°C to 60°C (-4°F to 140°F) |
| Humidity | Operating | 20% to 80% RH, non-condensing |
| | Non-operating | 5% to 95% RH, non-condensing |
| Shock ¹ | Operating | 15g peak acceleration, 11 msec duration |
| | Non-operating | 30g peak acceleration, 11 msec duration |
| Vibration (5-2000 Hz) ¹ | Operating | 0.006" peak to peak displacement 1.0g maximum acceleration |
| | Non-operating | 0.015" peak to peak displacement 2.5g maximum acceleration |
| Altitude ² | Operating | Sea level to 10,000 ft. (3,000 m) |
| | Non-operating | Sea level to 40,000 ft. (12,000 m) |

¹ These values are with solid state hard drives and not rotating media drives.

² Consistent with internal component specifications.

Appendix B – Power-On Self-Test Messages

POST Messages

During the Power-On Self-Test (POST) if the BIOS detects an error, it will either sound a beep code or display a message.

If a message is displayed, it will be accompanied by:

PRESS F1 TO CONTINUE, CTRL-ALT-ESC OR DEL TO ENTER SETUP

POST Beep

There are two kinds of beep codes in BIOS:

Single long beep followed by three short beeps—This code indicates that a video error has occurred and the BIOS cannot initialize the video screen to display any additional information.

Repeating long beep—This code indicates that a DRAM error has occurred.

Error Messages

One or more of the following messages may be displayed if the BIOS detects an error during the POST. This list includes messages for both the ISA and the EISA BIOS.

Table B-1. Error Messages

| Error Messages | Cause/Solution |
|---|---|
| CMOS BATTERY HAS FAILED | CMOS battery is no longer functional. It should be replaced. |
| CMOS CHECKSUM ERROR | Checksum of CMOS is incorrect. A weak battery may have caused this error; replace if necessary. It may also indicate that CMOS has become corrupt. |
| DISK BOOT FAILURE, INSERT SYSTEM DISK AND PRESS ENTER | No boot device was found. This could mean that either a boot drive was not detected or the drive does not contain proper system boot files. Insert a system disk (formatted as a boot device) into Drive A: and press Enter. If you assumed the system would boot from the hard drive, make sure the controller is inserted correctly and all cables are properly attached, then reboot the system. |
| DISKETTE DRIVES OR TYPES MISMATCH ERROR - RUN SETUP | Type of diskette drive installed in the system is different from the CMOS definition. Run Setup to reconfigure the drive type correctly. |
| DISPLAY SWITCH IS SET INCORRECTLY | The display switch on the motherboard is set to a different setting than indicated in Setup. Determine which setting is correct and then either turn off the system and change the jumper, or enter Setup and change the VIDEO selection. |
| DISPLAY TYPE HAS CHANGED SINCE LAST BOOT | Since the last powering off the system, the display adapter has been changed. You must configure the system for the new display type. |

| Error Messages | Cause/Solution |
|---|--|
| EISA CONFIGURATION CHECKSUM ERROR PLEASE RUN EISA CONFIGURATION UTILITY | The EISA non-volatile RAM checksum is incorrect or cannot correctly read the EISA slot. This can indicate either the EISA non-volatile memory has become corrupt or the slot has been configured incorrectly. Verify the card is installed firmly in the slot. When this error appears, the system will boot in ISA mode allowing you to run the EISA Configuration Utility. |
| EISA CONFIGURATION IS NOT COMPLETE PLEASE RUN EISA CONFIGURATION UTILITY | The slot configuration information stored in the EISA non-volatile memory is incomplete. When this error appears, the system will boot in ISA mode allowing you to run the EISA Configuration Utility. |
| ERROR ENCOUNTERED INITIALIZING HARD DRIVE | Check that the adapter is installed correctly and all cables are firmly attached. Verify that the correct hard drive type is selected in Setup. |
| ERROR INITIALIZING HARD DISK CONTROLLER | See the cord is correctly and firmly installed in the bus. Verify the correct hard drive type is selected in Setup. Check jumper settings on the hard drive. |
| FLOPPY DISK CNTRLR ERROR OR NO CNTRLR PRESENT | Make sure the controller is installed correctly and firmly. If there are no floppy drives installed, be sure the Diskette Drive selection in Setup is set to NONE. |
| INVALID EISA CONFIGURATION PLEASE RUN EISA CONFIGURATION UTILITY | The non-volatile memory containing EISA configuration information was programmed incorrectly or has become corrupt. The system will boot in ISA mode allowing you to run the EISA Configuration Utility and correctly program the memory. |
| KEYBOARD ERROR OR NO KEYBOARD PRESENT | Make sure the keyboard is attached correctly and no keys are being pressed during the boot. If you are purposely configuring the system without a keyboard, set the error halt condition in Setup to HALT ON ALL, BUT KEYBOARD. This will cause the BIOS to ignore the missing keyboard and continue the boot. |
| KEYBOARD IS LOCKED OUT - UNLOCK THE KEY | BIOS detected the keyboard is locked. P17 of keyboard controller is pulled low. |
| MEMORY ADDRESS ERROR AT ... | Indicates a memory address error at a specific location. You can use this location along with the memory map for your system to find and replace the bad memory chips. |
| MEMORY PARITY ERROR AT ... | Indicates a memory parity error at a specific location. You can use this location along with the memory map for your system to find and replace the bad memory chips. |
| MEMORY SIZE HAS CHANGED SINCE LAST BOOT | Memory has been added or removed since the last boot. In EISA mode use Configuration Utility to reconfigure the memory configuration. In ISA mode enter Setup and enter the new memory size in the memory fields. |
| MEMORY VERIFY ERROR AT ... | Indicates an error verifying a value already written to memory. Use the location along with your system's memory map to locate the bad chip. |
| OFFENDING ADDRESS NOT FOUND | This message is used in conjunction with the I/O CHANNEL CHECK and RAM PARITY ERROR messages when the segment that has caused the problem cannot be isolated. |
| OFFENDING SEGMENT | This message is used in conjunction with the I/O CHANNEL CHECK and RAM PARITY ERROR messages when the segment that has caused the problem has been isolated. |
| PRESS A KEY TO REBOOT | This will be displayed at the bottom screen when an error occurs that requires you to reboot. Press any key to reboot. |
| PRESS F1 TO DISABLE NMI, F2 TO REBOOT | When BIOS detects a Non-maskable Interrupt condition during boot, this will allow you to disable the NMI and continue to boot, or you can reboot the system with the NMI enabled. |
| RAM PARITY ERROR - CHECKING FOR SEGMENT | Indicates a parity error in Random Access Memory. |
| SHOULD BE EMPTY BUT EISA BOARD FOUND PLEASE RUN EISA CONFIGURATION UTILITY | A valid board ID was found in a slot that was configured as having no board ID. When this error appears, the system will boot in ISA mode allowing you to run the EISA Configuration Utility. |
| SHOULD HAVE EISA BOARD BUT NOT FOUND PLEASE RUN EISA CONFIGURATION UTILITY | The board installed is not responding to the ID request, or no board ID has been found in the indicated slot. When this error appears, the system will boot in ISA mode allowing you to run the EISA Configuration Utility. |
| SLOT NOT EMPTY | A slot designated as empty by the EISA Configuration Utility actually contains a board. When this error appears, the system will boot in ISA mode allowing you to run the EISA Configuration Utility. |

| Error Messages | Cause/Solution |
|---|---|
| SYSTEM HALTED, (CTRL-ALT-DEL) TO REBOOT ... | The present boot attempt has been aborted and the system must be rebooted. Press and hold down the CTRL and ALT keys and press DEL. |
| WRONG BOARD IN SLOT PLEASE RUN EISA CONFIGURATION UTILITY | The board ID does not match the ID stored in the EISA non-volatile memory. When this error appears, the system will boot in ISA mode, allowing you to run the EISA Configuration Utility. |
| FLOPPY DISK(S) FAIL (80) | Unable to reset floppy subsystem |
| FLOPPY DISK(S) FAIL (40) | Floppy type mismatch |
| HARD DISK(S) FAIL (80) | HDD reset failed |
| HARD DISK(S) FAIL (40) | HDD controller diagnostics failed |
| HARD DISK(S) FAIL (20) | HDD initialization error |
| HARD DISK(S) FAIL (10) | Unable to recalibrate fixed disk |
| HARD DISK(S) FAIL (08) | Sector Verify failed |
| MANUFACTURING POST LOOP. | System will repeat POST procedure infinitely while the P15 of keyboard controller is pulled low. This is also used for M/B burn in test. |
| BIOS ROM CHECKSUM ERROR - SYSTEM HALTED. | The checksum of ROM address F0000H-FFFFFH is bad. |
| MEMORY TEST FAIL. | BIOS reports the memory test failed if the onboard memory is tested error. |

Appendix C – How to Upgrade a New BIOS

Please contact the Pro-face Application Engineering Department at 734-944-0482 to obtain the latest BIOS.

BIOS Update Procedure

Notes

- A. This procedure will erase any prior data on that floppy, so please proceed accordingly.
- B. Typically four files will be transferred, only COMMAND.COM being visible when running a simple directory listing.
- C. Please leave the diskette un-write protected for the balance of this procedure.

1. Make a boot disk. Go to the DOS command prompt in MS-DOS or Windows 9x and, with an available floppy disk in "A", type "format A:/s" That will format the floppy and transfer the needed system files to it.
2. Download the BIOS upgrade file and awdfash.exe utility from an ICP web site to a temporary directory on your hard drive, or directly to the floppy formatted in step 1.
3. Copy (BIOS file and awdfash.exe) files to the boot floppy disk.
4. Reboot the system to the DOS command prompt using the boot disk made in the previous steps.
5. At the DOS command prompt, awdfash filename.xxx, (filename.xxx is the file name of the upgraded BIOS file), press Enter.
6. The first prompted option is to save the old BIOS. It is recommended that this option be selected in case it is later decided not to use the new version once it is installed. To save, enter Y. To not save, enter N.

Notes

A. DO NOT save the old BIOS with the same file name as the new BIOS. If the same file name is used, the new BIOS will write over the old BIOS with no prompted warning.

B. If the old BIOS is not saved write down the version number of the old BIOS and store it with your important computer documents. If not saving old BIOS, enter N (for "no") and skip to step 9.

7. Enter a NEW name for the old BIOS file, press Enter.
8. The second prompted option will be whether you want to flash your BIOS. Enter Y for yes, N for no.

Warning

Once the Enter key is pressed, DO NOT touch the keyboard, reset button, or power switch while flashing is in progress. A progress bar on the screen will show the progress of the flashing.

9. When the flashing process is complete, you will be asked to reset or power off the system. Remove the floppy disk from the drive and reset or power off the system.
10. Reboot the system and note that the BIOS version on the initial boot-up screen has changed to the new BIOS version. Your BIOS upgrade is now complete.

Recovering Your Old BIOS

1. Boot the system with the floppy disk that contains the new BIOS. If you do not have the floppy disk, repeat steps 1, 2, and 3 of the BIOS Upgrade Procedure above for the version of the BIOS recovering.
2. Complete steps 4 and 5 (filename.xxx is the name of the recovered BIOS file). Select N for no in step 6, and continue with steps 8, 9, and 10.

Install screen:

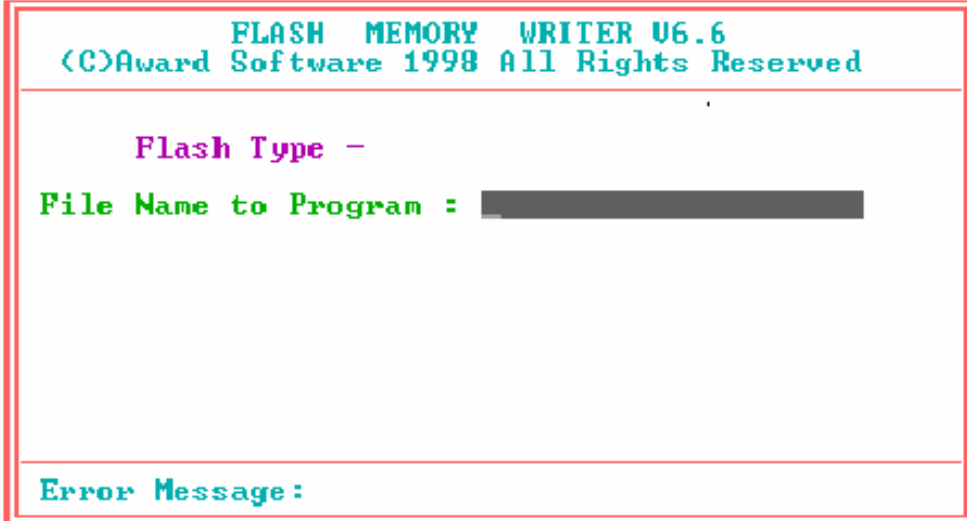

Figure C - 1. BIOS Upgrade Screen

Index

| | | | |
|--|------------|---------------------------------------|--------|
| 17" TFT LCD | 18 | driver | 66 |
| AC '97 | 14 | operating systems | 65 |
| ACPI Power Management | 14 | Intel® 855GME | 14, 15 |
| AGP 4X | 14 | Intel® ICH4 | 14 |
| Application Accelerator | 14 | LAN | 14 |
| Arm mounting | 13 | LCD display | |
| Award BIOS setup | 14 | specifications | 2 |
| BIOS | 17 | LCD voltage setup | 18 |
| BIOS recovery | 74 | Maintenance | 60 |
| BIOS setup | 14 | general | 60 |
| overview | 28 | hard drive | 60 |
| starting | 28 | Mechanical dimensions | 8 |
| using | 30 | motherboard | 19 |
| BIOS upgrades | 73 | Mounting | |
| CF card setup | 18 | arm | 13 |
| clear CMOS | 17, 18 | panel | 9 |
| CMOS data | 17 | wall | 11 |
| Compact Flash Connector | 21 | Operating systems | |
| CPU | 17, 27 | installation | 65 |
| CPU board | 14 | panel | 19 |
| layout | 16 | Panel mounting | 9 |
| product overview | 14 | PCI Local Bus Specification | 14 |
| Dimensions | | peripheral interface connectors | 19 |
| mechanical | 8 | POST messages | 70 |
| Documentation kit | 5 | Power on self test | 70 |
| Drivers | | error messages | 70 |
| installing | 66 | POST beep | 70 |
| miscellaneous | 67 | POST messages | 70 |
| touch screen | 66 | Preventive maintenance | 60 |
| video | 66 | general | 60 |
| Enhanced DMA controller | 14 | hard drive | 60 |
| Environmental specifications | 69 | Product information | |
| Error messages (power on self test | 70 | CPU board | 14 |
| Extreme Graphics 2 | 14 | environmental specifications | 69 |
| Fuse | | general | 1 |
| replacement | 60 | LCD display | 2 |
| General information | 1 | mechanical dimensions | 8 |
| HDD | 20, 21, 22 | touch screen | 2 |
| Installation | | | |

| | |
|-------------------------------|------|
| Product specifications | |
| environmental | 69 |
| LCD display | 2 |
| touch screen | 2 |
| Recovering the old BIOS | 74 |
| Repairs and service | 61 |
| Reverse side of unit | |
| system setup | 2, 3 |
| screen | 18 |
| serial port | 18 |
| Service and repairs | 61 |
| Side view of unit | |
| system setup | 4 |
| Specifications | |
| environmental | 69 |
| LCD display | 2 |
| touch screen | 2 |
| system bus | 14 |
| System setup | |
| arm mounting | 13 |
| panel mounting | 9 |
| reverse side of unit | 2, 3 |
| side view of unit | 4 |
| wall mounting | 11 |
| Touch screen | |
| specifications | 2 |
| Touch screen drivers | 66 |
| Unit reverse side | 2, 3 |
| Unit side view | 4 |
| Upgrading the BIOS | 73 |
| USB 2.0 | 14 |
| USB host controllers | 14 |
| Video drivers | 66 |
| Wall mounting | 11 |

144811(B)

Xycom Automation, L.L.C.

734-429-4971

Fax: 734-429-1010

<http://www.profaceamerica.com>

Fax: 734-429-1010

<http://www.profaceamerica.com>

Canada Sales: 905-607-3400

Northern Europe Sales: +44-1604-790-767

Southern Europe Sales: +39-011-770-53-11

Northern Europe Sales: +44-1604-790-767

Southern Europe Sales: +39-011-770-53-11

