

4700 Series

Flat Panel Industrial PCs

User Manual for the 4715T,
4715KPM, & 4715KPMT Models

Revision	Description	Date
A	Manual Released	9/06
B	Name change, correct where applicable with document	4/07

Part Number 144813(A)

Trademark Information

Xycom and Xycom Automation are trademarks of Xycom Automation, L.L.C.

Xycom Automation, L.L.C. now is referred to as Pro-face through a D.B.A. The Pro-face name and logo will replace the Xycom name and logo on all documents where possible.

Pro-face is a trademark of Digital Electronics Corporation.

Brand or product names are trademarks or registered trademarks of their respective owners. Intel and Pentium are registered trademarks and Celeron is a trademark of Intel Corporation. Windows, Windows NT, and Windows XP are registered trademarks of Microsoft Corporation in the U.S. and in other countries.

Copyright Information

This document is copyrighted by Xycom Automation, L.L.C. (Xycom) and shall not be reproduced or copied without expressed written authorization from Xycom Automation, L.L.C.

The information contained within this document is subject to change without notice. Pro-face does not guarantee the accuracy of the information.

United States FCC Part 15, Subpart B, Class A EMI Compliance Statement:

NOTE: This equipment has been tested and found to comply with the limits for a Class A digital device, pursuant to part 15 of the FCC Rules. These limits are designed to provide reasonable protection against harmful interference when the equipment is operated in a commercial environment. This equipment generates, uses, and can radiate radio frequency energy and, if not installed and used in accordance with the instruction manual, may cause harmful interference to radio communications. Operation of this equipment in a residential area is likely to cause harmful interference in which case the user will be required to correct the interference at the user's expense.

For European Users – WARNING:

This is a Class A product. In a domestic environment this product may cause radio interference in which case the user may be required to take adequate measures.

INSTALLATION – Electromagnetic Compatibility WARNING:

The connection of non-shielded equipment interface cables to this equipment will invalidate FCC EMI and European Union EMC compliance and may result in electromagnetic interference and/or susceptibility levels which are in violation of regulations applying to the legal operation of this device. It is the responsibility of the system integrator and/or user to apply the following directions relating to installation and configuration:

All interface cables must include shielded cables. Braid/foil type shields are recommended. Communication cable connectors must be metal, ideally zinc die-cast backshell types, and provide 360-degree protection about the interface wires. The cable shield braid must be terminated directly to the metal connector shell; ground drain wires alone are not adequate.

Protective measures for power and interface cables as described within this manual must be applied. Do not leave cables connected to unused interfaces or disconnected at one end. Changes or modifications to this device not expressly approved by the manufacturer could void the user's authority to operate the equipment.

EMC compliance is, in part, a function of PCB design. Third party add-on AT/XT peripheral PCB assemblies installed within this apparatus may void EMC compliance. FCC/CE compliant PCB assemblies should always be used where possible. Pro-face can accept no responsibility for the EMC performance of this apparatus after system integrator/user installation of PCB assemblies not manufactured and/or expressly tested and approved for compliance by Pro-face. It is the responsibility of the system integrator/user to ensure that installation and operation of such devices does not void EMC compliance.

Table of Contents

CHAPTER 1 – INTRODUCTION	1
PRODUCT OVERVIEW.....	1
STANDARD FEATURES.....	1
OPTIONAL FEATURES.....	3
<i>Front Panels</i>	4
<i>I/O Panel</i>	8
<i>Back Panel</i>	10
<i>Power Panel</i>	11
UNPACKING THE SYSTEM.....	12
QUICK STARTUP.....	12
CHAPTER 2 – INSTALLATION	13
INSTALLATION OVERVIEW.....	13
SYSTEM CUTOUT DIMENSIONS.....	15
4715T , 4715KPM(T).....	15
POWER MANAGEMENT.....	16
<i>System Power</i>	16
<i>Excessive Heat</i>	17
<i>Electrical Noise</i>	17
<i>Line Voltage Variation</i>	17
<i>AC Power Cable</i>	18
INSTALLING INTERNAL HARDWARE OPTIONS.....	19
<i>DRAM and Additional DRAM Dual Inline Memory Modules (DIMMs)</i>	19
<i>PC/AT™ and PCI Boards</i>	19
USING A TOUCH SCREEN.....	20
<i>Installing the Touch Screen Driver</i>	20
<i>Calibrating the Touch Screen</i>	21
CUSTOM LOGO.....	22
CREATING CUSTOM KEYPAD INSERTS.....	22
HAZARDOUS LOCATIONS INSTALLATION.....	25
<i>Safety Agency Approval</i>	25
<i>Definitions</i>	27
<i>Class I Locations</i>	27
<i>Class II Locations</i>	27
<i>Division 1 Locations</i>	27
<i>Division 2 Locations</i>	28
<i>Groups</i>	28
<i>Enclosures</i>	29
<i>Power Switch</i>	29
<i>Cable Connections</i>	29
<i>Communication Cable Interfaces</i>	30
<i>Hazardous Locations Control Drawing</i>	31
<i>Operation and Maintenance</i>	32
CHAPTER 3 – KEYPAD UTILITY PROGRAM	33
LOADING THE KEYPAD UTILITY.....	33
USING THE KEYPAD UTILITY.....	34
STARTUP.....	34
MAIN MENU.....	34
<i>Exit</i>	35

Files Menu.....	35
Macros Menu.....	36
Upload Menu.....	38
Download Menu.....	38
Utilities Menu.....	39
UTILITY BATCH MODE.....	39
KEYPAD SCAN CODES.....	40
CHAPTER 4 – MAINTENANCE.....	43
GENERAL PREVENTIVE MAINTENANCE.....	43
<i>Fuse Replacement</i>	43
<i>Fan Filter Replacement</i>	43
RECOMMENDED HARD DRIVE PREVENTIVE MAINTENANCE.....	44
SYSTEM BATTERY REPLACEMENT.....	45
PRODUCT REPAIR PROGRAM.....	48
FRONT PANEL FRAME.....	49
<i>Chemicals Compatible with 4715T Frame</i>	49
<i>Chemicals Not Compatible with 4715T Frame</i>	49
<i>Chemicals Compatible with all 4715 Frames</i>	50
FRONT PANEL OVERLAY.....	51
<i>Chemicals Compatible with Overlay</i>	51
<i>Compatible Cleaning Agents for Overlay</i>	51
<i>Chemicals Not Compatible with Overlay</i>	51
CHAPTER 5 TROUBLESHOOTING.....	52
DIAGNOSTIC TESTING.....	52
<i>Create Diagnostic Disk</i>	52
<i>Prepare the System</i>	52
RUNNING THE TESTS.....	54
<i>Windows® 2000 Reinstallation</i>	55
<i>Windows XP® Reinstallation</i>	55
INSTALLING DRIVERS.....	56
<i>Video Drivers</i>	56
<i>Video Expansion</i>	56
<i>Touch Screen Drivers</i>	57
<i>Miscellaneous Drivers</i>	57
APPENDIX A – TECHNICAL SPECIFICATIONS.....	58
HARDWARE SPECIFICATIONS.....	58
ENVIRONMENTAL SPECIFICATIONS.....	59
APPENDIX B –BLOCK DIAGRAM AND AIM4 LAYOUT.....	60
AIM4 CPU BOARD LAYOUT.....	60
APPENDIX C – PINOUTS.....	61
KEYBOARD PORT CONNECTOR.....	61
MOUSE PORT CONNECTOR.....	61
FOUR USB CONNECTOR (USB1).....	62
PARALLEL PORT CONNECTOR (LPT1).....	62
SERIAL PORT CONNECTORS.....	63
COM1.....	63
COM2.....	64
COM3.....	64
COM4.....	65

VGA CONNECTOR.....	65
APPENDIX D – AIM4 CONTROLLER JUMPERS.....	66
CLEAR CMOS SETTINGS	66
CPU VOLTAGE SELECT	66
LCD POWER SELECT.....	66
LCD MODE SELECTION.....	66
NOTE: ONLY SPECIFIC LCD PANELS SUPPORT THESE FEATURES.....	66
NORMAL/REVERSE SCAN SELECT.....	67
NOTE: ONLY SPECIFIC LCD PANELS SUPPORT THESE FEATURES.....	67
LCD RESOLUTION.....	67
CRT/LCD SELECT	67
<i>SATA Mode Select</i>	67
IDE1 CONNECTOR - MASTER/SLAVE MODE	67
J5 CONNECTOR – CDROM MASTER/SLAVE MODE	68
IDE1 CONNECTOR – VOLTAGE SELECT.....	68
P2 - COMM 1 CONNECTOR MODE CONFIGURATION	68
COMM CONFIGURATION JUMPER	68
P2 - RS-422/485 TERMINATOR CONFIGURATION	69
P2 - COMM 1 EXTERNAL VOLTAGE SELECT	69
P2 – COMM 1, RS-485 TRANSMIT GATING OPTIONS.....	69
EXTERNAL RESET ENABLE – COMM 3.....	69
APPENDIX E – TSKAM JUMPER & SWITCH SETTINGS.....	70
TSKAM BOARD 1, PART NUMBER 143913-001	70
SW1 – KEYPAD MAPPING	70
H8 PROGRAM MODE	70
APPENDIX F – BACKPLANE JUMPER SETTINGS.....	71

Chapter 1 – Introduction

Product Overview

The 4700 series of flat-panel Industrial PCs combines an Intel® Celeron M® or Pentium® M processor with a flat-panel display to offer a powerful, compact package for the factory floor and other harsh environments. These PCs feature an open architecture to meet a wide variety of applications that require both a powerful PC and a durable industrial enclosure. The system integrates a computer card cage, mass storage, display, and power supply in a reliable industrial form factor.

The 4715T is an Industrial PCs with a touch screen display. The 4715KPM is an Industrial PC with a display, integrated keypad and integrated mouse. The 4715KPMT is an Industrial PC with an integrated keypad, integrated mouse, and touch screen display.

A 4700 system includes:

- A four-slot ISA/PCI backplane, which accommodates
 - Four 9.0” max. expansion cards: three PCI, & one PCI or ISA
- Flat panel display
 - 15” – 1024x768 XGA (TFT)

The front panel of the unit is sealed to NEMA TYPE 4/4X/12 (UL 50) and IP65 (IEC 60529) standards and is protected by an impact-resistant shield.

The processor board combines all the functions of a complete PC/AT compatible computer on a single industrially hardened circuit board. Refer to the AIM4 CPU manual for more information on processor and hardware features.

The system’s modular design allows easy access to expansion boards, switches, power supply, flat-panel display, and disk drives.

Standard Features

The 4700 unit comes standard with the following:

- AIM4 CPU Board
- Four serial COM ports, with three external ports configured as RS-232 and one configurable as either RS-232 or RS-422 or RS-485. The fourth port is an internal header only and defaulted as disabled.
- Parallel port
- VGA port
- SATA HD controller for up to 2 drives

- Intel® Socket 478 Celeron® M or Pentium® M options up to 2.0GHz
- AGP video controller, 4 MB system video RAM, up to 32 MB available
- PCI local-bus IDE controller (for CD/DVD drives and CF options)
- Two 240-pin DDR2 DIMMs that support 256MB, 512 MB, 1GB and 2GB options
- Four USB 2.0 ports, One USB 1.1 port (front panel – keypad units only)
- Two Ethernet ports, One port is an on-board 10/100 BASE T and the other port is 10/100/1000 BASE T
- 400MHz or 533MHZ front side bus depending on the Celeron M or Pentium M processor type
- Flash BIOS
- 6.42" mounting depth (maximum for all 4700 models)
- Flat-panel active color TFT display:
 - 15" (1024x768) on 4715s
- Four AT bus expansion slots
 - Three ¾ length PCI
 - One ¾ length PCI slot or ISA slot
- Side IBM® PS/2® keyboard port and mouse port
- Status LEDs
 - Power
 - Disk
 - COM
 - Input
 - Fault
- CD-ROM, rear access
- Removable SATA 40 GB hard drive(s), rear access
- Compact Flash interface, rear access
- Microsoft Windows XP® operating system (option)
- 100-240 VAC, 50-60 Hz Auto switching AC power supply
- Legacy USB keyboard and mouse support (i.e. PS/2 mouse and keyboard not required)
- Legacy USB floppy, CDROM, and mass storage device support
- All 4700 front panels meet NEMA 4/4X/12 and IP65 specifications when panel-mounted
- UL and cUL Listed for use in Class I and Class II, Division 2 hazardous locations, Groups A, B, C, D, F, and G

Additional standard features 4715KPM(T) models

- 40 relegendable function keys (80 with the F/A function)
- Numeric, PC control, and alpha keypads
- Windows start menu and pop-up menu keys
- Integrated mouse
- Nonincendive front panel USB and PS/2 keyboard/mouse ports

Optional Features

Following are optional available features:

- Touch screen resistive technology
- Higher capacity SATA hard drives and solid state drives
- Various processor speeds
- Preinstalled Microsoft® Windows® 2000, or Windows XP® Professional
- 2.5" Dual SATA Drives
- 9000-USBF, USB floppy (requires Windows 2000, or XP)
- 9000-USBFKA, front access NEMA-sealed USB floppy and keyboard port (requires Windows 98, 2000, or XP)

Front Panels

The 4700 series has a NEMA 4/4X/12 and IP65 sealed front panel. The panel protects the system's interior when the system is properly panel-mounted.

4715T Front Panel

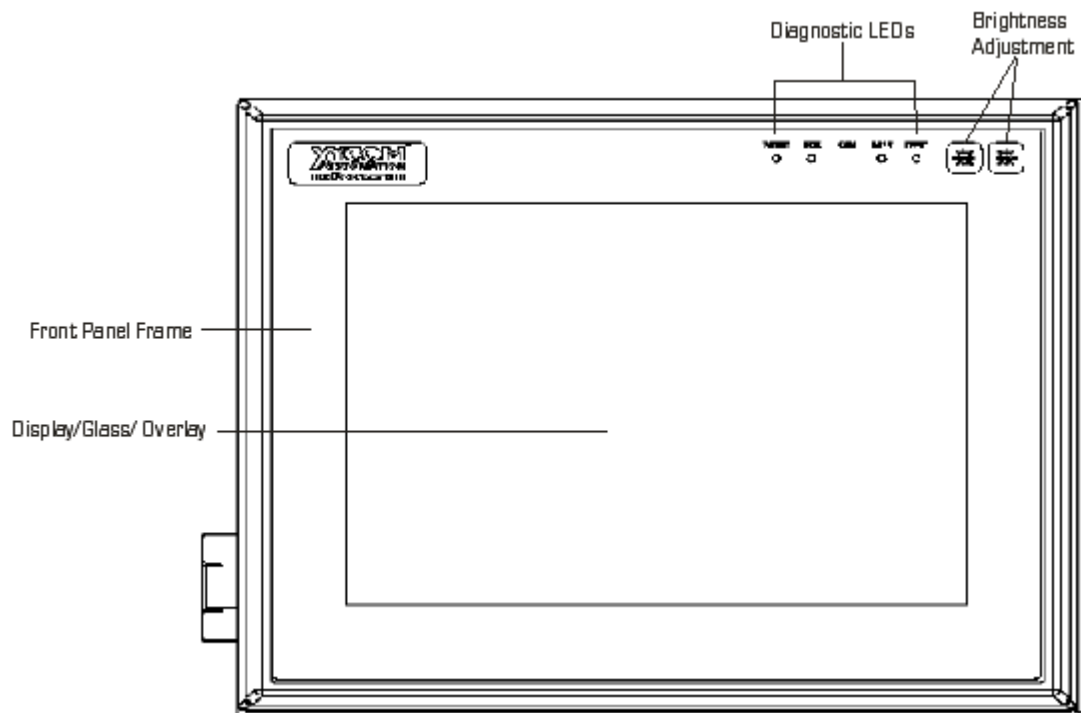

Figure 1-1. 4715T Front Panel

Table 1-1. 4715T Front Panel

Feature	Description
Front Panel	<p>The front panel has four components: a display; strengthened glass covering the display; a frame in which the display and the glass are mounted; and the polyester overlay attached to both the glass and the frame.</p> <p>The 4715T has a 15" TFT LCD flat panel.</p> <p>The strengthened glass covering the display is intended to withstand normal operating conditions. In the event of damage to the glass, the overlay will protect the user from any glass shards.</p> <p>For more information about the frame or the overlay, see Chapter 4 – Maintenance.</p>
Diagnostic LEDs	<p>Following is a description of the LEDs and their meanings:</p> <p>Power GREEN when the system has power.</p> <p>Disk GREEN when the computer is accessing the disk drive.</p> <p>COM GREEN when there is communication activity on one of the serial ports.</p> <p>Input GREEN when the unit has a touch screen (LED gets brighter when a touch input is detected) or a key is pressed.</p> <p>Fault YELLOW when a configuration error exists.</p> <p>During power-up, the BIOS checks the hardware configuration against the configuration stored in the CMOS memory.</p>
Brightness Adjustment	<p>These buttons adjust the brightness of the backlights. The right button increases the brightness and the left button decreases the brightness.</p>

4715KPM(T) Front Panel

Figure 1-2. 4715KPM(T)Front Panel

The 4715KPM(T) features function keys on either side of the flat panel display (PF1-PF20), function keys below the display (F1-F20), a numeric keypad, window keys, a cursor control keypad, diagnostic LEDs, industrial mouse/keyboard and USB ports. All keypad keys are reprogrammable¹, except the F/A key, and all function keys are releasable². See Chapter 3 for more details.

¹ All keypad keys can be programmed to perform any function necessary.

² You are able to create your own, custom keypad inserts to reflect any reprogramming you may have done.

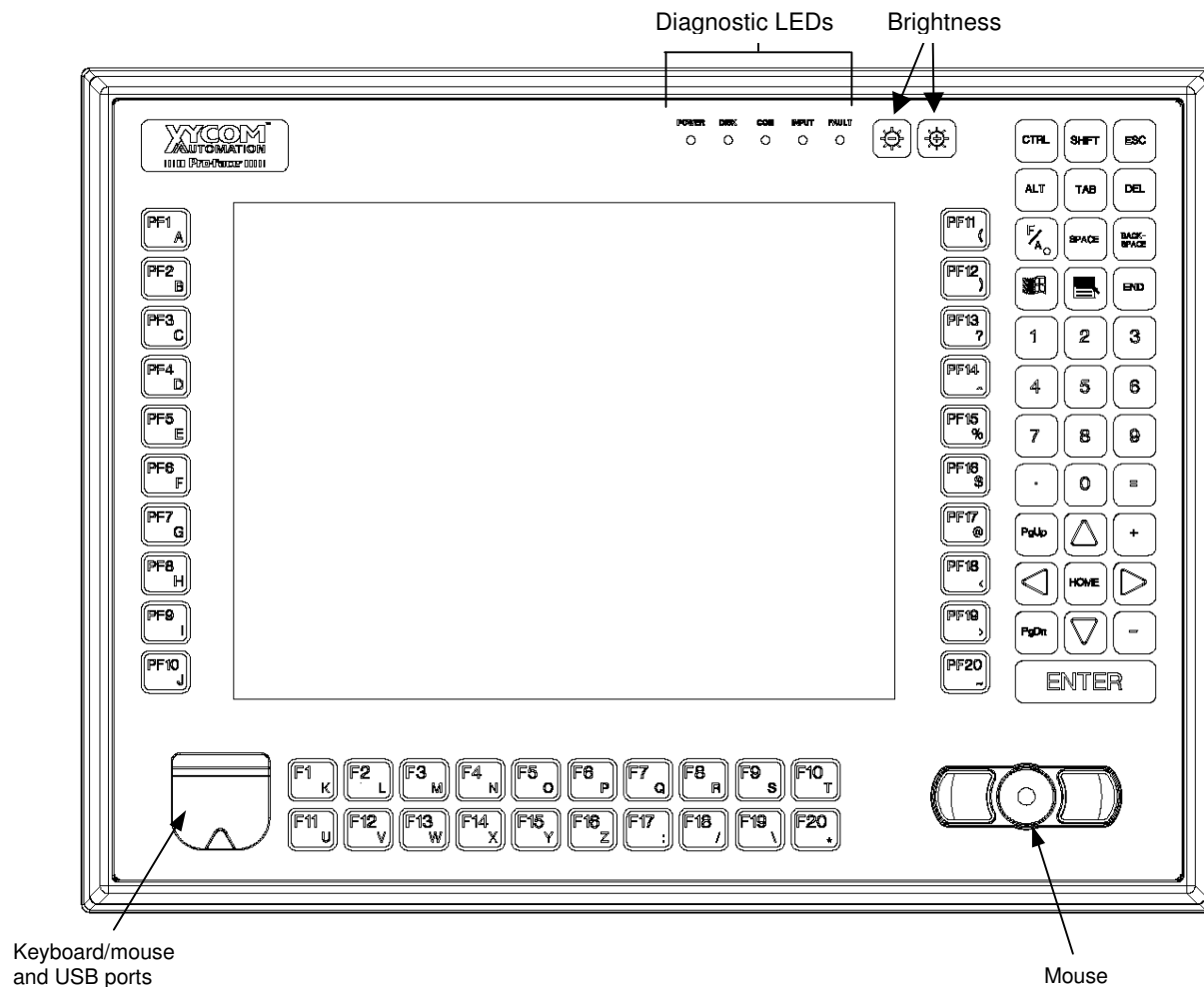
Table 1-2. 4715KPM(T) Front Panel

Feature	Description
Front Panel	<p>The front panel has four components: a display; strengthened glass covering the display; a frame in which the display and the glass are mounted; and the polyester overlay attached to both the glass and the frame.</p> <p>The 4715KPM(T) has a 15" TFT LCD flat panel.</p> <p>The strengthened glass covering the display is intended to withstand normal operating conditions. In the event of damage to the glass, the overlay will protect the user from any glass shards.</p> <p>For more information about the frame or the overlay, see Chapter 4 – Maintenance.</p>
Diagnostic LEDs	<p>Following is a description of the LEDs and their meanings:</p> <p>Power GREEN when the system has power.</p> <p>Disk GREEN when the computer is accessing the disk drive.</p> <p>COM GREEN when there is communication activity on one of the serial ports.</p> <p>Input GREEN when the unit has a touch screen (LED gets brighter when a touch input is detected) or a key is pressed.</p> <p>Fault YELLOW when a configuration error exists.</p> <p>During power-up, the BIOS checks the hardware configuration against the configuration stored in the CMOS memory.</p>
Port Access	<p>The 4715KPM(T) features front panel access to a PS/2 keyboard/mouse port and a USB 1.1 port.</p> <p>These front access connections on the 4715KPM(T) are nonincendive circuits and may be used safely in Class I Division 2, Groups A, B, C, & D and in Class II Division 2, Groups F & G applications. Please refer to the Hazardous Locations control drawing on page 31.</p>
74-Key Keypad	<p>The 4715KPM(T) keypad features:</p> <ul style="list-style-type: none"> • Alpha numeric and control keys • 40 relegendable function keys • All keys re-programmable
Integrated Mouse	<p>The 4715KPM(T) feature a 2-button integrated mouse.</p>
Brightness Adjustment	<p>These buttons adjust the brightness of the backlights. The right button increases the brightness and the left button decreases the brightness.</p>

See Chapter 3, *Keypad Utility*, for detailed instructions on programming the keypad.

Table 1-3. 4715 System I/O Panel

Feature	Description
Parallel Port	The parallel printer port (LPT1) is a DB-25 pin female connector. This port provides a standard PC-compatible printer interface.
COM Ports	COM1, 2 and 3 by default are configured for RS232. COM1 can be reconfigured for RS485 or RS422 with jumpers. For more information, see jumper details in Appendix D.
Keyboard Port	The keyboard port is a PS/2 [®] stacked mini-DIN so a PC/AT keyboard can be attached at the side of the unit. The keyboard port on the side of the unit is the lower connector. Warning: To maintain a safe condition, do not use an external keyboard and/or mouse port when the unit is operating in a hazardous environment.
Mouse Port	The mouse port is a PS/2 stacked mini-DIN that allows you to attach a mouse at the side of the unit. Warning: To maintain a safe condition, do not use an external keyboard and/or mouse port when the unit is operating in a hazardous environment.
Video Port	The video port is a 15-pin D-sub VGA connector at the side of the unit. This connector supports any standard VGA connection. Both the LCD flat panel and video port are active as a default at boot time if video display devices are connected to them.
USB	The Universal Serial Bus (USB) is a four-high connector.
Ethernet Ports	One Ethernet port is an on-board 10/100 BASE T RJ-45 connector with LEDs, and one port is an on-board 10/100/1000 BASE T RJ-45 connector with LEDs.
Removable Compact Flash™ access	This allows external access to Type I or Type II Compact Flash™ for solid state storage media.

Back Panel

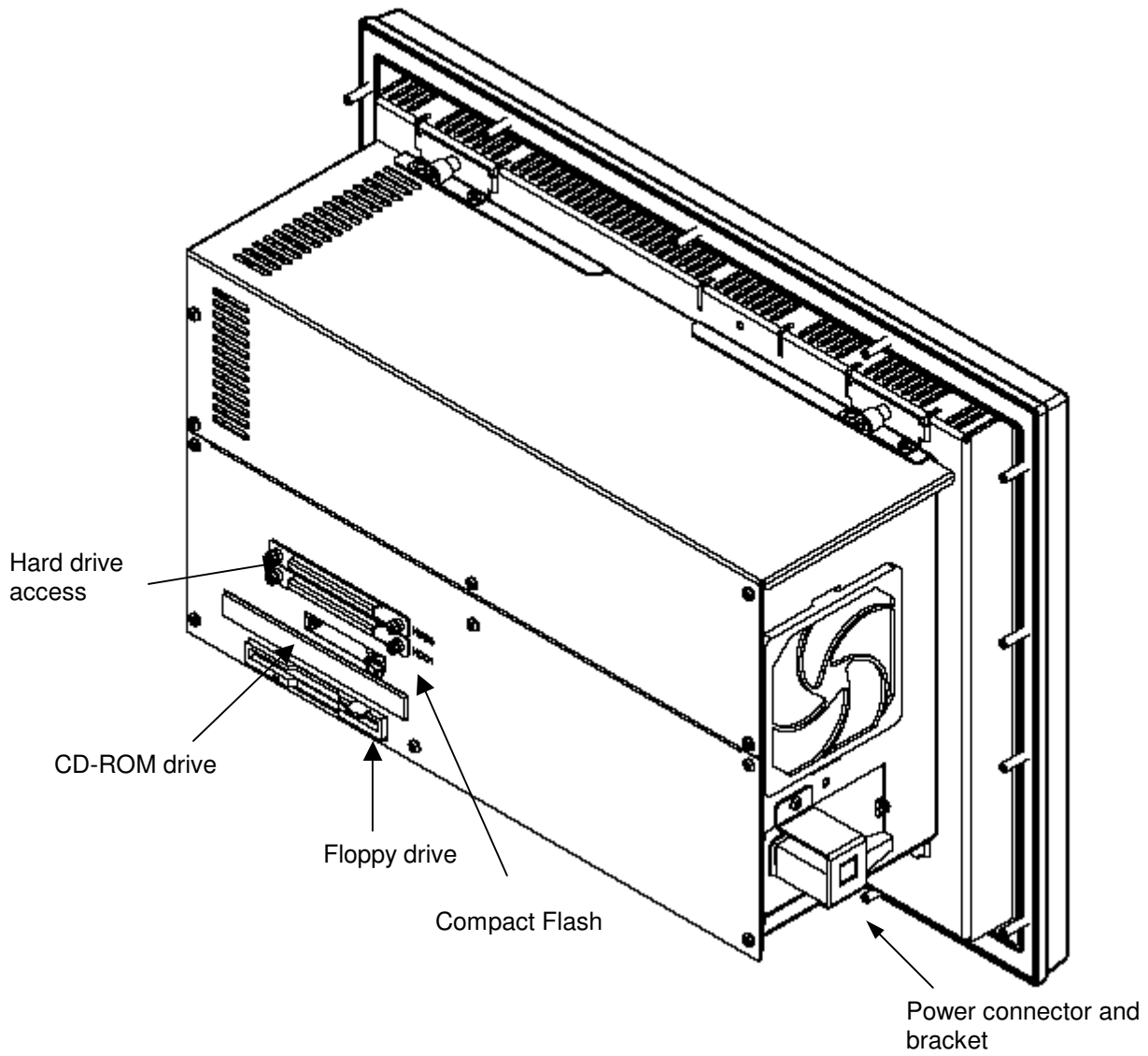

Figure 1-4. 4715 System Back Panel

Power Panel

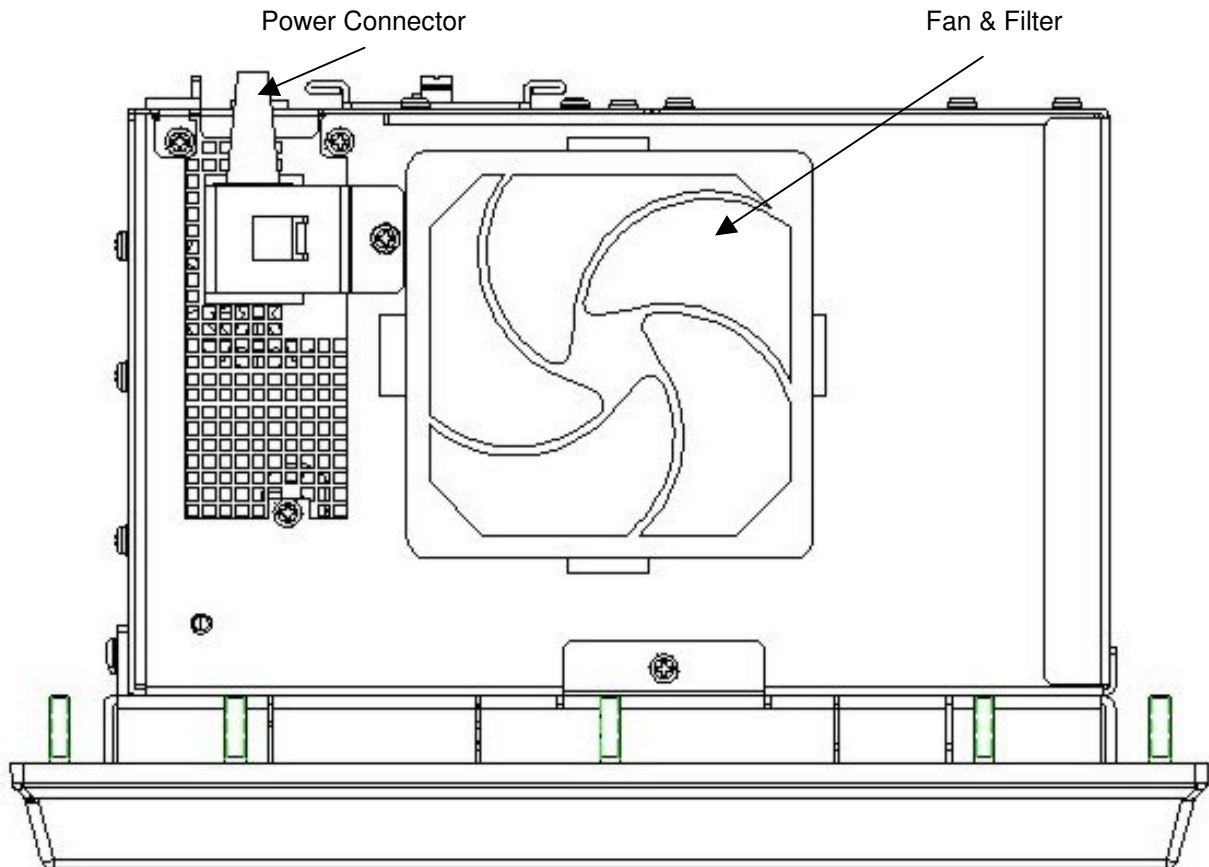

Figure 1-5. 4715 Side Panel with Fan Filter and Power Connector

Table 1-4. 4715 Power Panel

Feature	Description
Power Connector	This is a three-pin connector. Refer to the special <i>Hazardous Locations Installation</i> instructions later in this chapter.
Product ID Label	The product ID label is located on the bottom panel.
Fan and Filter	The filter can be replaced or removed for cleaning. See Chapter 4 for details on the fan filter assembly. Note: Filter should only be replaced with UL94HF-1 rated filters.

Unpacking the System

When you remove the system from its shipping container, verify that you have the parts listed below. Save the box and inner wrapping in the event you need to reship the unit.

- 4715 series computer
- Documentation kit, which includes:
 - Power connector
 - 10-32 hex nuts (for panel mounting with the studs)
 - Cable clamp and screw (for strain-relief of power cord)
 - Documentation and Support Library CD-ROM
 - Operating System Recovery Media or operating system installation disk (CD-ROM)

Quick Startup

This section gives you the steps to get the system up and running without explaining the capabilities and options.

Warning

Remove power from the unit and disconnect the power cord before making any adjustments to the inside or outside of the computer.

Warning

For Hazardous Locations installation, review “Hazardous Locations Installation” in Chapter 2 before startup.

To prepare the system for use, perform the following steps.

1. Attach optional keyboard to the keyboard port.
2. Attach other optional equipment following the instructions in Chapter 2.
3. Attach the power cord from the power receptacle to a properly grounded 100-240 VAC, 50-60 Hz outlet. (See Chapter 2, *Creating an AC Power Cable*.)
4. Turn on power to the unit (via an outlet power switch, if applicable). The system will boot-up into the operating system.
5. Install application software via the CD-ROM, or the network.

Chapter 2 – Installation

This chapter offers detailed installation instructions and outlines the options for the 4700 units. It also includes the guidelines for preparing your unit for installation and use.

Installation Overview

Warning

For Hazardous Locations installation, review the *Hazardous Locations Installation* section in this chapter before startup.

The rugged design of the 4715 unit allows it to be installed in most industrial environments. The system is generally placed in a NEMA 4/4X/12 enclosure to protect against contaminants such as dust, and moisture. Metal enclosures also help minimize the effects of electromagnetic radiation that nearby equipment can generate.

Read the following sections carefully to be sure that you are complying with all the safety requirements.

1. Select a NEMA rated enclosure and place the unit to allow easy access to the system ports (see other sections in this chapter and Appendix A).
 - To assure a NEMA 4 seal, choose an approved enclosure that has a 14-gauge (minimum) (0.075 in/1.9 mm thick steel or 0.125 in/3.2 mm thick aluminum) front face.
 - Be sure to account for the unit's depth when choosing the depth of the enclosure.
2. Create a cutout in the enclosure (Figure 2-1, and in *System Cutout Dimensions*).
 - Be sure to place the unit at a comfortable working level
 - Make sure the area around the cutout is clean and free from metal burrs
3. Mount the unit in an upright position and properly secure the unit into the panel.
 - Tighten the fourteen #10 nuts to 25 inch-pounds (2.8 Newton-meters / 28Kgf cm).
4. Construct a power cable following the instructions in *AC Power Cable* in this chapter.

5. Attach one end of the power cord to the power receptacle on the unit and the other end to a properly grounded 100-240 VAC, 50-60 Hz outlet.
6. Turn on power to the system. The system will boot-up the installed operating system.
7. Install the application software via a floppy drive, CD-ROM, or the network.
8. See Appendixes for jumper configuration considerations, pin-outs, and technical specifications.

Additional aspects to take into account when mounting your 4700 unit:

- Consider locations of accessories such as AC power outlets and lighting (interior illumination and windows) for installation and maintenance convenience
- Prevent condensation by installing a thermostat-controlled heater or air conditioner
- To allow for maximum cooling, avoid obstructing the airflow
- Place any fans or blowers close to the heat generating devices. If using a fan, make sure that outside air is not brought into the enclosure unless a fabric or other reliable filter is used. This filtration prevents conductive particles and other harmful contaminants from entering the enclosure.
- Do not select a location near equipment that generates excessive electromagnetic interference (EMI) or radio frequency interference (RFI). Examples of these types of equipment are: high power welding machines; induction heating equipment; and large motor starters.
- Place incoming power line devices (such as isolation or constant voltage transformers, local power disconnects, and surge suppressers) away from the system. The proper location of incoming line devices keeps power wire runs as short as possible and minimizes electrical noise transmitted to the unit.
- Make sure the location does not exceed the unit's shock, vibration, and temperature specifications
- Install the unit in the rack or panel in such a way as to ensure that it does not cause a hazard from uneven mechanical loading
- Incorporate a readily-accessible disconnect device in the fixed wiring on permanently connected equipment
- Avoid circuit overloading of the supply circuit

System Cutout Dimensions

4715T , 4715KPM(T)

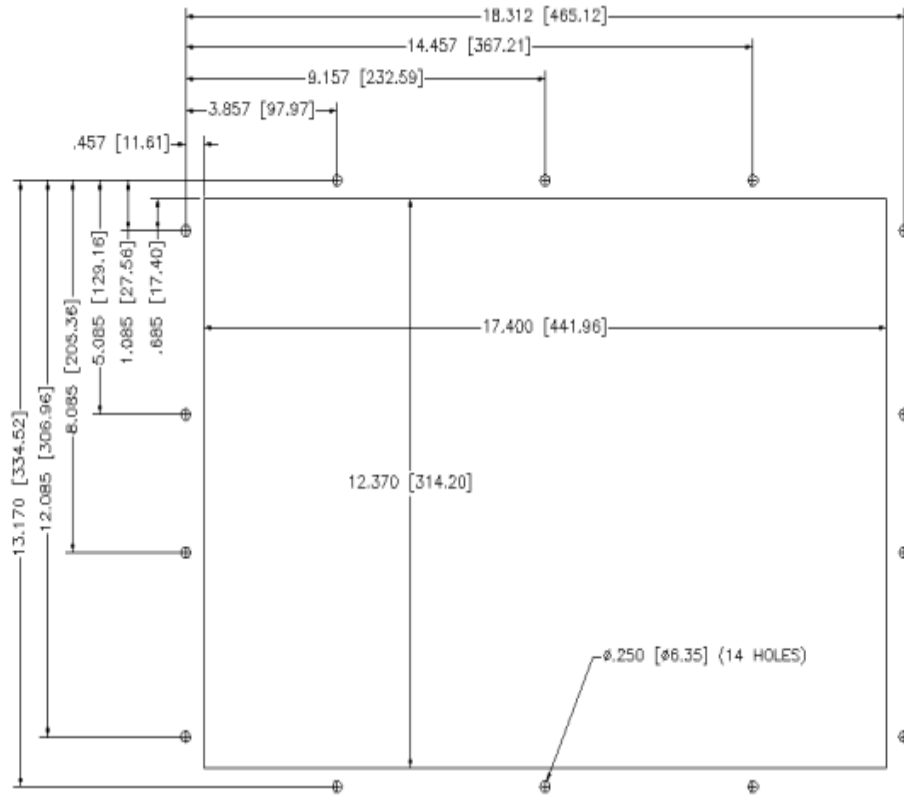

Figure 2-1. 4715T & 4715KPM(T) System Cutout Dimensions (inches [mm])

Power Management

The following paragraphs explain the system power, the power supply, and the effects of excessive heat, electrical noise, and line voltage variation of the 4700 unit.

System Power

Using isolation transformers on the incoming AC power line to the system is always a good practice. An isolation transformer is especially desirable in cases in which heavy equipment is likely to introduce noise onto the AC line.

The isolation transformer can also serve as a step-down transformer to reduce the incoming line voltage to a desired level. The transformer should have a sufficient power rating (units of volt-amperes) to supply the load adequately.

Proper grounding is essential to all safe electrical installations. Refer to the relevant Federal, State/Provincial, and local electric codes, which provide data as to the size and types of conductors, color codes and connections necessary for safe grounding of electrical components. The code specifies that a grounding path must be permanent (no solder), continuous, and able to safely conduct the ground-fault current in the system with minimal impedance (minimum wire required is #18 AWG, 1 mm).

Observe the following practices:

- Separate ground wires (P.E. or Protective Earth) from power wires at the point of entry to the enclosure. To minimize the ground wire length within the enclosure, locate the ground reference point near the point of entry for the plant power supply.
- All electrical racks or chassis and machine elements should be Earth Grounded in installations where high levels of electrical noise can be expected. The rack/chassis should be grounded with a ground rod or attached to nearby Earth structure such as a steel support beam. Each different apparatus should be connected to a single Earth Ground point in a “star” configuration with low impedance cable. Scrape away paint and other non-conductive material from the area where a chassis makes contact with the enclosure.
- In addition to the ground connection made through the mounting bolt or stud, use a one-inch metal braid or size #8 AWG wire to connect between each chassis and the enclosure at the mounting bolt or stud.
-

Power Supply

The power supply on 4715 models provides up to 250 watts of output power throughout the system’s temperature range. The power available for expansion is limited as shown in Table 2-1.

Table 2-1. Available Expansion Current

Voltage	4715 models
+3.3 VDC	4.0A
+5.0 VDC	4.0A
-5.0 VDC	160mA
+12.0 VDC	3.0A
-12.0 VDC	240mA

Excessive Heat

The units withstand temperatures from 0° to 50°C, and are fan-cooled. To keep the temperature in range, the cooling air of the system must not exceed 50°C. Allocate proper spacing between internal components installed in the enclosure.

Electrical Noise

Electrical noise is seldom responsible for damaging components, unless extremely high energy or high voltage levels are present. However, noise can cause temporary malfunctions, which can result in hazardous machine operation in certain applications. Noise may be present only at certain times, may appear at widespread intervals, or in some cases may exist continuously.

Noise commonly enters through input, output, and power supply lines and may also be coupled through the capacitance between these lines and noise signal carrier lines. This usually results from the presence of high voltage or long, close-spaced conductors. When control lines are closely spaced with lines carrying large currents, the coupling of magnetic fields can also occur. Use shielded cables to help minimize noise. Potential noise generators include switching components, relays, solenoids, motors, and motor starters.

Refer to the relevant Federal, State/Provincial, and local electric codes, which provide data such as the size and types of conductors, color codes and connections necessary for safe grounding of electrical components. It is recommended that the high voltage and low voltage cabling be separated and dressed apart. In particular, the AC cables and switch wiring should not be in the same conduit with all communication cables.

Line Voltage Variation

The unit's power supply is built to operate with an input voltage range of 100-240VAC, while still allowing the system to function within its operating margin. As long as the incoming voltage is adequate, the power supply provides all the logic voltages necessary to support the processor, memory, and I/O.

In cases in which the installation is subject to unusual AC line variations, use a constant voltage transformer to prevent the system from shutting down too often. However, a first step toward the solution of the line variations is to correct any possible feed problem in the distribution system. If this correction does not solve the problem, use a constant voltage transformer.

The constant voltage transformer stabilizes the input voltage to the 4700 unit by compensating for voltage changes at the primary in order to maintain a steady voltage at the secondary. When using a constant voltage transformer, check that the power rating is sufficient to supply the unit.

AC Power Cable

A power cable must be created to supply power to the unit. The following materials are needed:

- A three-position power connector (supplied)
- A power cable with three #18 (1.0 mm), #16 (1.3 mm), or #14 (1.6 mm) AWG solid or stranded copper wires, rated 80°C or better

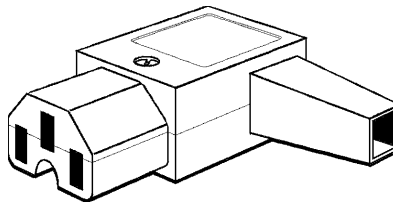

Figure 2-2. 4700 AC Power Connector.

Perform the following steps to construct and attach the cable:

1. Cut wire cable to the desired length.
2. Strip 0.25-inch (6 mm) of insulation from the end of the conductor wire. No bare wire should be exposed when the cable is connected to the workstation.
3. Tin the wire ends with solder if using stranded wire. This will keep the wire from fraying.

Warning

When inserting the wire ends of the power cable into the block plug, be sure there is no exposed wire. Trim the wire ends of the cable or cut a new cable if necessary.

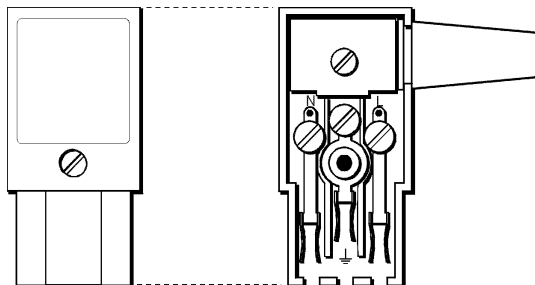

Figure 2-3. Internal View of a 4700 AC Power Connector

4. Insert the three wire ends of the power cable into the hole of the connector plug. Bend the Protective Earth ground (PE) wire, the neutral (N) wire, and the line (L) wire around the corresponding screw. Be sure that no bare wires are exposed.

5. Tighten the three screws above the wires to hold them firmly in place.

Warning

Never tighten the three screws of the block plug when the cable is connected to a power source. The screws are conductive and have full contact with the cable wire.

6. Use the screw provided to secure and strain-relief the power cable inside the connector. Plug the power cable into the power supply located on the side of the unit. Install the plug retainer bracket over the plug (mandatory for Hazardous Location installations).
7. Once the power cable and other optional interface cables are installed, the installation is complete.

Note

When disconnecting the power cord from the unit, be sure to completely loosen the two securing screws on the retainer bracket.

Installing Internal Hardware Options

Remove the top back cover to install internal hardware options.

Caution

Turn off the unit before installing internal hardware.

Warning

Installation of expansion boards may void safety and/or EMC compliance.

DRAM and Additional DRAM Dual Inline Memory Modules (DIMMs)

You can order the 4715 system CPU factory-configured for many configurations of DRAM. The system has two 240-pin DDR2 DIMMs that support 512, 1GB and 2GB options. The maximum amount supported is 2GB. You can reconfigure the DDR2 capacity by changing the DDR2 DIMMs on your board. For more information, refer to the AIM4 CPU manual.

PC/AT™ and PCI Boards

1. Check that the memory and I/O configuration of the board you want to install does not conflict with the CPU and I/O memory maps in your AIM4 CPU board manual.
2. Remove the top back cover.

3. Remove the screw attaching the blank I/O plate to the frame from the desired slot.
4. Slide the PC/AT expansion board into the corresponding rail.
5. Push the board into the backplane connectors.

Caution

DO NOT force the boards or apply uneven pressure.

6. Secure the board by installing the screw through the hole in the board's metal I/O plate and into the top of the track.
7. Replace the top back cover.

Using a Touch Screen

Pro-face/Xycom's touch screen complies with environmental specifications and maintains a NEMA 4 seal when panel-mounted. The touch screen Monitor Mouse driver emulates a Microsoft PS/2 mouse.

Installing the Touch Screen Driver

In order to use the touch screen on your KPMT monitor, you must install the proper driver on the computer hooked to your monitor.

For computers running Windows® 2000, or XP, you will be installing the driver `touchbase_windows.exe`. This driver can be found in the "Drivers\Touchscreen" folder on the Documentation and Support Library CD that shipped with your monitor. The default setting is serial mode.

1. Create a folder named "Touch" on your desktop or in the root directory of your C: drive, and unzip the files into the folder.
2. You will see three folders called Disk1, Disk2, and Disk3. These folders were created so that you can make 3 floppy disks to use for installing the touchscreen driver. If you prefer to install the driver from the Hard Disk then copy the contents from Disk1, Disk2, and Disk3 into a single folder (e.g. Copy Disk2 and Disk3 into Disk1).
3. Select the folder with the driver files in it, then click on the file "setup.exe" and follow the directions. Pro-face suggests that you accept all of the defaults.
4. Calibrate the touchscreen, following the directions in the next section.

Caution

It is recommended that you keep all default setting when installing the driver.

The touch screen drivers are located on the Document and Support Library CD, which is shipped with your unit. Drivers can also be downloaded from <http://www.profaceamerica.com>.

Calibrating the Touch Screen

You need to calibrate the touch screen in the following cases:

- The cursor does not follow the movement of your finger or pen.
- You adjust the size of the video image or change the video mode.

For computers running Windows® 2000, or XP: Before calibrating your touch screen, Pro-face strongly recommends altering the following default settings in the calibration program.

1. Go to START/PROGRAMS/UPDD/SETTINGS
2. Click on the Calibration tab.
3. Set the Calibration points to 25.
4. Set the Margin Percentage to 1.

Note

If the Margin Percentage is set to 0, the calibration may not be correct at the edges of the screen, causing the cursor to jump unexpectedly.

5. Click on the Settings tab.
6. Set the Averaging to 0.
7. Click Apply.

You are now ready to calibrate your touch screen. Follow the instructions found in the following applet to calibrate the touch screen:

START/PROGRAMS/UPDD/CALIBRATE

Note

The touch screen and controller is a matched pair calibrated at the factory. If touch screen and controllers are interchanged calibration may be needed.

Note

When using a PS/2 mouse with the touch screen driver the following applies: Only the Microsoft two button mouse functionality is supported. Extra features on the mouse are not supported and will not function.

Custom Logo

You have the option to place a custom label on the unit. Refer to Figure 2-4 for the dimensions and recommended requirements for a customized label. Once a customized label is procured, place the new label over the “Pro-face/Xycom” label.

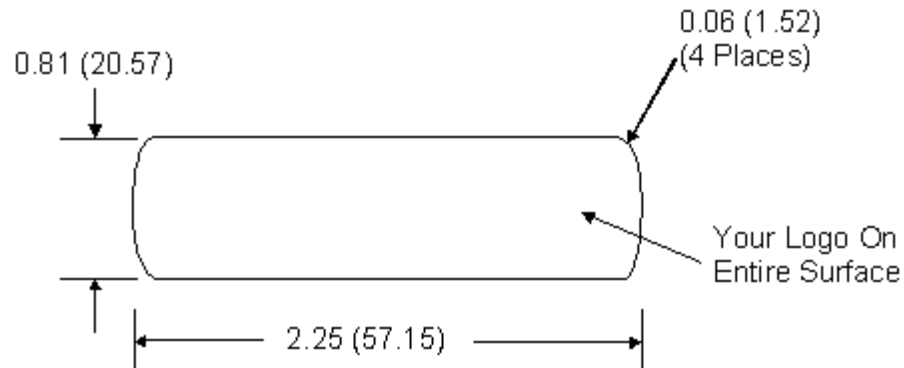

NOTE: All dimensions are in inches (mm)

Recommended material: 0.007 (0.176) thick polyester with 3M #468 adhesive on far side.

Figure 2-4. Logo Label Dimensions

Creating Custom Keypad Inserts

You can customize your keypad with keypad inserts. Refer to Figure 2-5 and Figure 2-6 for insert dimensions and installation for the 4715KPM(T).

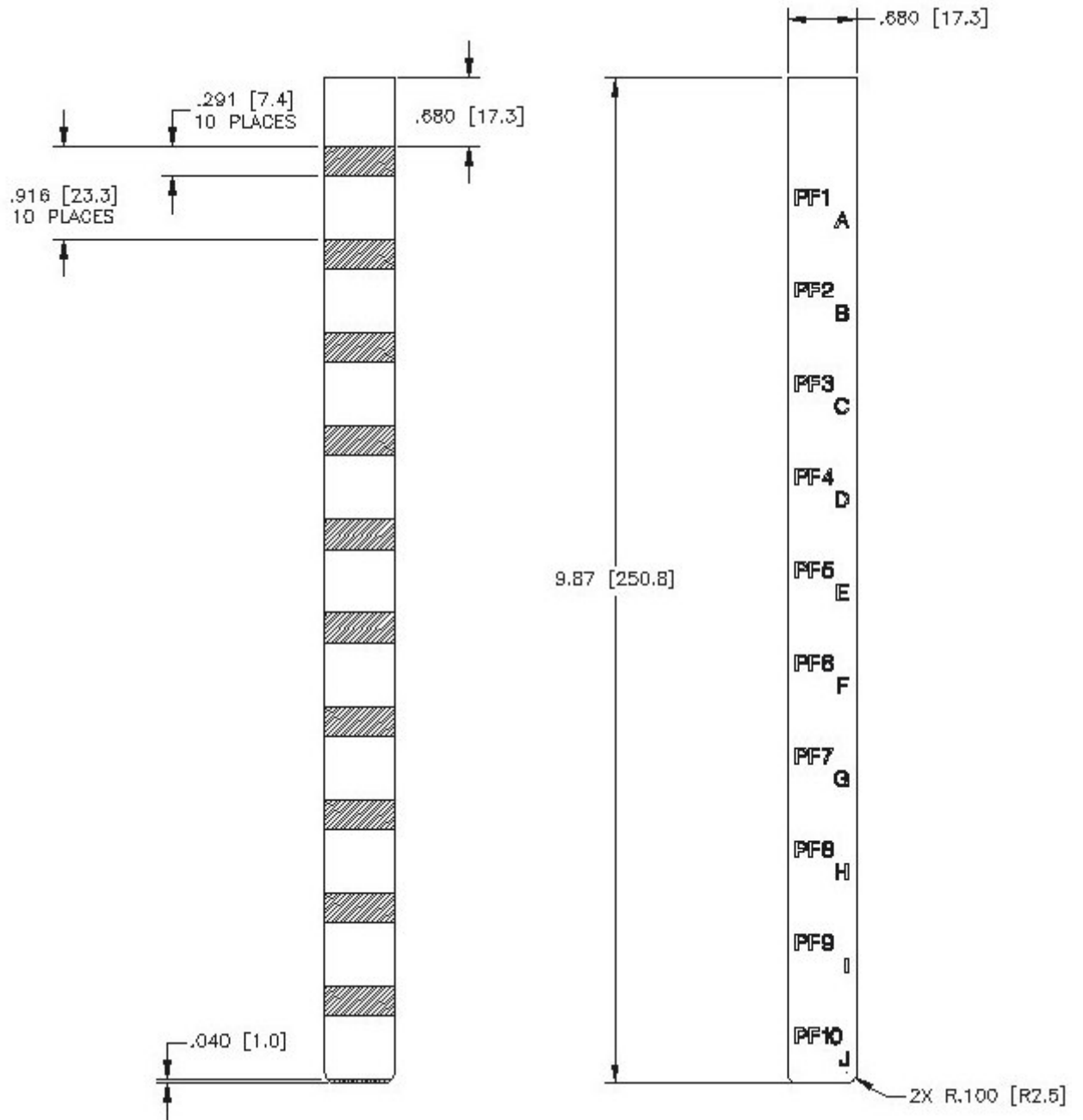
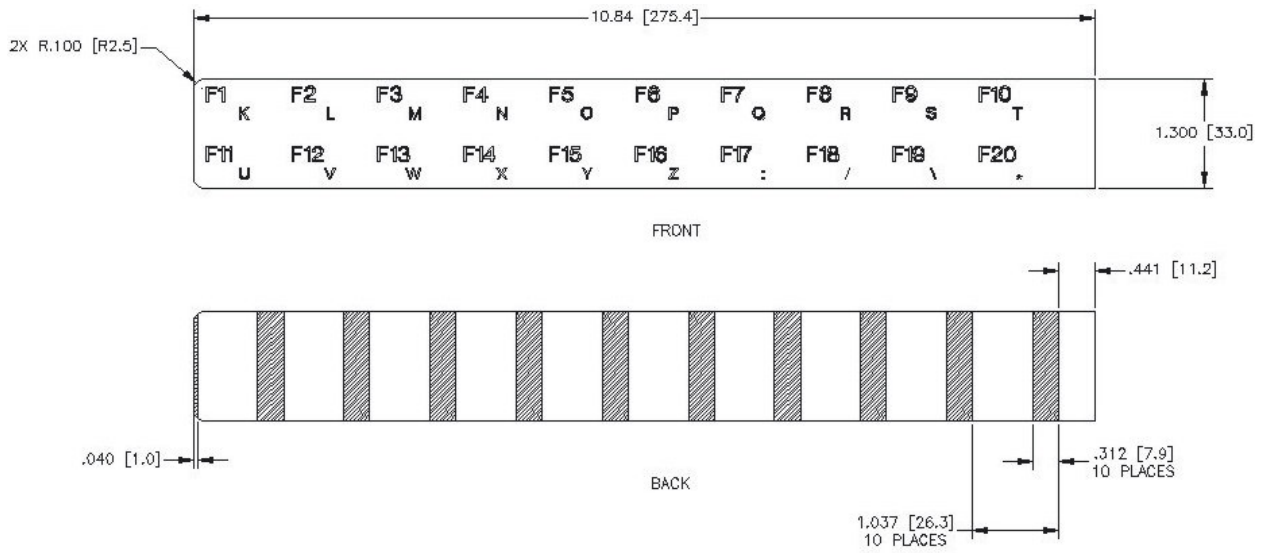

Figure 2-5. 4715KPM(T) Keypad Inserts with Dimensions (PF1 – PF10)

Note: The PF11-PF20 insert has the same dimensions



MATERIAL: .007 [.178] THICK POLYESTER
 ALL DIMENSIONS IN INCHES [mm]

Figure 2-6. 4715 KPM(T) Keypad Insert with Dimensions (F1 - F20)

Hazardous Locations Installation

Pro-face designed the 4715 series to meet the requirements of Class I and II, Division 2 Hazardous Locations applications. Division 2 locations are those locations that are normally non-hazardous, but could become hazardous due to accidents that may expose the area to flammable vapors, gases or combustible dusts.

These systems have been designed as non-incendiary devices. They are not intrinsically safe and should never be operated within a Division 1 (normally hazardous) location when installed as described here. Nor should any peripheral interface device attached to these systems be located within Division 1 locations unless approved and/or certified diode barriers are placed in series with each individual signal and DC power line. Any such installations are beyond the bounds of Pro-face design intent. Pro-face accepts no responsibility for installations of this equipment or any devices attached to this equipment in Division 1 locations.

Note

When additional cards are added, it is the customer's responsibility to ensure that the cards chosen meet operating conditions for Class I and II, Division 2 Hazardous Locations. Additions and/or modifications without express consent from UL and/or Pro-face will void Hazardous Locations compliance.

It is the responsibility of the customer to ensure that the product is properly rated for the location in which it is to be installed. If the intended location does not presently have a Class, Division, and Group rating, then users should consult the appropriate authorities having jurisdiction in order to determine the correct rating for that Hazardous Location.

In accordance with Federal, State/Provincial, and Local regulations, all Hazardous Locations installations should be inspected by the appropriate authority having jurisdiction prior to use. Only technically qualified personnel should install, service, and inspect these systems.

Warning

In order to maintain a safe condition, do not attach an external keyboard or mouse to the rear ports when the unit is operating in a hazardous environment. Refer to the control drawing on page 31 for information on the front USB and keyboard ports.

Safety Agency Approval

The Pro-face systems have the following approvals:

- *Underwriters Laboratories Inc., UL 1604 Standard for Safety.* Electrical equipment for use in Class I and Class II, Division 2, and Class III hazardous (classified) locations. (UL Listed, File E180970)

- *Underwriters Laboratories Inc., UL 508, “Industrial Control Equipment.”* (UL Listed, File E107636)
- *Canadian Standard Association, Specification C22.2 No. 213-M1987.* Non-incendiary electrical equipment for use in Class I, Division 2 hazardous locations. (cUL Listed, File E180970)
- *Canadian Standards Association, Specification C22.2 No. 142,* (cUL Listed, File E107636).

Warning

Suitable for use in Class I, Division 2, Groups A, B, C, and D, and Class II, Division 2, Groups F and G Hazardous Locations or non-hazardous locations only.

Warning – Explosion Hazard

Substitution of components may impair suitability for Class I, Class II, Division 2.

Avertissement – Risque d’Explosion

La substitution de composants peut rendre ce matériel inacceptable pour les emplacements de classe I, II, Division 2.

Warning – Explosion Hazard

Do not disconnect equipment unless the power has been switched off or the area is known to be non-hazardous.

Avertissement – Risque d’Explosion

Avant de déconnecter l’équipement, couper le courant ou s’assurer que l’emplacement est désigné non dangereux.

Warning – Explosion Hazard

When in Hazardous Locations, turn off power before replacing or wiring modules.

Avertissement – Risque d'Explosion

Dans les situations hasardees, couper la courant avant de remplacer ou de cabler les modules.

Definitions

The following Class and Division explanations are derived from Article 500 (Sections 5 and 6) of the United States National Fire Protection Agency National Electric Code (NFPA 70). They are not complete and are included here only for a general description for those not familiar with generic hazardous locations' requirements.

Persons responsible for the installation of this equipment in Hazardous Locations are responsible for ensuring that all relevant codes and regulations related to location rating, enclosure, and wiring are met.

Class I Locations

Class I locations are those in which flammable gases or vapors are or may be present in the air in quantities sufficient to produce explosive or ignitable mixtures.

Class II Locations

Class II locations are those that are, or may become, hazardous because of the presence of combustible dust.

Division 1 Locations

A Division 1 location is one in which flammable or ignitable gasses, vapors, or combustible dusts and particles can exist due the following conditions:

- Normal operating conditions;
- Because of repair, maintenance conditions, leakage, or mechanical failure or abnormal operation of machinery or equipment; or
- Combustible dusts of an electrically conductive nature may be present in hazardous quantities.

Note

Pro-face systems are not suitable for installation within Division 1 locations.

Note

Electrical equipment cannot be installed in Division 1 locations unless they are intrinsically safe, installed inside approved explosion-proof enclosures, or installed inside approved purged and pressurized enclosures.

Division 2 Locations

Division 2 locations are listed below:

- Class I volatile flammable liquids or flammable gasses are handled, processed, or used, but confined within closed containers or closed systems from which they can escape only in cases of accidental rupture or breakdown of such enclosures or systems, or in case of abnormal operation of equipment.
- Ignitable concentrations of Class I vapors or gasses are normally prevented by positive mechanical ventilation, but which may become hazardous due to mechanical failure of those ventilation systems.
- Location is adjacent to a Division 1 location.
- Class II combustible dust is not normally in the air in quantities sufficient to produce explosive or ignitable mixtures. Dust accumulations are normally insufficient to interfere with normal operation of electrical equipment or other apparatus. Combustible dust may be in suspension in the air as a result of the following: malfunctioning of handling or processing equipment; combustible dust accumulations on, or in the vicinity of electrical equipment; may be ignitable by abnormal operation or failure of electrical equipment.

Groups

All electrical equipment that is approved for use in Hazardous Locations must include a group rating. Various flammable and combustible substances are divided into these groups as a function of their individual maximum experimental safe gap (MESG), explosion pressure, and ignition temperature.

Component temperatures and the potential for spark based upon voltage, current, and circuit characteristics, within electrical equipment, will determine what the equipment group rating will be. A device approved for installation within Class I, Group A locations may also be used in Groups B, C, or D.

Note

Approved Class I equipment may not be suitable for Class II installations. Class I includes Groups A, B, C, and D. Class II includes Groups F, and G.

Enclosures

The systems are designed for installation within a clean and dry enclosure for both ordinary and hazardous locations. The front panel meets the requirements of UL and CSA Type 4, 4X, and 12 enclosures. The enclosure used for Class I Hazardous Locations should have a minimum rating of Type 12 (NEMA 12, IP 5X). However, Type 4 (IP 6X) enclosures are strongly recommended.

Panel flatness and rigidity are important if a proper panel seal is to be maintained. If non-metal type enclosures, such as plastic or fiberglass, are to be used, install a rigid metal stiffener behind the front panel. Failure to do so may result in an inadequate panel seal due to flexure of the front panel material between the stud mounts. Tighten the nuts on the mounting studs to 25 inch-pounds.

The requirements for enclosure fittings, conduit, and wiring vary according to the specific rating of the location and the type of flammable or combustible material involved. Those requirements are beyond the scope of this document, and it is the responsibility of the customer to ensure that their installation is compliant with codes and regulations that apply to their specific location. Reference NFPA 70, Article 500 for specific regulations in the United States.

Power Switch

The 4715 series do not have a power switch. The amount of input power required by this system classifies the power switch as an incendiary device because the voltage and current across the make/break device are capable of creating a spark.

Hazardous Locations' regulations require that a power switch rated for ordinary locations may be used if it is located in an area specified as non-hazardous. However, limits in cable length between the workstation and the power switch may apply. Otherwise the switch must be compliant with Class I, Division 1 requirements (intrinsically safe). These switches are built in a manner that prevents the possibility of a spark when contacts are made or broken.

Use suitable UL listed and/or CSA Certified Class I, Division 1 switches in hazardous locations. These switches are available from a wide number of sources. It is the responsibility of the customer to ensure that the power switch selected for their installation has the correct Hazardous Locations rating for the location in which it is installed.

Cable Connections

Division 2 Hazardous Location regulations require that all cable connections be provided with adequate strain-relief and positive interlock. Never connect or disconnect a cable while power is applied at either end of the cable.

Communication Cable Interfaces

All communication cables should include a chassis ground shield. This shield should include both copper braid and aluminum foil. The D-sub style connector housing should be a metal conductive type (e.g., molded zinc) and the ground shield braid should be well terminated directly to the connector housing. Do not use a shield drain wire.

The outer diameter of the cable must be suited to the inner diameter of the cable connector strain-relief in order to ensure that a reliable degree of strain-relief is maintained. Always secure the D-Sub connectors to the workstation mating connectors via the two screws located on both sides.

Warning

Never connect or disconnect the communication cables while power is applied at either end of the cable. This may result in an incendiary spark. Permanent damage to the workstation communication components may occur.

Note

This warning does not apply to the front panel keyboard and USB interface connectors. These connections are nonincendive circuits. Please refer to the Hazardous Locations control drawing on page 31.

Hazardous Locations Control Drawing

Warning
 The following control drawing applies to front panel ports only.

Class I, Division 2, Groups A, B, C and D, and Class II, Division 2, Groups F and G

Hazardous (Classified) Locations.



Notes:

1. Nonincendive Circuit Parameters:

USB Port (Pins 1 to 4)	PS/2 Port (Pins 3 to 4)
$V_{oc} = 5 \text{ VDC}$	$V_{oc} = 5 \text{ VDC}$
$I_{sc} = 3.3\text{A}$	$I_{sc} = 3.3 \text{ A}$
$C_a = 10 \text{ uF}$	$C_a = 10 \text{ uF}$
$L_a = 16 \text{ uH}$	$L_a = 4 \text{ uH}$

2. Selected Nonincendive Field Wiring Apparatus shall satisfy the following:

Nonincendive Field Wiring Apparatus		Pro-face/Xycom Models 4612KPM and KPMT And Models 4715KPM and KPMT
V_{max}	\geq	V_{oc}
I_{max}	\geq	I_{sc}
$C_j + C_{cable}$	\leq	C_a
$L_j + L_{cable}$	\leq	L_a

3. If the electrical parameters of the cable are unknown, the following values may be used:

Capacitance – 60 pF/ft
 Inductive – 0.20 uH/ft

4. Nonincendive Field Wiring must be installed in accordance with Article 501.4(B)(3) of the National Electrical Code ANSI/NFPA 70.

Operation and Maintenance

The systems have been designed for compliance with relevant spark ignition tests. However, please note that the workstation front panel contrast adjustment tactile switches and keyboard connector are the only make/break components intended to be exercised by the operator in the course of normal operation.

Warning

In order to maintain a safe condition, never use an external keyboard or mouse connected to side ports when the unit is operating in the presence of a hazardous environment. Use of the front panel USB or keyboard/mouse ports is safe only if the control drawing criteria is satisfied as indicated on the control drawing on page 31, and if the device is approved for use in the classified Hazardous Location.

With respect to Hazardous Location installations, always observe the following rules:

1. Always install the workstations within an enclosure suitable for the specific application. General-purpose enclosures may be acceptable for Class I applications, but are never acceptable for Class II applications. Type 4 (IP 65) enclosures are recommended even when not required by regulations.
2. If present, keep enclosure doors or openings closed at all times, to avoid the accumulation of foreign matter inside the workstation.
3. Never subject the unit to any installation or service procedures unless power has been removed and the area is known to be non-hazardous. This includes the installation or removal of power cables, communication cables, or removal of the rear cover of the unit.
4. Only technically qualified service personnel should perform all installation and service. These workstations are designed to require no service in the course of normal operation by an operator.

Chapter 3 – Keypad Utility Program

The keypad utility program allows users to redefine any or all of the keypad keys on the unit with new scan codes, using utility software. You must use an external full-stroke PC/AT keyboard to access the utility. This chapter explains how to load the keypad utility, and details how the program's pull-down menus work. Also included in this chapter are the default keypad scan codes.

Note

Your external full-stroke PC/AT keyboard cannot be redefined by running the keypad utility.

Note

The keypad switch arrays are disabled while the keypad utility is running.

Loading the Keypad Utility

Note

Pro-face's keypad utility will only run under DOS 3.2 or better. **The keypad utility will not run in a Windows environment.**

The keypad utility is on the "Documentation and Support Library" CD that shipped with your computer. You will find the self-extracting zip file, *Keypad Utility 1.1 142606-001.exe*, in the folder:

DRIVERS\Keypad Software\Keypad Utility 1.1 142606-001

If your computer is running DOS (revision 3.2 or better), create a subdirectory on your hard drive for the files, and extract the files from the disk into that subdirectory. To run the utility, go to the subdirectory and type *kp3util* at the DOS prompt.

If your computer is not running DOS, you will need to extract the files onto a DOS-bootable diskette. The diskette is then inserted into the floppy drive. You will need to reboot your computer for the computer to access the program. To run the utility, type *kp3util* at the DOS prompt.

Using the Keypad Utility

The keypad utility uses a menu bar and pull-down menu system. All menu bars are displayed across the top of the screen. “Pro-face/Xycom KP3 Utility” and the current menu titles are shown at the bottom of the screen (see Figure 3-1).

A full-stroke keyboard is needed to enter keystrokes while recording a new key macro, editing an existing macro, or entering utility commands. You can redefine all keys on the keypads, except the F/A (Function/Alpha) key. While the utility is running, the keypads are disabled.

Dialog boxes appear for user prompts, and to display error and user advice messages. Any keys used specifically in each menu are shown at the bottom of each screen (see Figure 3-1).

Two keys allow you to exit the menus:

- ESC moves to the previous menu or out of the utility from the Main Menu
- F1 returns to the current menu headings in some of the menus where Exit can be chosen to exit this menu

Startup

To begin using the keypad utility, type *kp3util* at the prompt (for the floppy drive when no DOS is available, or the subdirectory you created earlier). The program will bring up the main menu. Open the *def4612.pkm* file in the main menu to program the keypad. (This file contains the default keypad settings for the 4700 series.) Changes to the default file should be saved to a new file with the *pkm* extension. If you do not open a file, the macros pull-down menu will not be available.

Note

If you make any changes to your keypad and want to set it back to the default settings, open the *pkm* file for your unit (e.g., *def4612.PKM* for 4715KPM) from the File/Open menu, and then download it from the download menu.

Caution

Do not save any changes to the default files.

Main Menu

Table 3-1 shows the Main Menu screen. The functions of the pull-down menus are described in the following sections.

Note

Exit and Download do not have pull-down menus.

Note

Use F1 to access the menu bar options in the *kp3util* program.

Exit	Files	Macros	Upload	Download	Utilities
	Open	Function Keys	KP Ctl. Version		Factory Default
	Close	Alpha Keys	Exit		Exit
	Save				
	Save As				
	Delete				
	Exit				
<Company Name> KP3 Utility: MAIN			L-Arrow, R-Arrow, Enter		

Figure 3-1. Main Menu, showing first-level pull-down menus

Exit

Exit closes any open files and exits the utility. ESC can also be used for this purpose. ESC works for exiting the other menus as well.

Files Menu

When you choose Files, a pull-down menu will display the following choices: Open, Close, Save, Save As, Delete, and Exit. The following table describes these menu commands.

Table 3-1. Files Menu

Command	Description
Open	Opens a file that contains a macro set for the keypad and loads the contents into memory. Any macro set in memory is overwritten. Once loaded, the macro set is available to edit, view, teach, or download to the keyboard controller.
Close	Clears the macro set from memory and closes the file from which the set came.
Save	Copies the macro set from memory back into its original file. The original file contents are overwritten.
Save As	Creates a new file under the specified name and copies the macro set from memory into it. For example, to define different sets of codes, save each set under a different name and download the one you wish to use.
Delete	Deletes a file.
Exit	Returns to the Main Menu.

You can save files containing keypad macro sets (a macro for each key) on disk, and then load them into memory to view, edit, teach, or download to the keyboard controller. Some of these files may be included in the utility package for use in reconfiguring the keypads for different software packages, and as templates for defining completely new keypad macro sets.

Macros Menu

Note

You must have a macro file in memory before the Macros Menu is available. To load a macro file, select the File/Open menu.

When you select Macros, a keypad type pull-down menu is available. This pull-down menu provides the following choices: Function Keys, Alpha Keys, and Exit. Table 3-2 explains the commands in the Macros Keypad Type menu.

Table 3-2. Macros Keypad Type Menu

Command	Description
Function Keys	Selects the function keys on the keypad to view, edit, or teach.
Alpha Keys	Selects the alpha keys on the keypad to view, edit, or teach.
Exit	Returns to the main menu.

After choosing which keys you want to work with (Function or Alpha), another pull-down menu becomes available. This macros edit menu displays the following choices: Exit, View, Teach, and Edit. Table 3-3 explains the commands in the Macros Edit menu.

Table 3-3. Macros Edit Menu

Command	Description
Exit	Returns to the Main Menu.
View	<p>Lets you view, but not edit, the macro for the selected key. When View is chosen, the Exit option is displayed on the menu bar and a graphic representation of the chosen keypad is shown. To return to the Macros Menu, select Exit from the View Menu.</p> <p>To select a key to view, use the arrow keys to position the cursor on the desired key and press ENTER. The macro is displayed as two lines: ASCII and code. The ASCII line displays each keycode as the keys it represents on the full-stroke keyboard. Special labels are used for certain keys (e.g., Spc for space bar, UAr for up arrow, and bk for the break code prefix). The code line is displayed in either Hex or decimal. There is a one-to-one correspondence between the ASCII and code lines.</p> <p>While viewing the macro, the menu bar displays two options: Exit and Hex/Decimal. To access the menu bar, use F1. Exit returns to the View Menu; Hex/Decimal toggles between displaying the macro in hex or decimal format. When Hex is chosen, the keycodes are displayed as hexadecimal value scan codes. When Decimal is chosen, the keycodes are displayed as the decimal equivalent of the hex codes.</p> <p>For example, the macro <i>abc</i> would be displayed as 1C F0 1C 32 F0 32 21 F0 21 in</p>

Table 3-3. Macros Edit Menu

Command	Description
	hex, and 28 240 28 50 240 50 33 240 33 in decimal.
Teach	<p>Allows you to record up to 105 keystrokes in a macro. When Teach is selected, a graphic representation of the keypad currently in memory displays. Menu bar choices are Exit, ASCII, and Click OFF. To access the menu bar, use F1.</p> <p>As usual, Exit returns you to the Macros menu. ASCII specifies the format to display the keystrokes as they are entered. ASCII is the default setting. The Click OFF choice is not supported.</p> <p>To select a key to define, use the arrow keys to position the cursor on the desired key and press ENTER. After you select a key, the utility records every keystroke made on the external full-stroke keyboard. The keystrokes are saved in a macro assigned to the chosen key. As the keystrokes are entered, they are displayed using the chosen format.</p> <p>ESC stops recording and returns you to the Teach Menu, so you cannot record the ESC key. However, ESC can be included in a macro by using the editor.</p> <p>Changes made to the macros in the Teach Menu are not programmed until you select Download.</p>
Edit	<p>Displays a graphic representation of the keypad in memory and a menu bar displaying Exit and Click OFF. Exit returns to the Macros menu. Click OFF is not supported.</p> <p>To select a key to edit, use the arrow keys to position the cursor on the desired key and press ENTER. In edit mode, the macro is displayed as two lines. The top line displays the macro in either hex or decimal format, and is the line in which the editing takes place. The bottom line displays the macro in ASCII format; this line is not user configurable. The bottom line keeps track of which part of the macro being edited, and is updated by the utility as editing takes place. The insert, delete, and cursor control keys on the full-stroke keyboard are active for editing.</p> <p>When a key is selected from the Edit Macro option, the menu bar displays the following choices: Exit, Cut, Copy, Paste, Codes, Hex, and I/O (Insert/Overtyping). The macro for the chosen key is also displayed. To access the menu bar, use F1. Use the Insert key on your full-stroke external keyboard to toggle between insert and overtype mode.</p>
Edit/Cut	<p>Cut deletes a sequence of scan codes from the macro. To select a section to cut:</p> <ol style="list-style-type: none"> 1. Place the cursor on the first character to cut. 2. Press F1 (to access the menu bar choices) and select CUT. 3. Press ENTER. Cut should still be highlighted, but the cursor will appear on the Edit line. Move the cursor to the last character to cut and press ENTER. <p>The last character of every macro is the end of the macro (EOM) and cannot be deleted.</p>
Edit/Copy	<p>Copy duplicates a sequence of scan codes from the macro into memory. To select the section to copy:</p> <ol style="list-style-type: none"> 1. Place the cursor on the first character to copy. Press F1 and select Copy. 2. Press ENTER. Copy should still be highlighted, but the cursor will appear on the Edit line. 3. Move the cursor to the last character to copy and press ENTER. <p>The copied item does not appear on the screen until you select Paste.</p>

Table 3-3. Macros Edit Menu

Command	Description
Edit/Paste	<p>Paste inserts a sequence of scan codes (which were saved in memory using Copy) into the macro. To paste a sequence of scan codes that were previously copied, position the cursor where you want the text to appear and then press F1. Select Paste and then press ENTER.</p> <p>Codes displays a table of keys and their scan codes in Hex. See the Codes section in this chapter for a complete code listing.</p> <p>Hex/Decimal toggles between displaying the scan codes in Hex and Decimal formats.</p> <p>I/O allows the user to insert text or type over text in the code(s). Use the Insert key on your full-stroke external keyboard to toggle between insert and overtype mode.</p>

Note

The 4715KPMT do not support the programming of special functions such as caps lock, Number lock, or scroll lock.

Upload Menu

Use the Upload Menu to access the keypad version. As illustrated in Table 3-4, the choices in this menu are Keypad Version and Exit.

Table 3-4. Upload Menu

Command	Description
Keypad Version	Commands the keyboard controller to send its firmware revision number.
Exit	Returns to the Main Menu.

Download Menu

Note

Download contains no options. If you select Download, any macro set previously programmed is overwritten.

Caution

The macros set in memory should be saved before downloading. If the set is not saved, all changes will be lost.

Download should be used only after all the keypad keys have been programmed and saved to a *.pkm file. Selecting Download prior to saving changes will result in a loss of all keypad macro programming.

When you select Download, the program creates a download file called *download.dld* and loads the keypad controller's non-volatile memory with the new

macros, which become the new key definitions for the keypad. After the download is complete, the system will prompt the user to cycle power.

Utilities Menu

When the Utilities menu is selected, two choices are displayed: Factory Default, and Exit. Table 3-5 explains these choices.

Table 3-5. Utilities Menu

Command	Description
Factory Default	Reprograms the keypad macros to the factory default settings. After completion, the system will need to be power cycled.
Exit	Returns to the Main Menu.

Utility Batch Mode

The Utility Batch Mode can be used to reprogram keypads on multiple units with the same customized keypad macros. This feature is useful because it allows you to do the reprogramming without having to enter the full keypad utility for each individual unit. After you have programmed the first keypad macros, you will need to create a DOS-bootable diskette to run the Utility Batch Mode.

You will need to extract files from the Documentation and Support Library CD-ROM to for the diskette. The necessary files can be found in the folder,

DRIVERS\Keypad Software\Keypad Utility 1.1 142606-001

Save the following files from the CD-ROM to the root directory on your DOS-bootable diskette:

- H8flash.exe
- KP3util.exe
- H8fload.mot
- *.pkm
- codes.pkm
- symbols.pkm
- download.dld

Then, insert the diskette into the unit you want to reprogram and reboot it. At the DOS prompt, type the *kp3util *.pkm* to run the reprogramming function. This utility can be used on as many units as necessary.

Note

The *.pkm file is the macro file you saved in the earlier step. The * indicates the name you selected for the file.

Note

The *download.dld* file was created after the last keypad programming process. This includes both new programming and reprogramming the keypad to the factory default settings.

Keypad Scan Codes

The utility's default keypad keycodes are listed in the following table.

Table 3-6. Default Keypad Keycodes

4715KPM(T) Description of Key	F/A Key LED Off (Function Mode)			F/A Key LED On (Alpha Mode)		
	Keyboard Equivalent	Make Codes	Break Codes	Keyboard Equivalent	Make Codes	Break Codes
PF1 / A	F21	14 05	F0 05 F0 14	A	1C	F0 1C
PF2 / B	F22	14 06	F0 06 F0 14	B	32	F0 32
PF3 / C	F23	14 04	F0 04 F0 14	C	21	F0 21
PF4 / D	F24	14 0C	F0 0C F0 14	D	23	F0 23
PF5 / E	F25	14 03	F0 03 F0 14	E	24	F0 24
PF6 / F	F26	14 0B	F0 0B F0 14	F	2B	F0 2B
PF7 / G	F27	14 83	F0 83 F0 14	G	34	F0 34
PF8 / H	F28	14 0A	F0 0A F0 14	H	33	F0 33
PF9 / I	F29	14 01	F0 01 F0 14	I	43	F0 43
PF10 / J	F30	14 09	F0 09 F0 14	J	3B	F0 3B
F1 / K	F1	05	F0 05	K	42	F0 42
F2 / L	F2	06	F0 06	L	4B	F0 4B
F3 / M	F3	04	F0 04	M	3A	F0 3A
F4 / N	F4	0C	F0 0C	N	31	F0 31
F5 / O	F5	03	F0 03	O	44	F0 44
F6 / P	F6	0B	F0 0B	P	4D	F0 4D
F7 / Q	F7	83	F0 83	Q	15	F0 15
F8 / R	F8	0A	F0 0A	R	2D	F0 2D
F9 / S	F9	01	F0 01	S	1B	F0 1B
F10 / T	F10	09	F0 09	T	2C	F0 2C
F11 / U	F11	12 05	F0 05 F0 12	U	3C	F0 3C
F12 / V	F12	12 06	F0 06 F0 12	V	2A	F0 2A
F13 / W	F13	12 04	F0 04 F0 12	W	1D	F0 1D
F14 / X	F14	12 0C	F0 0C F0 12	X	22	F0 22
F15 / Y	F15	12 03	F0 03 F0 12	Y	35	F0 35
F16 / Z	F16	12 0B	F0 0B F0 12	Z	1A	F0 1A
F17 / :	F17	12 83	F0 83 F0 12	:	12 4C	F0 12 F0 4C
F18 / /	F18	12 0A	F0 0A F0 12	/	4A	F0 4A
F19 / \	F19	12 01	F0 01 F0 12	\	5D	F0 5D
F20 / *	F20	12 09	F0 09 F0 12	*	12 3E	F0 12 F0 3E
PF11 / (F31	11 05	F0 05 F0 11	(12 46	F0 12 F0 46

Table 3-6. Default Keypad Keycodes

4715KPM(T)	F/A Key LED Off (Function Mode)			F/A Key LED On (Alpha Mode)		
Description of Key	Keyboard Equivalent	Make Codes	Break Codes	Keyboard Equivalent	Make Codes	Break Codes
PF12 /)	F32	11 06	F0 06 F0 11)	12 45	F0 12 F0 45
PF13 / ?	F33	11 04	F0 04 F0 11	?	12 4A	F0 12 F0 4A
PF14 / ^	F34	11 0C	F0 0C F0 11	^	12 36	F0 12 F0 36
PF15 / %	F35	11 03	F0 03 F0 11	%	12 2E	F0 12 F0 2E
PF16 / \$	F36	11 0B	F0 0B F0 11	\$	12 25	F0 12 F0 25
PF17 / @	F37	11 83	F0 83 F0 11	@	12 1E	F0 12 F0 1E
PF18 / <	F38	11 0A	F0 0A F0 11	<	12 41	F0 12 F0 41
PF19 / >	F39	11 01	F0 01 F0 11	>	12 49	F0 12 F0 49
PF20 / ~	F40	11 09	F0 09 F0 11	~	12 0E	F0 12 F0 0E
CTRL	CTRL ¹	14	F0 14	CTRL	14	F0 14
SHIFT	SHIFT ¹	12	F0 12	SHIFT	12	F0 12
ESC	ESC	76	F0 76	ESC	76	F0 76
ALT	ALT ¹	11	F0 11	ALT	11	F0 11
TAB	TAB	0D	F0 0D	TAB	0D	F0 0D
DEL	DEL	E0 12 E0 71	E0 F0 71 E0 F0 12	DEL	E0 12 E0 71	E0 F0 71 E0 F0 12
F/A						
SPACE	SPACE	29	F0 29	SPACE	29	F0 29
BACKSPACE	BACKSPAC E	66	F0 66	BACKSPAC E	66	F0 66
1	1	16	F0 16	1	16	F0 16
2	2	1E	F0 1E	2	1E	F0 1E
3	3	26	F0 26	3	26	F0 26
4	4	25	F0 25	4	25	F0 25
5	5	2E	F0 2E	5	2E	F0 2E
6	6	36	F0 36	6	36	F0 36
7	7	3D	F0 3D	7	3D	F0 3D
8	8	3E	F0 3E	8	3E	F0 3E
9	9	46	F0 46	9	46	F0 46
.	.	49	F0 49	.	49	F0 49
0	0	45	F0 45	0	45	F0 45
=	=	55	F0 55	=	55	F0 55
PgUp	PgUp	E0 12 E0 7D	E0 F0 7D E0 F0 12	PgUp	E0 12 E0 7D	E0 F0 7D E0 F0 12
up arr	up arr	E0 12 E0 75	E0 F0 75 E0 F0 12	up arr	E0 12 E0 75	E0 F0 75 E0 F0 12
+	+ ²	79	F0 79	+	79	F0 79
left arr	left arr	E0 12 E0 6B	E0 F0 6B E0 F0 12	left arr	E0 12 E0 6B	E0 F0 6B E0 F0 12
HOME	HOME	E0 12 E0 6C	E0 F0 6C E0 F0 12	HOME	E0 12 E0 6C	E0 F0 6C E0 F0 12
right arr	right arr	E0 12 E0 74	E0 F0 74 E0 F0 12	right arr	E0 12 E0 74	E0 F0 74 E0 F0 12
PgDn	PgDn	E0 12 E0 7A	E0 F0 7A E0 F0 12	PgDn	E0 12 E0 7A	E0 F0 7A E0 F0 12
down arr	down arr	E0 12 E0 72	E0 F0 72 E0 F0 12	down arr	E0 12 E0 72	E0 F0 72 E0 F0 12
-	- ²	7B	F0 7B	-	7B	F0 7B
ENTER	ENTER ¹	5A	F0 5A	ENTER	5A	F0 5A
END	END	E0 12 E0 69	E0 F0 69 E0 F0 12	END	E0 12 E0 69	E0 F0 69 E0 F0 12

Table 3-6. Default Keypad Keycodes

4715KPM(T)	F/A Key LED Off (Function Mode)			F/A Key LED On (Alpha Mode)		
	Description of Key	Keyboard Equivalent	Make Codes	Break Codes	Keyboard Equivalent	Make Codes
Left Start	Mouse click (windows start menu)	E0 12 E0 1F	E0 F0 1F E0 F0 12		E0 12 E0 1F	E0 F0 1F E0 F0 12
Explorer	Mouse click (windows pop-up menu)	E0 12 E0 2F	E0 F0 2F E0 F0 12		E0 12 E0 2F	E0 F0 2F E0 F0 12

¹: Use the keyboard buttons located on the left side of the keyboard, i.e. the buttons normally used with the alpha keys

²: Use the keyboard buttons located on the right side of the keyboard, i.e. the buttons normally used with the numeric keys

NOTES:

- F11-F20 = SHIFT F1-F10
- F21-F30 = CTRL F1-F10
- F31-F40 = ALT F1-F10
- END, LEFT START, and EXPLORE keys are available.

Chapter 4 – Maintenance

The 4715 series is designed to withstand the harsh environment of the factory floor. Routine maintenance can help keep your system in good operating condition. Preventive maintenance consists of several basic procedures that will greatly reduce the chance of system malfunction. Schedule preventive maintenance along with the regular equipment maintenance to minimize down time.

General Preventive Maintenance

Here are some preventive measures you can take:

- Clean the display screen using a non-residue cleaner such as a mild window cleaning solution or CRT screen cleaner. Take care not to scratch the screen face.
- *Clean or change the fan filter periodically* to ensure that the air circulating in the unit is clean. Wash the filter with warm water and dish soap, and let it air dry. Do not scrub the filter, and do not reinstall it into the unit until it is completely dry.
- *Base your maintenance schedule* on the type of environment the system is in (i.e., if the area is dusty, you should schedule maintenance more often than if it is a dry, clean area). Check the filter often to determine if it needs to be changed ahead of schedule.
- *Remove dust and dirt from PC components.* If dust builds up on heat sinks and circuitry, an obstruction of heat dissipation could cause the unit to malfunction. If dust reaches the electronic boards, a short circuit could occur.
- *Check the connections to I/O modules,* especially in environments where vibration could loosen the connections. Check to see that all plugs, sockets, terminal strips, and module connections are solid.
- *Remove unnecessary articles, such as drawings or manuals, from the unit.* They can obstruct airflow and create hot spots, which cause the system to malfunction.
- *Do not place noise-generating equipment near the 4700 unit.*

Fuse Replacement

The 4715 unit has no accessible fuse. Return the unit to the factory for fuse replacement.

Fan Filter Replacement

To change the fan filter, remove the grill and filter as illustrated in Figure 4–1 and replace the filter. Then snap the assembly back into position. **Note:** Filter should only be replaced with UL94HF-1 rated filters.

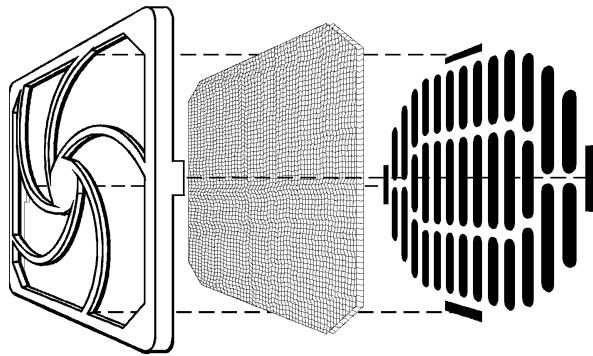

Figure 4-1. Fan Assembly

Caution

Do not operate the 4715 without a fan filter. Dust build-up could cause the unit to malfunction.

Recommended Hard Drive Preventive Maintenance

Pro-face has recognized that hard drive failures may begin to increase an average of four to five years into the life of most computers used in industrial applications. Therefore, it is our recommendation as a preventive maintenance measure that all hard drives used in these types of applications be replaced at a two year interval to avoid any down time related to hard drive failure.

Pro-face believes it is important to keep our customers informed, to offer alternative solutions, and to provide all of our customers with the excellent service they deserve.

Any questions regarding this issue may be directed to our support center at support@profaceamerica.com.

Note

Pro-face recommends frequent backups of your hard drive, especially before beginning preventive maintenance procedures.

System Battery Replacement

The 4715 series AIM4 CPU board includes a coin cell type lithium battery that maintains computer configuration, date, and time information when input power is removed from the system.

If the AIM4 CPU board battery life is ended then the 4715 series computer will no longer maintain the configuration information, date, or time and the battery will need to be replaced. In this case, the following types of error messages will be displayed on the screen at start-up time:

```
ERROR
0271: Check Date and Time Settings
Warning
0251: System CMOS Checksum Bad - Default Configuration
Used

Press <F1> to Resume, <F2> to Setup
```

BATTERY SPECIFICATIONS:

Part Number: CR2032
Voltage: 3 V
Nominal Capacity: 220 mAh

This battery must be a UL Recognized component.

BATTERY LIFETIME:

Battery current is not consumed while input power is applied to the AIM4 CPU board. However, electrolyte loss through the crimp seal will typically occur at the rate of approximately 0.5% per year at 20 degrees C (68 F). This rate will increase with higher temperatures.

The AIM4 CPU board will consume approximately 6 uA of battery current when power is removed from the motherboard. At this rate, the battery will last approximately 4.2 years in storage at 21 degrees C (70 F). This represents 100% duty cycle, or 'input power off time'. Example:

Battery Capacity = 220 mAh

IC Current Drain = 6 uA

Battery lifetime = $(0.22 \text{ aH}) / 6 \times 10^{-6} = 36,666 \text{ hours} = 4.2 \text{ years}$.

When input power is off at the rate of 12 hours per day continuously the battery life should be approximately double the 100% duty cycle time, or 8.4 years at 21 degrees C (50% duty cycle). When input power is off at the rate of 16 hours per day the lifetime should be approximately 12.6 years (33%) duty cycle. However, the electrolyte loss through the crimp seal may reduce the 33% duty cycle lifetime somewhat.

Battery lifetime is inversely proportional to the temperature of the battery. At elevated temperatures the battery life will be decreased.

BATTERY REMOVAL:

Caution

There is danger of the new battery exploding if it is incorrectly installed. Only technically qualified personnel should perform battery replacement and disposal. Please note the disposal instructions as described in this section.

Please refer to Figure B - 1 in Appendix B, 'AIM4 CPU Board Layout'. The lithium battery is identified by the 'BT1' designation.

TOOLS REQUIRED:

1. Philips Screwdriver for #6 Philips screws.
2. Electrical tape to tape the old battery after removal
3. QWERTY keyboard to restore CMOS memory settings after replacing the lithium battery

ESD WARNING!

Protective measures against electrostatic discharge (ESD) must be taken when working inside of any computer. Failure to do so may result in permanent damage to electrical components within. This damage may be immediate or latent (final computer failure may occur at a later date). Be sure to make consistent 'skin to metal' contact with the computer chassis when making contact with any electrical assemblies or components.

TO GAIN ACCESS TO THE BATTERY AND REPLACE:

1. Remove power from the 4700 series computer. If installed in a panel the computer must be removed and placed screen down on a bench. To work on the computer on the bench you must first place a soft clean cloth on the clean surface of the bench in order to prevent scratches to the display overlay or touch screen. If the computer includes a front panel mouse, then be sure to prop up the bottom edge of the front panel with a soft object in order to prevent damage to the panel mouse controller. Do not rest the face of the computer on the mouse controller.
2. Remove the top cover of the rear chassis (4715: five #6 screws)
3. Locate the battery holder and remove the coin cell battery:

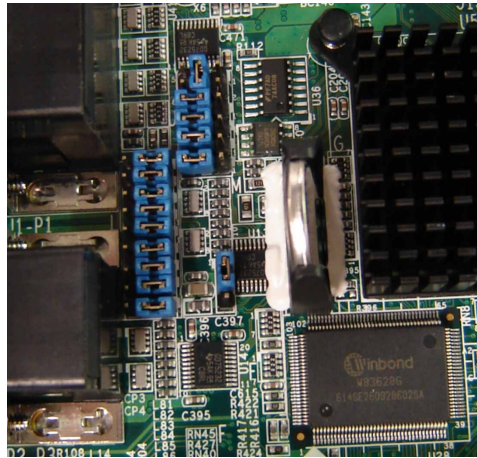

4. Immediately apply electrical tape to the old battery on all sides in order to prevent shorting the battery. The battery may still have charge and a short may cause fire or explosion. Do not dispose of the battery with standard waste. Contact your local waste disposal agency for the address of the nearest battery deposit site.
5. Install the new battery as indicated below. Note position of '+' sign.

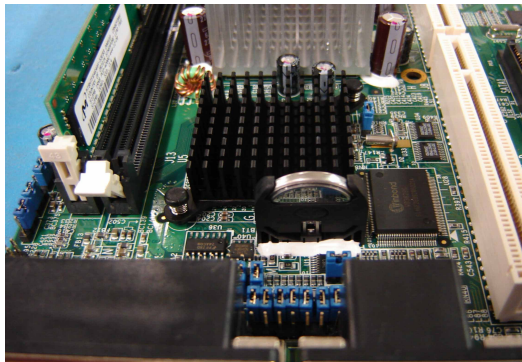

TO RE-ASSEMBLE THE 4700 SERIES COMPUTER:

1. Install the rear chassis top cover (4715: five #6 screws).

TO SETUP THE CMOS MEMORY:

1. Plug a QWERTY keyboard into the Keyboard port on the side of the 4715 series computer
2. Apply power to the 4715 series computer. The same ERROR and WARNING messages should appear as before battery replacement. This is because the CMOS memory must be setup:

```

ERROR
0271: Check Date and Time Settings
Warning
0251: System CMOS Checksum Bad - Default
Configuration Used

```

Press <F1> to Resume, <F2> to Setup

3. Press the QWERTY keyboard F2 function key to enter CMOS Memory SETUP
4. The SYSTEM TIME and SYSTEM DATE fields are located at the top of the MAIN tab screen. Use the UP and DOWN arrow keys on the keyboard to move from field to field. Use the TAB key to move between the [HH:MM:SS] and [MM/DD/YYYY] sub-fields to enter the present time and date.
5. Press the QWERTY keyboard F10 function key to SAVE AND EXIT.
6. Lithium battery replacement is now complete. The computer should boot with no error or warning messages.

Product Repair Program

Pro-face's Product Repair & Customization Department (PR&C) restores equipment to normal operating condition and implements engineering changes that enhance operating specifications. Pro-face tests products returned to Pro-face with the standard Pro-face test diagnostics.

Follow the steps below to prepare the unit for shipment:

1. Obtain an Return Merchandise Authorization (RMA) number for your unit by visiting the Pro-face RMA Request web page and fill out the online request form:

<http://www.profaceamerica.com/rma/>

If you cannot fill out the online form, there is an RMA Request Form Document that can be downloaded and either E-mailed (support@profaceamerica.com) or Faxed (734-429-1010) to the Pro-face Customer Support Team.

If you have difficulty then please call the Pro-face Customer Support Team at (734) 944-0482).

2. Please have the following information:
 - Company name, shipping and billing address
 - Type of service desired: product repair or product exchange
 - Product model number, part number, quantity, serial number(s), and warranty status
 - Failure mode and failure systems
 - Purchase order number or repair order number
3. Make sure the front panel assembly is properly attached to the unit.
4. Attach failure information to the unit to speed processing.
5. Place the unit securely in its original packaging or an equivalent heavy-duty box.
6. Mark the RMA number on your purchase order and on the outside of the box.
7. Send the unit to the address given when you receive your RMA number.

Front Panel Frame

The front panel frame for all 4715's is made of powder-coated aluminum. The key ingredients are pure polyester, TEPIC-G, titanium oxide, barium sulfate, leveling agent, and carbon black. Material that may come in contact with the 4715 unit should be carefully evaluated under end-use conditions for compatibility. See Table 4-1, Table 4-2, and Table 4-3 for a list of compatible and incompatible chemicals.

Chemicals Compatible with 4715T Frame

Table 4-1 should be used only as a guide. Specific testing should be conducted to verify that the unit's finish would meet the demands of extreme environments.

Table 4-1. 4715 Front Panel Frame Chemical Compatibility

Aliphatic hydrocarbons ⁺	Alcohols ⁺	Ketones ^{+•}	Esters ^{+•}
Aromatic hydrocarbons ⁺	Inorganic acids ⁺	Organic acids [•]	Ethers ⁺
Detergents, cleaners ⁺	Waxes (heavy oils) ⁺⁺	Greases (non-reactive organic esters) ⁺⁺	Petrol ⁺⁺
Cooling liquid (glycol) ⁺⁺	Brake fluid (heavy alcohol) ⁺	Oils (unsaturated aliphatic mixtures) ⁺⁺	UV ⁺

++ very good – found unaffected in its performances with regard to time, temperature and stress

+ good – found acceptable in normal exposure; long terms exposure may result in minor loss of properties; higher temperatures may result in major loss of properties

+• fair – found marginal; only for short exposures at low temperatures or when loss of mechanical properties is not critical

Chemicals Not Compatible with 4715T Frame

The following chemicals are known not to be compatible with the 4715 front panel frame:

Table 4-2. Chemicals Not Compatible with the 4715 Frame

Phenols	Oxidizing acids
Partly halogenated hydrocarbons	Fully haolgenated hydrocarbons
Alkalis	

Chemicals Compatible with all 4715 Frames

Table 4-3 should be used only as a guide. Specific testing should be conducted to verify that the unit's finish would meet the demands of extreme environments.

Table 4-3. 4715 Front Panel Frame Chemical Compatibility

CHEMICAL	H	C	CHEMICAL	H	C	CHEMICAL	H	C
Acids:			Alkalies:			Solvents:		
Acetic, 10%	F	P	Ammonium Hydroxide	P	P	Alcohols	E	E
Acetic, Glacial	P	P	Calcium Hydroxide	P	P	Aliphatic Hydrocarbons	G	G
Benzene Sulfonic, 10%	F	P	Potassium Hydroxide	P	P	Aromatic Hydrocarbons	G	F
Benzoic	E	E	Sodium Hydroxide	P	P	Chlorinated Hydrocarbons	P	N
Boric	E	E	Acid Salts:			Ketones	F	P
Butyric, 100%	F	P	Aluminum Sulfate	E	E	Ethers	F	P
Chloroacetic, 10%	E	E	Ammonium Chloride*	E	E	Esters	F	P
Chromic, 5%	P	P	Copper Chloride*	E	E	Gasoline	E	E
Citric, 10%	E	E	Iron Chloride*	E	E	Carbon Tetrachloride	G	G
Fatty Acids	E	E	Nickel Chloride*	E	E	Organics:		
Fluosilicic	P	P	Zinc Chloride*	E	E	Aniline	P	P
Formic, 90%	P	P	Alkaline Salts:			Benzene	F	P
Hydrobromic, 20%	G	F	Barium Sulfide	E	E	Formaldehyde, 37%	G	G
Hydrochloric, 20%	G	F	Sodium Bicarbonate	E	E	Phenol, 5%	G	F
Hydrocyanic	E	E	Sodium Carbonate	E	F	Mineral Oils	E	E
Hydrofluoric, 20%	P	P	Sodium Sulfide	E	F	Vegetable Oils	E	E
Hypochlorous, 5%	G	F	Trisodium Phosphate	G	F	Chlorobenzene	G	F
Lactic, 5%	F	P	Neutral Salts:					
Maleic, 25%	E	E	Calcium Chloride*	E	E			
Nitric, 5%	F	F	Magnesium Chloride*	E	E			
Nitric, 30%	P	P	Potassium Chloride*	E	E			
Oleic	E	E	Sodium Chloride*	E	E			
Oxalic	E	E						
Phosphoric	G	F						
Picric	G	F						
Stearic	E	E						
Sulfuric, 50%	F	P						
Sulfuric, 80%	P	N						
Tannic	E	E						

Key:

E - no attack
N - rapidly attacked

F - some attack, but useable in some instances
C - cold, 70°F (21.1°C)

G - appreciably no attack
H - hot, 180°F (82.2°C) or boiling point of solvent

P - attacked, not recommended for use
* - and nitrate and sulfate

Front Panel Overlay

The 4715 front panel polyester overlay may be adversely affected by combinations of chemical environments, temperature, and stress. For this reason, material that may come in contact with the 4700 unit should be carefully evaluated under end-use conditions for compatibility.

Chemicals Compatible with Overlay

The 4715 front panel overlay withstands more than 24 hours of exposure to the chemicals listed in Table 4-4 without visible change.

Table 4-4. Front Panel Overlay Chemical Compatibility

Ethanol	Acetaldehyde	Fluorochlorohydrocarbons
Cyclohexanol	Aliphatic hydrocarbons	Perchloroethylene
Glycol	Petrol	1.1.1. Trichloroethane
Isopropanol	Toluene	Trichloroethylene
Glycerine	Xylene	Ethylacetate
Methanol	Benzene	Diethyl ether
Acetone	Formic acid <50%	Sodium hypochlorite <20%
Methyl ethyl ketone	Acetic acid <50%	Hydrogen peroxide <25%
Dioxan	Phosphoric acid <30%	Potassium carbonate
	Hydrochloric acid <10%	Washing powders
	Nitric acid <10%	Fabric conditioner
	Sulphuric acid <10%	
Ammonia <2%	Cutting oil	
Caustic soda <2%	Diesel oil	
Alkalicarbonate	Linseed oil	
Bichromate	Paraffin oil	
Potassium ferrocyanide/ ferricyanide	Blown castor oil	
	Silicone oil	
	Turpentine substitute	

Compatible Cleaning Agents for Overlay

The following list contains known cleaning agents and household products that are compatible with the 4700 front panel overlay. If you want to use a cleaning agent that is not listed below, contact the appropriate manufacturer for compatibility.

Ariel®	Domestos®	Downey®	Fantastik®
Formula 409®	Jet Dry®	Lenor®	Persil®
Vim®	Vortex®	Windex®	Wisk®

Chemicals Not Compatible with Overlay

The following chemicals and household products are known to be non-compatible with the 4715 front panel overlay:

Benzyl alcohol	Concentrated caustic solution	Concentrated mineral acids
Lemon juice	Methylene chloride	Tomato juice
Tomato ketchup	High pressure steam over 212°F(100°C)	

Chapter 5 Troubleshooting

Diagnostic Testing

If you suspect that you are having hardware problems with your 4715 series, you can use the Pro-face diagnostic utility to check out the PC's various ports and subsystems. The diagnostic utility is on the Documentation and Support Library CD included with your unit.

Create Diagnostic Disk

The first task is to create a diagnostic diskette. The following steps can be done on any computer with a CD-ROM drive and a floppy drive:

1. Create a DOS-bootable diskette.
2. Create a temporary folder on the computer hard drive.
3. There is a self-extracting zip file on the Documentation and Support Library CD located in:

DRIVERS\Computer Diagnostics 99290-001\DOS\xydiag

Run that program and extract the files to the temporary folder you just created.

4. Copy the extracted files onto the DOS-bootable diskette. This diskette will be inserted directly into the 4700 unit's floppy drive.

Prepare the System

Before starting the system tests, perform the following steps:

1. Place the CPU board jumpers and switches to the factory set positions. Refer to Appendix D for these settings.
2. Plug the female end of the AC power cable into the side of the unit and the male end into a properly grounded outlet.
3. Connect the serial loopback connector(s) and the printer cable to the appropriate connectors, and connect a PC/AT or PS/2 keyboard. Figure 5-1 illustrates the wiring necessary for the loopback connection.
4. Default the CMOS setup to the factory settings.

After completing all of the preceding steps, the 4715 unit is ready for diagnostic testing. Follow the directions in the *Running the Tests* section of this chapter.

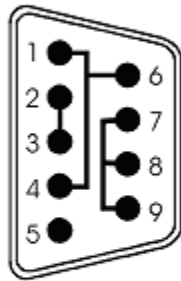

Com 1 RS-232
Serial Loopback
Connections

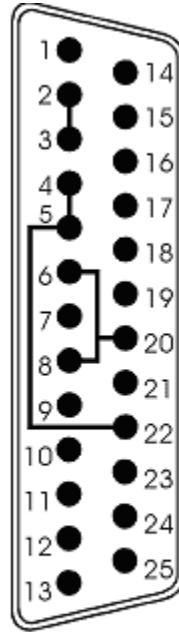

Com 2 RS-232
Serial Loopback
Connections

Figure 5-1. Serial Loopback Connections

Running the Tests

To run the diagnostic tests, insert the DOS-bootable disk you created into drive A. Turn on the computer and the diagnostics program will boot-up. Figure 5-2 shows the Main Menu screen for the program.

```

          Copyright xxxx, <Company Name> ,All rights reserved.
          Diagnostic Tests Sequence/Selection Menu (Rel. xx)
1. WILL pause on error           5. Auto-select tests
2. SINGLE PASS test mode        6. Deselect all tests
3. Save setup to file           7. Quit and exit to DOS
4. Extract setup from a file     8. Return to previous screen
-----
A) RAM Test
B) Video RAM Test
C) Extended RAM Test
D) Real Time Clock Test
E) COM1 Serial Port Test
F) COM2 Serial Port Test
G) COM3 Serial Port Test
H) COM4 Serial Port Test
I) Math Coprocessor Test
J) Video Adjustments Test
K) Video Interface Test
L) Speaker Port Test
M) LPT1: Printer Port Test
N) LPT2: Printer Port Test
O) C: Hard Drive Interface Test
P) D: Hard Drive Interface Test
Q) A: Floppy Drive Interface Test
R) B: Floppy Drive Interface Test
S) Keyboard, Keypad Tests
   = = Test Selected
-----
          [ENTER]=START TESTING
Use the letters to move the cursor and select/deselect, or use the arrow
keys to move, then use the [SPACE] key to select/deselect a test or
function.

```

Figure 5-2. Main Menu

Note

Please read the DIAG.TXT file on the diagnostics disk for detailed information about the tests.

Note

Avoid repeated running of any hard disk diagnostic utility if you use the Solid State (Flash) drive option. The Flash drive has a limited number of writes to each logical sector. Repeated writes from a diagnostic utility will prematurely shorten the life of the drive.

The 4715 series CPU ships with either Windows® 2000, or Windows® XP Professional operating system. If you need to reinstall an operating system, refer to the appropriate section below. If you want to change operating systems, you will need to use the manufacturer's instruction manual.

Note

If you need to reinstall the Windows® 2000 or Windows® XP Professional operating system, you must have an internal CD-ROM drive or an external parallel port CD-ROM drive.

Windows® 2000 Reinstallation

If you need to reinstall the Windows® 2000 operating system, refer to the *Pro-face/Xycom Workstation Recovery Media Software Installation Instructions for Microsoft® Windows® 2000* (shipped with systems preinstalled with Windows 2000). This document is devoted to the reinstallation of your Windows 2000 operating system and drivers, utilizing the Recovery Media provided with your Pro-face/Xycom industrial computer. If you want to install a new operating system or reinstall a current operating system, refer to the operating system's manual for directions.

Note

This procedure assumes that the computer hard disk drive has been completely corrupted or replaced.

Warning

This procedure will destroy data that may exist on the hard disk drive.

Windows XP® Reinstallation

If you need to reinstall the Windows® XP operating system, refer to the *Pro-face/Xycom Workstation Software Installation Instructions For Microsoft Windows XP* (shipped with systems preinstalled with Windows XP). This document is devoted to the reinstallation of your Windows XP operating system and drivers, utilizing the XP CD provided with your Pro-face/Xycom industrial computer. If you want to install a new operating system or reinstall a current operating system, refer to the Windows XP Professional CD-ROM (shipped with systems preinstalled with Windows XP Professional).

Note

This procedure assumes that the computer hard disk drive has been completely corrupted or replaced.

Warning

This procedure will destroy data that may exist on the hard disk drive.

Installing Drivers

This section describes how to install the drivers associated with the system.

Note

For further assistance, contact Pro-face technical support at 734-944-0482 or support@profaceamerica.com.

Video Drivers

Video drivers are on the Documentation and Support Library CD included with the documentation kit.

For the AIM4 system, choose the video driver for your operating system from the following directory on the Documentation and Support Library CD:

\\DRIVERS\\AIM4

Note: the video driver is part of the Intel chipset

Video Expansion

This section deals with the hardware expansion capability of the video controller chip in DOS applications.

Note

It is *not* necessary to read this section if you are a Windows® or OS/2 user and do not plan to run DOS applications.

Unlike a CRT monitor, a flat panel display has a fixed horizontal and vertical resolution. There are many DOS video modes whose resolution is less than that of a flat panel display. In order to more efficiently make use of the flat panel display's active area, it is necessary to employ an expansion technique, which stretches the lower resolution information to fill the higher resolution of the display.

For example, DOS defaults to VGA video mode 3+. This is an 80 column, 25-row text only screen whose effective resolution is 640 dots x 400 scan lines. Because of this, the 1024 x 768 display of the system will be partially filled by the 640 x 400 resolution of this particular mode. The expansion function built into the scaler chip Pro-face adds uses lower resolutions that will better utilize the display by stretching the information in an attempt to fill the display.

Operating systems such as Microsoft Windows® 98 and Windows® NT use display drivers to handle the different flat panel displays. Here, expansion is not necessary since there is a specific driver for each resolution display.

Expansion does not add any resolution to the existing information; it simply stretches the information to better fit the display. Text and graphic screens can look somewhat grainy from the process of expansion.

Touch Screen Drivers

If you have a touch screen driver that has been factory installed, you will also receive, pre-loaded and at no extra charge: Windows® 2000, and Windows® XP Professional touch screen drivers.

Note

If you ordered a system pre-loaded with an operating system, the touch screen driver was pre-installed.

You must install the corresponding touch screen driver software if you change the operating system. The touch screen drivers are located on the Document and Support Library CD under:

\\DRIVERS\\TOUCHSCREEN\\TOUCH-BASE

Choose the PS/2 driver.

Miscellaneous Drivers

Refer to your operating system and peripheral manuals for information on installing drivers related to these items.

Note

If you ordered a system with Windows pre-loaded, you may have to purchase and install an external parallel port CD-ROM drive, or order your system with a CD-ROM drive pre-installed, to be able to install Windows drivers. The Windows operating system ships only on CD-ROM.

Appendix A – Technical Specifications

Hardware Specifications

Table A - 1 lists the hardware specifications for the 4715T and 4715KPM(T).

<i>Table A - 1. Hardware Specifications</i>			
Characteristic	Specification		
	4715		4715
Mechanical	4715T		4715KPM(T)
Height	12.62"	Front Panel	13.97" Front Panel
Width	16.59"	Front Panel	19.00" Front Panel
Depth	7.64"	overall	7.64" overall
	6.64"	behind front panel	6.64" behind front panel
	1.00"	front panel protrusion	1.00" front panel protrusion
Weight	25 lb		26 lb
Electrical			
AC	100-240 VAC	50-60 Hz	1.0A maximum
DC	19 – 36 VDC		3.5A maximum
Power Supply	250 watts		250 watts
Passive Backplane	Four available expansion slots: one ½ length PCI two ¾ length PCI one ¾ length PCI or ISA		
Available Power (for expansion by user)	+3.3 V 4.00A maximum +5 V 4.00A maximum -5 V 160mA maximum +12 V 3.00A maximum -12 V 240mA maximum		+3.3 V 4.00A maximum +5 V 4.00A maximum -5 V 160mA maximum +12 V 3.00A maximum -12 V 240mA maximum
Mounting	Panel Mount or 19" rack with optional filler plate.		
Flat Panel	15" TFT active color display		15" TFT active color display
Agency Approvals	UL 508 (Listed) UL 1604 (Listed) cUL CSA C22.2, No. 142 (Listed) cUL CSA C22.2, No. 213 (Listed)		
Regulatory Compliance	FCC 47 CFR, Part 15, Class A CE EMI EN55022, Class A IMMUNITY EN61000-6-2 SAFETY EN60950 HARMONICS EN61000-3-2, Class A FLICKER EN61000-3-3		

Environmental Specifications

Table A - 2. Environmental Specifications lists the environmental specifications for the 4715T and 4715KPM(T).

Table A - 2. Environmental Specifications

Characteristic	Specification
Temperature	
Operating	0° to 50° C (32° to 122° F)
Non-operating	-20° to 60° C (-4° to 140° F)
Humidity	
Operating	20% to 80% RH, non-condensing
Non-operating	20% to 80% RH, non-condensing
Altitude*	
Operating	Sea level to 10,000 feet (3,048 m)
Non-operating	Sea level to 40,000 feet (12,192 m)
Vibration (5 to 2000 Hz)	
Operating**	0.006" (0.15mm) peak to peak displacement 1.0g maximum acceleration
Non-operating	0.015" (0.38mm) peak to peak displacement 2.5g maximum acceleration
Shock	
Operating**	15g peak acceleration, 11 msec duration, ½ sine wave
Non-operating	30g peak acceleration, 11 msec duration, ½ sine wave

* Consistent with internal component specifications

** These values are with solid-state hard drives and not rotating media drives.

Appendix B –Block Diagram and AIM4 Layout

Figure B - 1 shows the layout of the AIM4 CPU board layout

AIM4 CPU Board Layout

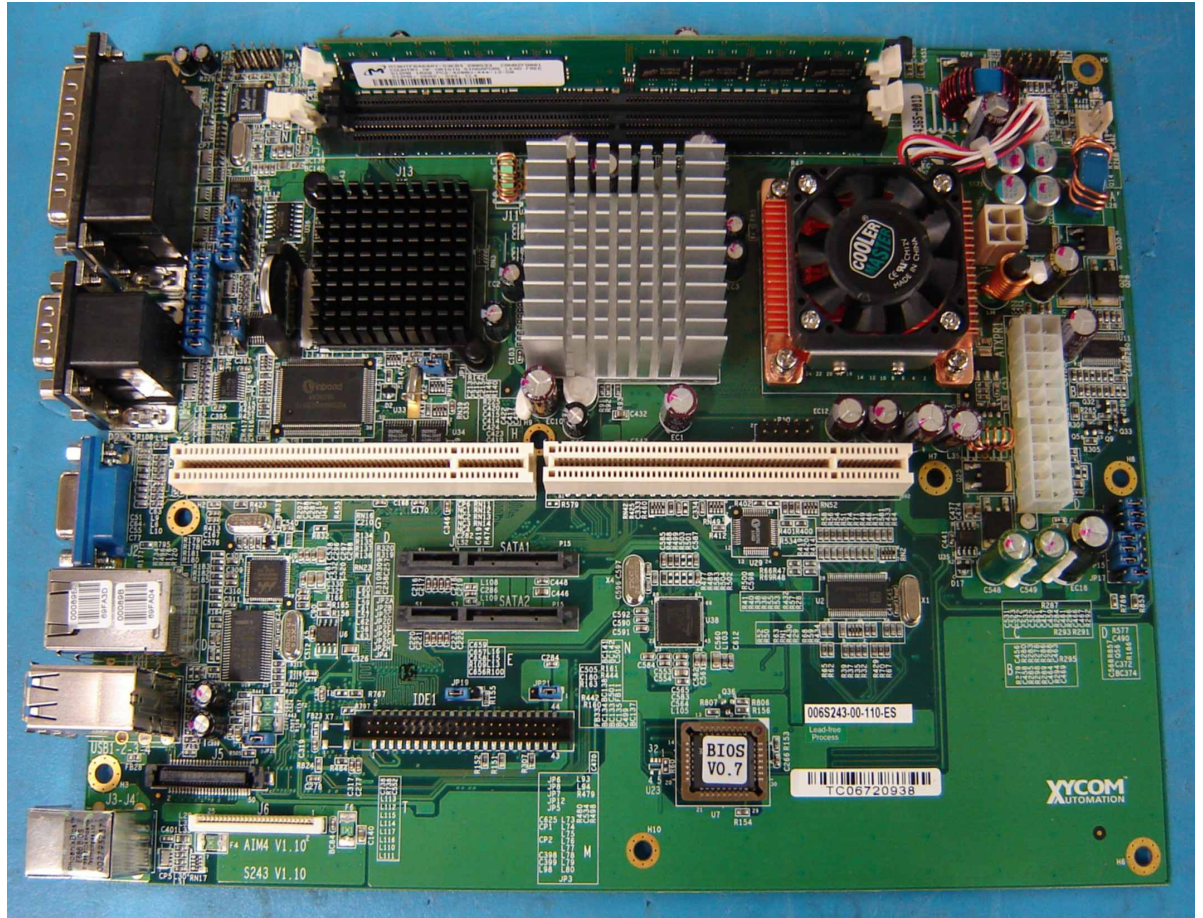

Figure B - 1. AIM4 CPU Board Layout w/Jumper & Connector Locations

Appendix C – Pinouts

This appendix provides the pinouts for the keyboard, mouse, LPT1, COM1, COM2, USB, and VGA connectors. **NC indicates No Connection.**

Keyboard Port Connector

The following table lists the signal definitions for the keyboard connector. It is a standard PS/2-compatible connector.

Table C - 1. Keyboard Connector Pinout

Pin	Signal
1A	KB_DATA
2A	NC
3A	GND
4A	5VFUSE
5A	KB_CLK
6A	NC

Mouse Port Connector

The following table lists the signal definitions for the PS/2 mini-DIN mouse port connector.

Table C - 2. Mouse Connector Pinout

Pin	Signal
1B	MOUSE_DATA
2B	NC
3B	GND
4B	5VFUSE
5B	MOUSE_CLK
6B	NC

Four USB Connector (USB1)

The following table lists the signal definitions for each of the four USB connectors.

Table C - 3. Four USB Pinout

Pin	Description
1	5VFUSE
2	USBP0-
3	USBP0+
4	GND

Parallel Port Connector (LPT1)

The following table shows the signal definitions for the DB-25 Parallel port connector.

Table C - 4. Parallel Connector Pinout

Pin	Signal	Pin	Signal
1	STROBE	14	AUTOFEED
2	PD(0)	15	PERROR
3	PD(1)	16	INIT
4	PD(2)	17	SELIN
5	PD(3)	18	GND
6	PD(4)	19	GND
7	PD(5)	20	GND
8	PD(6)	21	GND
9	PD(7)	22	GND
10	PACK	23	GND
11	PBUSY	24	GND
12	PE	25	GND
13	SELECT		

Serial Port Connectors

RS-232, RS-422 and RS-485 are supported by AIM4.

COM1

The following table lists the signal definitions for the COM1 DB-9 connector.

Table C - 5. COM1 Connector Pinout

RS-232		RS-422		RS-485	
Pin	Signal	Pin	Signal	Pin	Signal
1	DCD1	1	TXD- (note 1)	1	DATA- (note 1)
2	RXD1	2	TXD+ (note 1)	2	DATA+ (note 1)
3	TXD1	3	NC	3	NC
4	DTR1	4	NC	4	NC
5	GND	5	GND	5	GND
6	DSR1	6	RXD-	6	NC
7	RTS1	7	RXD+	7	NC
8	CTS1	8	NC	8	NC
9	RI1	9	Voltage (note 2)	9	Voltage (note 2)

Note

150Ω termination resistors can be connected across transmit or receive lines by inserting jumpers JP5 and JP7. Refer to Appendix D.

COM2

The following table lists the signal definitions for the COM2 DB-9 connector.

Table C - 6. COM2 Connector Pinout

Pin	Signal
1	DCD2
2	RXD2
3	TXD2
4	DTR2
5	GND
6	DSR2
7	RTS2
8	CTS2
9	RI2

COM3

The following table lists the signal definitions for the COM3 DB-25 connector.

Table C - 7. COM3 Connector Pinout

Pin	Description	Pin	Description
1	CHASSIS GND	14	NC
2	TXD3	15	NC
3	RXD3	16	NC
4	RTS3	17	NC
5	CTS3	18	NC
6	DSR3	19	NC
7	GND	20	DTR3
8	DCD3	21	NC
9	NC	22	RI3
10	NC	23	NC
11	PB_RESET#	24	NC
12	NC	25	NC
13	NC		

Note: The P1 connector contains a remote system reset option. The reset jumper

(JP1) shall be in position 1-2 in order to activate the Reset function. The PB_RESET pin shall be switched to GND to reset the entire board.

COM4

The following table lists the signal definitions for the COM4 DB-9 connector.

Table C - 8. COM4 Connector Pinout

Pin	Signal
1	DCD4
2	DSR4
3	RXD4
4	RTS4
5	TXD4
6	CTS4
7	DTR4
8	RI4
9	GND
10	NC

Note: COM4 to be employed when using a UPS type power supply containing RS-232 monitoring capability.

VGA Connector

The following table lists the signal definitions for the VGA DB-15 connector.

Table C - 9. VGA Connector Pinout

Pin	Signal	Pin	Signal
1	RED	9	Fused VCC
2	GREEN	10	ORB_GND
3	BLUE	11	NC
4	NC	12	DDCDAT
5	ORB_GND	13	HSYNC
6	ORB_GND	14	VSYNC
7	ORB_GND	15	DDCCLK
8	ORB_GND		

APPENDIX D – AIM4 CONTROLLER JUMPERS

The following tables show the position and function of the controller jumpers.

Note: * Indicates factory default position.

Clear CMOS Settings

JP1	Description
1-2*	Normal Operation
2-3	Clear CMOS Settings

CPU Voltage Select

JP22	Voltage Select	CPU
1-2*	1.8V (400MHz FSB)	1.3Ghz Celeron M
2-3	1.5V (533MHz FSB)	2.0Ghz Pentium M

LCD Setup Settings

LCD Power Select

LCD Panel	JP9	LCD Voltage
12.1" AU Optronics	1-2	+3.3VDC
15" AU Optronics	1-2	+3.3VDC
Node Box Configuration	1-2	+3.3VDC

Note: +5VDC operation is available when JP9 is in position 2-3

LCD Mode Selection

JP10	Operating Mode
2-3*	6-Bit Compatibility
1-2	8-Bit Compatibility

Note: Only specific LCD panels support these features

Normal/Reverse Scan Select

JP11	Scan Mode
2-3*	Normal Scan
1-2	Reverse Scan

Note: Only specific LCD panels support these features

LCD Resolution

JP13	JP14	JP15	JP16	Display Size	LCD Resolution
1-2	1-2	2-3	2-3	15"	1024 X 768
1-2	1-2	2-3	1-2	17"	1280 X 1024
1-2	1-2	1-2	2-3	12"	800 X 600
1-2	1-2	1-2	1-2	19"	1600 X 1200
1-2	1-2	1-2	2-3	N/A	Node Box Operation

CRT/LCD Select

JP17	Display Select
1-2*	CRT & LCD
2-3	CRT Only (Node Box Configuration)

HDD/CDROM Settings**SATA Mode Select**

JP18	HDD Mode
1-2	Reserved
2-3*	IDE Mode

IDE1 Connector - Master/Slave Mode

JP19	IDE Master/ Slave Select
1-2	Master
2-3*	Slave

Note: Affective only when drive is physically jumpered for Cable Select

J5 Connector – CDROM Master/Slave Mode

JP20	CDROM Master/Slave Select	
1-2*	Master	Note 1
2-3	Slave	
1-2	Slave	Note 2
2-3*	Master	

Note:

1. Affective only when CDROM is programmed for Cable Select Mode
2. Affective only when CDROM is programmed for Reverse Cable Select Mode

IDE1 Connector – Voltage Select

JP21	IDE1 Voltage Select
1-2*	Compact Flash Mode: +3.3VDC
2-3	HDD, etc: +5VDC

Comm Port Settings

P2 - Comm 1 Connector Mode Configuration

Jumper	RS-232 Mode	RS-422 Mode	RS-485 Mode
JP2A	1-2*	2-3	2-3
JP2B	1-2*	2-3	2-3
JP2C	1-2*	2-3	2-3
JP2D	1-2*	2-3	2-3
JP2E	1-2*	2-3	2-3
JP2F	1-2*	2-3	2-3
JP2G	1-2*	2-3	2-3
JP2H	1-2*	2-3	2-3

Comm Configuration Jumper

JP8	Comm 1 Communication Mode
1-2	RS-485
2-3*	RS-422

P2 - RS-422/485 Terminator Configuration

Jumper	RS-422 Mode		RS-485 Mode	
	Terminator Out	Terminator In	Terminator Out	Terminator In
JP5	2-3*	1-2	2-3	1-2
JP7	2-3*	1-2	Note 1	Note 1

Note: 1. Jumper not used. Insert in factory default position.

P2 - Comm 1 External Voltage Select

JP3	Output Voltage at P2, Pin 9
1-2*	+5VDC Output
2-3	+12VDC Output

Note: Either +5VDC or +12VDC will appear on P2, Pin 9 when jumpered for RS-422 or RS-485.

P2 – Comm 1, RS-485 Transmit Gating Options

Transmit Enable	JP4	JP6
DTR Active	1-2*	3-4*
DTR Inactive	1-2	1-2
RTS Active	2-3	3-4
RTS Inactive	2-3	1-2
Auto Turn-Around	Note 1	5-6

Note: 1. Jumper not used. Insert in factory default position.

External Reset Enable – Comm 3

JP12	Description
1-2	External AIM4 Reset Active
2-3*	Normal Operation

APPENDIX E – TSKAM JUMPER & SWITCH SETTINGS

TSKAM Board 1, Part Number 143913-001

The following tables indicate the jumper and switch settings for the TSKAM.

SW1 – Keypad Mapping

Map Selection	SW1 Positions							
	1	2	3	4	5	6	7	8
46/4700 *	Off	Off	Off	Off	Off	Off	Off	Off

H8 Program Mode

Mode	JP2	JP3	JP7	JP8
Normal Mode*	A	A	B	B
Programming Mode	B	B	A	A

Inverter Control Jumpers

Inverter Brightness Control Range Setting

LCD	Voltage Range	JP4
12.1" Display	0 – 3.5 VDC	A
15" Display	0 – 3.5 VDC	A

Inverter OFF Signal Polarity

Display Type	Function	JP5
12.1" Display	Low = Inverter OFF	A
15" Display	Low = Inverter OFF	A

Invert ON/OFF Signal Drive Voltage

Function	JP6
ON/OFF Drive +5V	A
ON/OFF Drive +12V	B *

APPENDIX F – BACKPLANE JUMPER SETTINGS

4-Slot PCI Backplane Jumper Settings

<i>Jumper</i>	<i>Position</i>	<i>Function</i>
<i>J1</i>	<i>A*</i>	<i>CMOS OK</i>
Note 1	<i>B</i>	<i>Clear CMOS</i>
<i>J2</i>	<i>A*</i>	<i>ROM/ROM Site PIN 30 = SA(17) For a 32-Pin NVRAM</i>
	<i>B</i>	<i>ROM/RAM Site PIN 30 = +5V For a 28-Pin NVRAM</i>

Note 1: The CMOS Clear function is not available on 4700 & 4700 products.

Index

AC power cable		
constructing.....	18	
Access		
keyboard port.....	7	
AIM3		
jumpers	66	
Back panel	10	
Battery.....	45	
Cable		
communication cable interface	30	
connections.....	29	
COM ports.....	9	
COM1 connector.....	63	
Connectors		
AIM3+		
COM1	63	
parallel port	62	
VGA	65	
Dual USB	62	
keyboard	61	
mouse	61	
serial port	63	
Control drawing		
Hazardous Locations	31	
Custom logo.....	21	
Cutout dimensions	15	
Definitions		
class and division.....	27	
Class I locations.....	27	
Class II locations.....	27	
Division 1 locations	27	
Division 2 locations	28	
Enclosures	29	
Groups	28	
DIMM.....	19	
Display	5, 7	
Documentation kit	12	
DRAM.....	19	
Driver		
touch screens.....	20	
Drivers		
installing	56	
miscellaneous	57	
touch screen	57	
video	56	
Dual Inline Memory Modules.....	19	
Fan.....	11, 43	
filter replacement	43	
Features		
optional	3	
standard	1	
Front panel.....	4	
Front panel frame		
chemical compatability.....	49	
chemical incompatibility.....	49	
Front panel overlay		
chemical compatability.....	51	
chemical incompatibility.....	51	
Fuse		
replacement	43	
Hard drive setup information.....	11	
Heat, excessive.....	17	
I/O Panel	8, 9	
ID label.....	11	
Installation		
DRAM.....	19	
hazardous locations	25	
internal hardware	19	
operating systems.....	55	
PC/AT and PCI boards.....	19	
Installing		
driver	56	
Jumper settings		
AIM3 CPU board	66	
TSKAM.....	70, 71	
Keyboard		
connectors	61	
Keyboard port	7, 9	

Keypad	serial	9
scan codes	video	9
Keypad inserts	Power	
creating custom	system	16
Keypad Inserts	Power connector	11
Keypad utility	Power receptacle	11
Download menu	Power supply	16
Exit menu	Power switch	29
Files menu	Preparing the system	13
Macros Keypad Type Menu	Preventive maintenance	43
Main menu	battery	45
Upload menu	general	43
using	hard drive	44
Utilities menu	Printer port	9
Keypad Utility Program	Product repair program	48
LEDs	Reinstalling	
Line voltage variation	Windows 2000	55
Logo, custom	Windows XP	55
Maintenance	Returning the unit	48
battery	Safety agency approval	26
general	Serial port connectors	63
hard drive	Serial ports	9
Mouse port	Setup information, hard drive	11
Noise, electrical	Startup	
Parallel port connector	quick	12
PC/AT installation and PCI boards	System	
Pinouts	maintenance	32
COM1	operation	32
COM2	System components	
Dual USB connector	Front panel	4
keyboard connector	System Power	16
mouse connector	Testing	
parallel port	diagnostic	52, 54
VGA connector	Touch screen drivers	57
Ports	Touch screens	
COM	calibrating	21
keyboard	driver	20
mouse	TSKAM	
parallel	jumper settings	70, 71
printer	switch settings	70, 71

Using the Keypad Utility.....34
Utility Batch Mode39
VGA connector.....65

Video drivers56
Video expansion56
Video port.....9

144813(B)

Xycom Automation, LLC
734-429-4971
Fax: 734-429-1010

<http://www.profaceamerica.com>

Canada Sales: 905-607-3400
Northern Europe Sales: +44-1604-790-767
Southern Europe Sales: +39-011-770-53-11

