

9000-CAP-3615T/3515 Cutout Adapter Plate Installation

With the 9000-CAP-3615T/3515 cutout adapter plate, you can mount the 3615T in an existing 3515 panel cutout. The installed 9000-CAP-3615T/3515 and front panel assembly will be NEMA 4/4X/12 sealed.

Follow this mounting procedure:

1. Remove the old unit from the existing panel cutout.
2. Mount the front panel of the replacement unit to the cutout adapter plate as shown in Figure 1. Torque 10-32 UNF nuts to 25 lbs-inch (12 nuts total).
3. Mount the combined 9000-CAP-3615T/3515 and front panel assembly to the existing cutout as shown in Figure 1. Torque 10-32 UNF nuts to 25 lbs-inch (14 nuts total).

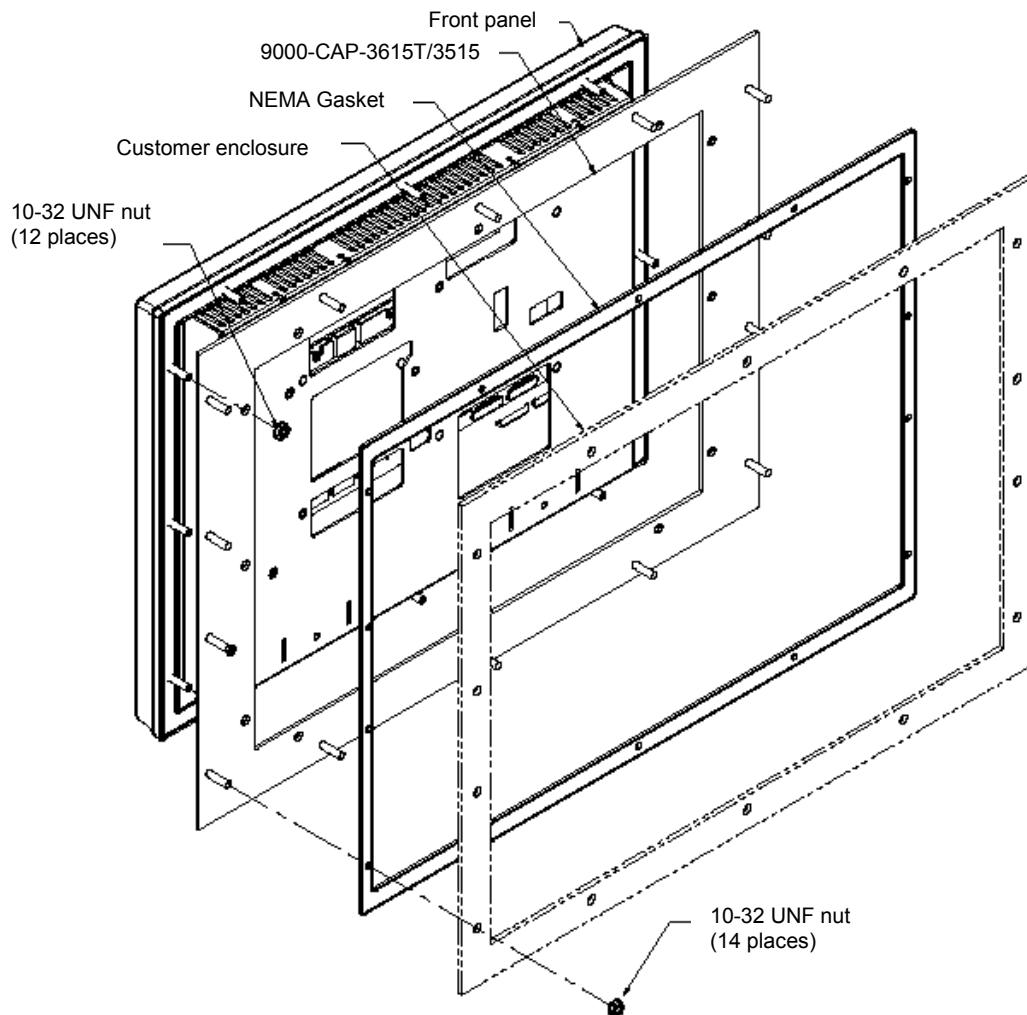

Figure 1. 9000-CAP-3615T/3515 Cutout Adapter Plate Installation