

**9987**

---

PC/AT™ Flat-Panel  
Industrial Computer

P/N 99503-001B

---

## *Xycom Revision Record*

<i>Revision</i>	<i>Description</i>	<i>Date</i>
A	Manual Released	5/94
B	Manual Updated	2/98

### ***Trademark Information***

Brand or product names are registered trademarks of their respective owners.

IPN200 FloNet interface board and FloPro software are trademarks of Diversified Technologies®.

### ***Copyright Information***

This document is copyrighted by Xycom Incorporated (Xycom) and shall not be reproduced or copied without expressed written authorization from Xycom.

The information contained within this document is subject to change without notice.



**xycom**

Technical Publications Department

750 North Maple Road

Saline, MI 48176-1292

734-429-4971 (phone)

734-429-1010 (fax)

---



# Table of Contents

---

<b>Chapter 1 – Introduction</b> .....	<b>1-1</b>
Standard Features .....	1-1
Optional Features .....	1-2
Unpacking the System.....	1-2
Quick Start-up .....	1-2
<b>Chapter 2 – Testing</b> .....	<b>2-1</b>
Checking System Setup.....	2-1
Phoenix BIOS .....	2-1
Quadtel BIOS .....	2-2
Preparing for the Tests .....	2-2
<b>Chapter 3 – Installation</b> .....	<b>3-1</b>
System Components .....	3-1
Front Panel.....	3-1
Back Panel.....	3-3
Power Panel.....	3-4
I/O Panel.....	3-5
Preparing the System.....	3-5
Removing/Reconnecting the Slide-out Computer Module .....	3-6
Removing the Slide-Out Module .....	3-6
Reconnecting the Slide-out Module .....	3-7
Installing Internal Hardware Options .....	3-7
9000-RAD Card.....	3-7
DRAM and Additional DRAM Single-Line Memory Modules (SIMMs).....	3-8
Single-Slot PC Interface Module.....	3-8
FloNet Interface Board .....	3-8
Installing External Hardware Options .....	3-9
Extender Cable .....	3-9
Keyboards .....	3-9
Serial Mouse .....	3-10
Installing Internal Options .....	3-10
Operating Systems .....	3-10
8X14 Font TSR.....	3-10
Video Drivers .....	3-11
Sealed Durapoint Mouse Drivers .....	3-11
Creating a Custom Label.....	3-11
Installing the System into a Panel.....	3-12
Mounting Considerations.....	3-12
System Power.....	3-13
Excessive Heat.....	3-14
Excessive Noise.....	3-14
Excessive Line Voltage.....	3-14
Mounting the 9987 .....	3-15

Installing PC/AT Boards .....	3-16
Installing the CPU into a Chassis .....	3-17
Available Power.....	3-18
Hazardous Locations Installations .....	3-18
Safety Agency Approval.....	3-19
Definitions .....	3-20
Enclosures .....	3-22
Power Switch.....	3-23
Cable Connections.....	3-23
Operation and Maintenance.....	3-24
<b>Chapter 4 – Programmable Keyboard Interface Module.....</b>	<b>4-1</b>
Loading the PKIM Utility.....	4-1
Using the PKIM Utility.....	4-1
PKIM Startup.....	4-2
PKIM Utility Batch Mode.....	4-2
Main Menu.....	4-3
Exit .....	4-3
Files Menu.....	4-3
Macros Menu .....	4-4
Upload Menu .....	4-7
Download Menu.....	4-7
Utilities Menu .....	4-7
Codes.....	4-8
<b>Chapter 5 – Maintenance .....</b>	<b>5-1</b>
Preventive Maintenance.....	5-1
Routine Maintenance.....	5-1
Replacing the Fuse.....	5-2
Replacing the Slide-out Computer Module .....	5-3
Replacing the Fan Filter.....	5-3
Spare Parts List.....	5-4
Product Repair Program/Returning a Unit to Xycom.....	5-4
<b>Appendix A – Technical Specifications.....</b>	<b>A-1</b>
<b>Appendix B – Block Diagram .....</b>	<b>B-1</b>
<b>Appendix C – Pinouts.....</b>	<b>C-1</b>
Keyboard Connectors .....	C-1
COM1/COM2 Serial Port Connectors .....	C-2
VGA Connector (VGA).....	C-2
Parallel Port Connector (LPT1) .....	C-3
Speaker Jack Connector.....	C-3

# Chapter 1 – Introduction

---

The 9987 PC/AT™ Flat-panel Industrial Computer (also known as the Portrait PC) combines a PC/AT computer with a flat-panel display to offer a powerful, compact package for the factory floor and other harsh environments. The 9987 features an open architecture to meet a wide variety of applications where both a powerful PC and a durable industrial enclosure are required. The system integrates a computer card cage, mass storage, display, keypads, and power supply in a truly industrial form factor.

The 9987 system includes a four-slot, full-length, passive ISA backplane, a VGA flat-panel display, hard and floppy disk drive facilities, and data entry/function keypads. The front panel is sealed to NEMA 4/4X/12 standards, and the flat-panel display is protected by an impact-resistant shield. The open-architecture design accepts IBM PC/AT-compatible cards and keyboards.

The processor board combines the functions of a IBM PC/AT-compatible computer on a single, industrially-hardened circuit board. Refer to the Xycom CPU manual for more information on processor and hardware features.

The system's modular design allows easy access to boards, switches, power supply, and disk drives. You can easily remove the drawer by detaching six ACCESS fasteners.

## Standard Features

The 9987 offers the following standard features:

- High-performance, single-board 486 and Pentium® processors
- 5.62-inch mounting depth
- Four-slot, full-length, passive ISA backplane
- 10.4-inch 256-color CCFT TFT LCD flat-panel display (640x480)
- 32 data entry and 10 function keys
- 3.5-inch 1.44 Mbyte floppy drive
- MS-DOS®
- Slide-out computer module (to access disk, backplane, and power supply)
- 110-watt power supply
- IBM PC/AT compatibility
- Front or rear access floppy disk
- External printer port
- External COM1 and COM2 ports (RS-232)
- Front panel sealed to meet NEMA 4/4X/12 specifications when panel mounted

## Optional Features

The following optional items are also available with the 9987:

- A variety of high-capacity IDE hard drives and Solid State (Flash) drives
- RADAR card with isolated RS-232C/RS-485 serial ports
- External full-stroke keyboard
- Durapoint sealed front-panel mouse
- Various sealed rack- or panel-mount keyboards
- Preloaded Windows® 95 or Windows NT operating systems
- Hazardous location configurations

## Unpacking the System

When you remove the 9987 from its box, verify that you have the parts listed below. Save the box and inner wrapping in case you need to reship the unit.

- 9987 unit
- Documentation kit, which includes

- Power cable
- PKIM utility disk
- Diagnostic software disk
- 20 hex nuts (6 spares)
- 9987 user manual
- CPU manual
- VGA utility disk
- Binder
- Business reply card

## Quick Start-up

### Warning

Turn off the power to the unit and unplug the power cord before making any adjustments to the inside or outside of the computer.

Perform the following steps to prepare the system for use.

1. Attach optional keyboards/mouse.
  - Connect an external keyboard to the keyboard connector behind the access door on the front panel or to the connector on the power panel.
  - A serial mouse can be connected to either COM1 or COM2. When a mouse is used, the COM LED on the data entry keypad lights up.
2. Attach other optional equipment following the instructions in Chapter 3.
3. Attach the power cord from the power receptacle to a properly grounded 90-250 VAC, 50-60 Hz outlet.
4. Turn on the power to the unit. The system will boot up at the C: prompt.
5. Install application software via drive A: located behind the access door on the front panel.



## Chapter 2 – Testing

---

Diagnostic tests are provided to verify the operation of the 9987 system hardware functions under MS-DOS.

### Note

Diagnostic disks are not included if your system ships with Windows 95 or Windows NT preloaded. These operating systems have built-in diagnostics that are invoked when the operating system boots up.

If any of these tests fail, either you do not have the correct default setting or there is a failure. Check the default settings and run the tests again. If there is another failure, contact Xycom's Product Repair & Customization Department (PR&C).

### Note

Unexpected failures may occur if Xycom diagnostics are run with device drivers or memory resident programs installed on the system. Remove these before running any diagnostic tests.

## Checking System Setup

Ensure that the Setup Menu is configured properly (factory-set configuration). The way you access the Setup Menu depends on the CPU board installed in your system.

### Phoenix BIOS

If the CPU board has a Phoenix BIOS, press F2 to enter the Setup Menu, and then press F2 to display the Main Menu. Make the necessary changes by following the on-screen directions. General instructions for navigating through the Setup screens are described below:

- ←↑↓→ move the cursor left, up, down, and right. Press ENTER to validate your selection.
- ESC exits the menu. You are prompted to save changes.
- F5 selects the previous or smaller value.

- F6 selects the next or higher value.
- F9 automatically configures the system with the default values. These values are defined by the system configuration and the values are set in the Setup Menu.
- F10 loads previous values.

## Quadtel BIOS

If the CPU board has a Quadtel BIOS, press CTRL+ALT+S simultaneously after the POST RAM test has completed to access the Setup Menu. Make changes by following directions on the screen. Press F10 to save the Setup, and ESC to exit. Refer to your CPU manual for more information on the Setup Menu.

## Preparing for the Tests

To test your system, you need the following equipment:

- Xycom System Test Disk (bootable 3.5-inch, DS/DD disk), Xycom part number 99290-001
- IBM PC/AT-compatible keyboard (Xycom part number 91971-001 or equivalent)
- Centronics-compatible printer cable
- Parallel printer (Centronics-style interface)
- Two serial loopback test connectors (refer to Figure 2-1 for pinouts)
- Formatted scratch disk (3.5-inch, DS/HD)

Perform the steps below before starting the system tests:

1. Place the CPU board jumpers and switches to the factory-set positions. Refer to your CPU manual for these settings.
2. Plug the female end of the AC power cable into the side of the unit and the male end into a properly grounded outlet.
3. Connect the serial loopback connector(s) and the printer cable to the appropriate connectors and connect a PC/AT keyboard to a keyboard connector. Figure Chapter 2 -1 illustrates the wiring necessary for the loopback connection.

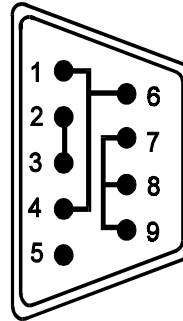

Figure Chapter 2 -1. Serial Loopback Connector

To run the test, insert the diagnostics disk into drive A. Turn on the computer (the diagnostics program will boot up). Figure Chapter 2 -2 shows the Main Menu as it is displayed on the screen.

Copyright 1990-1994, Xycom, Inc. All rights reserved.	
Diagnostic Tests Sequence/Selection Menu (Rel. xx)	
WILL pause on error	Auto-select tests
SINGLE PASS test mode	Deselect all tests
Save setup to file	Quit and exit to DOS
Extract setup from a file	Return to previous screen
A) RAM Test	K) Video Interface Test
B) Video RAM Test	L) Speaker Port Test
C) Extended RAM Test	M) LPT1: Printer Port Test
D) Real Time Clock Test	N) LPT2: Printer Port Test
E) COM1 Serial Port Test	O) C: Hard Drive Interface Test
F) COM2 Serial Port Test	P) D: Hard Drive Interface Test
G) COM3 Serial Port Test	Q) A: Floppy Drive Interface Test
H) COM4 Serial Port Test	R) B: Floppy Drive Interface Test
I) Math Coprocessor Test	S) Keyboard, Keypad Tests
J) Video Adjustments Test	≡ = Test Selected
[ENTER]=START TESTING	
Use the letters to move the cursor and select/deselect, or use the arrow keys to move, then use the [SPACE] key to select/deselect a test or function.	

Figure Chapter 2 -2. Main Menu

### Note

Please read the DIAG.TXT and CMOS.TXT files on the diagnostics disk for detailed information. Refer to the CMOS.TXT file for BIOS setup information.

**Note**

If you use the Solid State (Flash) drive option, avoid repeated running of any hard disk diagnostic utility. The Flash drive has a limited number of writes to each logical sector. Repeated writes from a diagnostic utility will prematurely shorten the life of the drive.

# Chapter 3 – Installation

## System Components

This section describes the 9987's components.

### Front Panel

The 9987 comes equipped with a NEMA 4/4X/12-sealed front panel. When properly panel mounted, this front panel protects the system's interior. See panel-mounting instructions later in this chapter.

Figure Chapter 3 -1 illustrates the front panel features of the 9987.

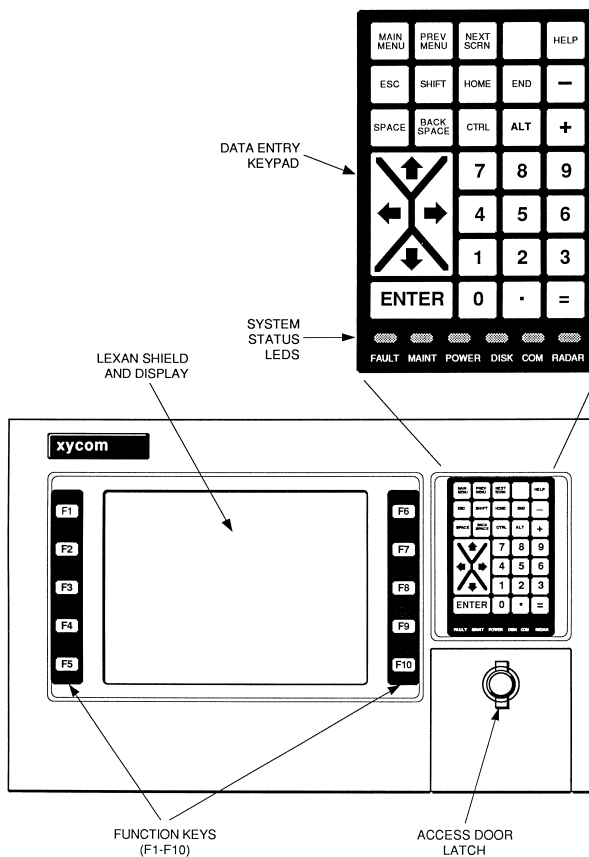

Figure Chapter 3 -1. 9987 Front Panel

<b>Display</b>	The TFT color LCD flat-panel display is protected from breakage by an impact-resistant shield.
<b>Function Keys</b>	The 10 sealed function keys are located to the left and right of the display. They provide the user with easy access to familiar PC software routines.
<b>Data Entry Keypad</b>	This sealed numeric keypad includes the numbers 0-9, and the following data entry keys: Main Menu, Prev Menu, Next Scrn, Help, Esc, Shift, Home, End, -, Space, Back Space, Ctrl, +, Enter, =, arrows, and “.”.
<b>Floppy Disk/Keyboard Port Access</b>	Located below the keypad, this door accesses the floppy disk drive and keyboard port. The keyboard port (located just above the disk access) lets you connect a PC keyboard to the system.

**Note**

The access door must be closed and latched to maintain the NEMA seal.

**Warning**

To maintain a safe condition, you *cannot* use an external keyboard when the unit is operating in a hazardous environment.

<b>System Status LEDs</b>	The front panel features six status LEDs. Three are wired to hardware—Power, Disk, and COM. The remaining three—Maintenance, Fault, and RADAR—are programmable and can be accessed through Xycom’s LED/Status register. Refer to your Xycom CPU manual for more information on programming status LEDs.
---------------------------	---

## Back Panel

Figure Chapter 3 -2 illustrates the 9987 back panel components.

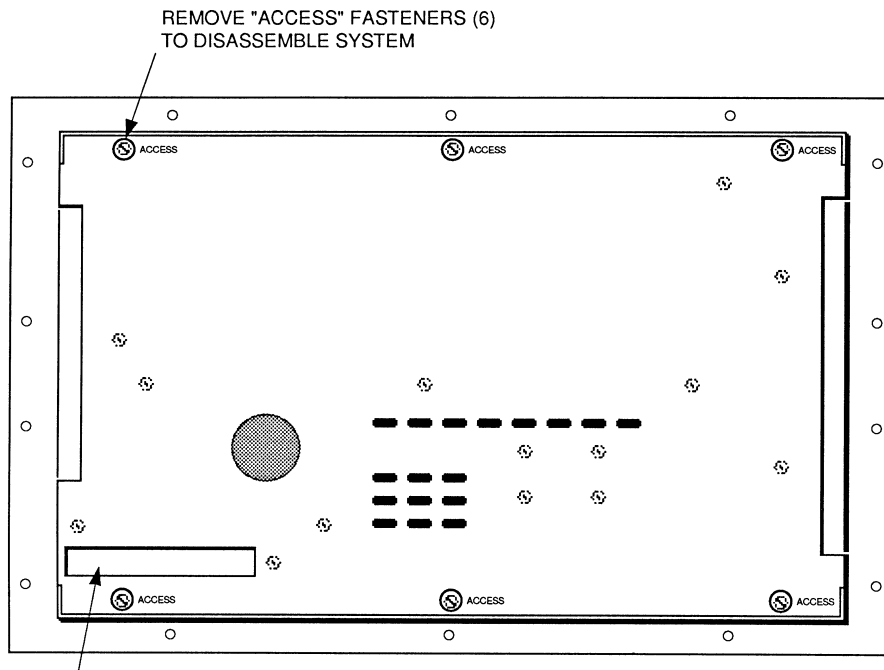

Figure Chapter 3 -2. 9987 Back Panel

<b>ACCESS Fasteners</b>	There are six fasteners located across the top and bottom of the back panel, each labeled ACCESS. When you remove these fasteners, you can remove the slide-out computer module.
<b>Floppy Disk Access</b>	You can configure the floppy disk drive for rear-panel access by removing the metal plate. This requires some disassembly and re-assembly.
<b>Product ID Label</b>	This label, located in the upper-left corner of the back panel, includes IDE hard drive setup information. A setup information label is also located on the hard disk casing.

## Power Panel

Figure Chapter 3 -3 illustrates the components on the left side of the 9987.

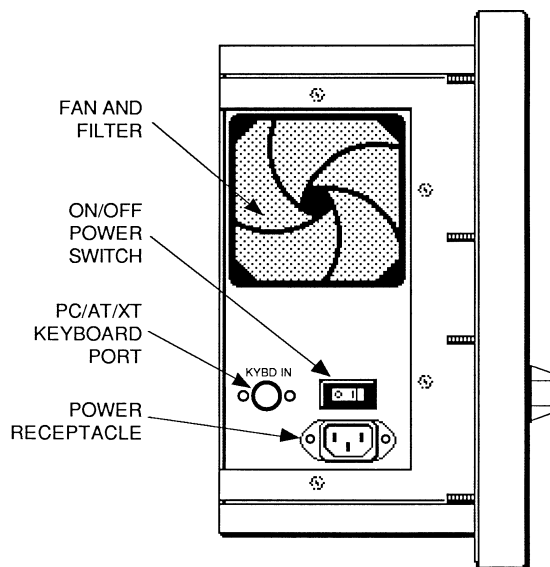

Figure Chapter 3 -3. 9987 Power Components

<b>On/Off Switch</b>	Position this switch to off (O) until the system is properly configured. (The switch is removed when configured for hazardous locations.)
<b>Power Receptacle</b>	The power receptacle is located below the On/Off switch. The plug and cord must be securely positioned before turning the power on. See <i>Hazardous Locations Installations</i> , later in this chapter, when configuring the system for hazardous locations.
<b>Keyboard Port</b>	Located to the left of the On/Off switch, the keyboard port allows a PC keyboard to be interfaced with the system. Do not use when in the presence of a hazardous environment.
<b>Fan and Filter</b>	The fan and filter are located above the keyboard port. The filter cover can be removed for cleaning.



## I/O Panel

Figure Chapter 3 -4 illustrates the I/O components on the right side of the 9987.

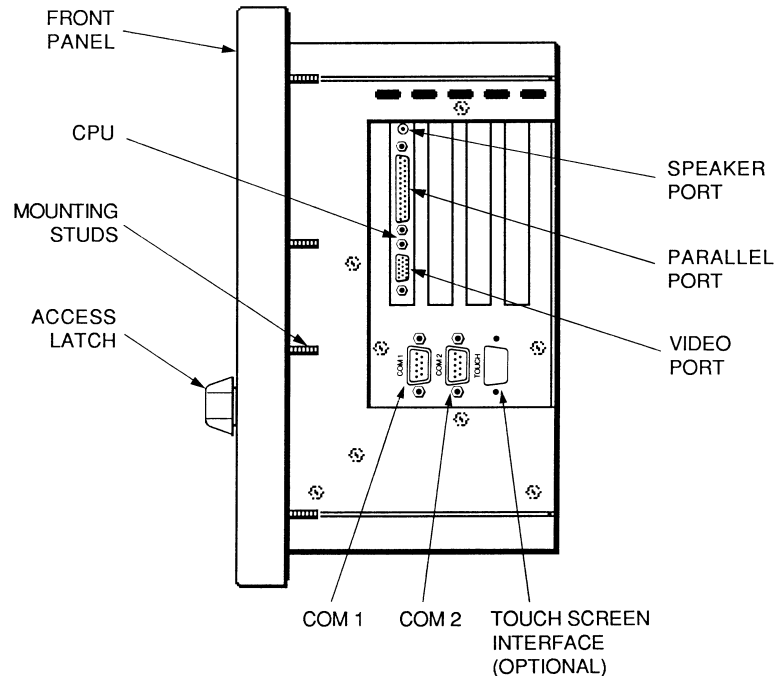

Figure Chapter 3 -4. 9987 I/O Components

<b>COM1/COM2 Ports</b>	The serial ports (RS-232) are DB-9 connectors located on the I/O panel below the CPU.
<b>Printer Port</b>	The parallel printer port (LPT1) is a 25-pin DB female connector located on the CPU.
<b>Video Port</b>	The video port – a 15-pin VGA connector located on the CPU board – is shipped disabled. To enable it, you must change the default switch settings, which will disable the flat-panel display. Refer to the switch settings on the label on the inside bottom of the front panel.
<b>Speaker Port</b>	The speaker port located on the CPU board is a subminiature phone jack protruding through the ORB.

Refer to Appendix C for pinout information.

## Preparing the System

To prepare the system for use, attach one end of the power cord to the power receptacle and the other to a properly grounded 90-250 VAC, 50-60 Hz outlet (see *Hazardous Locations Installations* within this chapter). If you have purchased any options, install them according to the instructions in the next two sections.

## Removing/Reconnecting the Slide-out Computer Module

The slide-out computer module, as shown in Figure Chapter 3 -5, allows access to the CPU boards and disk drives.

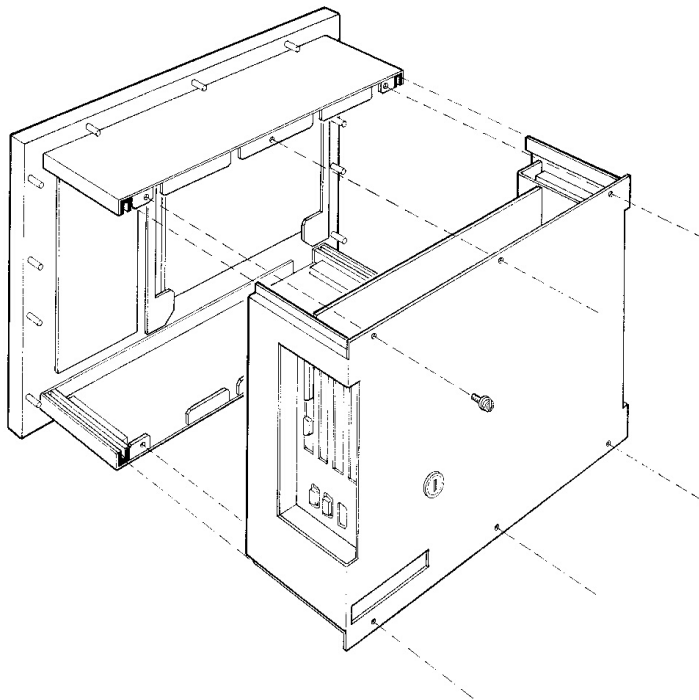

*Figure Chapter 3 -5. Slide-out Computer Module*

### Removing the Slide-Out Module

1. Remove the six ACCESS fasteners that attach the slide-out computer module to the 9987 back panel. (A 1/4-inch nut driver is needed to remove the 8/32 size fasteners.)
2. If the unit is not panel mounted, place it face down. Hold the front part down (located behind keypad) while pulling off the back panel to break the interconnect connection.
3. Grasp the handles that protrude from the back panel on the left and right sides, above the I/O inserts.
4. Pull straight back. The module should slide out easily.

## Reconnecting the Slide-out Module

### Note

If you are replacing the current module with a different module, refer to Table 5-1 for the correct switch settings. If the switch settings are incorrect, the Fault light blinks and the display will not light up.

After you have finished installing options on your 9987, reconnect it to the front panel according to the instructions below:

1. Match the top and bottom guides on the module with the slider indentations on the inside of the front panel shell, as illustrated in Figure Chapter 3 -5.
2. Push forward firmly until the top and bottom of the module are flush with the top and bottom of the front panel shell.
3. Reinsert the six ACCESS fasteners removed earlier.

## Installing Internal Hardware Options

### Caution

Turn off the unit before installing internal hardware.

To install internal hardware options, you first need to remove the slide-out module.

### 9000-RAD Card

You can install the 9000-RAD card if you have an open slot. Before installing the card (Solid State Disk) into the 9987, jumpers and switches must be set for your particular configuration. See the 9000-RAD manual for more information.

After the 9000-RAD is properly configured, it can be installed into the 9987 card cage as follows:

1. Unplug the 9987 from the AC wall outlet.
2. Remove the 9987 slide-out computer module (refer to the *Removing the Slide-Out Module* section earlier in this chapter). Set the six ACCESS fasteners aside for later use.
3. Verify jumper and switch settings. Refer to the 9000-RAD manual for the correct settings.
4. If present, remove the blank ORB from the slot that the 9000-RAD card will occupy. Save the screw.
5. Place the 9000-RAD card into the slots in the backplane. Push down on the card evenly, until it firmly seats into the card edge connectors.

6. Secure the 9000-RAD ORB to the host system by replacing and tightening the screw that was removed in Step 4.
7. Reconnect the computer module to the front panel and tighten the fasteners that were removed in Step 2.
8. Plug the 9987 into an AC wall outlet and turn on the power.

## **DRAM and Additional DRAM Single-Line Memory Modules (SIMMs)**

You can order your 9987 CPU factory-configured for many DRAM configurations. You can reconfigure the DRAM capacity by changing the DRAM SIMMs on your board. For more information, refer to the CPU manual.

## **Single-Slot PC Interface Module**

You can install a GE Fanuc Single-Slot PC Interface Module (PCIM) in your unit to access the Genius I/O system. The PCIM is available with up to two daughterboards, each of which serves as an I/O controller for the Genius I/O system. Each user-configurable board provides initialization and fault management for up to 30 bus devices. Refer to the PCIM documentation for installation instructions.

## **FloNet Interface Board**

You can also install a IPN200 FloNet interface board in your system. The FloNet board has two modes of operation: Ethernet and FloNet. In Ethernet mode, the board provides a standard Ethernet network interface with user-configurable hardware interrupts, I/O ports, and bootable ROM BIOS address location.

In FloNet mode, the FloNet board acts as the interface between a local host running FloPro software and an Ethernet LAN connected to at least one remote host platform running TCP/IP-compatible software. The on-board firmware constantly polls the Ethernet network interface waiting for packets where are intended to communicate with FloPro. The board will also process valid TCP/IP protocol packets.

When configured for FloPro mode, the FloNet board takes up to six eight-bit I/O ports, and 32 Kbytes of memory. When configured as an Ethernet card, the FloNet board takes an additional 16 I/O addresses. It may also take up an additional 32 Kbytes of memory space if configured to use a boot ROM.

Refer to the FloNet documentation for installation instructions.

## **Installing External Hardware Options**

This section explains how to install the external hardware options on the 9987.

## Extender Cable

The extender cable allows the 9987 to operate when the slide-out computer module is pulled out from the system enclosure. This cable connects between the two P2 and P3 connectors on the front panel and the interconnects on the backplane of the 9987.

### Caution

High voltages are present in the computer module when the extender cable is used. The extender cable should only be used for development and servicing. Do not leave the unit unattended when the extender cable is used.

1. Turn off the power.
2. Remove the slide-out computer module (refer to the *Removing the Slide-Out Module* section earlier in this chapter).
3. Connect the male end of the extender cable to the interconnects in the slide-out computer module.
4. Connect the female end of the extender cable to the P2 and P3 connectors inside the 9987 front panel, located on the PSIC board (refer to the system block diagram in Appendix B).
5. Turn on the power.

The computer module cannot be re-installed into the computer system with the extender cable connected. Before re-installing the computer module, turn off the power and disconnect the cable.

## Keyboards

Four keyboards are available for the 9987: the 8000-KB5, 8000-KB6, 8000-KB7, and 8000-KB8. Table Chapter 3 -1 lists the features of each keyboard.

Table Chapter 3 -1. Available Keyboards

Keyboard	Features
8000-KB5	A rack- or panel-mounted NEMA 4 104-key QWERTY keyboard with PC/AT interface
8000-KB6	A rack- or panel-mounted NEMA 4 numeric keyboard with 52 function keys
8000-KB7	A stand-alone 104-key QWERTY NEMA 4 keyboard.
8000-KB8	A stand-alone numeric NEMA 4 keyboard with 42 function keys

The keyboards are installed in the same way. Mount them according to the cutout in Appendix B. Once the keyboard is mounted, connect the cable to the keyboard port.

## Serial Mouse

To install Xycom's 4100-MS1 two-button serial mouse, attach the connector on the mouse cable to COM1 or COM2 on the side of the back panel.

## Installing Internal Options

### Operating Systems

If you want to install a new operating system or re-install a current operating system, refer to the operating system manual for instructions.

#### Note

The Windows NT operating system only ships on CD-ROM; it does not ship on floppy disk. Therefore, if Windows NT was preloaded on your system, you may have to purchase an external parallel port CD-ROM drive if you need to reinstall the operating system.

### 8X14 Font TSR

If an application does not display 8x14 characters correctly, you must install the TSR font file, found on the disk included with the documentation kit or on C:\VGA\CIRRUS.

To install this file, add the following line to your AUTOEXEC.BAT file:

```
TSRFONT.COM
```

Once you've added this line, you must reboot the system. For more information on editing the AUTOEXEC.BAT file, refer to the MS-DOS manuals.

#### Note

These instructions apply only to MS-DOS installations. If your system has the Windows 95 or Windows NT operating system, the 8x14 font TSR is installed in the operating system.

### Video Drivers

Video drivers are found on the disk included with the documentation kit (refer to the README file on this disk for information on unzipping the video drivers) or on C:\VGA\CIRRUS\WIN31.

For systems with AT5+ boards, the video drivers are found in the following directories: C:\VGA\C&T548\WIN or using either of the following extensions: \WINNT\OS2.

**Note**

These instructions apply only to MS-DOS installations. If your system has the Windows 95 or Windows NT operating system, the video drivers are installed in the operating system.

**Note**

Read the install.txt file in the OS2 subdirectory to create an OS2 driver disk.

## Sealed Durapoint Mouse Drivers

Xycom offers an optional sealed Durapoint mouse installed in the front panel floppy door. If you have purchased this option, a driver disk will be included with your system. This disk contains drivers that optimize the functionality of the Durapoint mouse for the MS-DOS, Windows 3.x, and Windows 95 operating systems.

## Creating a Custom Label

You have the option to place a custom label on the unit. Refer to Figure Chapter 3 -6 for the dimensions and recommended requirements for a customized label. Once you've obtained a customized label, place it over the "Xycom" in the upper left-hand corner of the front panel (inside the ring embossment).

**Note**

Material: .010 thk. Aluminum with .090 thick domes Epoxy resin on the front side and 3M #468 adhesive on the back side.

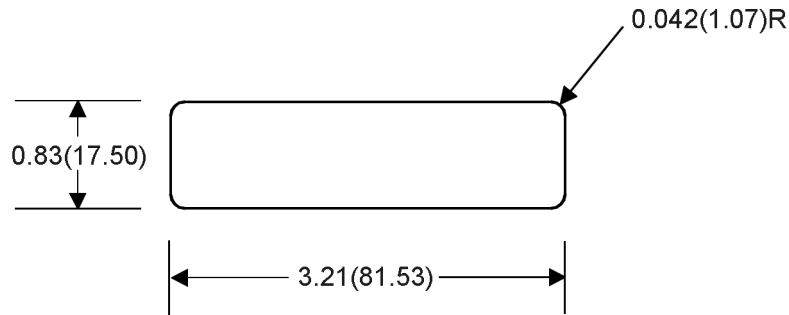

NOTE: All dimensions are in inches(mm)

Figure Chapter 3 -6. 9987 Logo Dimensions

## Installing the System into a Panel

The 9987's rugged design allows it to be installed in most industrial environments. The 9987 is generally placed in a NEMA 4/12 enclosure to protect against contaminants such as dust, moisture, etc. Metal enclosures also help minimize the effects of electromagnetic radiation that may be generated by nearby equipment.

## Mounting Considerations

### Note

A full-size mounting template can be obtained by contacting Xycom's Application Engineering Department.

Follow these guidelines when installing your 9987:

- Select an enclosure and place the unit to allow easy access to the 9987 ports and slide-out module.
- Account for the unit's depth when choosing the depth of the enclosure.
- Mount the 9987 in an upright position.

### Note

To ensure proper operation of the floppy drives, the manufacturer recommends that the unit be mounted within 25 degrees of an upright position.

- Place the 9987 at a comfortable working level.
- Consider locations of accessories such as AC power outlets and lighting (interior lighting and windows) for installation and maintenance convenience.



- Install a thermostat-controlled heater or air conditioner if condensation is expected.
- Avoid obstructing the air flow to allow for maximum cooling.
- Place any fans or blowers close to the heat-generating devices. If using a fan, make sure that outside air is not brought inside the enclosure unless a fabric or other reliable filter is used. This filtration prevents conductive particles or other harmful contaminants from entering the enclosure.
- Do not select a location near equipment that generates excessive electromagnetic interference (EMI) or radio frequency interface (RFI) (equipment such as high power welding machines, induction heating equipment, and large motor starters).
- Place incoming power line devices (such as isolation or constant voltage transformers, local power disconnects, and surge suppressors) away from the 9987. The proper location of incoming line devices keeps power wire runs as short as possible and minimizes electrical noise transmitted to the 9987.
- Make sure the location does not exceed the 9987's shock, vibration, and temperature specifications.
- Avoid overloading the supply circuit.
- Incorporate a readily accessible disconnect device in the fixed wiring for permanently connected systems.

## System Power

It is always a good practice is to use isolation transformers on the incoming AC power line to the 9987. An isolation transformer is especially desirable in cases in which heavy equipment is likely to introduce noise onto the AC line. The isolation transformer can also serve as a step-down transformer to reduce the incoming line voltage to a desired level. The transformer should have a sufficient power rating (units of volt-amperes) to supply the load adequately.

Proper grounding is essential to all safe electrical installations. Refer to the National Electric Code (NEC), article 250, which provides data such as the size and types of conductors, color codes, and connections necessary for safe grounding of electrical components. The code specifies that a grounding path must be permanent (no solder), continuous, and able to safely conduct the ground-fault current in the system with minimal impedance.

The following practices should be observed:

- Separate ground wires from power wires at the point of entry to the enclosure. To minimize the ground wire length within the enclosure, locate the ground reference point near the point of entry for the plant power supply.

- Ground all electrical chassis and machine elements to a central ground bus, normally located near the point of entry for the plant power supply of the enclosure. Paint and other nonconductive material should be scraped away from the area where a chassis makes contact with the enclosure. In addition to the ground connection made through the mounting bolt or stud, a one-inch metal braid or size #8 AWG wire can be used to connect between each chassis and the enclosure at the mounting bolt or stud.
- Properly ground the enclosure to the ground bus. Make sure a good electrical connection is made at the point of contact with the enclosure.
- For continued safety, connect machine ground to the enclosure and to earth ground.

## Excessive Heat

9987 systems are designed to withstand temperatures from 0° to 50° C. The systems are cooled by convection, in which a vertical column of air is drawn in an upward direction over the surface of its components. To keep the temperature in range, the cooling air at the base of the system must not exceed 50° C. Proper spacing must also be allocated between internal components installed in the enclosure. When the air temperature is higher than 50° C in the enclosure, use a fan or air conditioner.

## Excessive Noise

Electrical noise is seldom responsible for damaging components, unless extremely high energy or high voltage levels are present. However, noise can cause temporary malfunctions due to operating errors, which can result in hazardous machine operation in certain applications. Noise may be present only at certain times, may appear at widely spread intervals, or, in some cases, may exist continuously.

Noise usually enters through input, output, and power supply lines and may be coupled into lines electrostatically through the capacitance between these lines and the noise signal carrier lines. This usually results from the presence of high voltage or long, closely spaced conductors. When communication lines are closely spaced with lines carrying large currents, the coupling of magnetic fields can also occur. Use shielded cables to help minimize noise. Shielded communication cables should be grounded at the 9987 end only. Potential noise generators include relays, solenoids, motors, and motor starters, especially when operated by hand contacts like push buttons or selector switches. In accordance with National Electrical Code specifications, it is recommended that the high voltage and low voltage cabling be separated and dressed apart. In particular, the AC cables and switch wiring should not be in the same conduit with the PLC communication cables.

## Excessive Line Voltage

The power supply section of the 9987 is built to sustain line fluctuations of 90-250 VAC and still allow the system to function within its operating margin. As long as the incoming voltage is adequate, the power supply provides all the logic voltages necessary to support the processor, memory, and I/O.

In cases in which the installation is subject to unusual AC line variations, a constant voltage transformer can be used to prevent the system from shutting down too often. However, a first step toward the solution of the line variations is to correct any possible feed problem in the distribution system. If this correction does not solve the problem, a constant voltage transformer must be used.

The constant voltage transformer stabilizes the input voltage to the 9987 by compensating for voltage changes at the primary in order to maintain a steady voltage at the secondary. When using a constant voltage transformer, check that the power rating is sufficient to supply the 9987.

## Mounting the 9987

### Note

You can obtain a full-size mounting template by contacting Xycom's Application Engineering Department.

Once the conditions in the preceding sections have been met, follow the instructions below to mount the 9987:

1. Locate a position for your 9987 that meets the specifications required (see previous sections and Appendix A).
2. Create the cutout. Dimensions are shown in Figure Chapter 3 -7.

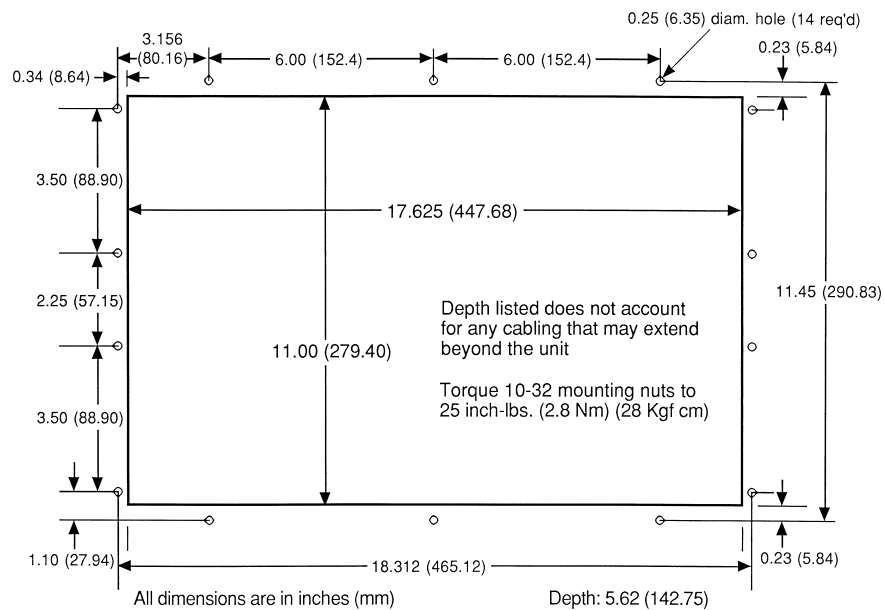

Figure Chapter 3 -7. 9987 System Cutout Dimensions

**Note**

A full-size template is available from Xycom's Application Engineering Department.

3. Make sure the area around the cutout is clean and free from metal burrs.
4. Implement the proper grounding techniques. Establish a ground path from the 9987 chassis to the enclosure chassis.

**Note**

To make a proper ground, scrape paint off the inside of the enclosure panel around the mounting stud holes (in at least two places) at opposing ends of the unit. This insures that a good electrical connection is made between the chassis and the grounded metal panel.

5. Detach the CPU module.
6. Install the monitor portion of the unit into the cutout.
7. Reattach the CPU module.
8. Tighten the 14 #10 nuts to 27 inch pounds.

## Installing PC/AT Boards

1. Check that the memory and I/O configuration of the board you want to install does not conflict with the CPU and I/O memory maps in your CPU board manual.
2. Remove the slide-out computer module.
3. Remove the ORB screw in the desired track.
4. Slide the PC/AT board into a corresponding rail.
5. Push the board into the backplane connectors.

**Note**

*Do not* force the boards or apply uneven pressure.

6. Secure the board by installing the screw through the hole in the board's metal ORB and into the top of the track.
7. Reconnect the slide-out computer module to the front panel (refer to the Removing the Slide-Out Module section earlier in this chapter).

**Note**

On systems with 133 and 200 MHz Pentium processors, the CPU may be moved to slot one to obtain a total of three expansion slots. If this is done, derate the temperature specifications by 5° C. Refer to Appendix A for temperature specifications.

## Installing the CPU into a Chassis

Following are the steps required to install the CPU into a chassis.

**Warning**

Disconnect all external power supplies before you open and service any piece of equipment. Also, always use static protection when handling CPU boards.

**Warning**

If the battery is disabled, when it is re-enabled the system must be powered up for a minimum of 30 seconds. Failure to follow this procedure may result in premature battery failure.

1. Disconnect all power supplies
2. Remove the slide-out computer module.
3. Verify all jumper settings as noted on the bottom of the front panel.
4. Place the CPU card into slot 0 (connectors JK7 and JK8) in the backplane. Push down on the card evenly, until it firmly seats into the card edge connectors.
5. Secure the ORB with one screw at the top.

**Note**

Not all of the following connections will be in every application. The installation instructions are geared toward an application using all of the CPU capabilities. Ignore those that do not apply.

**Caution**

Connectors can be connected backwards if you do not use keyed connectors. Ensure that the markings on the ribbon wire mate to pin 1 on both the board and the other component.

### Note

Before connecting a ribbon cable to latched connectors, make sure the latches are pulled halfway down. When the cable connection is made, the latches snap up. When removing a cable connector, move the latches down near the board. This ejects the connector so you can remove it easily.

6. Attach the floppy drive connector to FDD-2 by pulling out the tab on the board and sliding the end of the connector into it. Once the connector is inserted, push the top of the tab back in toward the board.
7. Attach the COM1 and COM2 connectors internally.
8. Attach any serial devices to COM1 or COM2 on the I/O panel.
9. Attach a printer to LPT1 (optional).
10. Plug an external speaker into SPKR (optional).
11. Plug the flat-panel cable into FPNL.
12. Reconnect the slide-out computer module to the front panel (refer to the Removing the *Slide-Out Module* section earlier in this chapter).
13. Connect the power sources.

The CPU is now ready for operation.

## Available Power

The power supply provides 80 watts of output throughout the 9987's temperature range. The expansion power is limited, as shown in Table Chapter 3 -2.

Table Chapter 3 -2. 9987 Available Current

Voltage	Available Current 486 Processors		Available Current Pentium Processors	
	Amps	Watts	Amps	Watts
+5 VDC	3.8	19	2.6	13
+12 VDC	3.2	38.4	3.2	38.4
-12 VDC	.45	5.4	.45	5.4
-5 VDC	.45	2.25	.45	2.25
<i>Total not to exceed 42 watts</i>			<i>Total not to exceed 35 watts</i>	

## Hazardous Locations Installations

Xycom offers an optional version of the 9987 with the intention of meeting the requirements of Class I, Division 2 Hazardous Locations applications.

These systems have been UL and CUL listed as non-incendiary devices. They are not intrinsically safe and should never be operated within a Division 1 (normally hazardous) location when installed as described here. Nor should any peripheral interface

device attached to these systems be located within Division 1 locations unless approved and/or certified diode barriers are placed in series with each individual signal and DC power line. Any such installations are beyond the bounds of Xycom design intent. Xycom accepts no responsibility for installations of this equipment or any devices attached to this equipment in Division 1 locations.

### Note

When adding cards, it is the customer's responsibility to ensure they meet operating conditions for Class I, Division 2 hazardous locations.

It is the responsibility of the customer to ensure that the product is properly rated for the location. If the intended location does not presently have a Class, Division, and Group rating, then users should consult the authorities having jurisdiction to determine what the correct rating for that hazardous location should be.

In accordance with federal, state/provincial, and local regulations, all hazardous locations installations should be inspected by the authority having jurisdiction prior to use. These systems are to be installed, serviced, and inspected only by technically qualified personnel.

## Safety Agency Approval

9987 systems are UL and CUL listed and have also been investigated for compliance with the following standards:

- *Underwriters Laboratories Inc., UL 1604 Standard for Safety*  
Electrical equipment for use in Class I and Class II, Division 2, and Class III hazardous (classified) locations
- Underwriters Laboratories Inc., UL 508  
Industrial Control Equipment
- *Canadian Standard Association, Specification C22.2 No. 213-M1987*  
Non-incendiary electrical equipment for use in Class I, Division 2 hazardous locations
- Canadian Standards Association, Specification C22.2 No. 14  
Industrial Control Equipment
- *UL File No. E180970*  
Suitable for use in Class I, Division 2 Groups A, B, C, and D, and Class II, Division 2, Groups F and G hazardous locations or non-hazardous locations only; operating temperature Code T4

### Warning - Explosion Hazard

Substitution of components may impair suitability for Class I, Class II, Division 2.

**Advertissment Risque D' Explosion**

La substitution de composants peut rendre ce materiel inacceptable pour les emplacements de classe I, II, Division 2.

**Warning - Explosion Hazard**

Do not disconnect equipment unless power has been switched off or the area is known to be non-hazardous.

**Advertissment Risque D' Explosion**

Avant de deconnecter l'equipment, coupler le courant ou s'assurer que l'emplacement est designe non dangereux.

**Warning**

Explosion hazard—batteries must only be changed in an area known to be non-hazardous.

**Warning - Explosion Hazard**

When in hazardous locations, turn off power before replacing or wiring modules.

**Advertissment Risque D' Explosion**

Dans les situations hasardees, couper la courant avant de remplacer ou de cabler les modules.

**Warning**

To maintain a safe condition, an external keyboard must *not* be used when the unit is operating in a hazardous environment.

**Definitions**

The following Class and Division explanations are derived from Article 500 (Sections 5 and 6) of the United States National Fire Protection Agency National Electric Code (NFPA 70, 1990). They are not complete and are included here to provide a general description for those not familiar with generic hazardous locations requirements.



Persons responsible for the installation of this equipment in hazardous locations are responsible for ensuring that all relevant codes and regulations related to location rating, enclosure, and wiring are met.

### **Class I Locations**

Class I locations are those in which flammable gases or vapors are or may be present in the air in quantities sufficient to produce explosive or ignitable mixtures.

### **Class II Locations**

Class II locations are those that are, or may become, hazardous because of the presence of combustible dust.

### **Division 1 Locations**

A Division 1 location is one in which flammable or ignitable gases, vapors, or combustible dusts and particles can exist due to the following:

- Normal operating conditions
- Because of repair, maintenance conditions, leakage, or where mechanical failure or abnormal operation of machinery or equipment might release or cause explosive or ignitable mixtures to be released or produced
- Combustible dusts of an electrically conductive nature may be present in hazardous quantities

#### **Note**

9987 systems are not suitable for installation within Division 1 locations.

#### **Note**

Electrical equipment cannot be installed in Division 1 locations unless it is intrinsically safe, installed inside of approved explosion-proof enclosures, or inside of approved purged and pressurized enclosures.

### **Division 2 Locations**

Division 2 locations are listed below:

- Class I volatile flammable liquids or flammable gases are handled, processed, or used, but confined within closed containers or closed systems from which they can escape only in cases of accidental rupture or breakdown of such enclosures or systems, or in case of abnormal operation of equipment.
- Ignitable concentrations of Class I vapors or gases are normally prevented by positive mechanical ventilation, but which may become hazardous due to mechanical failure of those ventilation systems.

- Location is adjacent to a Division 1 location.
- Class II combustible dust is not normally in the air in quantities sufficient to produce explosive or ignitable mixtures. Dust accumulations are normally insufficient to interfere with normal operation of electrical equipment or other apparatus. Combustible dust may be in suspension in the air as a result of the following: infrequent malfunctioning of handling or processing equipment; combustible dust accumulations on, or in the vicinity of electrical equipment; may be ignitable by abnormal operation or failure of electrical equipment.

## Groups

All electrical equipment approved for use in hazardous locations must include a group rating. Various flammable and combustible substances are divided into these groups as a function of their individual maximum experimental safe gap (MESG), explosion pressure, and ignition temperature.

Component temperatures and the potential for spark based upon voltage, current, and circuit characteristics within electrical equipment determines the equipment group rating. A device approved for installation within Class I, Group A locations may also be used in Groups B, C, or D.

### Note

Approved Class I equipment may not be suitable for Class II installations. Class I includes Groups A, B, C, and D. Class II includes Groups F and G.

## Enclosures

9987 systems are designed for installation within a clean and dry enclosure for both ordinary and hazardous locations. The front panel meets the requirements of UL and CSA Type 4, 4X, and 12 enclosures. The enclosure used for Class I hazardous locations should have a minimum rating of Type 12 (NEMA 12, IP 5X). However, Type 4 (IP 6X) enclosures are strongly recommended.

### Warning

The floppy disk/keyboard port access door must be closed and latched at all times to maintain a proper seal against water and dust.

Panel flatness and rigidity are important if a proper panel seal is to be maintained. If non-metal type enclosures, such as plastic or fiberglass, are used, install a rigid metal stiffener behind the front panel. Failure to do so may result in an inadequate panel seal due to flexure of the front panel material between the stud mounts. The nuts on the mounting studs must be tightened to 25 inch-pounds.

These systems are UL listed for installation within Class II locations only when installed within UL approved Type 4 enclosures. Failure to do so voids that UL listing.

The requirements for enclosure fittings, conduit, and wiring vary according to the specific rating of the location and the type of flammable or combustible material involved. Those requirements are beyond the scope of this document and it is the responsibility of the customer to ensure that their installation is compliant with codes and regulations which apply to their specific location. Reference NFPA 70, Article 500 for specific regulations in the United States.

## Power Switch

A 9987 system that will be used in a hazardous location does not have a power switch. The amount of input power required by these systems classifies the power switch as an incendiary device. That is, the voltage and current across the make/break device is capable of creating a spark.

Hazardous locations regulations require that a power switch rated for ordinary locations may be used if it is located in an area specified as non-hazardous. However, limits in cable length between the workstation and the power switch may apply. Otherwise the switch must be compliant with Class I, Division 1 requirements (intrinsically safe). These switches are built in a manner that prevents the possibility of a spark when contacts are made or broken.

Suitable UL listed and/or CSA Certified Class I, Division 1 switches must be used in hazardous locations. These switches are available from a number of sources. It is the responsibility of the customer to ensure that the power switch selected for the installation has the correct hazardous locations rating for the location in which it is installed.

## Cable Connections

Division 2 hazardous locations regulations require that all cable connections be provided with adequate strain relief and positive interlock. A cable should never be connected or disconnected while power is applied at either end of the cable.

### Power Cable Connection

The power cable supplied with units configured for use in hazardous locations are UL Listed Type SJT 3 conductor, 18AWG cord sets. The system is supplied with a connector clamp that securely fastens the female connector to the unit.

#### **Warning–Explosion Hazard**

Failure to securely fasten this connector clamp voids the UL listing for use in hazardous locations.

Plug the cable's female plug into the AC power receptacle on the system's left side. Using the supplied offset screwdriver, tighten the clamp securely around the plug.

The other end of the cable requires field termination to the incoming AC power line. The cord may be shortened for optimal length. Strip 3.0 inches (76 mm) of outer

jacket insulation from the three conductors. The three conductors—L1 (Hot/White), L2 (Blue/Neutral), and PE (Protective Earth Ground/Green-Yellow)—should be stripped to expose 0.25 inches (6 mm) of wire. A small amount of solder should be applied to these ends to prevent loose strands of wire from being bent back and accidentally shorting to adjacent leads. These three leads should be securely fastened to their corresponding incoming lines.

### **Communication Cable Interface**

All communication cables should include a chassis ground shield. This shield should include both copper braid and aluminum foil. The D-sub style connector housing should be a metal conductive type (e.g., molded zinc) and the ground shield braid should be well terminated directly to the connector housing. Do not use a shield drain wire.

The outer diameter of the cable must be suited to the inner diameter of the cable connector strain relief to maintain a reliable degree of strain relief. The D-sub connectors must always be secured to the 9987 workstation mating connectors via the two screws located on both sides.

#### **Warning**

The communication cables should never be connected or disconnected while power is applied at either end of the cable. This may result in an incendiary spark. Furthermore, permanent damage to the workstation communication components may occur.

## **Operation and Maintenance**

9987 systems have been investigated for compliance with relevant spark ignition tests by UL. However, please note that the workstation front panel membrane keyboard keys and keyboard connector are the only make/break components intended to be exercised by the operator in the course of normal operation.

#### **Warning**

To maintain a safe condition, an external keyboard must not be used when the unit is operating in a hazardous environment.

With respect to hazardous locations installations, the following rules must always be observed:

- Always install the workstation within an enclosure suitable for the specific application. General purpose enclosures may be acceptable for Class I applications but are never acceptable for Class II applications. Type 4 (IP 65) enclosures are recommended even when not required by regulations.
- If present, keep enclosure doors or openings closed at all times to avoid the accumulation of foreign matter inside the workstation.

- Never subject the unit to any installation or service procedures unless power is removed and the area is non-hazardous. This includes the installation or removal of power cables, communication cables, or removal of the rear cover of the unit.
- Installation and service should only be performed by technically qualified service personnel. These workstations are designed to require no service in the course of normal operation by an operator.

# Chapter 4 – Programmable Keyboard Interface Module

---

The 9987's front panel integrates a programmable keyboard interface module (PKIM) circuit. This lets users redefine all keypad keys with new scan codes using PKIM utility software.

An external full-stroke PC/AT keyboard is used to access the PKIM utility. (This keyboard is not redefinable.)

## Note

While the PKIM utility is running, the keypad switch arrays are disabled.

## Loading the PKIM Utility

The PKIM utility can be run from the disk or copied onto your hard drive. To run the utility from the disk, change the directory to the appropriate drive and type PKIM. To load the PKIM utility onto your hard drive, create a subdirectory for the files, and copy all the files on the disk into that subdirectory. Enter the subdirectory and type PKIM.

## Using the PKIM Utility

The PKIM utility uses a menu bar and pull-down menu system. All menu bars are displayed across the top of the screen. "Xycom PKIM Utility" and the current menu title are shown at the bottom of the screen (see Figure Chapter 4 -1).

A full stroke keyboard is needed to enter keystrokes while recording a new key macro, editing an existing macro, and entering utility commands. All keys on the keypads are redefinable. While the utility is running, the keypads are disabled.

Dialog boxes appear for user prompts and to display error and user advice messages.

Two keys can be used to exit from the menus:

- ESC moves to the previous menu or out of the utility from the Main Menu.
- F1 returns to the current menu headings in some of the menus where Exit can be chosen to exit this menu.

The keys specific to each menu are shown at the bottom of each screen.

## PKIM Startup

This section describes the startup options for the PKIM utility.

**PKIM** [/r | /t]           Runs the full PKIM utility

Where:

- /r     =    Reduced functionality. Some keyboard controllers will not allow the PKIM utility to have control. In this case, keycodes uploaded from the EEPROM cannot be translated correctly. Starting the PKIM utility with the /r switch removes the Upload option from the Main Menu. In this mode, editing must start with macros read in from a file since they cannot be read from EEPROM.
- /t     =    Translate. Some systems initialize the keyboard to run in XT mode. In this case, the scan codes read in from the keyboard when in Teach mode will not be correct unless the PKIM utility is started with the /t switch.

## PKIM Utility Batch Mode

Versions 2.2 and above of the PKIM utility include a mode for reprogramming keypads from a batch file. This feature is useful if you wish to reprogram many units with customized keypad macros without having to enter the full PKIM utility for each unit. Once the full utility has been used to create and save keypad macros, the files containing these macros can be included on a disk with the PKIM utility and then used to reprogram other units from a batch file.

**PKIM filename**           Runs the PKIM utility batch mode where filename is the file containing the new keypad macros. The filename extension must be included. For example, in a batch file PKIM nudef32.pkm would reprogram the default values for the numeric keypad.

You may also specify multiple macro filenames in the PKIM line. For example, PKIM nudef32.pkm 20funcff.pkm will reprogram both the numeric and the function key keypads.

## Main Menu

The main menu provides six selections: Exit, Files, Macros, Upload, Download, and Utilities. Figure Chapter 4 -1 depicts the Main Menu.

Exit	Files	Macros	Upload	Download	Utilities
Xycom PKIM Utility: MAIN L-Arrow, R-Arrow, Enter					

Figure Chapter 4 -1. PKIM Main Menu

Each of the Main Menu selections is described in separate sections below. Choices from the menu are discussed in the order they appear on the screen.

## Exit

Exit closes open files and exits the utility. ESC can also be used for this purpose and for exiting the other menus.

## Files Menu

Files containing keypad macro sets (a macro for each key) may be saved on disk and loaded into memory to view, edit, or download to the PKIM. Some of these files may be included in the utility package for use in reconfiguring the keypads for different software packages and as templates for defining completely new keypad macro sets.

When you choose Files, a drop-down menu displays the following choices:

- Open**      Opens a file that contains a macro set for one of the keypads and loads the contents into memory. Any macro set previously in memory is overwritten. Once loaded, the macro set is available to edit, view, teach, and/or download to the PKIM.
- Close**     Clears the macros from memory and closes the file from which they came.
- Save**       Copies the set of macros from memory back into their original file. The original file contents are overwritten.
- Save As**    Creates a new file under the specified name and copies the set of macros from memory into it. For example, to define different sets of codes, save each set under a different name and download the one you wish to use.



- Delete** Deletes a file.
- Exit** Returns to the Main Menu.

## Macros Menu

When Macros is selected, a menu bar displays four choices: Exit, View, Teach, and Edit.

### Note

You must have a macro file in memory before the Macros Menu is available. To load a macro file, Open or Upload a file.

- Exit** Returns to the Main Menu.
- View** Allows viewing the macro for the selected key without having to worry about an accidental change to the macro. When View is chosen, the Exit option and the state of the click (clicks are not supported on the 9987) are displayed on the menu bar and a graphic representation of the chosen keypad is shown. Select Exit from the View Menu to return to the Macros Menu.
- To select a key to view, use the arrow keys to position the cursor on the desired key and press ENTER.

The macro is displayed as two lines ASCII and code. The ASCII line displays each keycode as the keys it represents on the full stroke keyboard. Special labels are used for certain keys (e.g., Spc for space bar, UAr for up arrow, and bk for the break code prefix). The code line is displayed in either hex or decimal, as explained below. There is a one-to-one correspondence between the ASCII and code lines to help you interpret the code line.

The menu bar displayed while viewing the macro offers two options: Exit and Hex/Decimal.

- Exit** Returns to View menu.
- Hex/Decimal** Toggles between displaying the macro in hex or decimal format. Default is Hex. When Hex is chosen, the keycodes are displayed as they are in memory hexadecimal value scan codes. When Decimal is chosen, the keycodes are displayed as the decimal equivalent of the hex codes.

For example, the macro **abc** would be displayed as 1C F0 1C 32 F0 32 21 F0 21 in hex, and 28 240 28 50 240 50 33 240 33 in decimal.

- Teach** Allows you to record key strokes into a macro. When Teach is selected, a graphic representation of the keypad currently in memory is displayed. Menu bar choices are Exit, ASCII/Hex/Decimal, and Click ON/OFF.
- Exit** Returns to Macros menu.

**ASCII/Hex/Decimal** Chooses the format to display the keystrokes as they are entered. Default is ASCII.

**Click ON/OFF** Not supported on the 9987.

To select a key to define, use the arrow keys to position the cursor on the desired key and press ENTER. After a key is selected, the utility records every key stroke on the external full stroke keyboard into a macro to be assigned to the chosen key. As the keys are entered they are displayed using the chosen format. ESC is used to stop recording and return to the Teach Menu, so it is not a recordable key. However, ESC can be included in a macro by using the editor.

**Note**

The changes made to the macros in the Teach Menu are not programmed until you select Download.

**Edit** Displays a graphic representation of the keypad in memory and a menu bar displaying Exit and Click ON/OFF.

**Exit** Returns to the Macros Menu.

**Click ON/OFF** Not supported on the 9987.

To select a key to edit, use the arrow keys to position the cursor on the desired key and press ENTER.

In edit mode, the macro is displayed as two lines. The top line (the edit line) displays the macro in either hex or decimal format and is the line in which the actual editing takes place. The bottom line (the ASCII line) displays the macro in ASCII format and is not user configurable. This line helps keep track of which part of the macro you are editing, and will be updated by the utility as editing takes place.

For example:

```
edit line-> 12 75 F0 75 F0 12 1C F0 1C 12 22 F0 22 F0 12 0
ASCII line-> sh 8 bk 8 bk sh a bk a sh X bk X bk sh EOM
```

The insert, delete, and cursor control keys are active for editing.

When a key is selected, the menu bar displays the following choices: Exit, Cut, Copy, Paste, Codes, Hex/Decimal, and I/O (Insert/Overtyp). The macro for the chosen key is also displayed.

**Exit** Returns to the Edit Menu.

**Cut** Deletes a sequence of scan codes from the macro. To select a section to cut:

Place the cursor on the first character to cut.

Press F1 and select Cut.

Press ENTER. Cut should still be highlighted, but the cursor will appear on the Edit line. Place the cursor on the last character to cut and press ENTER.

The last character of every macro is the end of the macro (EOM) and cannot be deleted.

**Copy**

Copies a sequence of scan codes from the macro into memory. To select the section to copy:

1. Place the cursor on the first character to copy.
2. Press F1 and select Copy.
3. Press ENTER. Copy should still be highlighted, but the cursor will appear on the Edit line.
4. Place the cursor on the last character to copy and press ENTER.
5. The copied item does not appear on the screen until you select Paste.

**Paste**

Inserts a sequence of scan codes (which were saved in memory using Copy) into the macro. To paste a sequence of scan codes that were previously copied, position the cursor where you want the text to appear and then press F1. Select Paste and then press ENTER.

**Codes**

Displays a table of keys and their scan codes in hex.

**Hex/Decimal**

Toggles between displaying the scan codes in hex and decimal formats.

**I/O**

Toggles the insert key between insert and overwrite mode.

## Upload Menu

Use the Upload Menu to choose which keypad macro information to load. The menu choices are defined below:

<b>Function Keypad</b>	Commands the PKIM to send its entire macro set for the function key keypad
<b>Numeric Keypad</b>	Commands the PKIM to send its entire macro set for the numeric key keypad
<b>Keyboard</b>	Commands the PKIM to send its entire macro set for the switch array keyboard. (The 9987 does not support the ability to reprogram switch array keyboards. You may choose to upload a keyboard, but the keys will not be defined.)
<b>PKIM version</b>	Commands the PKIM to send its firmware revision number
<b>Exit</b>	Returns to the Main Menu

### Note

Only one macro set may reside in memory at one time. Also, Upload is not available if the utility is started with the /r switch.

A checksum will be calculated during transmission and an error message displays if an error occurs.

## Download Menu

### Caution

Any macro set previously programmed is overwritten when you select Download.

Download sends the set of keypad macros to the PKIM. The macro set must reside in memory before you can download it. During transmission, a checksum is calculated, and an error message displays if an error occurs.

As the macro is sent, PKIM programs its EEPROM with the new macros which become the new key definitions for the selected keypad.

## Utilities Menu

When you select Utilities, a menu bar displays the following menus:

<b>Func Lock ON</b>	Turns on the function key interlock feature. The function key interlock disables all function keys as long as one function key is pressed (only one function key can be activated at one time).
---------------------	---

<b>Func Lock OFF</b>	Turns off the function key interlock feature, allowing multiple function key presses
<b>Clear EEPROM</b>	Erases the EEPROM memory. This clears the set of keypad macros, the contrast setting, the backlight timeout setting, and the function key interlock setting. After using this feature, turn the unit off and then on. This initializes the EEPROM with the default settings.
<b>Exit</b>	Returns to the Main Menu

## Codes

Special PKIM codes replace the standard IBM scan codes for 101-key keyboard enhanced keys in macros that use these keys. The special scan codes are listed in Table Chapter 4 -1.

*Table Chapter 4 -1. Special PKIM Scan Codes*

<b>Code</b>	<b>Meaning</b>
E2	Insert
E3	Home
E4	Page Up
E5	Delete
E6	End
E7	Page Down
E8	Up Arrow
E9	Left Arrow
EA	Right Arrow
EB	Down Arrow
EC	Forward Slash
ED	Print Screens/Sys Rq
EE	Pause/Break

Table Chapter 4 -2 defines the hex scan codes used by the PKIM utility.

Table Chapter 4 -2. Hex Scan Codes

Key	Code	Key	Code
A	1C	[/{	54
B	32	]}	5B
C	21	;/:	4C
D	23	'"	52
E	24	./<	41
F	2B	./>	49
G	34	//?	4A
H	33	'~	OE
I	43	-/_	4E
J	3b	=/+	55
K	42		5D
L	4B	F1	05
M	3A	F2	06
N	31	F3	04
O	44	F4	0C
P	4D	F5	03
Q	15	F6	0B
R	2D	F7	83
S	1B	F8	0A
T	2C	F9	01
U	3C	F10	09
V	2A	F11	78
W	1D	F12	07
X	22	Back Space	66
Y	35	Enter	5A
Z	1A	Shift Right	59
0/)	45	Shift Left	12
1/!	16	Caps Lock	58
2/@	1E	Alt Left	11
3/#	26	Ctrl Left	14
4/\$	25	Tab	0D
5/%	2E	Space	29
6/^	36	ESC	76
7/&	ED	Num Lock	77
8/*	3E	Home/7	6C
9/(	46	Up Arrow/8	75
+	79	Page Up/9	7D

Table Chapter 4 -2 continued on following page)

*Table Chapter 4 -2. Hex Scan Codes (continued from previous page)*

<b>Key</b>	<b>Code</b>	<b>Key</b>	<b>Code</b>
Ins/0	70	Left Arrow/4	6B
Del/	71	/5	73
Scroll Lock	7E	Right Arrow/6	74
*	7C	-	7B
Alt r	E0 11	End/1	69
Ctrl r	E0 14	Down Arrow/2	72
Ent k	E0 5A	Page Down/3	7A
Break	F0		

# Chapter 5 – Maintenance

---

The 9987 was designed to withstand the harsh environment of the factory floor. Routine maintenance can keep your 9987 in good operating condition. Preventive maintenance consists of several basic procedures that will greatly reduce the chance of system malfunction. Preventive maintenance should be scheduled along with the regular equipment maintenance to minimize 9987 down time.

## Preventive Maintenance

Some preventive measures are listed below.

- Clean or change the fan filter periodically to ensure that the air circulating in the unit is clean. Wash the filter with warm water and dish soap, and let it air dry. Do not scrub the filter, and do not re-install it into the unit until it is completely dry.
- Base your maintenance schedule on the type of environment the system is in (i.e., if the area is dusty, you should schedule maintenance more often than if it is a dry, clean area). Also, check the filter often to determine if it needs to be changed ahead of schedule.
- Remove dust and dirt from PC components. If dust builds up on heat sinks and circuitry, an obstruction of heat dissipation could cause the unit to malfunction. If dust reaches the electronic boards, a short circuit could occur.
- Check the connections to I/O modules, especially in environments where shock could loosen the connections. Check to see that all plugs, sockets, terminal strips, and module connections are solid.
- Do not place unnecessary articles, such as drawings or manuals, on the unit. They could obstruct air flow and create hot spots, which cause the system to malfunction.
- Do not place noise-generating equipment near the 9987.
- Stock spare parts to minimize down time resulting from part failure. The spare parts stocked should be 10 percent of the number of each unit used. Main CPU cards should have one spare each. Each power supply should have a backup. In certain applications where immediate operation of a failed system is required, an entire spare computer module may need to be stocked. See the Spare Parts List later in this chapter.
- Make sure the module is the correct type when replacing. If the new module solves the problem but the failure reoccurs, check for inductive loads that may be generating voltage and current spikes and may require external suppression.

## Routine Maintenance

This section describes routine maintenance you can do on the 9987.



## Replacing the Fuse

### Warning

Turn off power to the terminal before removing the fuse.

The 9987 uses a 5 amp 3AG 250 volt fuse. The fuse holder is located on the power supply. Grasp the fuse (or place an object such as a pen or pencil behind it) and pull it toward you. It should snap out of the holder. Replace the fuse by placing it sideways against the holder and pushing it away from you until it snaps into place.

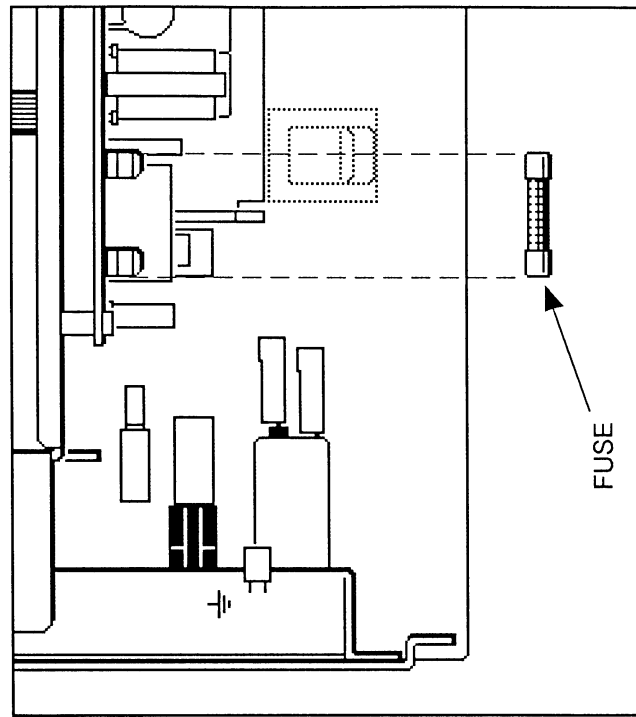

Figure Chapter 5 -1. Fuse Holder

## Replacing the Slide-out Computer Module

Refer to Chapter 3 for information on reconnecting the slide-out computer module.

### Caution

The switch settings on the CPU board *must* match those listed on the label found at the bottom of the front panel.

Table Chapter 5 -1 lists the switch settings for color flat-panel displays:

*Table Chapter 5 -1. AT Processor Switch Settings*

Monitor	SW1-1	SW1-2	SW1-3	SW1-4	SW1-5	SW1-6	SW1-7	SW1-8
Color TFT	Closed	Closed	Closed	Open	Closed	Closed	Open	Open

If SW1-5 through SW1-8 do not match the label on the front panel, the Fault LED will blink to signal a mismatch. A blinking Maint LED indicates a communication failure between the CPU and the PKIM.

## Replacing the Fan Filter

To change the fan filter, remove it as illustrated in Figure Chapter 5 -2. Clean the filter and snap the grill back into position.

### Caution

Do not operate the 9987 without a fan filter. Dust build-up could cause the unit to malfunction.

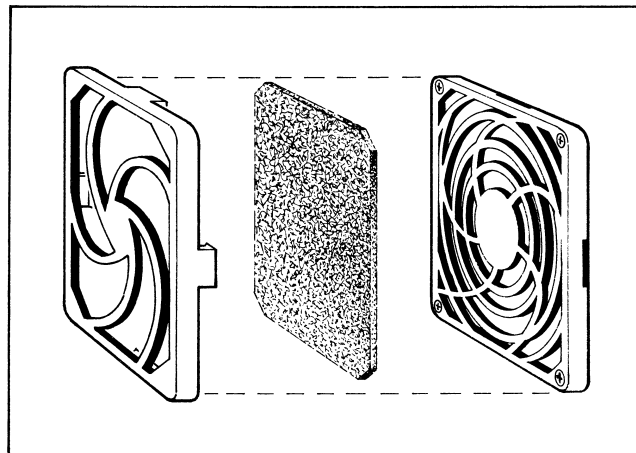

*Figure Chapter 5 -2. Changing the Fan Filter*

## Spare Parts List

Following is a list of available 9987 replacement parts. To order, contact the Xycom Customer Service department at 1-800-289-9266 or 1-734-429-4971.

- Front Panel Assembly\*
- Replacement Bulb Assembly\*

### \*Note

As flat-panel display technology changes rapidly, please provide Xycom Customer Service with a model number if you need to purchase a replacement part for a display (display, bulb, or inverter). This model number is located inside the unit, on the display itself.

- CPU (specify clock speed)
  - AT4+, 0 Mbytes
  - AT5+, 0 Mbytes
- DRAM
- Extender cable
- Fan filter/guard
- Drives (specify drive size)
  - Floppy drive
  - Hard drive
  - Solid State (FLASH) drive
- Keypads
  - F1-5
  - F6-10
- Orb, blank
- PSIC card
- Power supply

## Product Repair Program/Returning a Unit to Xycom

Xycom's Product Repair & Customization Department (PR&C) restores equipment to normal operating condition and implements engineering changes that enhance operating specifications. Products returned to Xycom will be tested with standard Xycom test diagnostics.

Follow the steps below to prepare the unit for shipment:

1. Obtain an RMA number for your unit by calling the nearest Xycom repair center. Have the following information available:
  - Company name, and shipping and billing address

- Type of service desired—product repair or product exchange
  - Product model number, part number, quantity, serial number(s), and warranty status
  - Failure mode and failure systems
  - Purchase order number or repair order number
  - Make sure the front panel assembly is properly attached to the unit and the slide-out computer module is secured by all six ACCESS fasteners
2. To speed processing, attach failure information to the unit.
  3. Place the unit securely in a heavy-duty box.
  4. Mark the RMA number on your purchase order and on the outside of the box.
  5. Send the unit to the nearest Xycom repair center.

# Appendix A – Technical Specifications

Table Appendix A -1. Hardware Specifications

Characteristic	Specification												
Mechanical													
Height	12.2" (310 mm)												
Width	19" (483 mm)												
Depth	5.62" (143 mm)												
Weight	27 lbs (12.2 kg)												
Electrical	<b>90-250 VAC</b> 2.1 A maximum 47-63 Hz												
Power Supply	110 watts												
Passive Backplane	Four full-length PC/AT slots												
Available Power	<table border="0"> <tr> <td><b>486 Processors</b></td> <td><b>Pentium Processors</b></td> </tr> <tr> <td>+5 VDC @ 3.8 A</td> <td>+5 VDC @ 2.6 A</td> </tr> <tr> <td>+12 VDC @ 3.2 A</td> <td>+12 VDC @ 3.2 A</td> </tr> <tr> <td>-5 VDC @ .45 A</td> <td>-5 VDC @ .45 A</td> </tr> <tr> <td>-12 VDC .45 A</td> <td>-12 VDC @ .45 A</td> </tr> <tr> <td><i>Total not to exceed 42 watts</i></td> <td><i>Total not to exceed 35 watts</i></td> </tr> </table>	<b>486 Processors</b>	<b>Pentium Processors</b>	+5 VDC @ 3.8 A	+5 VDC @ 2.6 A	+12 VDC @ 3.2 A	+12 VDC @ 3.2 A	-5 VDC @ .45 A	-5 VDC @ .45 A	-12 VDC .45 A	-12 VDC @ .45 A	<i>Total not to exceed 42 watts</i>	<i>Total not to exceed 35 watts</i>
<b>486 Processors</b>	<b>Pentium Processors</b>												
+5 VDC @ 3.8 A	+5 VDC @ 2.6 A												
+12 VDC @ 3.2 A	+12 VDC @ 3.2 A												
-5 VDC @ .45 A	-5 VDC @ .45 A												
-12 VDC .45 A	-12 VDC @ .45 A												
<i>Total not to exceed 42 watts</i>	<i>Total not to exceed 35 watts</i>												
Mounting	EIA standard 19" panel												
Flat Panel	10.4" TFT high-brightness CCFT color display												
Agency Approvals	UL 508, (1604 if configured for hazardous locations) CUL C22.2 No. 14, (213 if configured for hazardous locations) TUV EN 60950												

Table Appendix A -2. Environmental Specifications

Characteristic	Specification
Temperature Operating Non-operating	0° to 50° C (32° to 122° F) -20° to 60°C (-4° to 140°F) <i>Note: On 133 and 200 MHz systems with Pentium processors, the CPU may be moved to slot one to obtain a total of three expansion slots. If this is done, you must derate the temperature specifications by 5° C.</i>
Humidity Operating Non-operating	20% to 80% RH non-condensing 20% to 80% RH non-condensing
Altitude Operating Non-operating	Sea level to 10,000 feet (3048 m) Sea level to 40,000 feet (12192 m)
Shock (with no rotating media) Operating Non-operating	15 g peak acceleration 11 msec duration 30 g peak acceleration 11 msec duration
Vibration (with no rotating media) Frequency Operating Non-operating	5 to 2,000 Hz .006" (.15 mm) peak-to-peak displacement 1.0 g (maximum) acceleration .015" (.38 mm) peak-to-peak displacement 2.5 g (maximum) acceleration
Front panel impact specification	Designed to meet UL1418

# Appendix B – Block Diagram

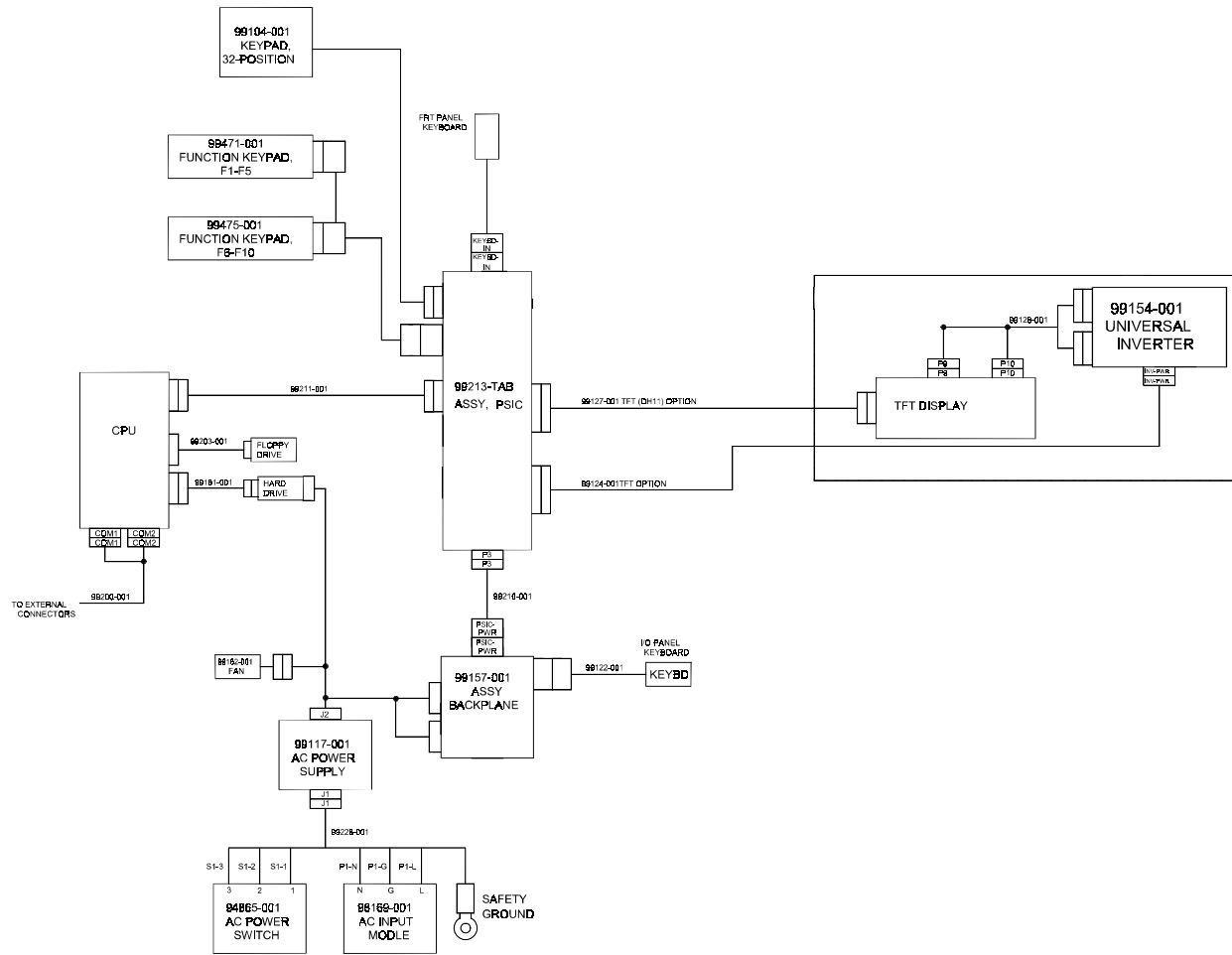

Figure B-1. System Block Diagram

# Appendix C – Pinouts

---

This appendix describes the pinouts for the keyboard, speaker jack, COM1, COM2, and VGA connectors.

## Keyboard Connectors

Two standard five-pin keyboard connectors are available on the 9987. Figure C-1 illustrates the pin locations.

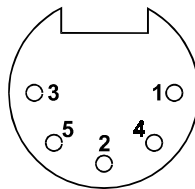

Front View

Figure C-1. Keyboard Connector Pin Locations

Refer to figures 3-1 and 3-3 for the location of these connectors.

Pin	Signal
1	Clock
2	Data
3	NC
4	GND (SG)
5	+5 VDC
6	GND (FG)



## COM1/COM2 Serial Port Connectors

The COM1 and COM2 serial ports are standard DB-9 connectors located on the I/O side of the unit (see Figure 1-4).

Pin	Signal	Pin	Signal
1	DCD1	2	RXD1
3	TXD1	4	DTR1
5	GND	6	DSR1
7	RTS1	8	CTS1
9	RI1		

## VGA Connector (VGA)

The VGA connector is a 15-pin subminiature located on the CPU board. Refer to the CPU manual for more information.

Pin	Signal	Pin	Signal
1	RED	9	KEY
2	GREEN	10	GND
3	BLUE	11	NC
4	NC	12	NC
5	GND	13	HYSNC
6	GND	14	VYSNC
7	GND	15	NC

## Parallel Port Connector (LPT1)

The parallel port connector, LPT1, is a 25-pin female D subminiature connector located on the CPU board. Refer to the CPU manual for more information.

Pin	Signal	Pin	Signal
1	STROBE	14	AUTOFEED
2	PD0	15	PERROR
3	PD1	16	INIT
4	PD2	17	SELIN
5	PD3	18	GND
6	PD4	19	GND
7	PD5	20	GND
8	PD6	21	GND
9	PD7	22	GND
10	PACK	23	GND
11	PBUSY	24	GND
12	PE	25	GND
13	SELECT		

## Speaker Jack Connector

The speaker jack is a subminiature phone jack located on the CPU board. Refer to the CPU manual for more information.

Pin	Signal
TIP	SOURCES CURRENT
SLEEVE	GND

# Index

---

## Numeric

9000-RAD card, installation, 3-7

## A

ACCESS fasteners, 3-3

access, floppy disk, 3-3

approvals, safety agency, 3-19

## B

BIOS

Phoenix, 2-1

Quadtel, 2-2

setup information, 2-3

block diagram, B-1

## C

cable connections

hazardous locations installations, 3-23

communication, 3-24

power, 3-23

Class I locations, 3-21

Class II locations, 3-21

COM1 port, C-2

COM2 port, C-2

communication cable interface, 3-24

connectors

COM1, 3-5, C-2

COM2, 3-5, C-2

keyboard, 3-2, 3-4, C-1

parallel port (LPT1), C-3

printer, 3-5

speaker, 3-5

speaker jack, C-3

VGA, C-2

video, 3-5

CPU, installation into a chassis, 3-17

current, available, 3-18

## D

data entry keypad, 3-2

diagnostics, 2-1

dimensions

logo, 3-15

system cutout, 3-15

display, 3-2

Division 1 locations, 3-21

Division 2 locations, 3-21

DRAM, installation, 3-8

drivers, video, 3-11

## E

EEPROM, 4-8

enclosures, hazardous locations installations, 3-22

environmental specifications, A-2

excessive heat, 3-14

excessive line voltage, 3-14

excessive noise, 3-14

extender cable, installation, 3-9

## F

fan filter, 3-4

maintenance, 5-1

replacement, 5-3

features

optional, 1-2

standard, 1-1

FloNet interface board, 3-8

floppy disk access, 3-3

floppy disk drive, 3-2

function keys, 3-2

fuse replacement, 5-2

## H

hardware specifications, A-1

hardware options

external, 3-9

internal, 3-7

hazardous locations installations, 3-18

definitions

Class I locations, 3-21

Class II locations, 3-21

Division 1 locations, 3-21

Division 2 locations, 3-21

groups, 3-22

enclosures, 3-22

operation and maintenance, 3-24

power switch, 3-23

hazardous locations installations, cable connections, 3-23

heat, excessive, 3-14

hex scan codes, programmable keyboard interface module, 4-9

## I

I/O panel, 3-5

IDE hard drive setup information, 3-3

installation

8x14 font TSR, 3-10

9000-RAD card, 3-7

CPU into a chassis, 3-17

DRAM, 3-8

extender cable, 3-9

external hardware options, 3-9

hazardous locations, 3-18

internal hardware options, 3-7

keyboards, 3-9

MS-DOS, 3-10

panel, 3-12

PC/AT boards, 3-16

serial mouse, 3-10

SIMMs, 3-8

video drivers, 3-11

internal hardware options, installation, 3-7

## K

keyboard

installation, 3-9

port, 3-2

programmable, 4-1

keyboard connectors, C-1

keyboard port, 3-4

keypads

data entry, 3-2

See programmable keyboard interface module, 4-1

## L

LEDs, system status, 3-2

line voltage, excessive, 3-14

locations, hazardous

Class I, 3-21

Class II, 3-21

Division 1, 3-21

Division 2, 3-21

logo dimensions, 3-15

## M

maintenance, 5-1

preventive, 5-1

routine, 5-1

mounting, 3-12, 3-15

mouse, serial, 3-10

MS-DOS, installation, 3-10

## N

noise, excessive, 3-14

## O

On/off switch, 3-4

operation and maintenance, hazardous locations installations, 3-24

options

external hardware, 3-9

internal hardware, 3-7

## P

panel installation, 3-12

parallel port (LPT1) connector, C-3

PC/AT boards, installation, 3-16

PCIM, 3-8

pinouts

COM1, C-2

COM2, C-2

keyboard

connectors, C-1

parallel port, C-3

speaker jack connector, C-3

VGA connector, C-2

PKIM scan codes, programmable keyboard interface module, 4-8

ports

COM1, C-2

COM1/COM2, 3-5

- COM2, C-2
- keyboard, 3-2, 3-4, C-1
- parallel (LPT1), C-3
- printer, 3-5
- speaker, 3-5
- VGA, C-2
- video, 3-5
- power cable connection, 3-23
- power panel, 3-4
- power receptacle, 3-4
- power switch, hazardous locations installations, 3-23
- printer port, 3-5
- product ID label, 3-3
- programmable keyboard interface module, 4-1
  - batch mode, 4-2
  - Download Menu, 4-7
  - Files Menu, 4-3
  - hex scan codes, 4-9
  - loading, 4-1
  - Macros Menu, 4-4
  - Main Menu, 4-3
  - PKIM scan codes, 4-8
  - startup, 4-2
  - Upload Menu, 4-7
  - using, 4-1
  - Utilities Menu, 4-7
- speaker port, 3-5
- specifications
  - environmental, A-2
  - hardware, A-1

## R

- reconnecting slide-out computer module, 3-7
- removing slide-out computer module, 3-6
- repair, 5-4
- replacement
  - fan filter, 5-3
  - fuse, 5-2
  - slide-out computer module, 5-3

## S

- safety agency approvals, 3-19
- serial port connectors, C-2
- serial ports, 3-5
- setup information, IDE hard drive, 3-3
- SIMMs, installation, 3-8
- slide-out computer module
  - reconnecting, 3-7
  - removing, 3-6
  - replacing, 5-3
- spare parts, 5-4
- speaker jack connector, C-3

## system components

## back panel

- ACCESS fasteners, 3-3
- floppy disk access, 3-3
- product ID label, 3-3

## back panel, 3-3

## front panel, 3-1

- data entry keypad, 3-2
- display, 3-2
- floppy disk drive, 3-2
- function keys, 3-2
- keyboard, 3-2

## I/O

- COM1, 3-5
- COM2, 3-5
- printer port, 3-5
- speaker port, 3-5
- video port, 3-5

## I/O panel, 3-5

## power panel, 3-4

- fan/filter, 3-4
- keyboard port, 3-4

## on/off switch, 3-4

## power receptacle, 3-4

## system cutout dimensions, 3-15

## system power, 3-13

## system preparation, 3-5

## system setup, checking, 2-1

## system status LEDs, 3-2

**T**

## testing, 2-1

## TSR, 8x14 font, 3-10

**U**

## unpacking the system, 1-2

**V**

## VGA connector, C-2

## video drivers, installation, 3-11

## video port, 3-5