

PRO-FACE OPERATOR INTERFACES

PRODUCT DATA SHEET



AGP3300-L1-D24



AGP3300L Advanced HMI

5.7" Multi-Port Operator Interface Touch Screen with Simultaneous Driver Support

- Crisp, Clear, Bright 320x240 Resolution Monochrome Display
- 64-bit RISC 133Mhz CPU for Ultra-Fast Screen Refresh and Data Sampling
- No Grid Analog Touch Panel for Improved Visibility and Precise Part Placement
- Supports Up to Two Protocol Drivers Simultaneously
- High Speed Application Transfer, 10 Times Faster than Conventional Operator Interfaces
- 10/100 Base-T Ethernet, USB, Serial (MPI) and CompactFlash™ Communication Interfaces
- High-Definition Part Images and Multi-Language Support

PRODUCT OVERVIEW

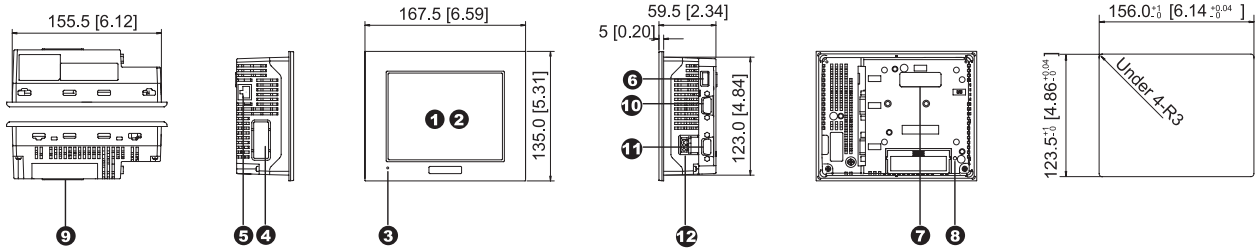

AGP-3300T(AC type) unit shown.

- | | | |
|--|---|--|
| <ul style="list-style-type: none"> ① Display ② Touch Panel ③ Status LED ④ Expansion Communication Feature Interface 1 ⑤ 10/100 Base-T Ethernet Interface (LAN) (RJ45) | <ul style="list-style-type: none"> ⑥ USB 1.1 Type A Interface (Host)
One Port for download, bar-code, printer or other USB device ⑦ Optional Communication Module Interface 2 ⑧ CF Card Access LED ⑨ CompactFlash™ Card Access Cover
(CF cards up to 512MB available) | <ul style="list-style-type: none"> ⑩ Serial Interface (COM1)
RS-232C/RS-422 serial interface. D-sub 9-pin plug type connector. Communication method is switched via software. ⑪ Serial Interface (COM2)
RS-422/RS-485 MPI (187kbps) serial interface. D-sub 9-pin socket type connector. ⑫ Power Plug Connector |
|--|---|--|

COMMUNICATION CAPABILITY

Simultaneous Dual-Protocol Support

Two different protocols can be active at one time.

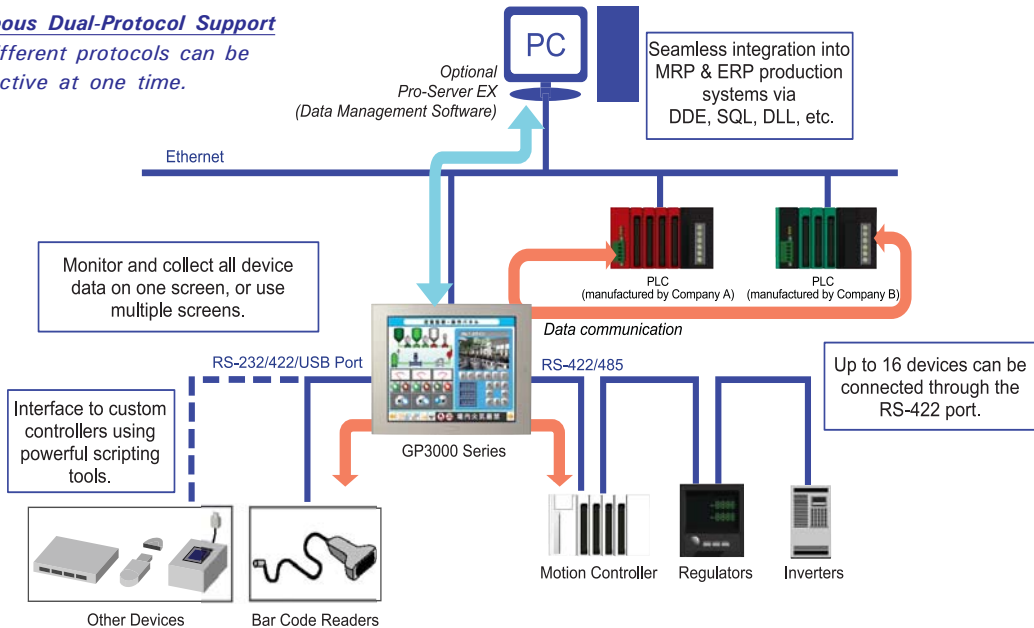

AGP3300L SPECIFICATIONS

FUNCTIONAL SPECIFICATIONS

Model	AGP3300-L1-D24	
Display	Type	Monochrome LCD
	Colors	Black and White (16 shades)
	Backlight	CCFL Service life: 58,000 hrs. or more at 25°C (77°F) and 24 hrs. operation
	Resolution	320 x 240 pixels
	Brightness & Contrast Controls	8 levels of adjustment available via touch panel
Memory	Touch Panel	Resistive film analog 1024 x 1024 resolution
	Application	6 MB FEPRM
Interfaces	Data Backup	320KB SRAM
	Serial (COM 1) Interface	RS-232C/422/485 configurable, 9 pin D-sub plug, Data Transmission Speed: 2400 to 115.2 kbps
	Serial (COM 2) Interface	RS-422/485, 9 pin D-sub socket, Data Transmission Speed: 2400 to 115.2 kbps (MPI Direct 187.5 kbps)
	Ethernet Interface	Ethernet IEEE802.3, 10BASE-T/100BASE-TX, modular jack connector (RJ-45)
	USB Interface	1 Port USB1.1 Host I/F, USB TYPE-A connector
	CF Card Interface	1 slot CompactFlash™, TYPE II

GENERAL SPECIFICATIONS

Electrical	Rated Voltage	24V DC
	Rated Voltage Range	19.2V DC to 28.8V DC
	Power Consumption	26W or less
Environmental	Ambient Operating Temp.	0°C (32°F) to 50°C (122°F)
	Storage Temperature	-20°C (-4°F) to 60°C (140°F)
	Storage Humidity	10%RH to 90%RH (non-condensing, wet bulb temperature: 39°C (102°F) or less)
	Altitude Operation	800hPa to 1114hPa (2000 meters or lower)
Structural	Vibration & Shock Resistance	IEC61131-2 compliant. 5Hz to 9Hz single amplitude 3.5mm, 9Hz to 150Hz fixed acceleration 9.8m/s ² , X,Y, Z directions for 10 times (80min.)
	Ratings	Equivalent to IP65f, Nema #250 Type 4x/13 (Equivalent to NEMA 12 with the addition of "Oil or Coolant Spraying and Splashing")
	Certifications	CE, CSA, UL listed CI 1 Div 2
	External Dimensions	W167.4mm[6.59in.] x H135mm [5.31in.] x D59.5mm [2.34in.]
	Weight	1.0kg (2.2lb) or less

CUT-OUT COMPATIBILITY

16 Years of Cut-Out Compatibility

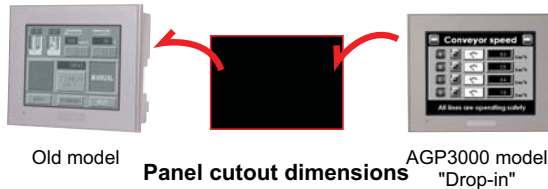

Old model

Panel cutout dimensions

AGP3000 model
"Drop-in"



Size (mm)	156x123.5 mm	
Series		
GP77R Series	GP377R Series	
GP2000 Series	GP2300/ GP2301 Series	
GP3000 Series	GP-3300 Series	

SOFTWARE COMPATIBILITY



POWERED BY:

Screen Editor
GP-Pro EX

HMI Development
Software

ORDERING INFORMATION

ORDER NUMBER	DESCRIPTION
AGP3300-L1-D24	5.7" Monochrome QVGA, USB, Ethernet, Serial HMI, 24VDC

OPTIONAL ACCESSORIES

HMI-CAB-ETH	Ethernet Crossover Cable: HMI to PLC Ethernet port or to program HMI
CA3-USBCB-01	USB download cable, PC USB port to AGP USB port
CA3-DFS6-01	Overlay Screen protection sheet (5 sheets/pack)

PLC Cables & Accessories See AGP3000 Connectivity Document

Ycom Automation
Ph: 734-429-4971
Fax: 734-429-1010
<http://www.ycom.com>

Customer Support Hotline:
734-944-0482



© 2006 Ycom Automation, LLC. Specifications may change without notice.
Ycom Automation is a trademark of Ycom Automation. Other brand or product names are the property of their respective owners.



California Proposition 65 Warning—Lead and Lead Compounds

Advertencia de la Proposición 65 de California—Plomo y compuestos de plomo

Avertissement concernant la Proposition 65 de Californie—Plomb et composés de plomb

⚠ WARNING: This product can expose you to chemicals including lead and lead compounds, which are known to the State of California to cause cancer and birth defects or other reproductive harm. For more information go to: www.P65Warnings.ca.gov.

⚠ ADVERTENCIA: Este producto puede exponerle a químicos incluyendo plomo y compuestos de plomo, que es (son) conocido(s) por el Estado de California como causante(s) de cáncer y defectos de nacimiento u otros daños reproductivos. Para mayor información, visite : www.P65Warnings.ca.gov.

⚠ AVERTISSEMENT: Ce produit peut vous exposer à des agents chimiques, y compris plomb et composés de plomb, identifiés par l'État de Californie comme pouvant causer le cancer et des malformations congénitales ou autres troubles de l'appareil reproducteur. Pour de plus amples informations, prière de consulter: www.P65Warnings.ca.gov.

All trademarks are the property of Schneider Electric SE, its subsidiaries, and affiliated companies.

Schneider Electric USA, Inc.
800 Federal Street
Andover, MA 01810 USA
888-778-2733
www.schneider-electric.us

Todas las marcas comerciales son propiedad de Schneider Electric SE, sus filiales y compañías afiliadas.

Importado en México por:
Schneider Electric México, S.A. de C.V.
Av. Ejercito Nacional No. 904
Col. Palmas, Polanco 11560 México, D.F.
55-5804-5000
www.schneider-electric.com.mx

Toutes les marques commerciales sont la propriété de Schneider Electric SE, ses filiales et compagnies affiliées.

Schneider Electric Canada, Inc.
5985 McLaughlin Road
Mississauga, ON L5R 1B8 Canada
800-565-6699
www.schneider-electric.ca