

12.1" Multi-Media with High Brightness Display - AGP3650U



**TouchPanel
Operation**

12.1-inch TFT Color LCD Operator Interface

AGP-3650U

Models: AGP3650-U1-D24

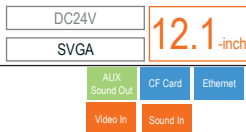

Powered by
SCREEN EDITOR
GP-Pro EX



Features:

- 65,536 Color, Clear, Bright, High-Resolution TFT Display
 - High Brightness Display
 - 64-bit RISC 266Mhz CPU for Ultra Fast Screen Refresh and Data Sampling
 - No Grid Analog Touch Panel for Improved Visibility and Precise Part Placement
 - Supports Up to Four Protocol Drivers
- Simultaneously
- High Speed Application Transfer, 10 Times Faster than Conventional Operator Interfaces
 - 100 Base-T Ethernet, USB, Serial (MPI) and CompactFlash™ Communication Interfaces
 - Includes Alarm, Buzzer Output, Remote Reset Input
 - Direct Video and Audio Input Ports, plus Audio Output

Performance Specifications

| | |
|-----------------------------|--|
| Model | AGP3650-U1-D24 |
| Display Type | High Brightness TFT Color Display |
| Display Colors | 65536 Colors (no Blink/16384 Colors (3-speed Blink) |
| Graphics Display Resolution | (800 x 600 resolution) |
| Backlight | User replaceable CCFL (Service life: 50,000 hrs. or more at 25°C (77°F) and 24 hrs. operation) |
| Touch Screen | Resistive Film (analog) |
| USB | 2 ports USB1.1, Host I/F, USB TYPE-A connector |
| Serial Interface | COM1 RS-232C/422/485, COM2: RS422/485 |
| Ethernet Interface | Ethernet IEEE802.3, 10BASE-T/100BASE-TX, modular jack connector (RJ-45) |
| CF Card | 1 slot CompactFlash™, TYPE II |
| Sound Output | Speaker output 70mW (Rated Load: 8ohm, Frequency: 1kHz) |
| Video Mix Interface | Support for optional GP2000-VM41 4-Channel Video camera input and RGB remote monitor with output. |
| Video Input Interface | NTSC: 59.9Hz PAL: 50Hz Connector: RCA: 75Ω |
| Sound Input Interface | MIC Input/LINE Input (Change with S/W) Connector: MINI-JACK φ3.5mm |
| AUX Input/Output | AUX Discrete Output: Alarm Output, RUN Output, Buzzer Output, Rated: DC24V @ 50mA AUX Discrete Input: Remote Reset Input, Rated: DC24V @ 6mA Operating Voltage: ON State: DC9V or greater, OFF State: DC2.5V or less |

General Specifications

| | |
|---|--|
| Model | AGP3650-U1-D24 |
| Input Voltage | DC24V |
| Power Consumption | 26W or less |
| Allowable Voltage Drop | 10 ms or less |
| Voltage Endurance | AC1000V 20mA for 1 minute (between charging and FG terminals) |
| Insulation Resistance | DC500V 10MΩ(min.) (between charging and FG terminals) |
| Certifications | UL508, CSA-C22.2 No.14 and 142, CE EN55011 Class A, EN61000-6-2, RoHS |
| Ambient Operating Temperature ^{*1} | 0°C (32°F) to 50°C (122°F) |
| Humidity - Ambient/Storage | 10 to 90% RH (Not condensing, wet bulb temperature: 39°C or less). |
| Corrosive Gas | Free of corrosive gases |
| Noise Immunity | Noise Voltage: 1000Vp-p, Pulse Duration: 1μs, Rise Time: 1ns (via noise simulator) |
| Grounding | Grounding resistance of 100Ω 2mm ² or thicker wire, or your country's applicable standard. (same for FG and SG terminals) |
| Electrostatic Discharge Immunity | 6kV (complies with EN 61000-4-2 Level 3) |
| Vibration Resistance | IEC61131-2 compliant. 5Hz to 9Hz single amplitude 3.5mm, 9Hz to 150Hz fixed acceleration 9.8m/s ² , X, Y, Z directions for 10 times (100min.) |
| Rating | Equivalent to IP65f, Nema #250 Type 4x/13 (Equivalent to NEMA 12 with the addition of "Oil or Coolant Spraying and Splashing") |
| Weight | 3.0kg (6.6lb) or less |
| External Dimensions | W313mm[12.31in.] x H239mm [9.41in.] x D56mm [2.20in.] |
| Warranty | Two (2) year |

*1 Ambient Operating Temperature indicates the cabinet interior or panel face temperature..

AGP-3650U - External Dimensions

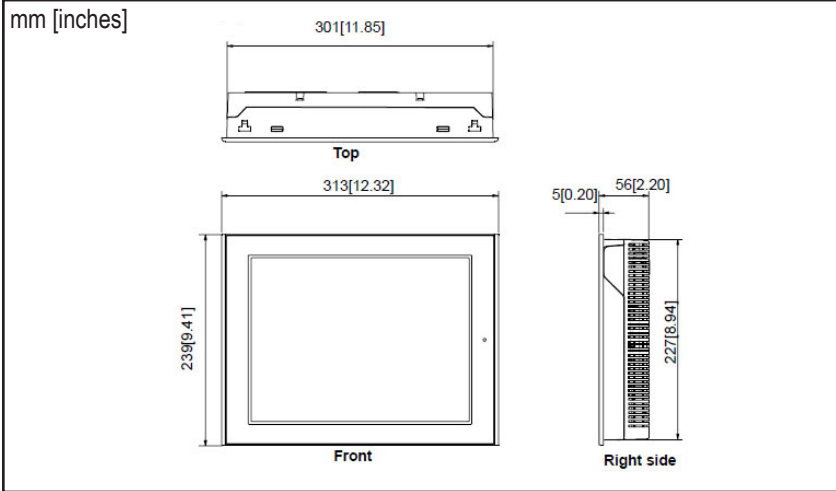

Ordering Information

| Part Number | Description |
|----------------|---|
| AGP3650-U1-D24 | 12.1" TFT, 2 Serial, 2 USB, Sound, Video, Ethernet, DC24V |

Accessories or Replacement Components

| Product Name | Part Number |
|--|----------------------------|
| Ethernet Crossover Cable | HMI-CAB-ETH |
| USB Transfer Cable | CA3-USBCB-01 (2m) |
| Installation Fasteners | CA3-ATFALL-01 |
| GP-Pro EX HMI Development Software | EX-ED-Vxx (latest version) |
| Screen Protection Sheet (5 sheets/set) | CA3-DFS6-01 |

- All information contained in this document is subject to change without notice.

AGP-3650T - Cut-Out Dimensions

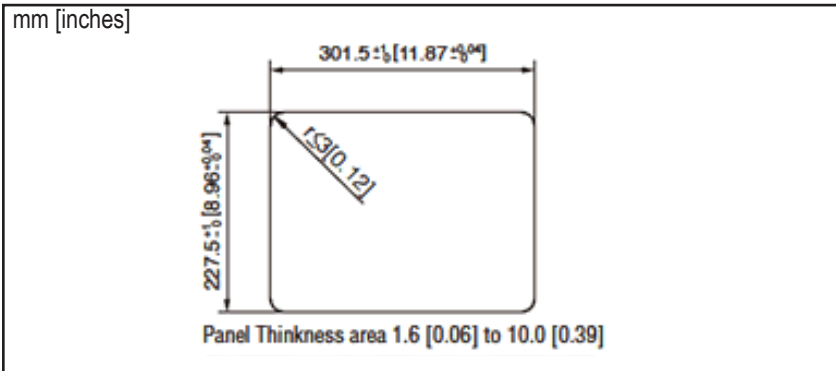

High Brightness Features

Improved visibility in brightly lit locations. Focused reflection of light improves visibility for the operator

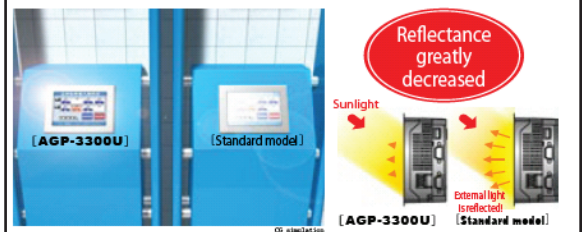

Simultaneous Multi-Protocol Support
Up to four different protocols can be active at one time.

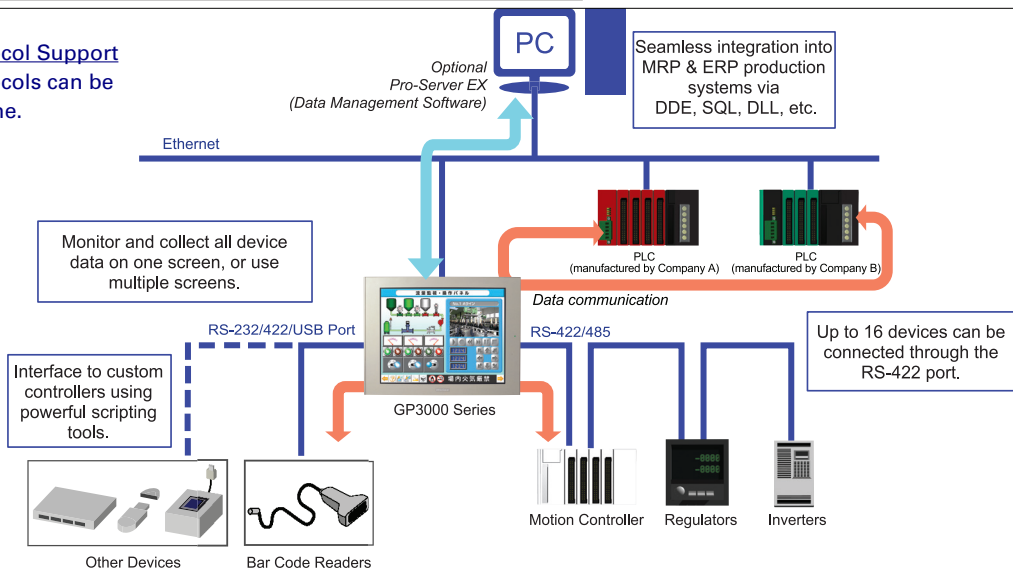

Pro-face America
Phone: 734.429.4971
Fax: 734.429.1010
www.profaceamerica.com

Customer Service Hotline: 734.944.0482

For more information
ACCESS www.profaceamerica.com

Pro-face
Human Machine Interface



California Proposition 65 Warning—Lead and Lead Compounds

Advertencia de la Proposición 65 de California—Plomo y compuestos de plomo

Avertissement concernant la Proposition 65 de Californie—Plomb et composés de plomb

⚠ WARNING: This product can expose you to chemicals including lead and lead compounds, which are known to the State of California to cause cancer and birth defects or other reproductive harm. For more information go to: www.P65Warnings.ca.gov.

⚠ ADVERTENCIA: Este producto puede exponerle a químicos incluyendo plomo y compuestos de plomo, que es (son) conocido(s) por el Estado de California como causante(s) de cáncer y defectos de nacimiento u otros daños reproductivos. Para mayor información, visite : www.P65Warnings.ca.gov.

⚠ AVERTISSEMENT: Ce produit peut vous exposer à des agents chimiques, y compris plomb et composés de plomb, identifiés par l'État de Californie comme pouvant causer le cancer et des malformations congénitales ou autres troubles de l'appareil reproducteur. Pour de plus amples informations, prière de consulter: www.P65Warnings.ca.gov.

All trademarks are the property of Schneider Electric SE, its subsidiaries, and affiliated companies.

Schneider Electric USA, Inc.
800 Federal Street
Andover, MA 01810 USA
888-778-2733
www.schneider-electric.us

Todas las marcas comerciales son propiedad de Schneider Electric SE, sus filiales y compañías afiliadas.

Importado en México por:
Schneider Electric México, S.A. de C.V.
Av. Ejercito Nacional No. 904
Col. Palmas, Polanco 11560 México, D.F.
55-5804-5000
www.schneider-electric.com.mx

Toutes les marques commerciales sont la propriété de Schneider Electric SE, ses filiales et compagnies affiliées.

Schneider Electric Canada, Inc.
5985 McLaughlin Road
Mississauga, ON L5R 1B8 Canada
800-565-6699
www.schneider-electric.ca