

Preface

Thank you for purchasing Digital Corporation's Pro-face Graphic Logic Controller GLC2400 (referred as "GLC" from here on).

This controller features a number of improvements over the previous GLC series including enhanced functions and advanced operability. Flex Network communication, Ethernet, CF Card and Sound output are available for the GLC2400 without having to purchase and mount an extension unit.

Please read this manual carefully as it explains, step by step, how to use the GLC correctly and safely.

Also, in this manual's examples, the Mitsubishi MELSEC-AnA Series PLC is used whenever possible, connected in a one-to-one relationship with a GLC.

<Note>

- 1) It is forbidden to copy the contents of this manual, in whole or in part, except for the user's personal use, without the express permission of Digital Electronics Corporation of Japan.
- 2) The information provided in this manual is subject to change without notice.
- 3) This manual has been written with care and attention to detail; however, should you find any errors or omissions, please contact Digital and inform them of your findings.
- 4) Please be aware that Digital shall not be held liable by the user for any damages, losses, or third party claims arising from any uses of this product.

All Company/Manufacturer names used in this manual are the registered trademarks of those companies.

© Copyright 2000, Digital Electronics Corporation

Table of Contents

Preface	1
Table of Contents	2
Essential Safety Precautions	6
General Safety Precautions	10
About GLC2400 Series Models	12
Package Contents	12
UL/c-UL Approval Notes	13
CE Marking Notes	13
Documentation Conventions	14

CHAPTER 1 INTRODUCTION

1.1 Prior to Operating the GLC	1-1
1.2 System Design	1-2
1.3 Accessories	1-5
1.4 GLC2400 Series Overview	1-8
1.4.1 Connecting to an Ethernet Network	1-9
1.4.2 CF Card	1-10
1.4.3 Sound Output	1-11
1.4.4 Expansion Serial I/F	1-11
1.4.5 Flex Network I/F	1-12
1.4.6 Printer/Serial Device/ Tool Connector Interface	1-12
1.4.7 Internal 2-Port Feature	1-13
1.4.8 Backlight Burnout Detection Feature	1-14

CHAPTER 2 SPECIFICATIONS

2.1 General Specifications	2-1
2.1.1 Electrical	2-1
2.1.2 Environmental	2-2
2.1.3 Structural	2-2
2.2 Functional Specifications	2-3
2.2.1 Display	2-3
2.2.2 Memory	2-4
2.2.3 Control Memory	2-4
2.2.4 Clock	2-4
2.2.5 Interfaces	2-5
2.3 Interface Specifications	2-6
2.3.1 Serial Interfaces	2-6

2.3.2 Printer Interface	2-9
2.3.3 Auxiliary I/O, Flex Network and Sound Output	2-9
2.4 Part Names and Functions	2-9
2.5 Dimensions	2-11
2.5.1 GLC-2400T External Dimensions	2-11
2.5.2 Installation Fasteners	2-11
2.5.3 Panel Cut Dimensions	2-12

CHAPTER 3 INSTALLATION AND WIRING

3.1 Installation	3-1
3.1.1 Installation Procedures	3-1
3.2 Wiring Cautions	3-6
3.2.1 Connecting the Power Cord	3-6
3.2.2 Connecting the Power Supply	3-8
3.2.3 Grounding	3-9
3.2.4 I/O Signal Line Placement	3-10
3.2.5 Installation Cautions	3-10
3.3 Tool Connector	3-13
3.4 Ethernet Cable Connector	3-13
3.5 CF Card Insertion and Removal	3-14
3.6 Connecting to the Screw Lock Terminal	3-16
3.6.1 Cable Preparation	3-16
3.6.2 Terminal Connection	3-16
3.6.3 Sound Volume Adjustment	3-18

CHAPTER 4 DATA TRANSFER

4.1 Serial Data Transfer	4-1
4.2 Ethernet Data Transfer	4-4
4.2.1 Checking the IP Address	4-6
4.3 CF Memory Loader Tool	4-7
4.3.1 Data Upload/Download	4-8

CHAPTER 5 OFFLINE MODE

5.1 Entering OFFLINE Mode	5-1
5.1.1 After Plugging in the Power Cord	5-1
5.1.2 From the Menu Bar	5-2
5.2 OFFLINE Mode Main Menu	5-3
5.3 INITIALIZATION	5-4
5.4 SELF-DIAGNOSIS	5-6

CHAPTER 6 INITIALIZING THE GLC

6.1 Initialization Screen	6-1
6.2 Initialization Items	6-2
6.3 SYSTEM ENVIRONMENT SETUP	6-3
6.3.1 SYSTEM SETUP	6-3
6.3.2 SYSTEM AREA SETUP	6-4
6.3.3 GLOBAL WINDOW SETUP	6-6
6.3.4 CHARACTER STRING DATA SETUP	6-7
6.4 SET UP I/O	6-10
6.4.1 SET UP SIO	6-10
6.4.2 SET UP PRINTER	6-11
6.4.3 SET UP TOUCH PANEL	6-12
6.4.4 COMMUNICATION SETUP	6-14
6.4.5 SOUND SETTINGS	6-14
6.4.6 EXPANSION SERIAL COMMUNICATION SETUP	6-15
6.4.7 EXPANSION SERIAL ENVIRONMENT SETUP	6-16
6.5 PLC SETUP	6-17
6.5.1 SET UP OPERATION SURROUNDINGS(1:1/n:1).....	6-17
6.5.2 STATION SETUP(n:1).....	6-18
6.5.3 CUSTOMIZE SETUP (n:1)	6-20
6.5.4 ETHERNET SETUP	6-22
6.5.5 SYSLOG SETUP	6-23
6.5.6 OTHERS SETUP	6-24
6.5.7 SELF DIAGNOSIS	6-24
6.5.8 Controller Settings	6-25
6.6 INITIALIZE INTERNAL MEMORY	6-27
6.6.1 INITIALIZE GLC MEMORY	6-27
6.6.2 INITIALIZE CF CARD	6-27
6.7 SET UP TIME	6-28
6.8 SET UP SCREEN	6-29

CHAPTER 7 RUN MODE AND ERRORS

7.1 RUN Mode..... 7-1

 7.1.1 After Connecting the Power Cord 7-1

 7.1.2 Via OFFLINE Mode 7-2

7.2 SELF-DIAGNOSIS 7-3

 7.2.1 SELF-DIAGNOSIS ITEM LIST 7-3

 7.2.2 SELF-DIAGNOSIS - Details..... 7-4

7.3 Troubleshooting..... 7-8

 7.3.1 Possible Types of Trouble..... 7-8

 7.3.2 No Display 7-9

 7.3.3 No GLC/Host Communication 7-12

 7.3.4 Touch Panel Does Not Respond 7-14

 7.3.5 Cannot Execute Logic Program..... 7-15

 7.3.6 Buzzer Sounds When GLC Power is Turned ON 7-16

7.4 Error Messages..... 7-17

 7.4.1 Error Message List 7-17

 7.4.2 Error Message Details 7-19

CHAPTER 8 MAINTENANCE

8.1 Regular Cleaning 8-1

 8.1.1 Cleaning the Display 8-1

 8.1.2 Installation Gasket Check/Replacement 8-1

8.2 Periodic Check Points 8-3

8.3 Replacing the Backlight 8-4

INDEX

Essential Safety Precautions

This guide contains a variety of safety markings for safe and correct operation of this Unit. Please read this installation guide and any related manuals carefully to fully understand how to correctly use this Unit's functions.

■ Safety Symbols

Please pay attention to these symbols and follow all instructions given.

The safety symbols and their meanings are as follows:



Indicates situations where severe bodily injury, death or major machine damage will definitely occur.



Indicates situations where severe bodily injury, death or major machine damage can possibly occur.



Indicates situations where slight bodily injury or machine damage can occur.

DANGERS

When Designing your GLC System:

- **Be sure to design your GLC control system so that in the event of a main power supply failure or a GLC accident, the user system's overall safety integrity will be maintained. If this is not done, incorrect output signals or a GLC malfunction may cause an accident.**
- (1) Interlock circuits, etc. designed to interrupt or oppose normal machine movement (i.e. Emergency Stop, General Protection, forward and reverse rotation, etc.), as well as those designed to prevent machine damage (i.e. for upper, lower and traverse movement limit positioning, etc.) should all be designed to be located outside of the GLC.**

 **DANGERS**

- (2) Whenever the GLC generates a “Watchdog Timer Error”, GLC operation will halt. Also, when Errors occur in Input/Output control areas that the GLC cannot detect, it is possible for unexpected movement to occur in those areas. As a result, for the purpose of preventing unsafe machine movement, a “Failsafe Circuit” should be created which is completely external to the GLC.
- (3) If an problem arises with an external unit’s relay or transistor, causing an output (coil) to remain either ON or OFF, a major accident can occur. To prevent this, be sure to set up external watchdog circuits that will monitor vital output signals.
- Design a circuit that will supply power to the GLC’s I/O unit before starting up the GLC. If the GLC’s internal program enters RUN mode prior to the I/O unit’s load control power turning ON, an incorrect output (signal) or malfunction could cause an accident to occur.
 - Design a user program that will ensure the safety of the user’s system, in the event of a GLC display or control error, or in the event of either a data transmission error or power failure between the GLC and a connected unit. These types of problems can lead to an incorrect output (signal) or malfunction, which could thereby cause an accident to occur.
 - Do not use the GLC unit as a warning device for critical alarms that can cause serious operator injury, machine damage or production stoppage. Critical alarm indicators and their control/activator units must be designed using stand-alone hardware and/or mechanical interlocks.
 - Do NOT use GLC touch panel switches to perform life-related or important accident prevention operations. These operations should be performed by separate hardware switches to prevent operator injury and machine damage.

DANGERS

- Please design your system so that equipment will not malfunction due to a communication fault between the GLC and its host controller. This is to prevent any possibility of bodily injury or material damage.
- The GLC is not appropriate for use with aircraft control devices' or medical life support equipment, central trunk data transmission (communication) devices, nuclear power control devices, or medical life support equipment, due to these devices' inherent requirements of extremely high levels of safety and reliability.
- When using the GLC with transportation vehicles (trains, cars and ships), disaster and crime prevention devices, various types of safety equipment, non-life support related medical devices, etc. redundant and/or failsafe system designs should be used to ensure the proper degree of reliability and safety.

WARNINGS

- After the GLC's backlight burns out, unlike the GLC's "Standby Mode", the touch panel is still active. If the operator fails to notice that the backlight is burned out and touches the panel, a potentially dangerous machine missoperation can occur.
 - 1) If your GLC is not set to " Standby Mode" and the screen has gone blank, your backlight is burned out.
 - 2) Or, if your GLC is set to Standby Mode, but touching the screen does not cause the display to reappear, your backlight is burned out.
- Also, to prevent accidental machine miss-operation, Digital suggests you use the GLC's built-in "USE TOUCH PANEL AFTER BACKLIGHT BURNOUT" feature, that will automatically detect a burnout and disable the touch screen.



WARNINGS

Installation Warnings:

- High voltage runs through the GLC. Except for replacing the backlight, never disassemble the GLC, otherwise an electric shock can occur.
- Do not modify the GLC unit. Doing so may cause a fire or an electric shock.
- Do not use the GLC in an environment where flammable gasses are present, since operating the GLC may cause an explosion.

Wiring Warnings:

- To prevent electric shock or equipment damage, prior to installing or wiring the GLC, confirm that the GLC's power cord is unplugged from the power supply.
- After completing any GLC wiring work, be sure the terminal block's protective plastic cover is reattached. If this cover is not reattached, an electric shock could easily occur.
- High voltage runs through the GLC. Except for changing the backlight, do NOT attempt to open the GLC, since there is a possibility of an electric shock.
- Do not use power levels with the GLC that are outside of the GLC's specified power range. Doing so may cause a fire, electric shock or damage the GLC.
- Do not operate or store the GLC in areas where flammable gasses are present, since operating the GLC may cause an explosion.

Operation and Maintenance Warnings:

- Never touch a live power terminal. This could cause a shock or machine malfunction.
- Due to the danger of an electric shock, confirm that the GLC's power cord is unplugged before either cleaning the GLC or attaching/detaching the power terminal screws.
- When replacing the GLC's backlight, be sure to unplug the unit's power cord to prevent a shock, and wear gloves to prevent being burned.

WARNINGS

- The GLC uses a lithium battery for backing up its internal clock and control memory data. If the battery is incorrectly replaced (i.e. the + and - sides are reversed), the battery may explode. Therefore, before changing the battery, Digital recommends that you contact your local GLC distributor for battery replacement instructions.
- Do not attempt to modify the GLC's internal parts or wiring in any way, since this may lead to either a shock or fire.

CAUTIONS

Wiring Layout Cautions:

- Be sure that all GLC input/output signal lines are isolated from all power wiring or power cables, via a separate wiring duct. This is to prevent excessive noise, which can cause a unit malfunction.

Installation Cautions:

- Be sure any data cable attached to the GLC's connector is securely attached. If the cable and connector pins do not all make complete contact, incorrect input or output signals can result.

General Wiring Cautions

- To prevent shocks or malfunctions, GLC's FG (earth) wire should be grounded according to the following:
 - 1) A maximum grounding resistance of 100 W or less.
 - 2) A grounding wire of 2mm² or larger should be used.
- The GLC's wiring should be checked to confirm both that the operating voltage and wiring terminal locations are correct. If either the voltage or the wiring terminal locations are incorrect, it can cause a fire or accident.
- Be sure to secure all wiring terminal screws in place with the designated torque. Screws and terminals that become loose can cause a short circuit, fire or accident.



CAUTIONS

- Be sure that metal filings or wiring remnants do not fall inside the GLC, since they can cause a fire, accident, or malfunction.

GLC Operation and Maintenance Cautions

- Be sure to read the GLC's manual and on-line help information carefully before performing program changes, forced output, or utilizing the RUN, STOP or PAUSE commands while the GLC is in operation. Mistakes concerning the use of these items can cause a machine accident or damage.
- The liquid crystal panel contains a powerful irritant and if for any reason the panel is damaged and this liquid enters your eye, flush your eye for 15 minutes with running water and contact a physician.
- Prior to inserting or removing a CF Card, be sure to turn the GLC's CF Card ACCESS switch OFF and to confirm that the ACCESS lamp is not lit. If you do not, CF Card internal data may be damaged or lost.
- While a CF Card is being accessed, NEVER turn OFF or reset the GLC, or insert or remove the CF Card. Prior to performing these operations, create and use a special GLC application screen that will prevent access to the CF Card.

GLC Unit Disposal Cautions

- The GLC unit should be disposed of in a manner appropriate to the user country's industrial machinery disposal standards.

General Safety Precautions



- *Do not strike the touch panel with a hard or pointed object, or press on the touch panel with too much force, since it may damage the touch panel or the display.*
- *Do not install the GLC where the ambient temperature can exceed the allowed range. Doing so may cause the GLC to malfunction or shorten its operation life.*
- *Do not restrict or limit the GLC's naturally occurring rear-face ventilation, or storing or using the GLC in an environment that is too hot.*
- *Do not use this unit in areas where large, sudden temperature changes can occur. These changes can cause condensation to form inside the unit., possibly causing the unit to malfunction.*
- *Do not allow water, liquids, metal or charged particles to enter inside the GLC's case, since they can cause either a GLC malfunction or an electrical shock.*
- *Do not use or store the GLC in direct sunlight, or in excessively dusty or dirty environments.*
- *Do not store or use the unit where strong jolting or excessive vibration can occur.*
- *Do not store or use the GLC where chemicals (such as organic solvents, etc.) and acids can evaporate, or where chemicals and acids are present in the air.*



Corrosive chemicals: Acids, alkalines, liquids containing salt

Flammable chemicals: Organic Solvents

- *Do not use paint thinner or organic solvents to clean the GLC.*
- *Do not store or operate the LCD display in areas receiving direct sunlight, since the sun's UV rays may cause the LCD display's quality to deteriorate.*
- *Storing this unit in areas at a temperature lower than is recommended in this manual's specifications may cause the LCD display's liquid to congeal, which may damage the panel. Conversely, if the storage area's temperature becomes higher than the allowed level, the LCD's liquid will become isotropic, causing irreversible damage to the LCD. Therefore, be sure to store the panel only in areas where temperatures are within those specified in this manual.*
- *Due to the possibility of unexpected accidents, be sure to back up the GLC's screen data regularly.*

■ About the GLC's Display Panel

- *The GLC's currently displayed data, its voltage*¹ and brightness setting each affect the intensity of Contouring. (i.e, when some parts of the screen are brighter than others, creating a wavelike pattern)*
- *There are minute grid-points (dark and light) on the Display Panel's surface. This is part of the GLC's design and not a defect.*
- *Extended shadows, or "Crosstalk" may appear on the sides of screen images. This is normal for an LCD display.*
- *Sometimes the display area may look as if the display colors have changed. This is a common attribute of LCD's and is not a defect.*
- *Displaying a single image for long periods can cause an afterimage to remain when the display is changed to another screen.*

To prevent this effect:

- *Use the GLC's "Stand-by Mode", which automatically turns the screen OFF when there is no input for a specified period of time.*

▼ **Reference** 5.3.1 System Setup

- *Write "FFFFh" to the System Data Area's "Screen Display Off" address*² to turn the screen display OFF when the following actions are not performed for the user's designated period of time.*
 - *Change Screen*
 - *Touch Screen*
 - *Alarm Display*
- *Do not display any single screen for a long period of time. Try to periodically change the screen display.*

*1 *If the GLC's voltage is at the very low end of its allowable range, it may effect the intensity of contouring.*

*2 *The following addresses assume all System Data Area settings are entered. If they are not all entered, the correct word address may be different from those given here.*

With the Direct Access Method — use System Data Area word address +9

With the Memory Link Method — use System Data Area word address +12

▼ **Reference** GP-PRO/PBIII for Windows PLC Connection Manual

About GLC2400 Series Models

The GLC2400 Series refers to the following GLC model number:

Model Name	Model Type	Comments
GLC2400T	GLC2400-TC41-24V	UL/cUL Approved, CE Marked

Package Contents

The GLC's packing box contains the items listed below. Please check to confirm that all items shown below have been included.

■ **GLC Unit (1)**

GLC2400-TC41-24V

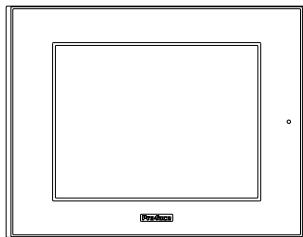

■ **Installation Guide (1)****

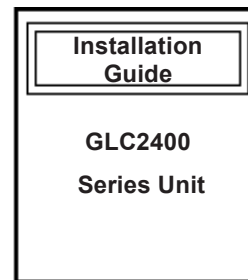

■ **Installation Fasteners (4/set)**

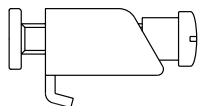

This unit has been carefully packed, with special attention to quality. However, should you find anything damaged or missing, please contact your local GLC distributor immediately for prompt service.

**1 The GLC2400 Series User Manual) is sold separately.*

UL/c-UL (CSA) Application Notes

The GLC2400-TC41-24V is a UL/c-UL (CSA) listed product. (UL file No.E182139)

This unit conforms as a product to the following standards:

- **UL508** Industrial Control Equipment
- **UL1604** Electrical Equipment for use in Class 1 & 2 - Division 2, or Class 3 Hazardous Locations.

■ **CAN/CSA-C22.2, Nos 142, and 213-M1987**

Standard for Safety of Information Technology Equipment, including Electrical Business Equipment

GLC2400-TC41-24V (**UL Registration Model: 2980025**)

<Cautions>

- The GLC must be used as a built-in component of an end-use product.
- This unit should be installed in the front face of a metal panel.
- If this unit is installed so as to cool itself naturally, be sure to install it in a vertical panel. Also, be sure that the GLC unit is mounted at least 100 mm away from any adjacent structures or equipment. If these requirements are not met, the heat generated by the GLC unit's internal components may cause the unit to fail to meet UL/c-UL standard requirements.

UL1604 Conditions of Acceptability and Handling Cautions:

1. Power, input and output (I/O) wiring must be in accordance with Class I, Division 2 wiring methods - Article 501- 4(b) of the National Electrical Code, NFPA 70 within the United States, and in accordance with Section 18-152 of the Canadian Electrical Code for units installed within Canada.
2. Suitable for use in Class I, Division 2, Groups A, B, C and D, Hazardous Locations.
3. WARNING: Explosion hazard - substitution of components may impair suitability for Class I, Division 2.
4. WARNING: Explosion hazard - when in hazardous locations, turn power OFF before replacing or wiring modules.
5. WARNING: Explosion hazard - do not disconnect equipment unless power has been switched OFF, or the area is known to be non-hazardous.



CE Marking Notes

The GLC2400-TC41-24V is a CE marked product that conforms to EMC directives EN55011 class A and EN50082-2.

** For detailed CE marking information, please contact your local GLC distributor.*

Documentation Conventions

The list below describes the documentation conventions used in this manual.

Symbol	Meaning
	Indicates important information or procedures that must be followed for correct and risk-free software/device operation.
Pro-Control Editor	Indicates software used to create, transfer and monitor a GLC logic program.
GLC	GLC2400-TC41-24V
GP Screen Editor	Indicates the GP-PRO/PB III for Windows screen editor software.*1
Logic Program	Ladder program created with the Pro-Control Editor (Ver.3.0. or later).
	Provides useful or important supplemental information.
	Refers to useful or important supplemental information.
PLC	Abbreviation for Programmable Logic Controller.

**1 When using GLC-PRO/PB III for Windows Ver. 4.0 with the GLC2400 Series unit, the additional software "GLC2400 Update Kit CD-ROM" needs to be installed in your PC.*

Chapter

1 Introduction

1. Prior to Operating the GLC
2. System Design
3. Accessories
4. GLC2400 Series Overview

1.1 Prior to Operating the GLC

Be sure to follow these steps when creating projects for the GLC unit.

- 1 Preparation** Before using the GLC, check that all required hardware is present and read all specification, wiring, and installation information.
▼Reference▲ *Chapter 2, "Specifications" and Chapter 3, "Installation and Wiring"*
- 2 Screen Design** Create a sample screen and design a Tag layout, with the Screen layout sheets and Tag lists provided in the Editor software.
- 3 Installing Screen Editor Software**
Install GP-PRO/PB III for Windows to the PC.
▼Reference▲ *GP-PRO/PB III for Windows Operation Manual (Included with screen creation software)*
- 4 Installing Logic Program Development Software**
Install Pro-Control Editor to the PC with GP-PRO/PB III for Windows.
▼Reference▲ *Pro-Control Editor Operation Manual (Included with Pro-Control Editor)*
- 5 Develop Logic Program**
Develop a logic program using Pro-Control Editor and set the operation mode.
▼Reference▲ *Pro-Control Editor Operation Manual (Included with Pro-Control Editor)*
- 6 Importing Symbols, Draw/Setting Operation/Display Data Transfer**
Import Symbols using GP-PRO/PB III for Windows, make the screens and then transfer them to the GLC.
▼Reference▲ *GP-PRO/PB III for Windows Operation Manual (Included with screen creation software)*
- 7 Transfer/Monitor Logic Program**
Transfer program to the GLC using Pro-Control Editor. The transferred program's operation can be checked with the monitor feature of Pro-Control Editor.
▼Reference▲ *Pro-Control Editor Operation Manual (Included with Pro-Control Editor)*
- 8 Initial Set Up** Initial set up of the GLC. Set up the GLC according to usage.
▼Reference▲ *GLC User Manual (sold separately), GP-PRO/PB III for Windows PLC Connection Manual (included with screen creation software)*
- 9 Operation** To start operation, connect the GLC with your peripheral devices, temperature controllers or inverters.
▼Reference▲ *GP-PRO/PB III for Windows PLC Connection Manual (included with screen creation software), User Manual for each extension unit*

1.2 System Design

The following diagram represents the main selection of devices connectable to the GLC.

■ GLC RUN Mode Peripherals

GLC Unit

GLC2400-TC41-24V

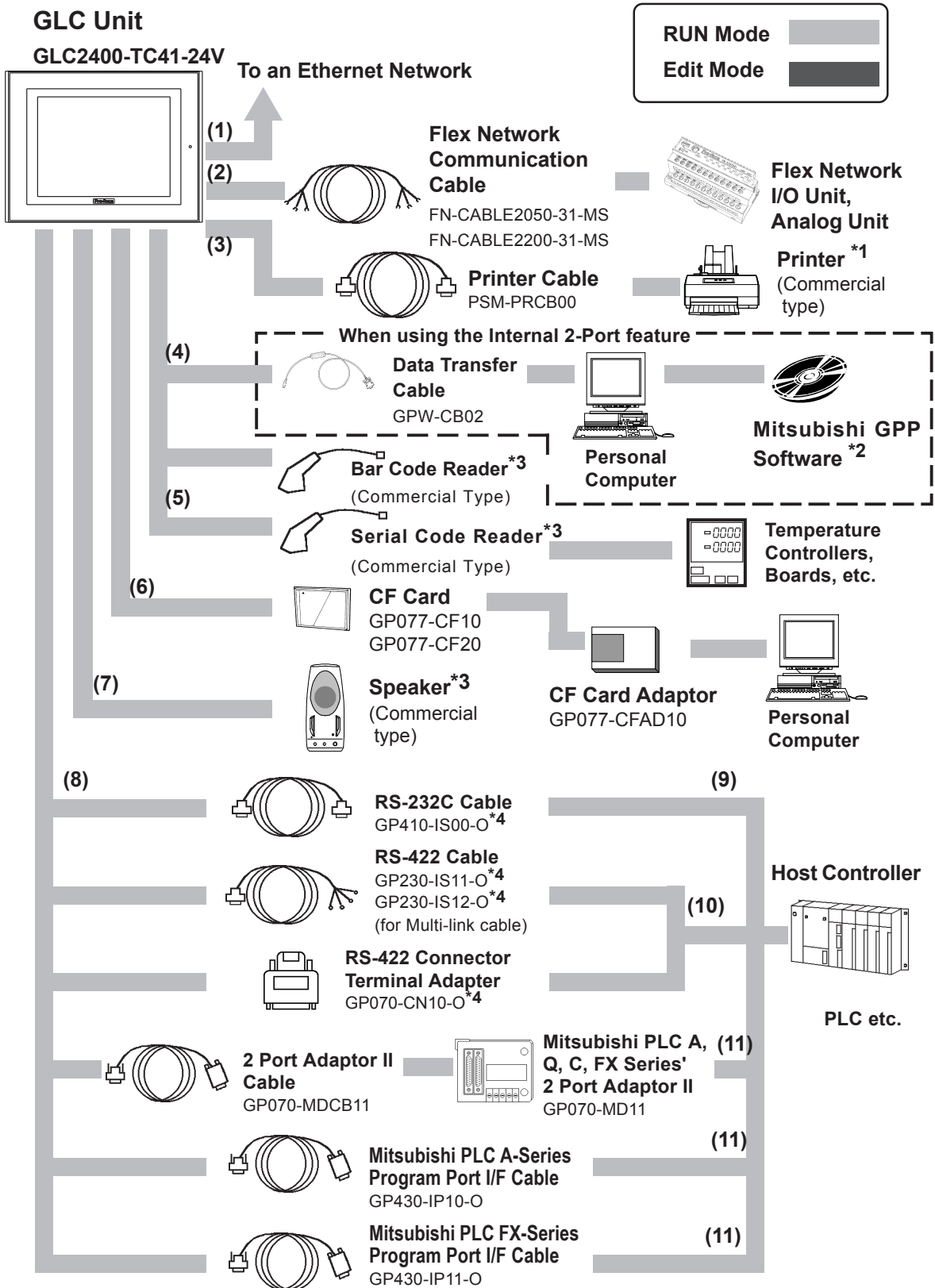

■ GP Edit Mode Peripherals

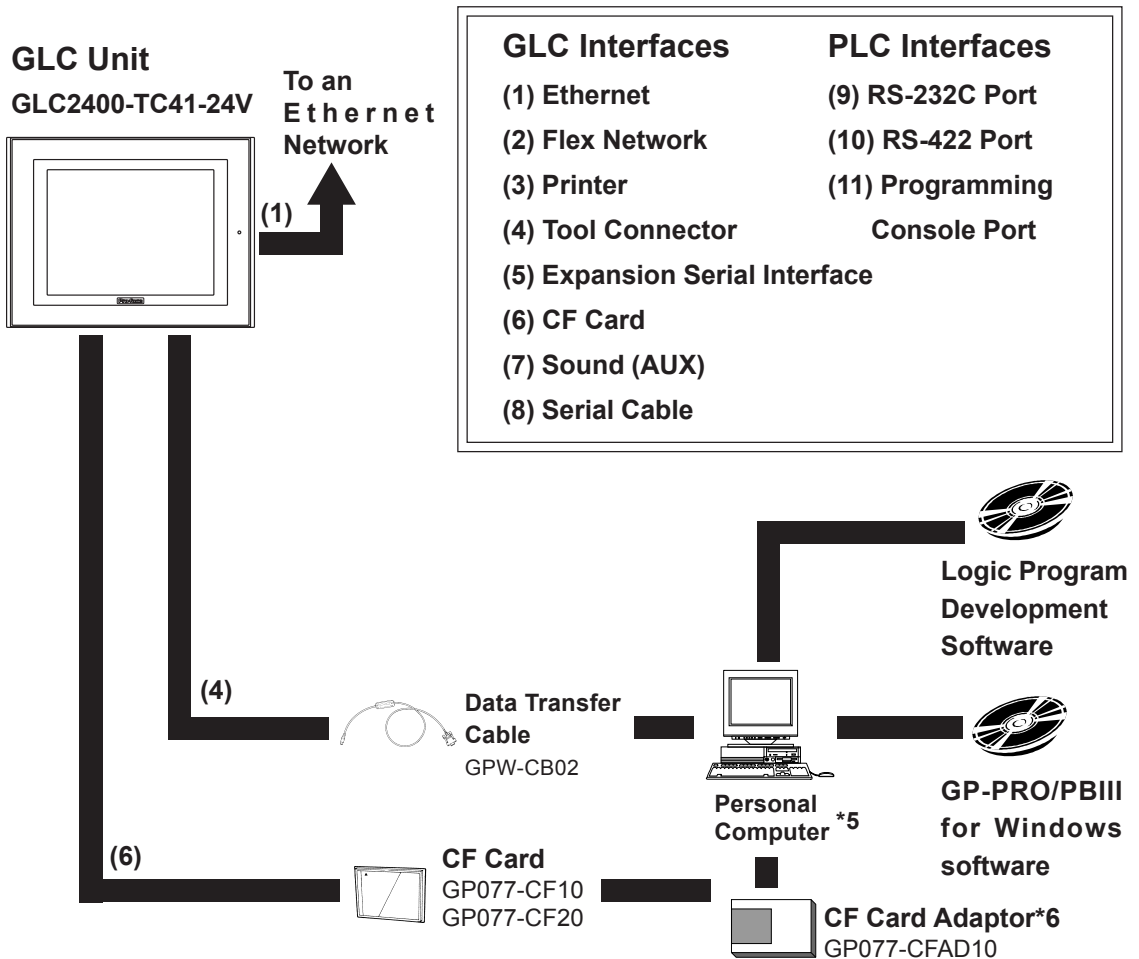

*1 Compatible with NECPC-PR201/PL , EPSON ESC/P24-J84(C), HP Laser Jet PCL 4 command printers or their equivalent that are designed for MS-DOS. Printers designed solely for Windows may not be used. Certain printers containing both Windows and DOS drivers may be used. For details, please contact your printer's manufacturer or sales outlet.

*2 For information about compatible PLC types and software, please refer to

▼ **Reference** ▲ *GP-PRO/PBIII for Windows PLC Connection Manual* (included with the screen creation software)

*3 For information about recommended units, please refer to the next page.

*4 Certain types and models of PLCs cannot be connected.

▼ **Reference** ▲ *GP-PRO/PBIII for Windows PLC Connection Manual* (included with the screen creation software)

*5 For the full range of compatible PCs, refer to the following manual.

▼ **Reference** ▲ *GP-PRO/PBIII for Windows Operation Manual* (included with the screen creation software)

*6 The total amount of the data of the CF Memory Loader Tool and Back-up Data will be over 8M . Use the GP077-CF20 (16MB) when you use the CF Memory Loader Tool.

Chapter 1 - Introduction

■ Recommended Units

The following tables list I/O devices that have been confirmed to be compatible with the GLC. If you connect a device other than those listed below, be sure to confirm that the connection functions correctly using the actual unit.



Recommended units are subject to additions/changes without notice.

◆ Bar code readers (Connected to Tool Connector)

Manufacturer	Model	Type
Aimex Corporation	BR-331 PC2	Pen
OPT Electronics	OPT-1105-RSK 98 Set	Touch Scanner (Read Width: 60mm)
	OPT-5105-RSK 98 Set	Touch Scanner (Read Width: 80mm)
	OPT-6735-RSK 98 Set	Touch Scanner (Read Width: 100mm)
T ohken	TCD-5510M	Touch Scanner (Read Width: 65mm)
	TCD-5510L	Touch Scanner (Read Width: 82mm)
	TCD-5510W	Touch Scanner (Read Width: 105mm)

◆ Bar Code Reader (Connected to Expansion Serial Interface)*1

Manufacturer	Model	Type	Remarks
Aimex Corporation	BR-730RS	Pen	Battery powered
	BR-530RS	Pen	Requires separately sold BB-60 for power.
	BW-665RS	Touch Scanner (Read Width: 65mm)	
OPT Electronics	OPT-5125-RS232C-K	Touch Scanner (Read Width: 60mm)	Requires separately sold DC5300T for power.
	OPT-5125-RS232C-H	Touch Scanner (Read Width: 80mm)	
	NFT-7175-L-RS232C	Fixed Type (Read width: 60mm)	
Olympus Symbol	LS4004	Laser Scanner	Includes power supply.
	LS4004i	Laser Scanner	Includes power supply.
	LS6004	Laser Scanner	Includes power supply.
	LSH3502AHV	Laser Scanner	Includes power supply.
Keyence Co.	BL-80R	Touch Scanner (Read Width: 105mm)	Includes power supply.
Denso Co.	HC36TR	Touch Scanner (Read Width: 61mm)	For power: separately sold P-200 unit
	HC61TR	Touch Scanner (Read Width: 61mm)	For connector cable: separately sold KRS-423-XF1K (Sanwa Supply)

*1 Confirm that the Expansion serial interface's settings match those of the connected device.
See 6.4.6 Expansion Serial Communication Setup.

◆ Serial Code Reader (Connected to Expansion Serial Interface)

Manufacturer	Model	Power Supply
T ohken	THIR-3000	ESA-1220A (Sold separately)
	THIR-3000H	
Denso	QS20H	Supplied with the main unit
	QS20H-I	

*1 Confirm that the Expansion serial interface's settings match those of the connected device.
See 6.4.6 Expansion Serial Communication Setup.

◆ Speaker

Models to be connected to LINE OUT require a separate amplifier.

Manufacturer	Model	Connection Port
Arrow Electronics	NS-38	SP OUT , GND
	NS-105	

1.3 Accessories

All optional equipment listed here is produced by Digital Electronics Corporation.

■ Available Software

Product Name	Model No.	Description
Pro-Control Editor	GLCCNT-ED01W-V30	Logic program development software.
GP-PRO/PB III for Windows	GPW-PB01W-V50<CD-ROM>	Software to be used to create the GP's screen data using a personal computer.

■ Tool Connector

Product Name	Model No.	Description
Screen Data Transfer Cable	GPW-CB02	Connects the GP to a personal computer. Transfers screen data and user program(s).

■ Serial Interfaces

Product Name	Model No.	Description
RS-232C cable*1	GP410-IS00-O	Interface cables between the host (PLC) and the GP.
RS-422C cables*1	GP230-IS11-O	
	GP230-IS12-O (for Multi-link)	
RS-422C (Connector terminal block conversion adapter)	GP070-CN10-O	Conversion adapter to convert serial data to RS-422 format
2 Port Adapter II	GP070-MD11	Interface unit that allows use of both GP and Mitsubishi A, Q, C and FX series equipment in the same location.
2 Port Adapter II Cable	GP070-MDCB11	Connects the GP to 2 Port Adapter II.
Mitsubishi A Series Programming Port I/F cable	GP430-IP10-O	Connects directly to Mitsubishi's PLC I/F Programming Console. Simultaneous use of program console, however, is not possible.
Mitsubishi FX Series Programming Port I/F cable	GP430-IP11-O	

*1 For detailed information about range of connectable PLC.

Reference *GP-PRO/PBIII for Windows PLC Connection Manual*
(included with the GP screen creation software)

■ Printer Interface Cable

Product Name	Model No.	Description
Printer Cable	PSM-PRCB00	Cable designed to connect the GP and a commercial type printer.

Chapter 1 - Introduction

■ I/O Unit

Product name	Model	Content
Flex Network 16-point input sync source type I/O Unit	FN-X16TS11 FN-X16TS41	16-point sync source type shared I/O Unit. Sync source input circuit and its common (COM terminal) cabling.
Flex Network 8-point input sync source/8-point transistor output sync type I/O Unit	FN-XY08TS11 FN-XY08TS41	I/O Unit with mixed in/output of 8 point input sync source and 8-point transistor output sync type. Can be connected to supply voltage DC24V, load current 200mA electromagnetic bulb, pilot lamp for output.
Flex Network 8-point relay output/1 Common type I/O Unit	FN-Y08RL11 FN-Y08RL41	8-point relay output/1 common type I/O Unit. Can be connected to AC240V (1A) or DC24V(1A) load current.
Flex Network 16-point output sync type I/O Unit	FN-Y16SK41	16-point output sync type I/O Unit.
Flex Network 16-point output source type I/O Unit	FN-Y16SC41	16-point output source type I/O Unit.

■ Analog Unit

Product name	Model	Content
Flex Network 4-channel analog input Unit	FN-AD04AH11	Can store analog signal in this unit by changing it into 12 bit digital signal.
Flex Network 4-channel analog output Unit	FN-DA04AH11	Can operate to change 12-bit digital signal into analog signal inside this unit and output.

■ CF Card Items

Product Name	Model No.	Description
CF Cards*1	GP077-CF10	GLC Series CF Card (8MB)
	GP077-CF20	GLC Series CF Card (16MB)
CF Card Adaptor	GP077-CFAD10	CF Card Adaptor for standard PC Card Slot.



*1 The CF Memory Loader Tool and Backup Data require at least 8MB of CF Card memory. Use Digital's CF Card "GP077-CF20 (16MB)".

■ Screen Protection

Product Name	Model No.	Description
Screen Protection Sheet	PS400-DF00 (GP-2400T)	Disposable protective and dirtresistant sheet for the GLC's screen. The GLC's touch panel can be used with this cover sheet attached. (5 sheets/set)
Flex Network Communication Cable	FN-Cable 2050-31-MS (50m)	Communication cables that connect I/O Units and Analog Units or distributed I/O Units and Analog Units.
	FN-Cable2200-31-MS (200m)	

■ Maintenance Items

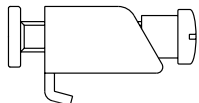
These are all original GLC standard equipment items. They are also available separately as optional maintenance items.

Product Name	Model No.	Description
Backlight 	PS400-BU00-MS (for GP-2400T)	Replacement Backlight
Installation Fastener 	GP070-AT01	Fasteners to attach the GLC to a panel. (4 fasteners/set)
Installation Gasket 	PS400-WP00-MS (for GP-2400T)	Provides a moisture resistant seal when installing the GLC. Same as the seal included in the GLC's original equipment package.
Connector Cover	PS-BH00	Protects GLC rear face connectors.

1.4 GLC2400 Series Overview

The GLC-2400-TC41-24V unit is equipped with a variety of new and useful features, such as an Ethernet, CF Card and Sound interfaces as standard equipment. The following explanation describes new GLC features.

■ Ethernet Feature

Your GLC2400 series unit comes with an Ethernet 10BASE-T connector as standard equipment. In addition to sending screen data to the GLC, this feature can also be used to set up the GLC, even if you are using the unit for the first time*1. Also, Digital's separately sold Pro-Server software can be used to read out data collected in the GLC to a central PC server, via an Ethernet LAN network. This collected data can then be processed for production information management, via a variety of popular software applications.

■ CF Card Feature

This interface allows you to use the CF Card instead of the optional Memory Loader II to store GLC setup*1 and screen data, and then transfer it to the GLC. You can also read and write data to your existing (optional) Multi-Unit's CF Card, since the GLC2400's card is the same type. The CF Card can also be used for the storage and transfer of recipe, logging, alarm history and bmp data files. The GLC can read these files from the CF Card, or use the CF Card to store data read out from the host (PLC).

■ Sound Output I/F

With the GLC2400, you only need to connect a speaker to the GLC's sound output Terminal to enable sound output, without connecting the optional Multi Unit.

■ Expansion Serial Interface

This interface allows you to connect a variety of equipment, including a bar-coder reader, a serial code reader or an I/O device.

■ Flex Network I/F

A high speed remote (6Mbps/12Mbps) interface capable of connecting a maximum of 1008 I/Os.

■ Internal 2-Port Feature

The GLC's built-in 2-Port feature allows you to enjoy 2-Port operation with a Mitsubishi brand PLC, without using the optional 2-Port Adapter II unit.

■ Backlight Burnout Detection Feature

When the GLC's backlight burns out, it will be automatically detected. The GLC's "Status LED" will alert you that the backlight is burned out so that you can disable GLC Touch Panel Operation and prevent a possible GLC operation mistake.

(Please read the following sections for detailed information about each feature.)

*1 *Setting up the GLC means downloading the required system and protocol programs from the GLC screen creation software to the GLC.*

1.4.1 Ethernet Connectivity

The GLC2400 can be connected to a LAN or an Ethernet compatible PLC. The GLC2400 also supports the 2-Way function. *1

This feature allows you to setup a GLC and to also perform screen data transfer. You can even set up a completely new GLC.

For details about setting up the GLC via an Ethernet network, refer to

Reference *GP-PRO/PBIII for Windows GP2400 Update Operation Manual*
(included with the GP2400 Update Kit CD-ROM)

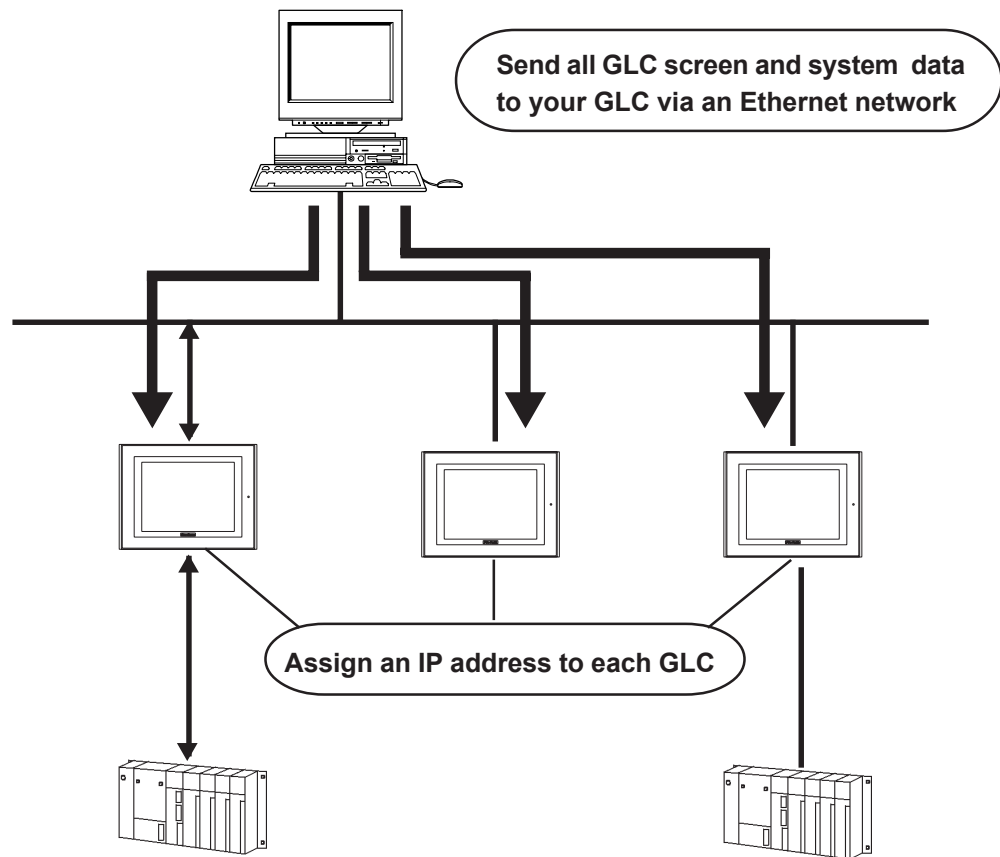

*1 To use this feature, Pro-face's "Pro-Server with Pro-Studio for Windows" software (sold separately) is required.

Chapter 1 - Introduction

1.4.2 CF Card

The new GLC2400 series unit allows you to use a CF Card. You can set up the GLC*1 or send screen data by saving backup data (i.e. all necessary data for GLC operation) in the CF Card using the GLC's CF Memory Loader Tool feature. As with the Multi Unit, all the following features are available with a GLC2400 series unit.

- Read filing data from CF Card
- Write logging data to CF Card
- Read image data or sound data from CF Card
- Write Graph data or Alarm data to CF Card
- Back up screen data to CF Card

For details about creating / saving backup data (i.e. all necessary data for GLC operation) and sending GLC data, refer to

Reference *GP-PRO/PBIII for Windows GP2400 Update Operation Manual (included with the GP2400 Update Kit CD-ROM)*

For details about CF Memory Loader Tool's data upload and download, refer to

Reference *4.3 CF Memory Loader Tool*



When using the "CF Memory Loader Tool", Digital's GP077-CF20 (16MB) Memory Card is required.

■ Send GLC Screen Data to a CF card, then to other GLCs

The CF Card allows you to set up multiple GLCs, using a single GLC's data.

Copy your GLC data and the "CF Memory Loader Tool" to your GLC's CF Card, then insert that CF Card in another GLC and transfer that data using the the CF Memory Loader Tool.

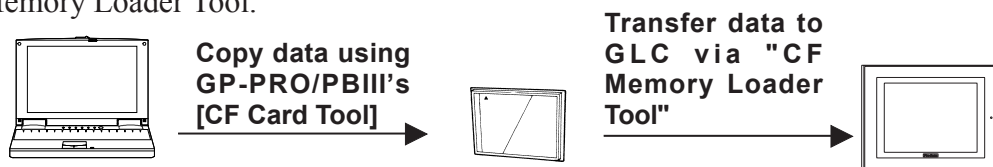

■ Send GLC Screen Data to a GLC, then to the CF card

You can also use the GLC as a CF Card drive for your PC, by sending data from your PC directly to your GLC's CF Card, . Simply connect your PC and the GLC using the data transfer cable, and send your backup data and the CF Memory Loader Tool to the CF Card installed in the GLC.

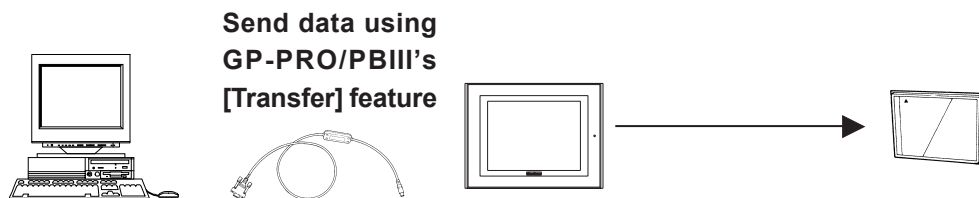

At a transmission speed of 115.2kbps, it takes approximately fifteen minutes to transfer screen and system data to a GLC.

**1 Setup means the sending of System and Protocol programs to the GLC unit via the screen creation software. This, in turn, allows you to use the GLC in the desired environment.*

■ Send Data from a GLC to a CF Card, then to another GLC

The CF Card allows you to use backup data saved in a GLC for setting up another GLC. First, upload (transfer) your GLC's backup data to your CF Card. Next, remove the CF Card, insert it in a different GLC and download (transfer) the CF Card's data to that GLC. Be sure that the CF Memory Loader Tool is saved on the CF Card prior to using this method.

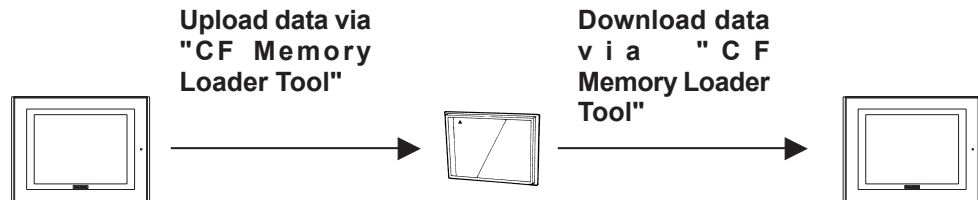

1.4.3 Sound Output

This feature allows you to connect a speaker to the GLC's Sound Output Terminal to produce sound output without using Pro-face's optional Multi Unit.

This feature can be used when an operator wishes to create a sound-alarm or a sound-message, rather than only checking alarms or messages via the GLC screen. It can be also used as a machinery operation guide, or for multimedia.

Reference *"GP-PRO/PBIII for Windows Tag Reference Manual" (included with the GP screen creation software package)*

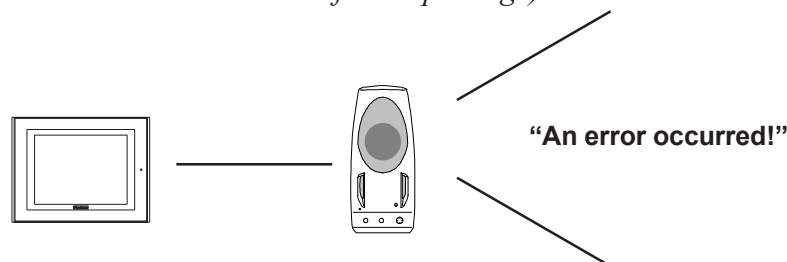

1.4.4 Expansion Serial I/F

The Expansion Serial Interface allows you to connect a bar-code reader, a serial-code reader, or other type of I/O device. It enables the input/output of large volumes of data which cannot be handled with a conventional bar code reader interface.

Also, connecting an I/O device requires the creation of a data transfer protocol (via the D-Script feature).

Reference *"GP-PRO/PBIII for Windows Operation Manual" (included with the GP screen creation software package)*

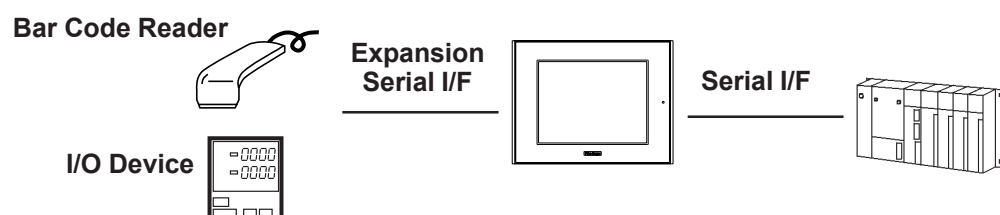

1.4.5 Flex Network I/F

The following information explains how to connect the GLC to a Flex Network I/F and I/O Unit.

When connecting the I/O unit, 2 channels are available - CH1 and CH2. Each channel outputs the same data and either can be used for data transmission.

The maximum number of connectable units, when using a single channel, is 31, and when using a second channel, the number increases by 32 to a total of 63.



The Flex Network uses high speed data transfer technology, and if a cable used for data transfer that is not the same as that specified in this document, network data transfer performance cannot be guaranteed. Thus, be sure to use only the cable(s) recommended here.

Reference Flex Network User Manual

Standard System Design

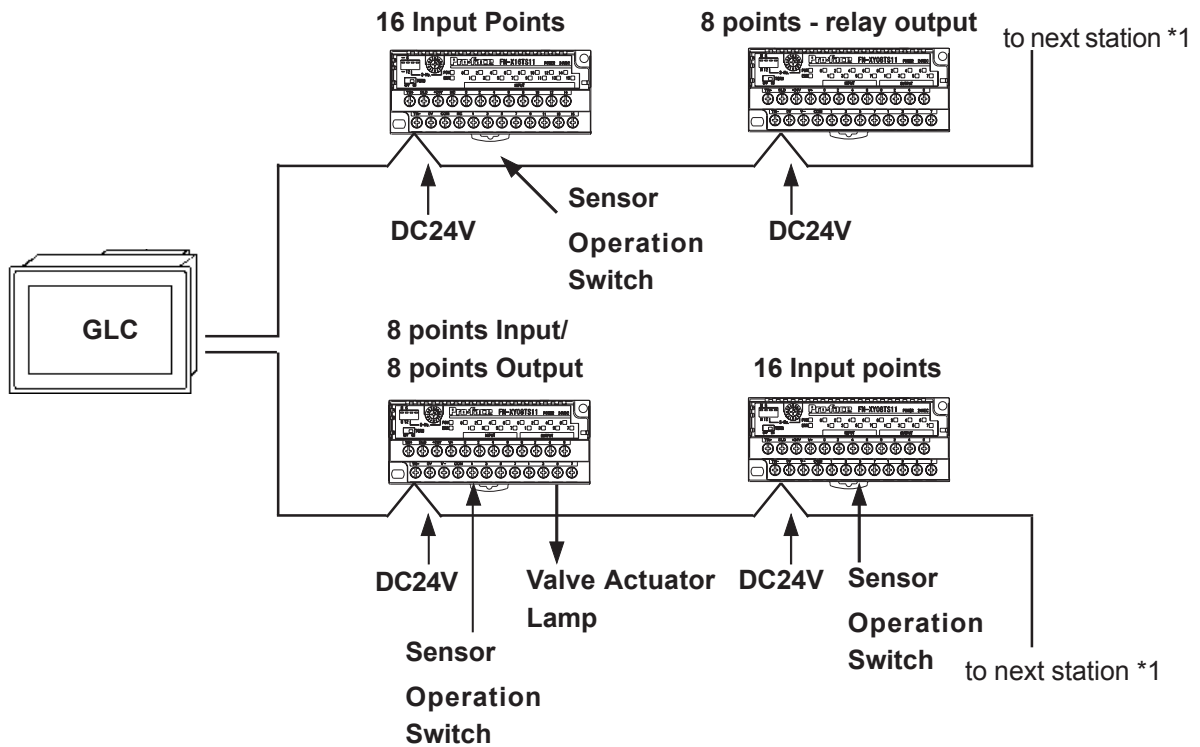

Note: 6Mbps is the recommended speed.

*1 Be sure the Terminal Switch (TERM) of the network's last unit (at each end) is turned ON.

Reference Flex Network User Manual

1.4.6 Printer/Serial Device/ Tool Connector Interface

■ Printer I/F

This interface is used to connect a printer to the GLC2400. Be sure to use the PSM-PRCB printer cable made by Digital Electronics Corporation.

Reference See 2.3.2 Printer I/F

■ Serial I/F

This interface is used to connect RS-232C and RS-422 interface cables to a host (PLC).

Reference See 2.3.1 Serial I/F

■ Tool Connector

This interface is used to connect a data transfer cable, a bar-code reader, and the Memory Loader II unit to the GLC2400.

Reference See 2.2.5 Tool Connector

1.4.7 Internal 2-Port Feature

The 2-Port feature allows you to use Mitsubishi's GPP software package (ladder programming software) on your PC while the GLC is connected to a PLC. With a GLC2400 Series unit, you can use the 2-Port feature in the following two ways:

- Via the internal 2-Port feature
The GLC's Tool Connector and a PC are connected via a data transfer cable (GPW-CB02).
- Via the external 2-Port Adapter II
Pro-face's 2-Port Adapter II (GP070-MD11) is used.

For information about PLC types and GLC compatibility with GLC2400 Series units, refer to **Reference** *GP-PRO/PBIII for Windows PLC Connection Manual* (included with the GP screen creation software)

■ When Using Internal 2-Port feature ^{*1}

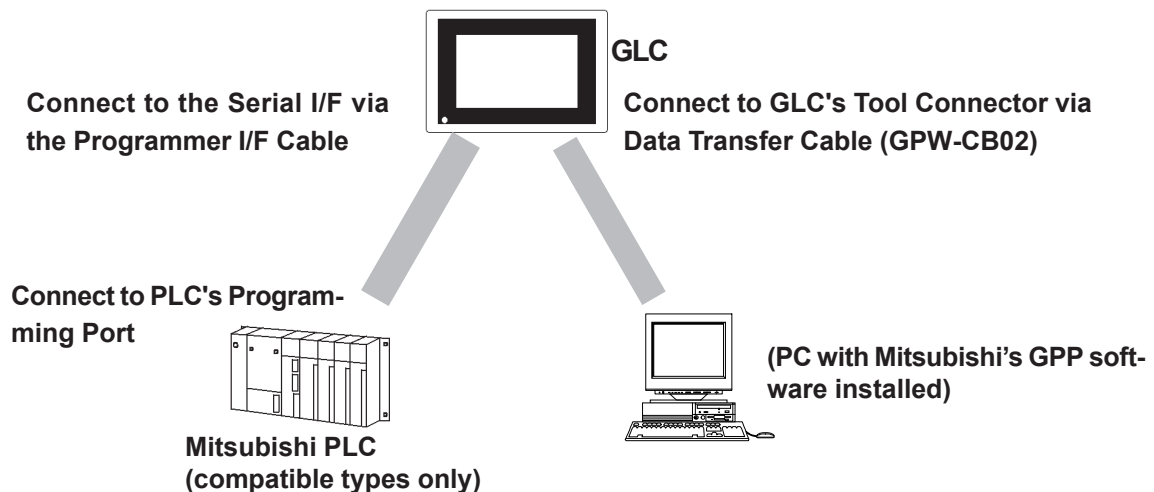

Chapter 1 - Introduction

■ When Using the External 2-Port Adapter *2

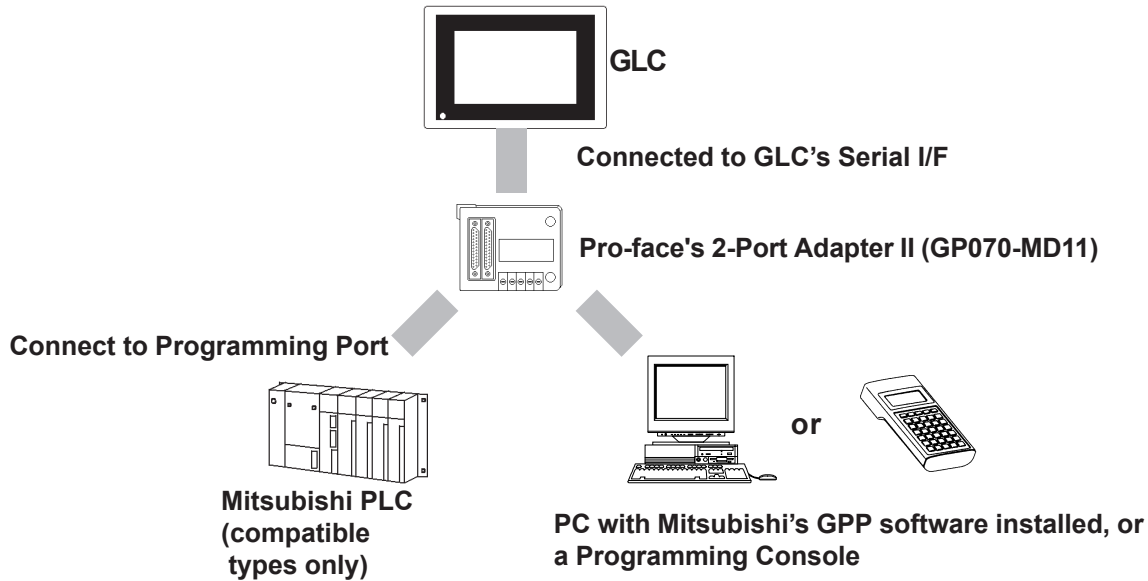

■ Internal 2-Port Feature Usage Notes

- To use the Internal 2-Port feature, you will need to adjust your GLC's settings. For information about these settings, refer to **Reference** *GP-PRO/PBIII for Windows PLC Connection Manual (included with the GP Screen creation software)*
- This feature can be used only while the GLC is in ONLINE mode.
- Since the internal 2-Port feature uses the GLC's single tool connector, you will not be able to use equipment which requires the tool connector (i.e. a Barcode Reader, Optional Items, etc.)
- If you transfer screen data while the GLC is in ONLINE mode, the screen will not change to the data transfer screen automatically. Thus, you will need to change the screen manually to the OFFLINE mode's [Main Menu/ Transfer] screen.
Reference *4.1 Serial Data Transfer*
- Peripheral equipment, such as a Programming Console, is not compatible with the GLC's Internal 2-Port feature. To use this type of equipment, you will need to use the external 2-Port Adapter II.

*1 The Device Monitor feature can also be used at the same time. For details about the device monitor function, refer to **Reference** *GP-PRO/PBIII for Windows PLC Connection Manual (included with the GP screen creation software)*

*2 GLC2400 Series units can also use the 2-Port Adapter II. For details, refer to **Reference** *GP-PRO/PBIII for Windows PLC Connection Manual (included with the GP screen creation software)*

1.4.8 Backlight Burnout Detection Feature

When the GLC's backlight burns out, it will be automatically detected. The GLC's Status LED will alert you that the backlight is burned out so that you can disable GLC Touch Panel Operation and prevent a possible GLC operation mistake.

When Backlight Burnout is detected the GLC's Status LED will turn orange. Also, the system data area's "Status" bit10 *1 will turn ON.

Reference For details about touch panel operation when the backlight burned out, refer to **6.4.3 Touch Panel Settings**.



Since the GLC monitors current consumption to detect if the backlight has burned out, in certain cases detection may not be possible.



When a major logic program error occurs, depending on the type of error, the LED turning red can become a priority.

In some cases, even though a backlight burnout has been detected, the backlight may remain faintly lit. In this case, please change the backlight as quickly as possible.

*1 When using the Direct Access method, bit +6 will turn ON. The using Memory Link method, bit 11 will turn ON. For details, refer to **Reference** **GP-PRO/PBIII for Windows PLC Connection Manual** (included with the GP screen creation software)

Memo

Chapter

2 Specifications

1. General Specifications
2. Functional Specifications
3. Interface Specifications
4. Part Names and Functions
5. Dimensions

2.1 General Specifications

2.1.1 Electrical

■ GLC-2400-TC41-24V

Input Voltage	DC 24V
Rated Voltage	DC19.2V to DC28.8V
Allowable Voltage Drop	10ms or less
Power Consumption	28W or less
In-Rush Voltage	30A or less
Voltage Endurance	AC1000V 20mA for 1 minute (between charging and FG terminals)
Insulation Resistance	DC500V at 10M Ω or higher (between charging and FG terminals)

Chapter 2 - Specifications

2.1.2 Environmental

Ambient Operating Temperature	0°C to +50°C
Storage Temperature	-20°C to +60°C
Ambient Humidity	10%RH to 90%RH (Non condensing, dry bulb temperature: 39°C or less)
Dust	0.1mg/m ³ or less (non-conductive levels)
Atmosphere	Free of corrosive gasses
Atmospheric Endurance (GLC Operation Altitude)	800hPa to 1114hPa (2000 meters or lower)
Shock Resistance	IEC6111-2 (JIS B 3501) compliant 147m/s ² Release time 11ms Twice in each of X, Y, Z directions
Vibration Resistance	IEC6111-2 (JIS B 3501) compliant When vibration is NOT continuous 10Hz to 57Hz 0.075mm, 57Hz to 150Hz 9.8m/s ² When vibration is continuous 10Hz to 57Hz 0.035mm, 57Hz to 150Hz 4.9m/s ² X, Y, Z directions for 10 times (80min.)
Noise Immunity (via noise simulator)	Noise Voltage: 1500Vp-p, Pulse Duration: 1ms Rise Time: 1ns
Electrostatic Discharge Immunity	Contact Discharge Method 6kV (complies with IEC 61000-4-2 Level 3)

2.1.3 Structural

Grounding	100Ω or less, or your country's applicable standard
Ratings *1	Equivalent to IP65f (JEM 1030) NEMA#250 Type4X/12
External Dimensions	W215mm [8.46in] x H170mm [6.69in] x D60mm [2.36in]
Weight	1.7 kg (3.7lb) or less
Cooling Method	Natural air circulation

**1 The front face of the GLC unit, installed in a solid panel, has been tested using conditions equivalent to the standards shown in the specification. Even though the GLC unit's level of resistance is equivalent to these standards, oils that should have no effect on the GLC can possibly harm the unit. This can occur in areas where either vaporized oils are present, or where low viscosity cutting oils are allowed to adhere to the unit for long periods of time. If the GLC's front face protection sheet becomes peeled off, these conditions can lead to the ingress of oil into the GLC and separate protection measures are suggested. Also, if non-approved oils are present, it may cause deformation or corrosion of the front panel's plastic cover. Therefore, prior to installing the GLC be sure to confirm the type of conditions that will be present in the GLC's operating environment. If the installation gasket is used for a long period of time, or if the unit and its gasket are removed from the panel, the original level of the protection cannot be guaranteed. To maintain the original protection level, you need to replace the installation gasket regularly.*

2.2 Functional Specifications

2.2.1 Display

Type	TFT type color LCD	
Colors	256 colors ^{*1} (depends on GP-PRO/PBIII version used)	
Resolution	640 x 480pixels	
Effective Display Area	W149.8mm [5.90in.] x H112.3mm [4.42in.]	
Language Fonts	ASCII: (Code page 850) Alphanumeric (incl. Eur. characters) Chinese: (GB2321-80 codes) simplified Chinese fonts Japanese: ANK 158, Kanji : 6962 (JIS Standards 1 & 2) Korean: (KSC5601 - 1992 codes) Hangul fonts Taiwanese: (Big 5 codes) traditional Chinese fonts	
Text	8x8 dots	80 Char. x 60 rows
	8x16 dots	80 Char. x 30 rows
	16x16 dots	40 Char. x 30 rows
	32x32 dots	20 Char. x 15 rows
Font Sizes	Both height and width can be expanded 1, 2, 4, or 8 times.	
Touch Panel	32 x 24 keys/ screen (1 or 2 point touch)	
Display Sizes ^{*2}	8X8 dot font, 8X16 dot font, 16X16 dot font and 32X32 dot font	
Backlight	CFL (Service life: 50,000 hrs. or more at 25°C and 24hr. operation)	
Brightness Control	4 levels of adjustment available via touch panel.	

**1 Changing the “Colors” setting to “256 colors” will disable the blink feature on all of your project’s screens. If you wish to use the blink feature, do not change this setting to “256 colors”.*

**2 The display font will differ depending on which (language) character, or which size you select. Also, if the GP-PRO/PBIII Ver. 5.0 software is used, high quality fonts are available with 16x16 or larger characters.*

▼Reference▲ Chapter 6.8 SET UP SCREEN

Chapter 2 - Specifications

2.2.2 Memory

Application	4MB FLASH EPROM (Approx. 1280 screens at 3.2KB/screen)
Data Backup	256KB SRAM (uses lithium battery)* ¹

2.2.3 Control Memory

SRAM Back Up (Back Up Memory)	224KB SRAM (uses lithium battery)* ¹
--	---

*1 A Lithium battery's lifetime is:

10 years when the battery's ambient temperature is under 40 °C

4.1 years when the battery's ambient temperature is under 50 °C

1.5 years when the battery's ambient temperature is under 60 °C

When used for backup:

Approximately 60 days, with a fully charged battery

Approximately 6 days, with a half-charged battery

2.2.4 Clock

Clock Accuracy	<u>+ 65</u> seconds/month (at room temperature)
-----------------------	---



Note:

The GLC's internal clock has a slight error. At normal operating temperatures and conditions, with the GLC operating from its lithium battery, the degree of error is 65 seconds per month. Variations in operating conditions and battery life can cause this error to vary from -380 to +90 seconds per month. For systems where this degree of error will be a problem, the user should be sure to monitor this error and make adjustments when required.

2.2.5 Interfaces

Serial Interface	Asynchronous Transmission: RS232C/RS422 Data Length: 7 or 8 bits Stop Bit: 1 or 2 bits Parity: None, Odd or Even Data Transmission Speed: 2400 to 115.2kbps																		
Expansion Serial Interface	Asynchronous Transmission: RS232C Data Length: 7 or 8 bits Stop Bit: 1 or 2 bits Parity: None, Odd or Even Data Transmission Speed: 2400 to 115.2kbps																		
Ethernet Interface	IEEE802.3, 10BASE-T																		
Tool Connector	Asynchronous TTL level nonprocedural command I/F <During screen file development> Used for transferring data to and from the GP application software and the GP. Used for data transfer with the 2-Port feature. <During Operation> Used for a variety of devices, including a bar-code reader.																		
CF Card Interface	1 slot																		
Printer Interface	Compatible with NECPC-PR201/PL , EPSON ESC/P24-J84(C), HP Laser Jet PCL 4 command compatible printers *1																		
Screw Lock Terminal Block	<table border="0"> <tr> <td>AUX Input/Output</td> <td>Remote Reset Input</td> <td>1 point</td> </tr> <tr> <td></td> <td>Input Voltage</td> <td>DC24V +10%</td> </tr> <tr> <td></td> <td>Input Current</td> <td>4mA (TYP)</td> </tr> <tr> <td></td> <td>Min. Input Pulse Width</td> <td>2ms</td> </tr> <tr> <td></td> <td>Operating Voltage</td> <td>(When ON) Min. DC21.1V (When OFF) Max. DC3V</td> </tr> <tr> <td></td> <td>Isolation Method</td> <td>Photocoupler Isolation</td> </tr> </table>	AUX Input/Output	Remote Reset Input	1 point		Input Voltage	DC24V +10%		Input Current	4mA (TYP)		Min. Input Pulse Width	2ms		Operating Voltage	(When ON) Min. DC21.1V (When OFF) Max. DC3V		Isolation Method	Photocoupler Isolation
	AUX Input/Output	Remote Reset Input	1 point																
		Input Voltage	DC24V +10%																
	Input Current	4mA (TYP)																	
	Min. Input Pulse Width	2ms																	
	Operating Voltage	(When ON) Min. DC21.1V (When OFF) Max. DC3V																	
	Isolation Method	Photocoupler Isolation																	
Flex Network I/F	Communication Style: 1:N Connection Format: Multi Drop Connection Communication Range: 200m/CH at 6Mbps, 100m/CH at 12Mbps Communication Format: Cyclic Data Transfer, Half-duplex Communication Speed: 6Mbps, 12Mbps Communication I/F: Differential method, Pulse Transformer Insulation method Error Check: Format Test, Bit Test, CRC-12 Test Number of connection stations: Maximum 63 stations Number of I/O points: 1008																		
Sound Output	External Speaker Connection (Terminal Block) Monaural 1CH Speaker Output 70mW (Rated Load: 8Ω, Frequency: 1kHz) Sound Line Out Output 2.7Vp-p (Rated Load: 10kW) Recommended wire: AWG#28 to #16																		

*1 Printers with only Windows drivers cannot be used. However, certain types of printers with both Windows and DOS drivers can be used. For details, contact your local GLC distributor.

2.3 Interface Specifications

2.3.1 Serial Interfaces

This interface can be either RS-232C or RS-422. Connects GLC to Host (PLC).

Pin Assignments	Pin #	Signal Name	Condition
<p>(D-Sub 25pin female)</p> <p>SIO</p>	1	FG	Frame ground
	2	SD	Send data (RS-232C)
	3	RD	Receive data (RS-232C)
	4	RS	Request send (RS-232C)
	5	CS	Clear send (RS-232C)
	6	DR	Data Set Ready (RS-232C)
	7	SG	Signal ground
	8	CD	Carrier detect (RS-232C)
	9	TRMX	Termination (RS-422)
	10	RDA	Receive data A (RS-422)
	11	SDA	Send data A (RS-422)
	12	NC	No connection (Reserved)
	13	NC	No connection (Reserved)
	14	VCC	5V±5% output 0.25A
	15	SDB	Send data B (RS-422)
	16	RDB	Receive data B (RS-422)
	17	RI	Ring Indicate (RS-232C)
	18	CSB	Clear send B (RS-422)
	19	ERB	Enable receive B (RS-422)
	20	ER	Enable receive (RS-232C)
	21	CSA	Clear send A (RS-422)
	22	ERA	Enable receive A (RS-422)
	23	NC	No connection (Reserved)
	24	NC	No connection (Reserved)
	25	NC	No connection (Reserved)

Recommended Connector: Dsub25pin plug XM2A-2501 <made by OMRON>

Recommended Cover: Dsub25pin cover XM2S-2511 <made by OMRON>

Jack Screws: XM2Z-0071 <made by OMRON>



- Use rough metric type M2.6x0.45 p threads used to secure the cable's set screws.
Recommended Cable: CO-MA-VV-SB5PX 28AWG <made by HITACHI Cable Ltd.>

- To confirm your PLC's connection specifications, refer to

Reference *GP-PRO/PBIII for Windows PLC Connection Manual (included with the screen creation software)*

When creating your own cable, follow the instructions listed below:

<With RS-422>



- The following pairs of pin #'s must be connected to each other.

#18 (CSB) <—> #19 (ERB)

#21 (CSA) <—> #22 (ERA)

- When connecting the RS-422 cable and the #9 (TRMX) and #10 (RDA) points, a termination resistance of 100Ω is added between RDA and RDB.
- When making a cable for a Memory Link system, be sure to use a 4-wire type.

<With RS-232C>

- Do not use the following pins: 9 (TRMX), 10 (RDA), 11 (SDA), 15 (SDB), 16 (RDB), 18 (CSB), 19 (ERB), 21 (CSA), 22 (ERA).
- The #1 (FG) terminal should only be connected if it is required by the device being connected to.



- This unit's serial port is not isolated, therefore, it is important that you connect the SG (Signal Ground) terminals. If this is not done, the RS422 circuit may be damaged.***
- Pin 14 (VCC) DC5V output is not protected. To prevent damage or unit malfunction, be sure to use only the designated level of current.***

■ Expansion Serial Interface

This interface is used for RS-232C data transfer.

Pin Assignments	Pin No.	Signal Name	Signal Direction	Condition
(D-Sub 9pin male) 	1	CD	Input	Carrier detect (RS-232C)
	2	RD	Input	Receive data (RS-232C)
	3	SD	Input	Send data (RS-232C)
	4	ER	Output	Enable receive (RS-232C)
	5	SG	—	Signal Ground
	6	DR	Input	Data Set Ready (RS-232C)
	7	RS	Output	Request Send (RS-232C)
	8	CS	Input	Clear send (RS-232C)
	9	RI/VCC	Input/Output	Ring Indicate (RS-232C) +5V+5% 0.25A

Recommended Connector: Dsub9pin socket XM2D-0901<made by OMRON>

Recommended Cover: Dsub9pin cover XM2S-0913<made by OMRON>

Jack Screws: #4-40 UNC<made by OMRON>

Use inch type screws (#4-40UNC) as set screws.



Since Pin#9(RI/VCC) is unprotected, be sure to keep the output current in the rated range.

Chapter 2 - Specifications

2.3.2 Printer Interface

When connecting a printer, use Digital's printer cable (PSM-PRCB00).

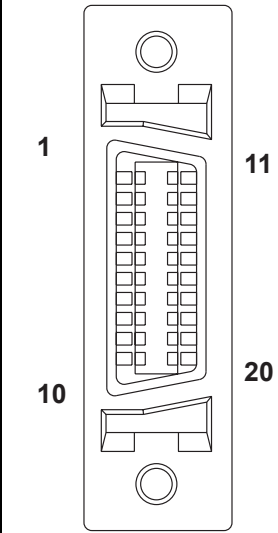
Pin Assignments	Pin #	Signal Name	Condition
	1	GND	Ground
	2	RESERVE	Reserved
	3	PDB5	Data Signal
	4	PDB4	Data Signal
	5	PDB3	Data Signal
	6	GND	Ground
	7	SLCT	Select Status (Input)
	8	PDB0	Data Signal
	9	$\overline{\text{PSTB}}$	Strobe Signal (Output)
	10	BUSY	Busy Signal (Input)
	11	PDB7	Data Signal
	12	PDB6	Data Signal
	13	GND	Ground
	14	ERROR	Printer Error (Input)
	15	GND	Ground
	16	PDB2	Data Signal
	17	PDB1	Data Signal
	18	PE	Paper Runout
	19	$\overline{\text{INIT}}$	Initialization Signal (Output)
	20	GND	Ground

2.3.3 AUX I/F, Flex Network I/F and Sound Output I/F

This interface is used for external reset, Flex Network, or sound output.

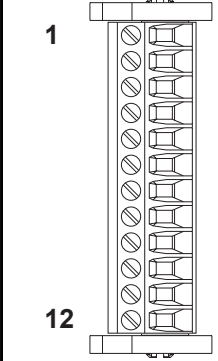
Pin Assignments	Pin #	Signal Name	Condition
	1	AUXCOM	External Reset Common
	2	AUXRESET	External Reset Input
	3	TR+	CH1 Communication Data
	4	TR-	CH1 Communication Data
	5	SLD	CH1 Cable Shield Line
	6	TR+	CH2 Communication Data
	7	TR-	CH2 Communication Data
	8	SLD	CH2 Cable Shield Line
	9	RESERVE	Reserve
	10	SP OUT	Speaker Output
	11	GND	Ground
	12	LINE OUT	Sound Lineout Output

2.4 Part Names and Functions

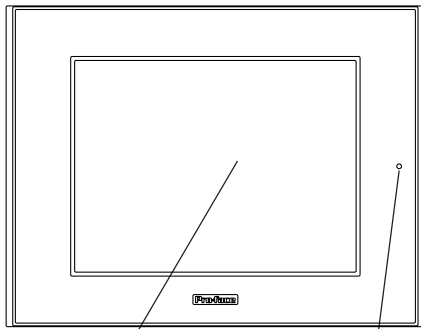

A,B
Front
(all units)

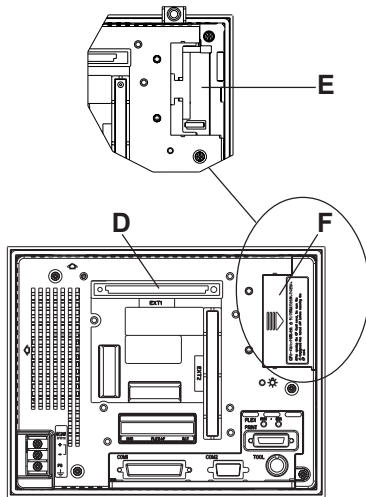

Rear
(GLC2400T)

A: Display Panel

The GLC monitor screen displays the screen setup and corresponding host (PLC) data.

(All units)

B: Touch Panel

Performs any screen change operations and sends data to the PLC.

C: Status LED

Indicates the GLC's current condition.

Color	Indicator	Operation Mode	Controller Operation Mode
Green	ON	OFFLINE	---
	ON	In operation	RUN
	Flashing	In operation	STOP
Red	ON	In operation	Major Error

Color	Indicator	Meaning
Orange	ON	Backlight burnout has occurred.

D: Expansion Unit I/F *1

Connects a data communication expansion unit to the GLC. (currently disabled)

E: CF Card I/F

Insertion slot for CF Card.

F: CF Card Cover

Protects the CF Card interface and the CF Card from contamination. When opened, the GLC unit's Dip Switches can be seen.

*1 Interface units for this interface are currently under development.

Chapter 2 - Specifications

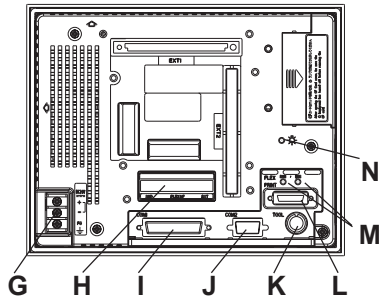

Rear
(GLC2400T)

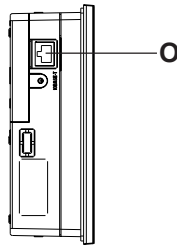

Side
(GLC-2400T)

G: Power Input Terminal Block

Connect Power Cord.

H: Screw Lock Terminal Block

Used for external reset, alarm output, buzzer output, and sound output.

I: Serial I/F

RS-232C/422 Interface. Connects to the host PLC.

J: Expansion Serial I/F

RS-232C Interface.

K: Tool Connector

Connects to Transfer Cable, Bar Code Reader or Memory Loader II.

L: Printer Interface

Connect the printer cable here. Recommended cable: Digital Electronic Corporation PSM-PRCB00 Cable.

M: Flex Network I/F

Flex Network I/F status LED will turn ON or flash, according to the unit's status.

Status LED	Contents
RUN (Green)	Turns on when Communication is enabled.
ERR (Red)	Turns on when failure occurs in connected I/O Unit.

N: CF Card Access LED

If the CF Card Cover is closed when the CF Card is inserted, the LED lamp turns ON. The LED lamp will remain turned ON even if the CF Card Cover is opened while the GLC accesses the CF Card.

O: Ethernet Interface

Used for Ethernet (10BASE-T).

The LED will change (turn ON, blink) according to the GLC's status.

Status LED	Display	Contents
Orange	ON	Power ON
	Flash	Send/Receive
Green	ON	Link

2.5 Dimensions

2.5.1 GLC-2400T External Dimensions

Unit: mm [in.]

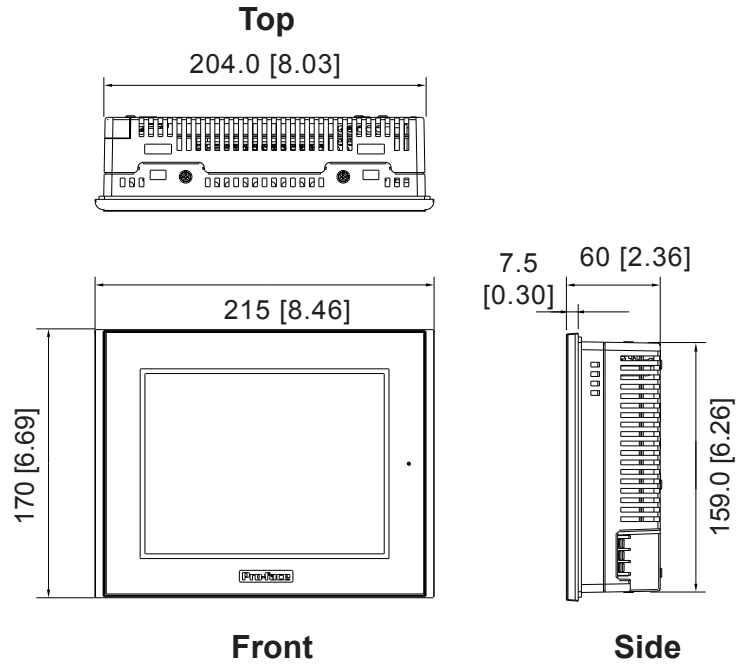

2.5.2 Installation Fasteners

Unit: mm [in.]

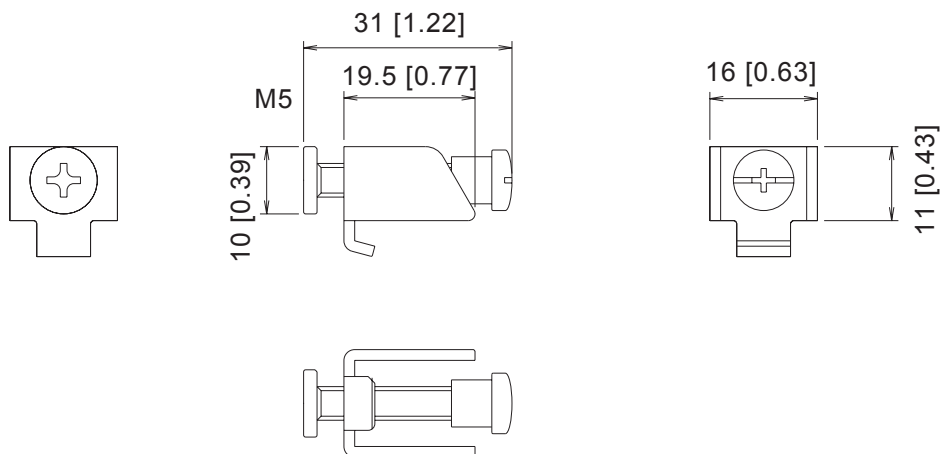

Chapter 2 - Specifications

2.5.5 Panel Cut Dimensions

■ GLC-2400T

Unit: mm [in.]

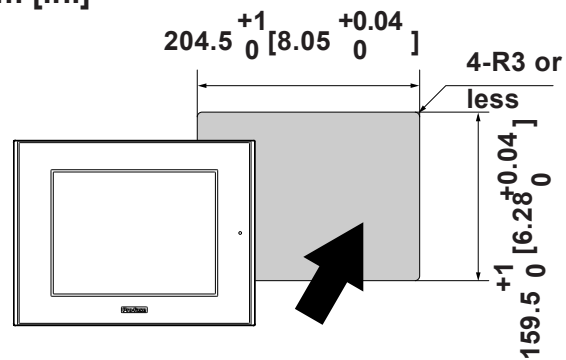

Chapter

3 Installation and Wiring

1. Installation

2. Wiring Cautions

3. Tool Connector

4. Ethernet Cable Connector

5. CF Card Insertion and Removal

6. Connecting to the Screw Lock Terminal

3.1 Installation

3.1.1 Installation Procedures

Follow the steps given below when installing the GLC.

■ Check the Installation Gasket's Seating

It is strongly recommended that you use the installation gasket, since it absorbs vibration in addition to repelling water.

Place the GLC on a level surface with the display panel facing downward. Check that the GLC's installation gasket is seated securely into the gasket's groove, which runs around the perimeter of the panel's frame.

For details about installing the gasket, refer to

▼ **Reference** ▲ *8.1.2 Installation Gasket Check/Replacement*

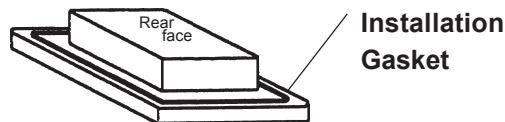

- **Before installing the GLC into a cabinet or panel, check that the Installation gasket is securely attached to the unit.**
- **A gasket which has been used for a long period of time may have scratches or dirt on it, and could have lost much of its dust and drip resistance. Be sure to change the gasket periodically, or when scratches or dirt become visible.**

Chapter 3 - Installation and Wiring

■ Creating a Panel Cut

Create the correct sized opening required to install the GLC, using the installation dimensions given.

▼ **Reference** 2.5.4 GLC Panel Cut Dimensions

The installation gasket, installation brackets and attachment screws are all required when installing the GLC.

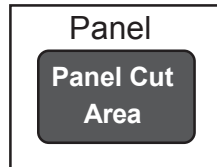

Check that the installation panel or cabinet's surface is flat, in good condition and has no jagged edges. Also, if desired, metal reinforcing strips can be attached to the inside of the panel, near the Panel Cut, to increase the panel's strength.



Panel thickness should be from 1.6mm [0.06in.] to 10mm [0.4in.]. Decide the panel's thickness based on the level of panel strength required.

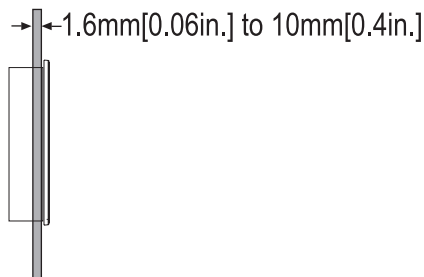

For easier maintenance, operation, and improved ventilation, be sure to install the GLC at least 100 mm [3.94in.] away from adjacent structures and other equipment.

Unit: mm[in.]

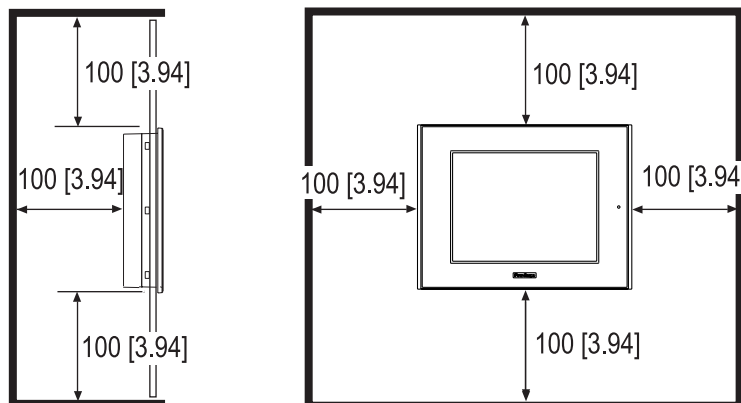

Chapter 3 - Installation and Wiring



- **Be sure that the ambient operation temperature and the ambient humidity are within their designated ranges. (When installing the GLC in a cabinet or enclosure, the term “ambient operation temperature” indicates the cabinet or enclosure’s internal temperature.**
- **Be sure that heat from surrounding equipment does not cause the GLC to exceed its standard operating temperature.**
- **When installing the GLC in a slanted panel, the panel face should not incline more than 30°.**

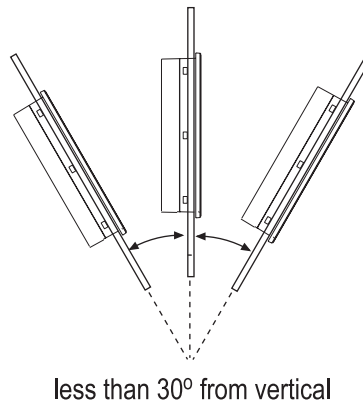

- **When installing the GLC in a slanted panel, and the panel face inclines more than 30°, the ambient temperature must not exceed 40 °C. You may need to use forced air cooling (fan, A/C) to ensure the ambient operating temperature is 40 °C or below.**
- **When installing the GLC vertically, position the unit so that the Power Input Terminal Block is also vertical.**

Chapter 3 - Installation and Wiring

■ Installing the GLC

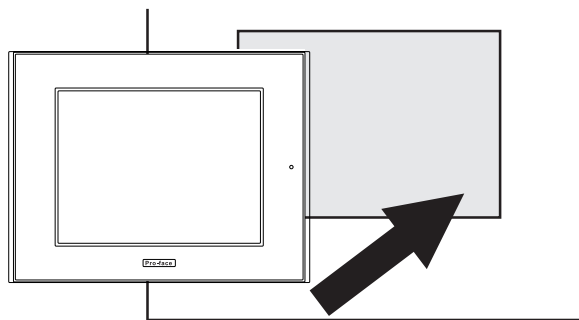

- 1) Insert the GLC into the panel cut out, as shown here.

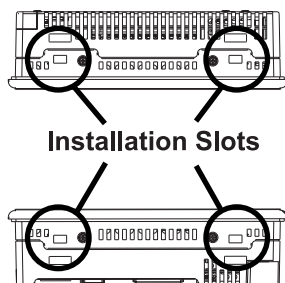

- 2) Insert the installation fasteners into the GLC's insertion slots, at the top and bottom of the unit.
(total: 4 slots)

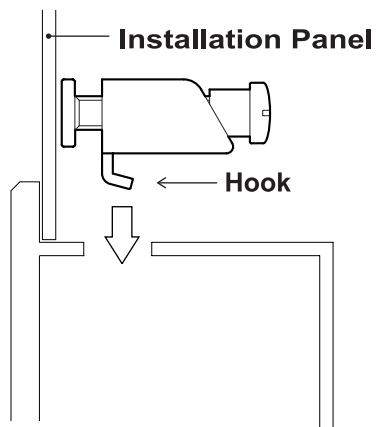

Chapter 3 - Installation and Wiring

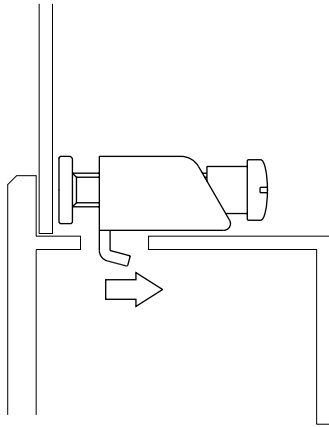

- 3) Insert each of the fasteners shown below. Be sure to pull the fastener back until it is flush with the rear of the attachment hole.

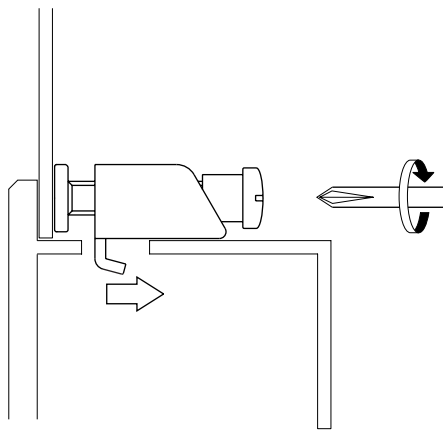

- 4) Use a Phillips screw driver to tighten each fastener screw and secure the GLC in place.



A torque of only 0.5 to 0.6 N•m is sufficient to tighten these screws. Excessive force may damage the GLC unit.

3.2 Wiring Cautions

3.2.1 Connecting the Power Cord



WARNINGS

- To avoid an electric shock, be sure the power cord is unplugged from the power outlet when connecting the power terminals to the GLC unit.
- The GLC2400-TC41-24V requires a DC24V supply. If the power supply does not match the model, both the power supply and GLC unit will be damaged.
- Since the GLC is not equipped with the power switch, be sure to connect a breaker type power switch to the GLC's power cord.
- The FG terminal must be connected to earth. This is to protect against electrical shock when the unit breaks down.



- *To prevent the Ring Terminals from causing a short when the terminal block attachment screws are loosened, be sure to use sleeve-type Ring Terminals.*
- *When the FG terminal is connected, be sure the wire is grounded. Not grounding the GLC unit will result in excessive noise. Use your country's applicable standard for grounding.*



- Wherever possible, use thick wires (max 2mm²) for power terminals, and twist the exposed wire ends when connecting the Ring Terminals.
- Please use the following size crimp-on type Ring Terminals.

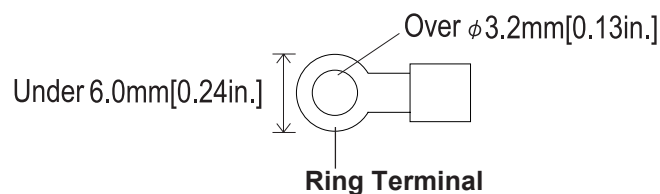

■ Connecting the Power Supply Terminals

◆ GLC2400-TC41-24V Unit

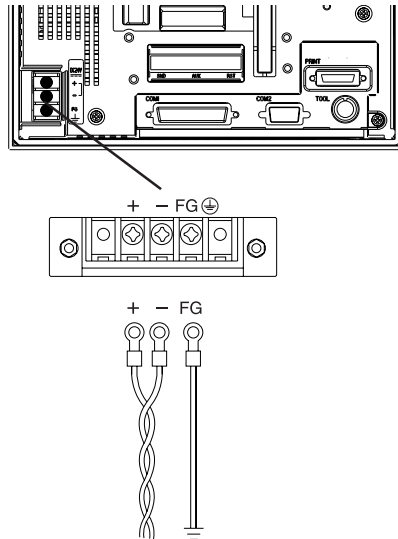

+	Positive electrode
-	Negative electrode
FG	Grounding Terminal connected to the GP chassis.

- 1) Be sure that the GLC's power cord is not plugged in to the power supply.
- 2) Remove the Terminal Strip's clear plastic cover.
- 3) Remove the screws from the three (3) middle terminals, position the Ring Terminals as shown above and reattach the screws. (Check each wire to make sure the connections are correct)



- **Confirm that the Ring Terminal Cable is connected to the correct connector.**
- **A torque of only 0.5 to 0.6 N•m is required to tighten an attachment screw.**

- 4) Reattach the Terminal Strip's clear plastic cover.

Chapter 3 - Installation and Wiring

3.2.2 Connecting the Power Supply

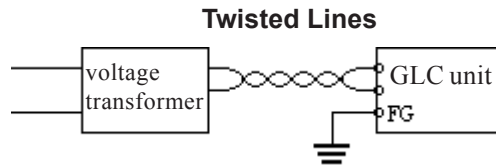

- If the supplied voltage exceeds the GLC unit's range, connect a voltage transformer.

Reference Chapter 2 Specifications for the allowable voltage range.

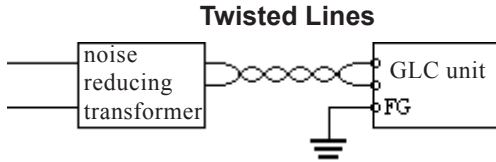

- For between the line and ground, select a power supply that is low in noise. If there is an excess amount of noise, connect a noise reducing transformer.

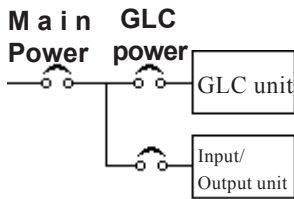

Use Voltage and Noise Reducing transformers with capacities exceeding 100VA.

- When supplying power to the GLC unit, please separate the input/output and operation unit lines, as shown.

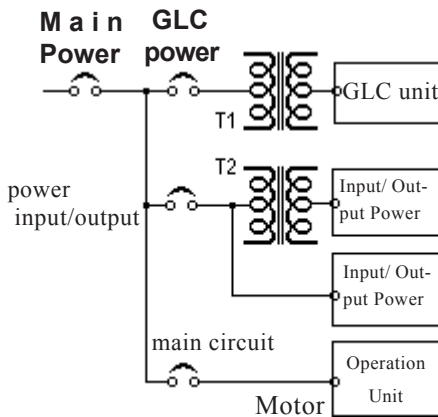

- To increase the noise resistance quality of the power cable, simply twist each power wire before attaching the Ring Terminal.
- The power supply cable must not be bundled or positioned close to main circuit lines (high voltage, high current), or input/output signal lines.

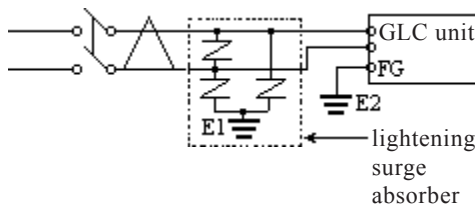

- Connect a lightning surge absorber, as shown in the diagram, to deal with power surges.
- To avoid excess noise, make the power cable as short as possible.



- **Be sure to ground the surge absorber (E1) separately from the GLC unit (E2).**
- **Select a surge absorber that has a maximum circuit voltage greater than that of the peak voltage of the power supply.**

3.2.3 Grounding



CAUTION

Do not use common grounding, since it can lead to an accident or machine breakdown.

(a) Exclusive Grounding (BEST) *1

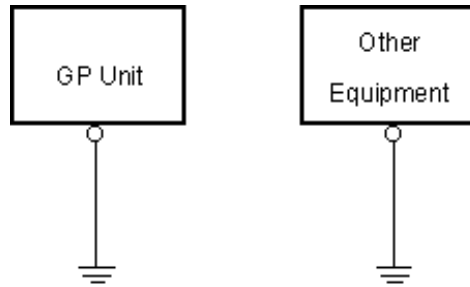

Connect the FG terminal found at the back of the GLC to an exclusive ground. [diagram (a)].

- **Check that the grounding resistance is less than 100Ω.**
- **The grounding wire should have a cross sectional area greater than 2mm². Create the connection point as close to the GLC unit as possible, and make the wire as short, as possible. When using a long grounding wire, replace the thin wire with a thicker wire, and place it in a duct.**

(b) Common Grounding (OK) *1

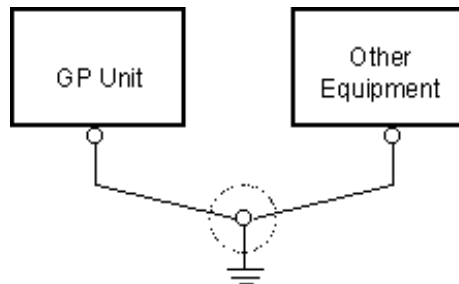

(c) Common Grounding (Not OK)

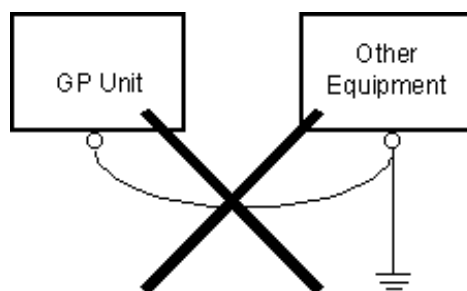

If exclusive grounding is not possible, use a common connection point. [diagram (b)]

If the equipment does not function properly when grounded, disconnect the ground wire from the FG terminal.

Chapter 3 - Installation and Wiring

3.2.4 I/O Signal Line Cautions

Separating all communication lines from power lines by placing them in a separate duct will help to prevent problems from noise and interference.

Duct for Communication Lines

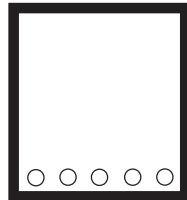

Duct for Power Lines

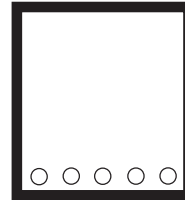

If the wires must be placed in the same duct, separate them via an earthed/grounded divider.

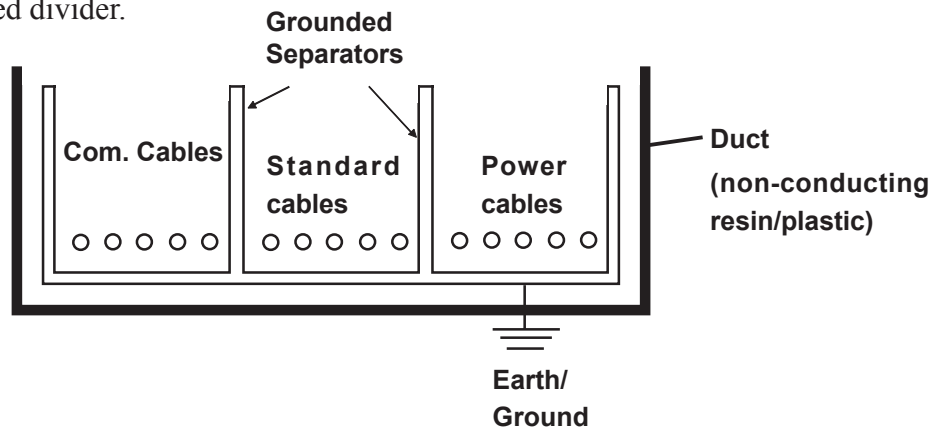

Note: When you are unable to separate the cables as shown above, be sure to use shielded cable and create a ground from the shield line.

3.2.5 Installation Cautions

A problem in the external power supply or a failure in the GLC Unit can lead to operation failures.

To prevent these failures, which can affect the entire system, and for fail-safe reasons, a prevention circuit (Emergency Stop Circuit, Protection Network, Interlock Circuit and System Design Circuit, etc.) should be used in areas where potential failures may occur.

The following are examples of prevention circuits that ensure reliability of the system.

■ Failsafe Electrical Circuits

When designing the fail-safe circuit, consider a possible malfunction due to the time difference between the start up time of control device (especially the DC power supply) connected to GLC output unit, the start up time of GLC system unit and program start up time. When using a remote I/O, create a logic program to check the terminal status.

For example, connect an electrical voltage relay coil to the GLC output unit power supply circuit and to any connected control devices' power circuit, then connect their contacts to the GLC input unit. Design the circuit so that it checks for an ON signal from the electrical voltage relay using a logic program, then executes the ladder program of the control device connected to the GLC output unit.

■ Input Voltage

The power supply must be within the range of DC24V (DC19.2V to DC28.8V).

■ Power Interruption

If the power supply stops more than 10ms, the GLC's power will be interrupted. Also, when a power interruption occurs, operation will stop even while a command is being issued.

For example, if power is cut while an FMOV command is sending data in 100-word units, execution of the command will stop.

When designing the program, consider the possibility of a power interruption.

■ Emergency Stop Circuit

Do not send an emergency stop signal to the GLC or internally process an emergency stop signal as software.

Create the emergency stop circuit outside the GLC as shown in the figure below.

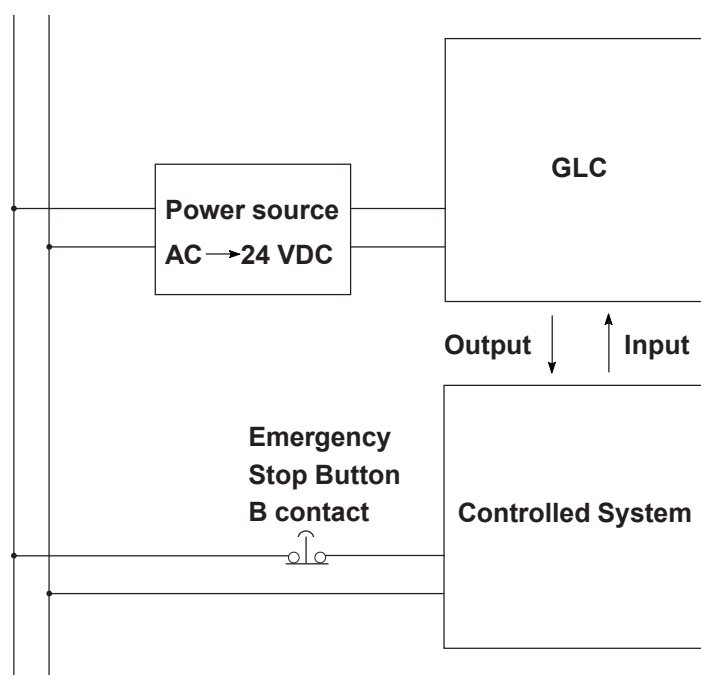

Chapter 3 - Installation and Wiring

■ Interlock Circuit 1

Create an interlock circuit, as shown below, outside the GLC, to control a motor's clockwise/reverse rotation circuit using a GLC or PLC.

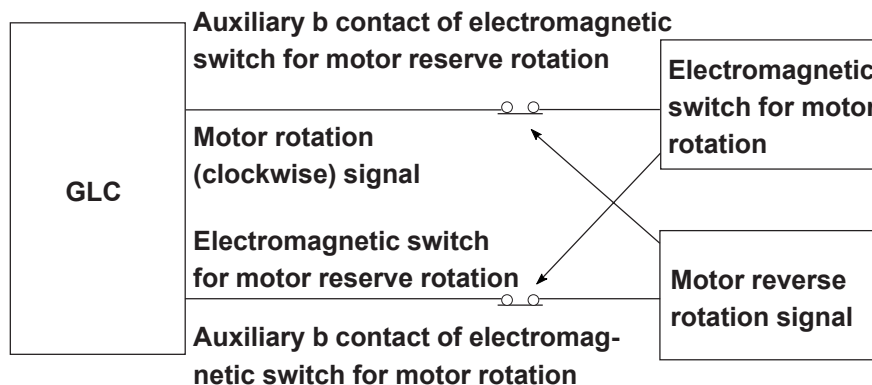

Note: The timing to output ON/OFF information to an output device after program execution is the same for a GLC and PLC. For example, an electromagnetic switch for motor rotation (clockwise) and reverse rotation ON/OFF will be executed at the same time.

Therefore, there are times when the main contact for the power circuits of both the motor rotation (clockwise) electromagnetic switch and reverse rotation electromagnetic switch would turn ON, creating the possibility of an R Phase and T Phase short circuit. Please use the interlock shown above or use a mechanical interlock equipped with an electromagnetic switch for a clockwise/reverse circuit.

■ Interlock Circuit 2

If there is a possibility that a GLC failure could cause an accident, include a fail-safe element in the design of the interlock circuit with an external hardware device.

If the system needs to first stop the Travel Motor whenever the Unit Travel Limit Switch activated, put the Unit Travel Limit Switch in the GLC input. Avoid a design that software processes it.

The example circuit shown below use a hardware method to ensure that Travel Motor is stopped.

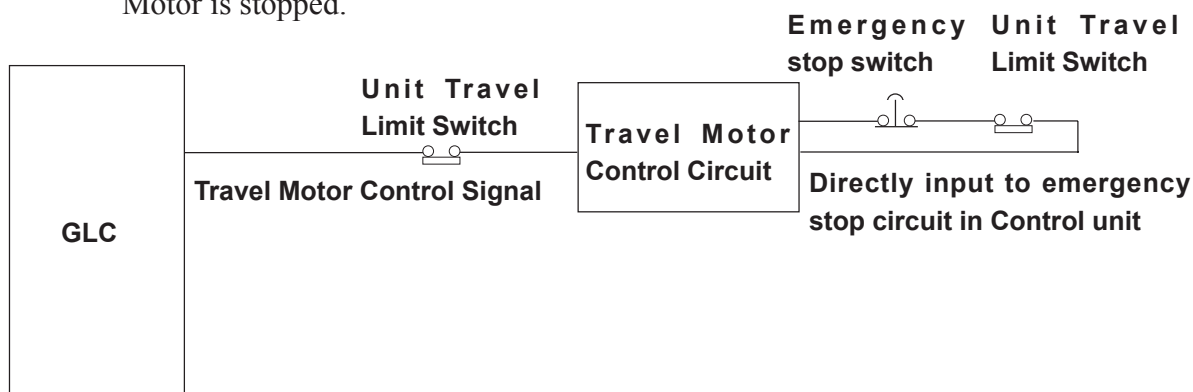

3.3 Tool Connector

The GLC's Data Transfer Cable, Memory Loader, or the Bar Code Reader can be attached to the GLC unit's Tool Connector.



WARNING

To prevent an electric shock, unplug the GLC unit's power cord from the main power supply prior to attaching or detaching any connector(s) to or from the GLC.

Rear Face
GLC-2400T

Tool Connector

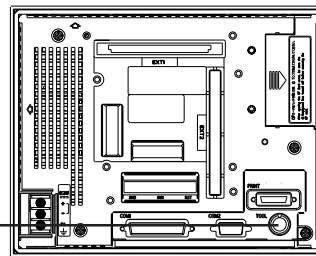

When the Bar Code Reader uses a separate power supply:

- Turn the Bar Code Reader ON before turning the GLC ON.
- Turn the GLC OFF before turning the Bar Code Reader OFF.

3.4 Ethernet Cable Connector

Use the following drawing to locate your GLC unit's Ethernet connector. The GLC Ethernet interface is IEEE802.3 compliant, and transmits data at 10Mbps.

Side Face
GLC-2400T

Ethernet Interface
(RJ-45 Connector)

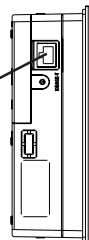

It is strongly recommended that your Ethernet network is installed by a trained engineer.

3.5 CF Card Installation and Removal



CAUTIONS

When using the GLC Unit and a CF Card, follow the precautions below:

- Prior to inserting or removing a CF Card, be sure to turn the GLC unit's CF Card ACCESS switch OFF and to confirm that the ACCESS lamp is not lit. If you do not, CF Card internal data may be damaged or lost.
- While a CF Card is being accessed, NEVER turn OFF or reset the GLC, or insert or remove the CF Card. Prior to performing these operations, create and use a special GLC application screen that will prevent access to the CF Card.

Reference Refer to *GP-PRO/PB III for Windows Tag Reference Manual* (included with the screen editor software package)

- Prior to inserting a CF Card, familiarize yourself with the CF Card's front and rear face orientation, as well as the CF Card connector's position. If the CF Card is not correctly positioned when it is inserted into the Mulit Unit, the CF Card's internal data and the GLC unit may be damaged or broken.
- Be sure to use only CF Cards manufactured by the Digital Electronics Corporation. GLC unit performance cannot be guaranteed when using another manufacturer's CF Card.
- Once GLC data is lost, it cannot be recovered. Since accidental data loss can occur at any time, be sure to back up all GLC screen and CF Card data regularly.

■ Inserting the CF Card

Use the following steps to insert the CF Card in the GLC.

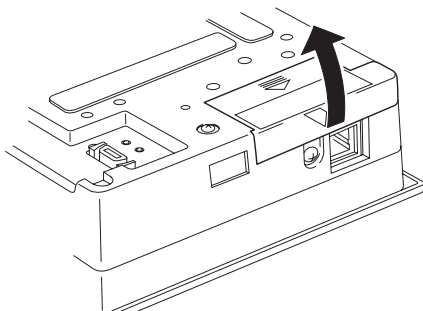

- 1) Slide the CF Card Cover in the direction shown here, then upwards to open the cover.

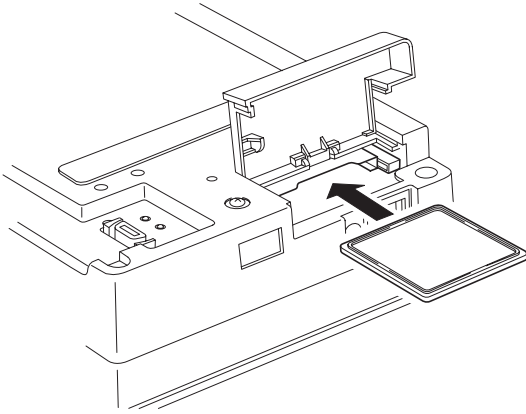

- 2) Insert the CF Card in the CF Card Slot, until the ejector button is pushed forward.

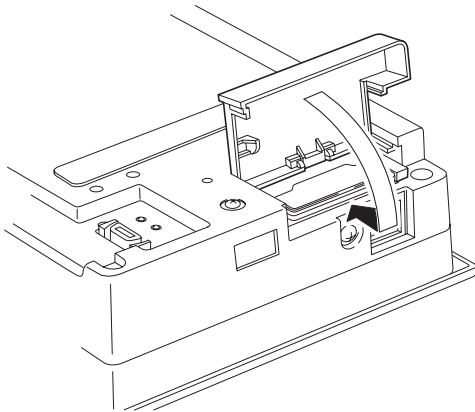

- 3) Close the cover. (As shown.)

- 4) Confirm that the CF Card Access LED turns ON.

■ Removing the CF Card

Simply reverse the steps shown in the previous “Inserting CF Card” explanation. Prior to removing the CF Card, confirm that the CF Card Access LED is turned OFF.

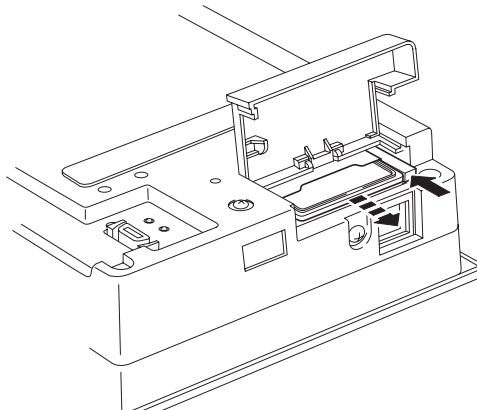

Do not pull out or eject the CF Card when the CF Card access LED is on. Doing so may break or damage the CF Card.

3.6 Connecting to Screw Lock Terminal

External Reset, Flex Network, Sound Output can be connected to Screw Lock Terminal. Follow the following procedure and connect Screw Lock Terminal.

3.6.1 Cable Preparation

Remove the wire's external covering and insert the wire center strand into the connector opening.

Unit: mm[in.]

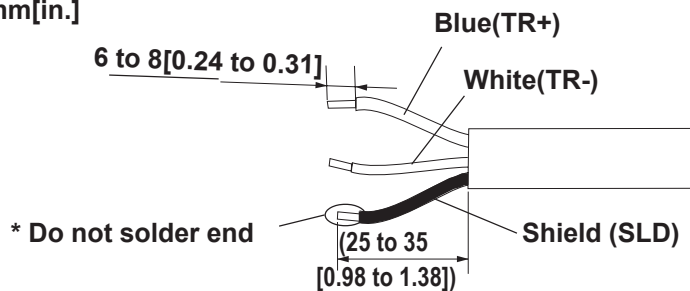

- **Be sure to tape or put a plastic tube over the shield line.**
- **Do not solder the wire itself. This could lead to a bad or poor contact.**

3.6.2 Terminal Connection

Use the following steps to connect the speaker.

- 1) Rotate the screw lock terminal block's two (2) levers in the direction shown (downward), and remove the screw lock terminal block.

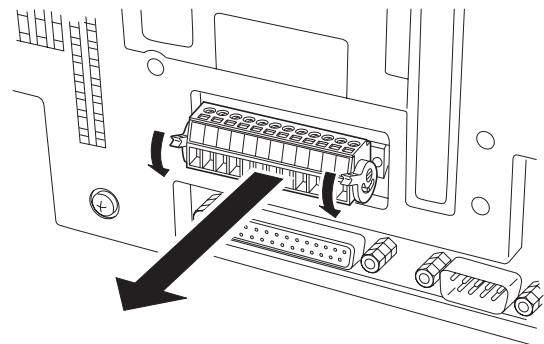

- 2) Loosen the corresponding pin's screw and insert the cable.

For Sound Output, use Pins 10 and 11

Pin number	Signal Name
10	SP OUT
11	GND

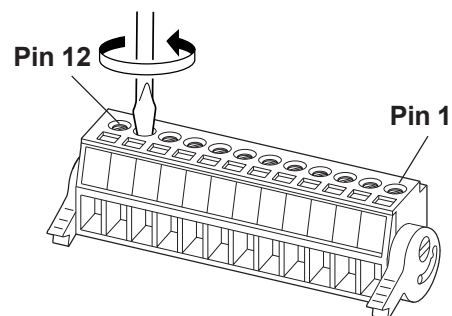

The following pictures show the connection of the Sound Output terminals.

Chapter 3 - Installation and Wiring

- 3) Confirm that each line (cable) is inserted completely, and retighten the two (2) set screws.

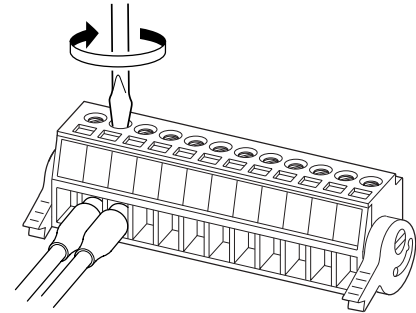
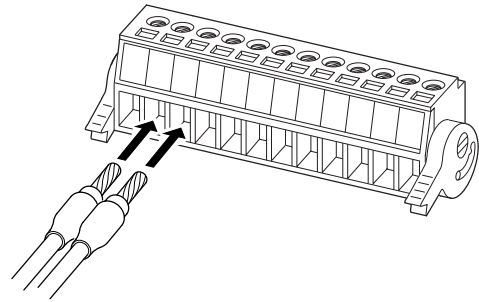

For External Reset, use Pins 1 and 2

Pin number	Signal Name
1	AUXCOM
2	AUXRESET

For Flex Network, use Pins 3 to 8

Pin number	Signal Name
3	TR+
4	TR-
5	SLD
6	TR+
7	TR-
8	SLD

- 4) Reattach the screw lock terminal block to the GLC.

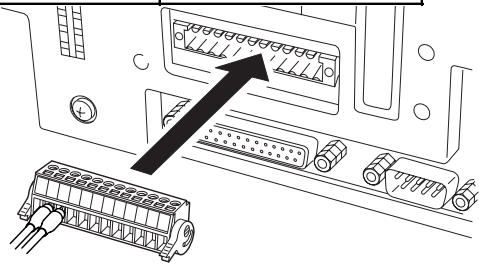

Important

Secure the screw lock terminal wires in place near the GLC via a cable clamp. Be sure not to use too much force and overtighten the wire set screws.



- Note:**
- Use a small-sized screwdriver to tighten the set screws (thickness 0.4 mm, tip width 2.5 mm).
 - The recommended tightening torque for the set screws is 0.2 to 0.4 N•m.
 - If wire ends are not carefully twisted, strands from adjacent wires or contact with an electrode may cause a short circuit.

The following Pin Jack Terminal is recommended:



- Phoenix Contact AIO.5-6WH, AIO3-6TQ

Chapter 3 - Installation and Wiring



3.6.3 Sound Volume Adjustment

1) Call up the GLC menu bar.

▼Reference▲ 6.4.3 SETUP TOUCH PANEL

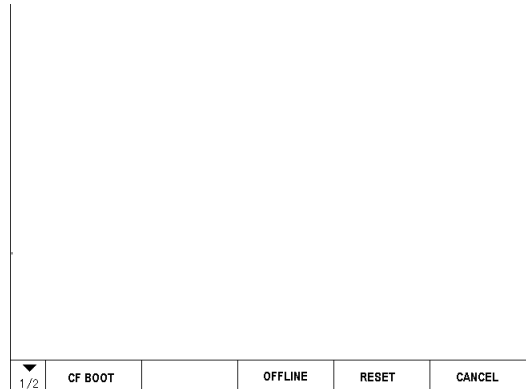
2) Touch the left-most   key to call up the next menu.

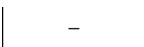

3) Touch the  and  keys to adjust the sound volume to the desired level.

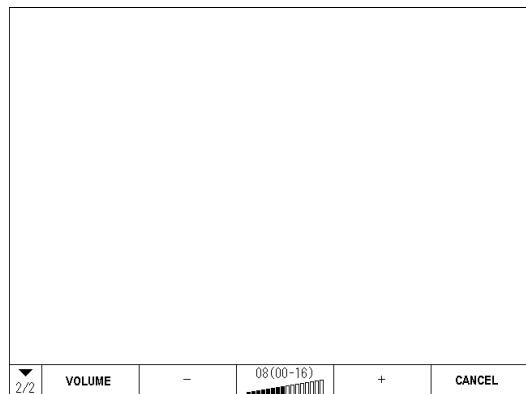

Chapter

4 Data Transfer

1. Serial Data Transfer
2. Ethernet Data Transfer
3. CF Memory Loader Tool

This chapter explains following three (3) methods of transferring data created with the the GLC screen creation software to or from the GLC.

- Transfer data via the data transfer cable to or from your GLC.
- Transfer data via an Ethernet network to the GLC.
- Transfer data via the CF Card to or from your GLC using the CF Memory Loader Tool.

4.1 Serial Data Transfer

The following explains how to connect Pro-face's data transfer cable to your PC and to the GLC.

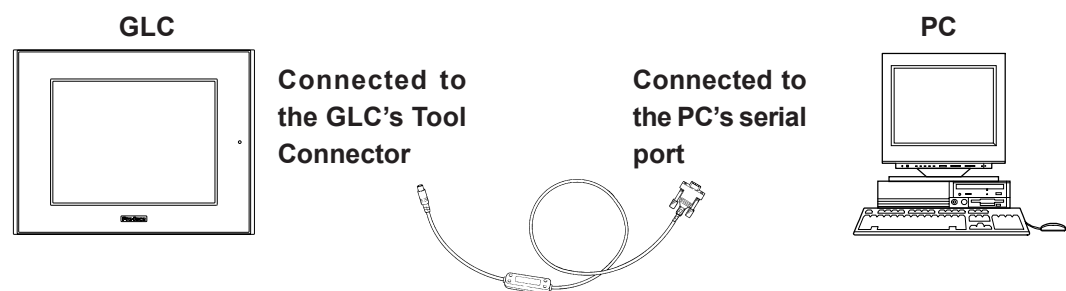

Note:

- Pro-face's transfer cable (GPW-CB02) is sold separately. The transfer cable package does not include the PC's interface converting adapter.
- When using the PC with the Dsub 25pin socket side interface, a connector conversion adapter is required. Use the straight line type conversion adapter.

Recommended units:

Abel Co. AA833

Sanwa Supply Co. D09-9F25F

- When using a PC equipped with a half-pitch 14pin socket interface, a conversion adapter is required.

Recommended unit:

Arroz Co. ZR01-024

Chapter 4 - Transfer Screen Data

Transfer screen data from your PC, via the GP screen creation software.

Reference For details about the GP screen creation software, refer to **GP-PRO/PBIII for Windows Operation Manual** (included with the GP screen creation software)

■ To Transfer Data to a Completely New GLC

Connect the GLC to your PC via the data transfer cable, and then turn the GLC ON. The “Initial Start Mode” screen will appear on the GLC and you can transfer screen from your PC. The screen will change to the “Transfer” screen automatically.

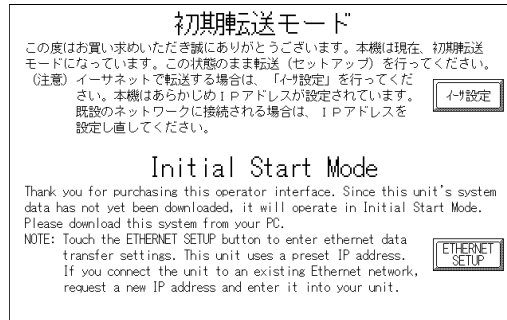

■ After Completing Data Transfer using GLC setup*1

Transfer screen data from the GLC screen creation software, and select the “Transfer” mode.

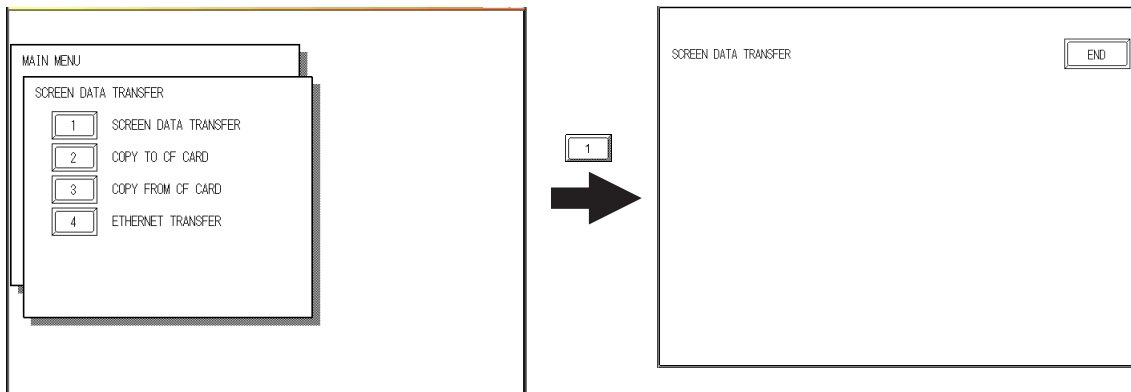

During data transfer, the “SETUP Transfer” and “Now Transferring - Please Wait” messages will appear. When these messages disappear, screen data transfer is completed.

If you wish to stop data transfer, simply cancel it from your PC’s GLC screen creation software.

*1 “Set up the GLC” means configuring the GLC operating condition by downloading the system program and the protocol program etc. from the GLC screen creation software to the GLC.

Chapter 4 - Transfer Screen Data

If you try to set up the GLC after data transfer, the OFFLINE mode's "Main Menu" will appear. If you do NOT set up the GLC, the screen designated in "INITIAL SETTINGS/SCREEN SETUP/INITIAL SCREEN FILE NO. " will appear and the screen will change to operation (RUN) mode.

Logic Program Data Transfer is only available with the GLC, which is pre-installed.

Reference *Pro-Control Editor Operation Manual (included in the GLC screen creation software package)*



Do NOT disconnect the GLC's power supply, turn OFF the PC, or disconnect the GLC's transfer cable during the data transfer. If you do, an error may occur when the GLC is started.



If the GLC screen creation software's "GLC SYSTEM SETTINGS"*¹ data is transferred to the GLC, the OFFLINE mode "INITIAL SETTINGS" data will be overwritten.

*1 Some GLC Offline displays are referred to as "GP", however it is the same as "GLC" here.

4.2 Ethernet Data Transfer

The GLC2400 is equipped with the Ethernet I/F which allows you to set up the GLC via an Ethernet network, as well as transfer GLC screen data.



When using the Ethernet communication protocol, you must specify the port number for the protocol as +10 or higher than the value specified in this section. Otherwise, the setup or screen data transfer via Ethernet is disabled.

After you connect an Ethernet cable to the GLC's Ethernet I/F, the GLC will appear on the Ethernet network.

■ Transferring Data to a Completely New GLC

◆ Setting Up the IP Address Manually

Touch the “Ethernet Settings” button on the GLC2400 Initial Start Mode screen.

▼ Reference ▲ 6.5.4 ETHERNET SETUP

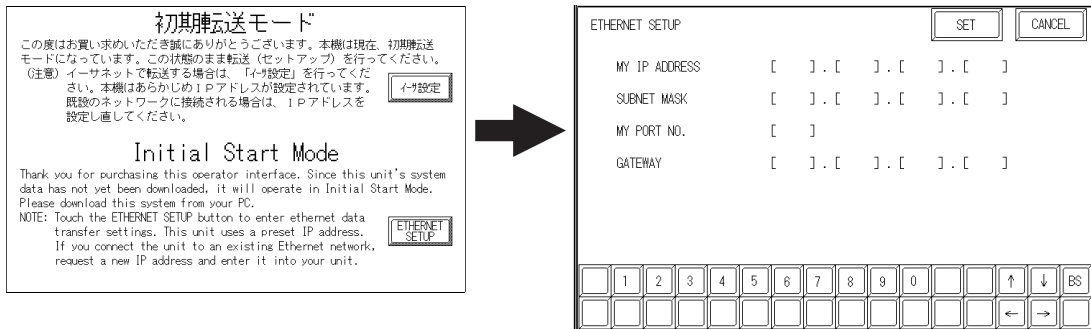

◆ Setting Up the IP Address Automatically

It is not necessary to select “Ethernet Settings” on the GLC2400 Initial Start Mode screen. When the options for “Ethernet Settings” are not specified, they are set automatically.

If you choose to set the IP address automatically, specify the IP address of the PC in the range of “10.255.255.1” to “10.255.255.254” and the subnet mask as “255.0.0.0”.

Transfer data using the GLC screen creation software package.

▼ Reference ▲ “GP-PRO/PBIII for Windows Operation Manual” (included with the GLC screen creation software package)

■ When transferring data using the GLC setup*¹ is completed

When you transfer screen creation software data from your PC to the GLC while the GLC is in RUN mode, the screen will change automatically to “Ethernet Mode”. If it does not, you will need to manually change the GLC screen to Ethernet Mode, via the following screen.

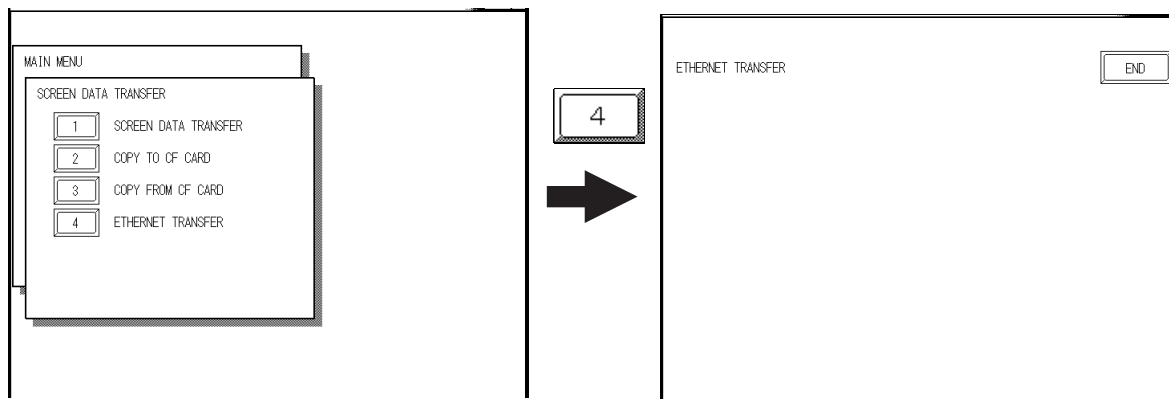

You can now transfer data from your PC’s screen creation software.

Reference *GP-PRO/PBIII for Windows GLC2400 Update Operation Manual (included in the GLC screen creation software package)*

Execute the logic program data transfer from the Logic Program Development Software. For Operation of Logic Program Development Software, **Reference** *GP-PRO/PBIII for Windows GLC2400 Update Operation Manual (included in the Pro-Control Editor)*

Chapter 4 - Transfer Screen Data

4.2.1 Checking the IP Address

Use the following procedure to check the IP Address assigned to the GLC and some consideration/precautions.

- 1) Display the menu bar. For instructions on how to display the menu bar, **Reference** [6.4.3 Touch Panel Setting](#)
- 2) Click on the left-side 1/3 cell of the menu bar to display the next menu.

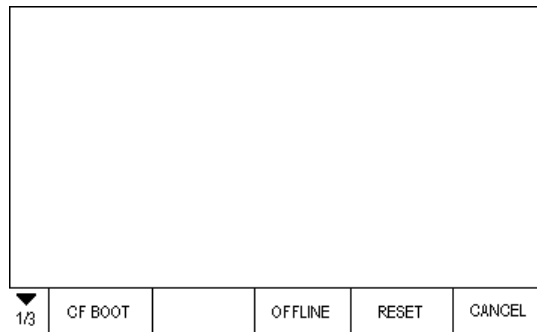

- 3) Next, click on the 2/3 cell to display the following menu.

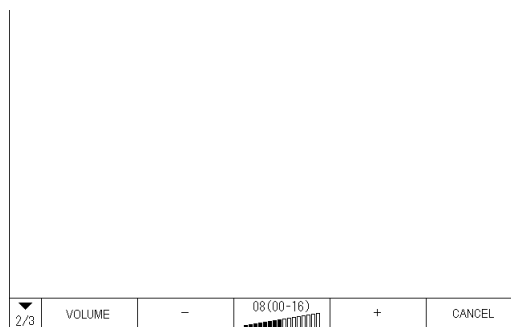

- 4) The IP Address assigned to the GLC will appear in the menu bar.

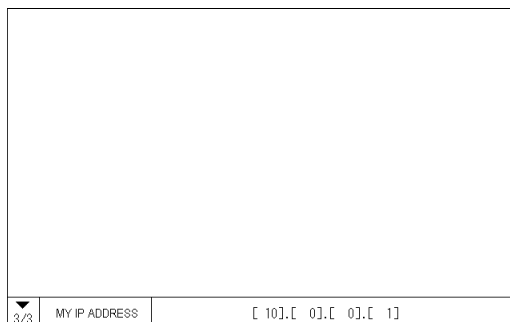

Note: IP Address will not be reflected unless GLC was reset or power cord was re-connected. After changing “Ethernet Setup” settings, the GLC must then be reset or power cord must be re-connected.

4.3 CF Memory Loader Tool

The GLC2400 allows you to use the CF Memory Loader Tool in the CF Card to set up the GLC, transfer screen data, and upload GLC internal data to its internal CF Card.



Note: • You need to transfer the CF Memory Loader Tool to the CF Card prior to using the CF Memory Loader Tool.

▼ **Reference** ▲ GP-PRO/PBIII for Windows Operation Manual

• The CF Memory Loader Tool and Backup Data require at least 8MB of CF Card memory. Use Digital's CF Card "GP077-CF20 (16MB)".

■ Starting the CF Memory Loader Tool

There are two methods for starting this program via the CF Card.

1. Menu Bar: Using the GLC's [CF BOOT] menu

Insert the CF Card with the CF Memory Loader Tool saved into the GLC and touch the menu screen's [CF BOOT] selection. The GLC will be reset, and after it restarts, the CF card's "CF Memory Loader Tool" will start.

▼ **Reference** ▲ For how to display the Menu bar, refer to 6.4.3 ETHERNET SETUP

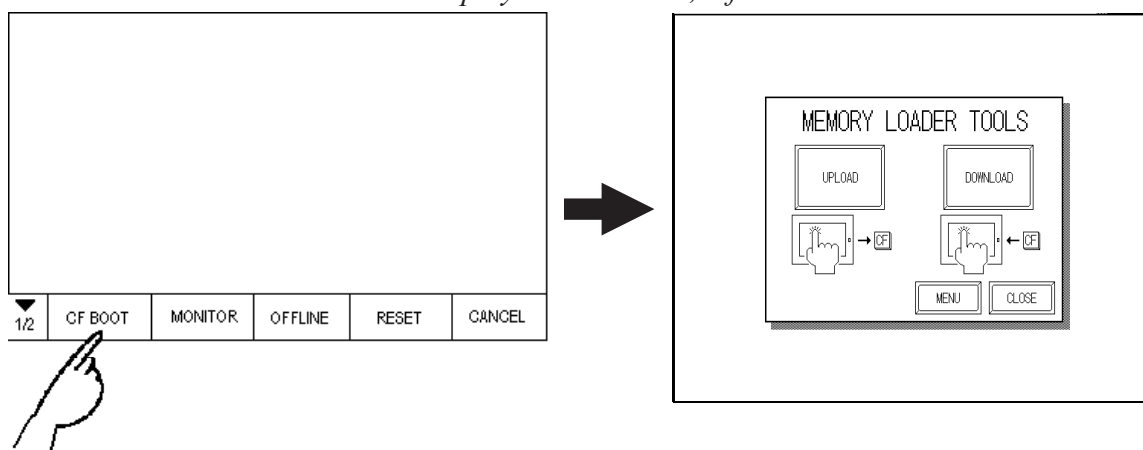

2. GLC Dip Switches: Forced Start via GLC Dip Switches

You can also use the Dip Switches on the rear of the GLC, next to the CF Card Slot. If you turn ON Dip Switch No.1 (raise it) and then connect the GLC unit's power cord, the "CF Memory Loader Tool" will automatically start.

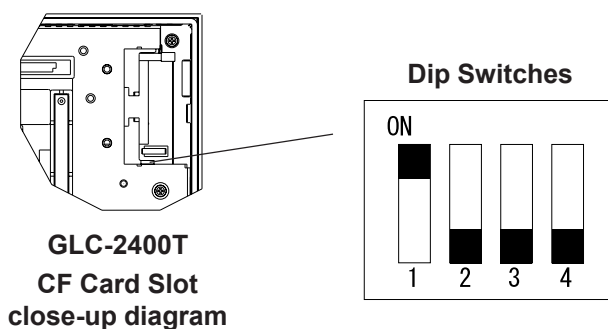

Note: When you finish using the CF Memory Loader Tool, turn OFF this dip switch.

Chapter 4 - Transfer Screen Data

4.3.1 Data Upload and Download

When the Memory Loader Tool program starts, the following screen will appear.

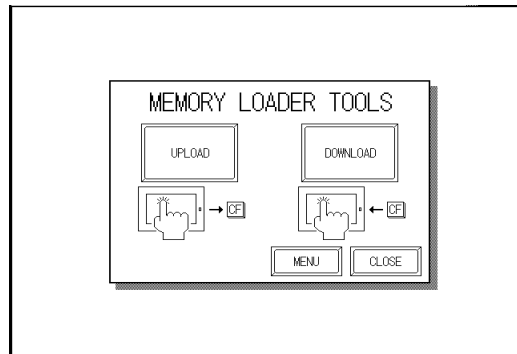

■ UPLOAD (From GLC to CF Card)

This feature is for saving all GLC internal data (i.e. system program, communication protocol, expansion program, screen data and Backup SRAM data) in the CF Card as backup data.

To start data upload, enter the password you designated in the GLC screen creation software's "Transfer" screen, and then touch the "START" key. If you have not designated a password however, simply touch the "START" key.



When *UPLOAD* is performed, the CF Card's current Backup Data will be completely overwritten.

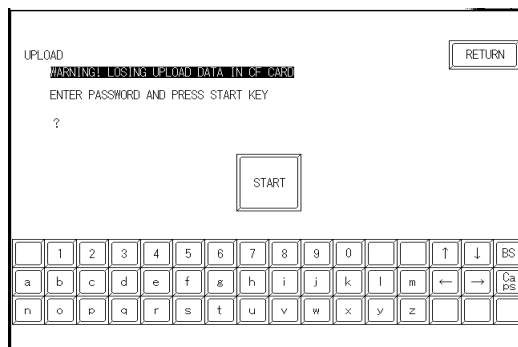

■ DOWNLOAD (From CF Card to GLC)

This feature is used for writing CF Card backup data to the GLC's Internal SRAM Memory.

To start data download, enter the password you designated in the GLC screen creation software's "Transfer" screen, and touch the "START" key. If you have not designated a password, simply touch the "START" key.



When *DOWNLOAD* is performed, the GLC's Internal Memory data (i.e. system program, communication protocol, expansion program, screen data and Backup SRAM data) will be completely overwritten.

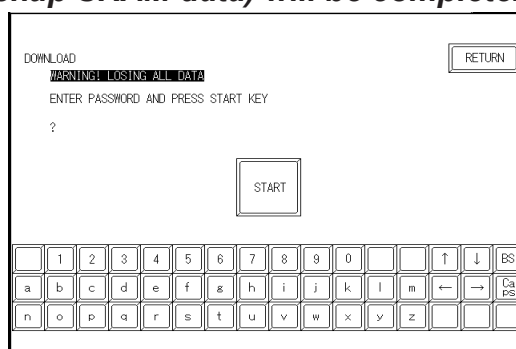

Chapter

5 OFFLINE Mode

1. Entering OFFLINE Mode
2. OFFLINE Mode Main Menu
3. INITIALIZATION
4. SELF-DIAGNOSIS

OFFLINE Mode provides access to the Initialize, Self-Diagnosis, and other features built into the GLC. Before you can use any of these features, however, you will need to change the GLC to OFFLINE mode.



OFFLINE mode is unavailable in a completely new GLC until the necessary GLC system data has been transferred from your PC's screen editor software. To do this, be sure the GLC's power cord is plugged in and when you transfer screen data from your PC to the GLC, your GLC's system data will be automatically sent.

Reference For information about transferring data to the GLC, refer to Chapter 4-Transfer, or the *GP-PRO/PBIII for Windows Operation Manual* (included with the screen creation software)

5.1 Entering OFFLINE Mode

To INITIALIZE your GLC or perform SELF-DIAGNOSIS, you must first switch the GLC to OFFLINE mode. There are two ways to enter OFFLINE mode. First, is immediately after plugging in the GLC's power cord, and second, by using the Forced Reset feature.

5.1.1 After Plugging in the Power Cord

Touch the upper left-hand corner of the GLC screen within 10 seconds of plugging in the GLC's power cord and the GLC will change to OFFLINE mode.

When changing a Logic Program from RUN to OFFLINE mode, the action performed by the GLC and the I/O signal will be as follows, regardless of the current output hold setting. Please be aware of the effect of changing to OFFLINE mode and/or performing RESET.

	→		
GLC Condition	RUN	OFFLINE	RUN
I/O Signal	ON Output from Logic Program	OFF	ON Output from Logic Program
	OFF		OFF

Chapter 5 - OFFLINE Mode

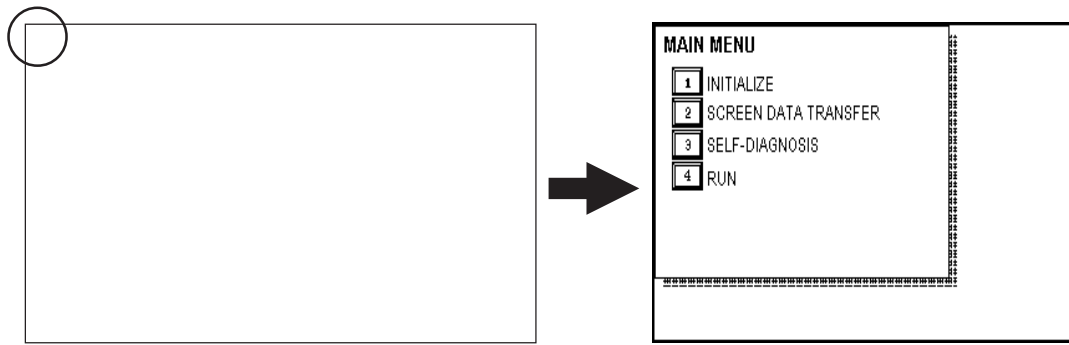

To enter OFFLINE mode, touch the upper-left corner of the screen within 10 seconds of connecting the GLC unit's power cord.

5.1.2 From the Menu Bar

From the GLC unit's Menu Bar, touch the OFFLINE square and the OFFLINE mode Main Menu will appear.

Reference For instructions on how to call up the Menu Bar, refer to 6.4.3 "SET UP TOUCH PANEL; FORCED RESET"

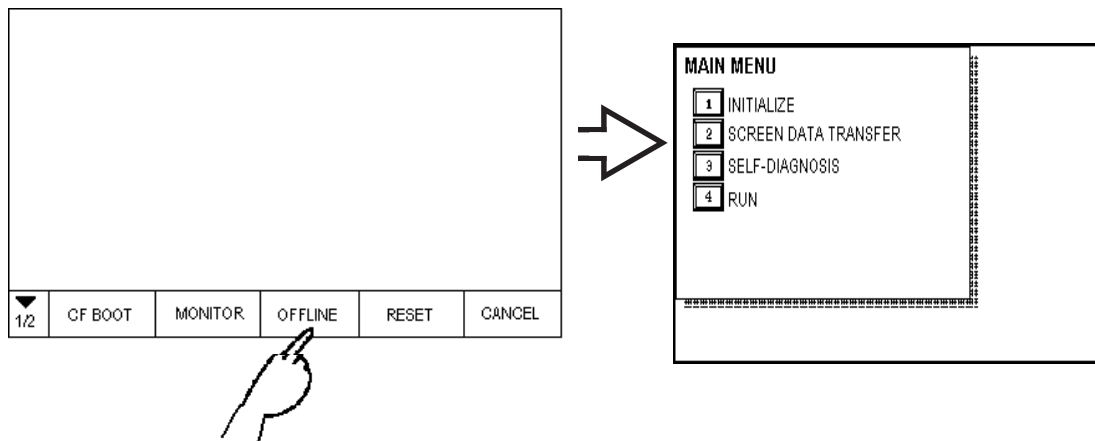

Note: If your GLC unit has the Device Monitor feature, the "Monitor" square will also appear.

Reference *GP-PRO/PBIII for Windows PLC Connection Manual (included with the screen creation software), Appendix 3 - Device Monitor*

If a Password has been entered in the INITIALIZE/ SET UP SYSTEM area, before entering the OFFLINE mode, the following screen appears. Here, enter the password, then touch *Set* to enter OFFLINE mode.

Reference For more information about Passwords, **Chapter 6.3.1, "SYSTEM SETUP"** and **Chapter 5.3, "Initialize-Standard Operation"**

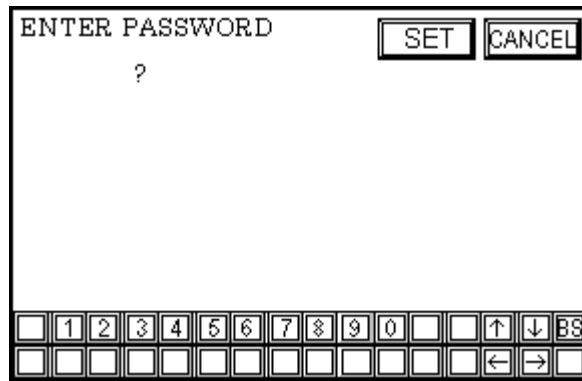

5.2 OFFLINE Mode Main Menu

The Main Menu contains the following four items: “INITIALIZE”, “SCREEN DATA TRANSFER”, “SELF-DIAGNOSIS” and “RUN”.

Each menu item shown below has different settings that must be set to match the corresponding PLC in order for the GLC to communicate properly.

Entering OFFLINE mode calls up the following screen.

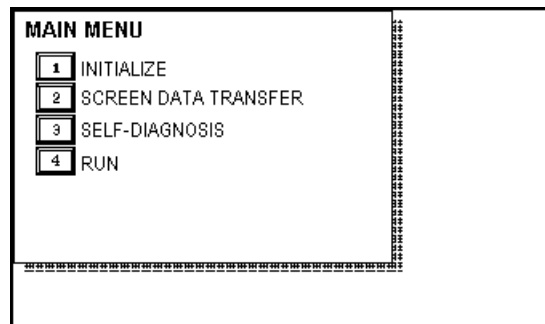

Select the desired menu item by touching the corresponding screen item bar.

Each Main Menu item is used as follows.

INITIALIZE

The setup items contained in this menu are used to control the GLC unit.

SCREEN DATA TRANSFER

Select to transfer screen data to and from the screen editing software.

SELF-DIAGNOSIS

Checks to see if there are any problems with the GLC System or Interface (I/F).

RUN

Starts GLC operation.

▼ Reference ▲

*For more information about INITIALIZE, refer to **Chapter 6***

*For more information about TRANSFER SCREEN DATA, refer to **Chapter 4** or **GP-PRO/PBIII for Windows Operation Manual** (included with the screen creation software)*

*For more information about SELF-DIAGNOSIS and RUN, refer to **Chapter 7**.*

5.3 INITIALIZATION

■ Selecting A Menu

Touch the menu number to select it.

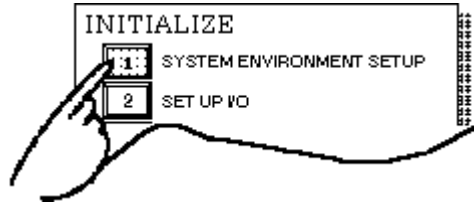

Touch the menu to select it.

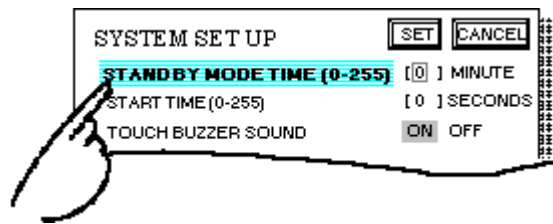

■ Entering Numbers

Touching a menu item or an enter field enables you to enter the numeric values. Use the numeric touch keys located at the bottom of the screen to enter numeric values.

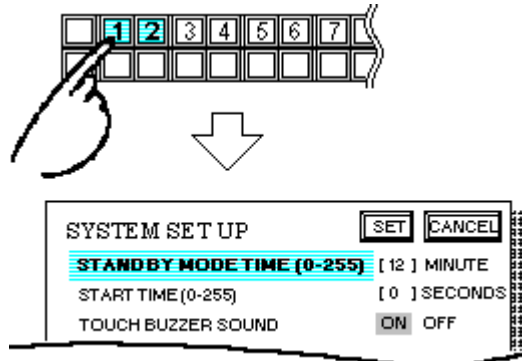

■ Selecting Setup Conditions

After selecting a menu item and entering that area, touch the option you would like to setup. The selected item becomes highlighted. In this example, the TOUCH BUZZER SOUND has been set to OFF.

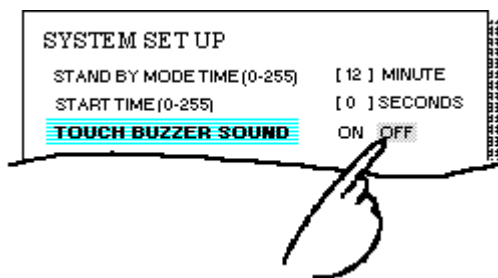

■ After All Setting Data is Entered

Touch the top-left [SET] key.

If you wish to exit the screen without saving the changes, touch the [CANCEL] key.

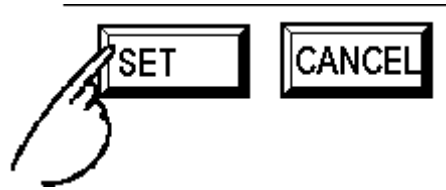

- Press the [SET] key to write the Setup conditions to the Internal FEEPROM, which will require a short period of time. Until this processing is completed, do not touch the screen until the previous menu reappears.
- Press the [CANCEL] key to return to the previous menu, without writing the Setup conditions to the Internal FEEPROM.

■ Return To Previous Screen

Touch the title of the screen you would like to return to.

E.g. To return to the MAIN MENU from the SYS.ENVIRONMENT screen, simply touch the MAIN MENU title.

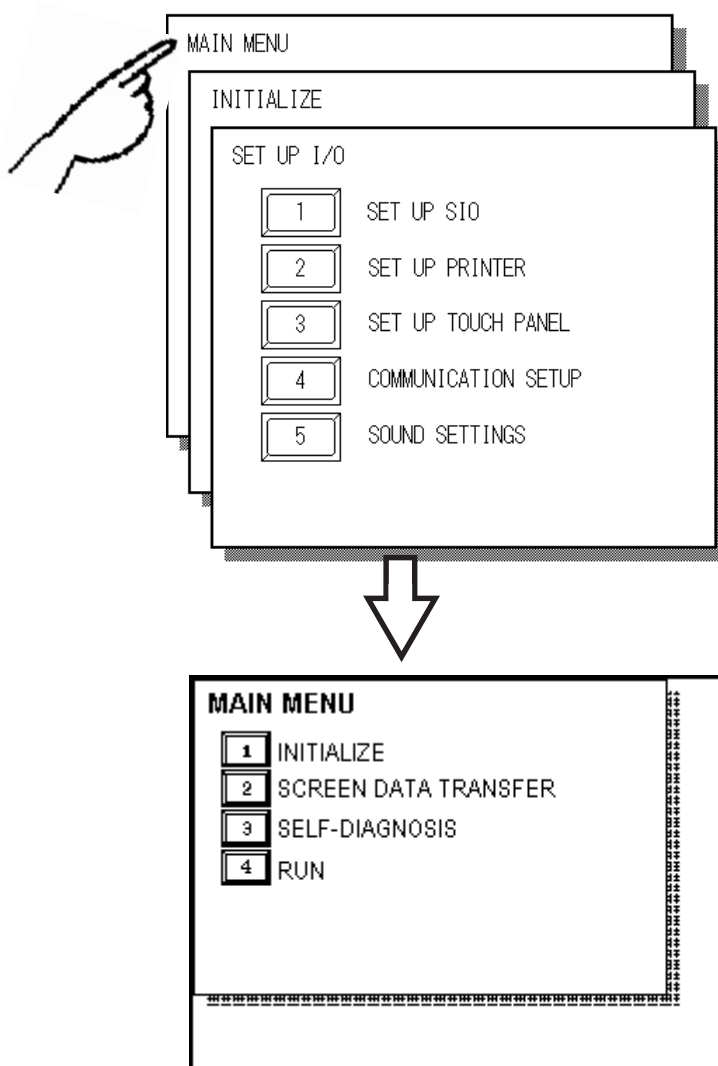

5.4 SELF-DIAGNOSIS

■ Selecting a Sub-Display

Touch the desired the menu item and that sub-display will appear.

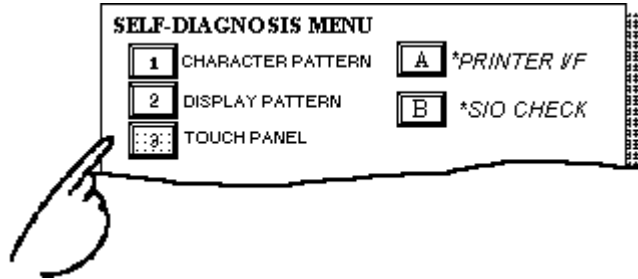

■ [CONFIRM], [START] and [CANCEL] Keys

After selecting the Self Diagnosis item, the [CONFIRM], [START], and [CANCEL] keys may appear at different times at the top of the screen.

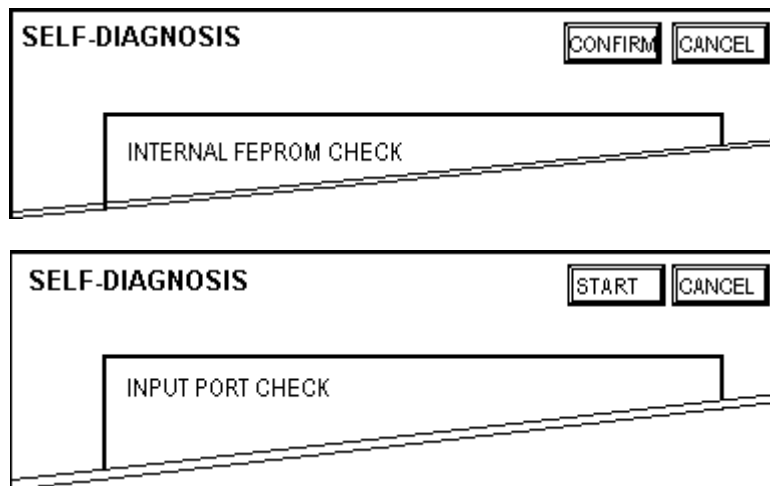

[CONFIRM] Key

Touching this key informs the GLC that you have completed all the necessary steps prior to running "Self Diagnosis". All these steps will be shown in the GLC's message dialogs.

[START] Key

Touch this key to start the checking process.

[CANCEL] Key

Press this key to cancel the Self-Diagnosis test. Control will then return to the SELF-DIAGNOSIS menu.

■ After Check - To Return To SELF-DIAGNOSIS MENU

When OK displays,

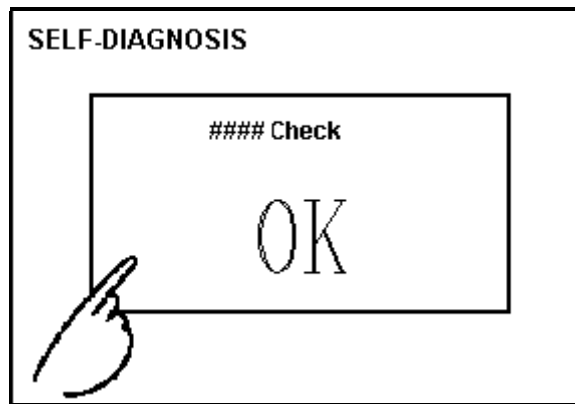

Pressing once anywhere on the display screen returns you to the SELF-DIAGNOSIS MENU.

■ When an Error Message displays

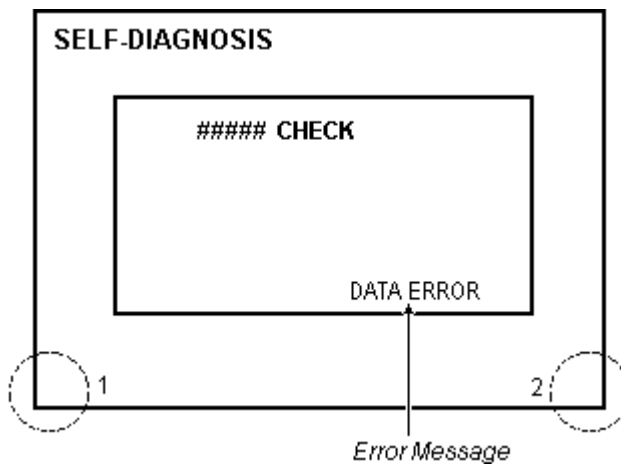

Touch the bottom two corners of the panel (1, 2) to return to the SELF-DIAGNOSIS MENU.

■ Return To Main Menu

Touch the "RETURN" key to return to the main menu screen.

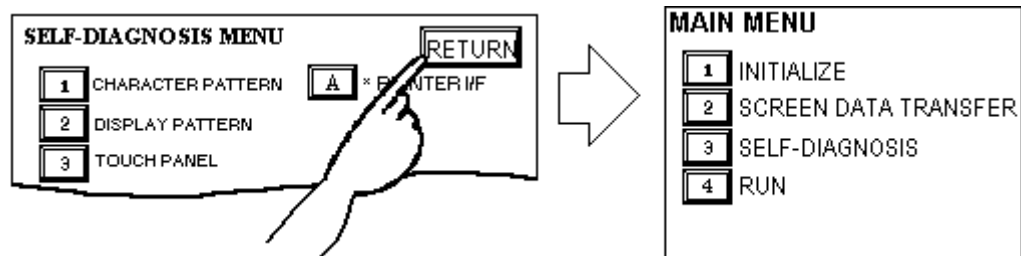

Memo

Chapter

6 Initializing the GLC

1. Initialization Screen
2. Initialization Items
3. SYSTEM ENVIRONMENT SETUP
4. SET UP I/O
5. PLC SETUP
6. INITIALIZE INTERNAL MEMORY
7. SET UP TIME
8. SET UP SCREEN

6.1 Initialization Screen

Occasionally, you may want to change your GLC's general operation settings. The settings used for this are found in the INITIALIZE option in the GLC OFFLINE mode's MAIN MENU.

This chapter explains each of the OFFLINE mode's INITIALIZE items. However, there are 2 types of INITIALIZE settings, those for the **1:1** connection and those for the **n:1** (multi-link) connection*¹.

The **n:1** mark appears on original menu items related to n:1 multi-link connection items. If there is no mark, the menu item is common to both 1:1 and n:1 connections.

1:1 A single (1) GLC is connected with a single (1) PLC.

n:1 Multiple GLCs are connected with a single PLC. The GLCs successively pass a *PLC Access Token* (exclusive PLC interaction key) among themselves to designate which unit can communicate with the PLC.



- If you transfer the GLC's system file data to the GLC via your screen design software*², the GLC operates using that data. If the GLC System file has been correctly setup and transferred, the setting of INITIALIZE items become unnecessary.

Reference *For more information about GLC System files*

Operation Manual, 1.1.2 "Screen Types" (included with screen creation software)

- Some GLC Offline displays are referred to as "GP", however it is the same as "GLC" here.

*¹ PLC's that support the n:1 (multi-link) connection are limited.

Reference *PLC Connection Manual (included with the screen creation software)*

*² Refer to GLC screen creation software's "SYSTEM SETTINGS" area.

6.2 Initialization Items

This chapter explains the contents of the Initialize setup items listed below. For information about screen operations and numeric input.

Reference Chapter 5, "OFFLINE Mode"

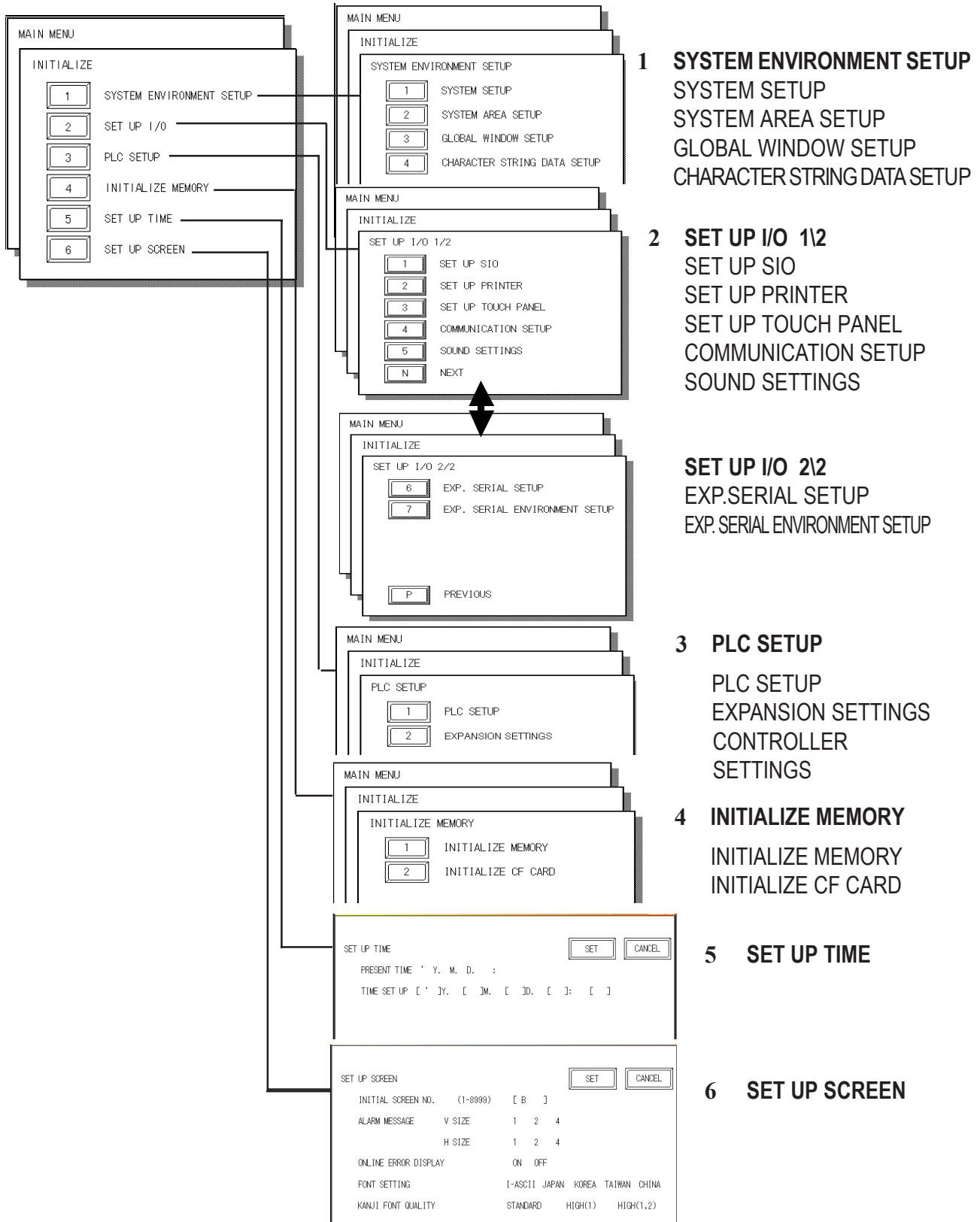

*1 Note that, depending on the PLC type selected, the screens that appear in your GLC's screen editor software will vary.

6.3 SYSTEM ENVIRONMENT SETUP

These settings allow you to adjust the GLC's operation environment. SYSTEM ENVIRONMENT SETUP includes the SYSTEM SETUP, SYSTEM DATA AREA, GLOBAL WINDOW SETUP, and CHARACTER STRING DATA SETUP screens.

6.3.1 SYSTEM SETUP

SYSTEM SETUP		SET	CANCEL
STAND BY MODE TIME (0-255)	[]	MINUTE	
START TIME (0-255)	[]	SECOND	
TOUCH BUZZER SOUND	ON	OFF	
BUZZER TERMINAL OUTPUT	ON	OFF	
PASSWORD (0-9999)	[]		
DATA TYPE OF SCREEN NO.	BIN	BCD	

STAND-BY MODE TIME (0-255)

To extend the life of the GLC's backlight, the GLC is equipped with a screen saver function that automatically turns the unit's backlight(s) OFF when no operations have occurred for a designated period of time. A "0" entered in this field causes a normal display, i.e. the screen is cleared after the GLC's standard default time elapses.

When SYSTEM DATA AREA's (**Reference** *GP-PRO/PBIII for Windows PLC Connection Manual* - included with the screen creation software) SCREEN DISPLAY OFF*1 data is 0000h, and the following operations are *not* performed on the screen for the User's designated period of time, the GLC's current display is turned OFF.

- Change Screen
- Touch Screen
- Alarm Display

START TIME (0-255)

This setup determines the start-up time of the GLC. Use this setup to adjust the power up sequence so that the GLC starts up after the PLC.

TOUCH BUZZER SOUND

Setup whether or not the GLC beeps when pressed.

BUZZER TERMINAL OUTPUT

The GLC2400 does not have this feature, therefore this setting will be disabled.

*1 When using the Direct Access or the Memory Link formats, the object address becomes +9 or +12, respectively. (Only when all items are set within the System Data Area.)
Reference *GP-PRO/PBIII for Windows PLC Connection Manual* (included with the screen creation software)

Chapter 6 - Initializing the GLC

PASSWORD SETUP(0-9999)

The password setting is used when changing to the Initialize Memory or Initialize (OFFLINE mode) Screens. The password (*from 0 to 9999*) ensures protection of the GP settings, since the use of OFFLINE mode is controlled. If you do not wish to use this feature, enter the default value, 0.

DATA TYPE OF SCREEN NO.

This setup controls whether BIN or BCD format numbers are used when making screen changes. Screen numbers 1 to 8999 are available for binary format; screen numbers 1 to 1999 are available for BCD format.

6.3.2 SYSTEM AREA SETUP

The System Data Area is used by the PLC to control its GLC-related data, and is contained in the PLC. The types of devices that can be set up in the System Data Area differ depending the PLC type.

When the GLC uses Memory Link format, this setting is unnecessary.

Reference *PLC Connection Manual* (included with the screen creation software)

Simply touch the number for the item desired. The item will change to reverse video, to show it has been selected.

SYSTEM AREA SETUP		CONFIRM CANCEL	
1	CURRENT SCREEN NO. (1 WORD)	8	CLOCK DATA (SET) (4 WORDS)
2	ERROR STATUS (1 WORD)	9	CONTROL (1 WORD)
3	CLOCK DATA (CURRENT) (4 WORDS)	A	RESERVED (1 WORD)
4	STATUS (1 WORD)	B	WINDOW CONTROL (1 WORD)
5	RESERVED (1 WORD)	C	WINDOW REG. NO. (1 WORD)
6	CHANGE SCREEN NO. (1 WORD)	D	WINDOW LOCATION (2 WORDS)
7	DISPLAY ON/OFF (1 WORD)	SYSTEM AREA SIZE: WORD(S)	

(Item numbers displayed in reverse mode are selected.)

System Area Size

◆ System Area Size

This field displays the total number of words used for the items selected from the SYSTEM AREA SETUP (**Write:** from 1 to 5 and **Read:** from 6 to D).

When you press the Confirm key, the SYSTEM AREA CONTENTS screen appears to confirm the selected items



Note:

- These settings are enabled only when using Direct Access format.
- The selected System Area items, as displayed on the screen, become the System Data Area.

Chapter 6 - Initializing the GLC

When these five items, "Current Screen Number", "Error Status", "Clock Data (Current)", "Change Screen Number", and "Display ON/Off", have been selected, word addresses are assigned to each item, in order, as shown here.

SYSTEM AREA CONTENTS	WORD	BYTE	SET	CANCEL
	+0	+0, 1		
	+1	+2, 3		
	+2	+4, 5		
	+3	+6, 7		
	+4	+8, 9		
	+5	+10, 11		
	+6	+12, 13		
	+7	+14, 15		
	+8	+16, 17		
	+9	+18, 19		
	+10	+20, 21		
	+11	+22, 23		
	+12	+24, 25		
	+13	+26, 27		
	+14	+28, 29		
	+15	+30, 31		
	+16	+32, 33		
	+17	+34, 35		
	+18	+36, 37		
	+19	+38, 39		

In the screen above, the device address used for [SET UP OPERATION SURROUNDINGS]'s "SYSTEM AREA START DEV / START ADR" is "+0".

Thus, in the example shown above, when the "SYSTEM AREA START DEV / START ADR" is "D00200", and the [CHANGE SCREEN NO.] has been designated, the address is shown as "+6" and you will need to then enter "D00206" (i.e. "D00200" + 6) to use this address.

For details about setting "SYSTEM AREA START DEV / START ADR", refer to

Reference 6.5.1 SET UP OPERATION SURROUNDINGS(1:1/n:1)

Chapter 6 - Initializing the GLC

6.3.3 GLOBAL WINDOW SETUP

A GLC2400 Series unit can display one *Global Window* and two *Local Windows* at any one time. The Global Window is common to all the display screens. The Local Window displays exclusively on a designated base screen. The GLOBAL WINDOW SETUP is described here.

GLOBAL WINDOW SETUP		SET	CANCEL
GLOBAL WINDOW	USE	DO NOT USE	
GLOBAL WINDOW ACCESS	DIRECT	INDIRECT	
DATA FORMAT	BIN	BCD	
REGISTRATION NO. (1-256)	[]	ⓂIRECT MODE ONLY	
WINDOW LOCATION	X POSITION (0-) []	ⓂIRECT MODE ONLY	
	Y POSITION (0-) []	ⓂIRECT MODE ONLY	

The items in this area are only valid when using the Global Window.

GLOBAL WINDOW

Two options are available: **Use** and **Do Not Use**. If you select **Do Not Use**, ignore the items described below. Selecting **Use** enables the following options.

GLOBAL WINDOW ACCESS

Use this feature to designate whether values used by the GLC are DIRECT or INDIRECT, i.e. the REGISTRATION NO. and the LOCATION values. When set as Direct, the REGISTRATION NO. and LOCATION selections are fixed to the values entered here. When set to Indirect, the WINDOW REG. NO.'s word address is used by the SYSTEM AREA as a variable. This means the REGISTRATION NO. written to it changes and, as a result, can call up multiple window screens as Global windows. You can also use this method to adjust the Global window's position by writing the desired X,Y coordinates to the SYSTEM AREA's LOCATION word addresses.

DATA FORMAT

Setup whether the REGISTRATION NO. and the LOCATION values are BIN or BCD values. This field is related only to indirect values.

REGISTRATION NO.

Enter the Window Screen Number used by the Global Window. This field is enabled only when GLOBAL WINDOW ACCESS is set to direct.

WINDOW LOCATION

Enter the value used for the (Global WINDOW) LOCATION. This field is enabled only when GLOBAL WINDOW ACCESS is set to direct. Use this setting to designate the top left coordinate on the screen registered as a Global Window. If you are installing the GLC vertically, i.e. in portrait not landscape mode, designate the bottom left coordinate instead

6.3.4 CHARACTER STRING DATA SETUP

Character String Data ordering varies from manufacturer to manufacturer. Setup the Character String Data order here to match the corresponding PLC.

CHARACTER STRING DATA SETUP

CHARACTER STRING DATA MODE (1-8) []



Setup the CHARACTER STRING DATA MODE to match the PLC type. Device type and Tag settings are unavailable.

■ CHARACTER STRING DATA MODE

Find the data storage order for your PLC in the following table, and setup the CHARACTER STRING DATA MODE.

- (I) Data Device Storage Order
- (II) Internal Word Byte LH/HL Storage Order
- (III) Internal Double-word Word LH/HL Storage Order

CHARACTER STRING DATA MODE(1-8) List

(I) Data Device Storage Order	(II) Internal Word, Byte LH/HL Storage Order	(III) Double-word Internal Word LH/HL Storage Order	Character String Data Mode
Storage from Initial data	LH order	LH order	4
		HL order	2
	HL order	LH order	5
		HL order	1
Storage from End data	LH order	LH order	6
		HL order	7
	HL order	LH order	8
		HL order	3

Chapter 6 - Initializing the GLC

I) Data Device Storage Order

E.g. Characters A B C D E F G H
 ① ② ③ ④

• Storage from Start Data

①	D100
②	D101
③	D102
④	D103

• Storage from End Data

④	D100
③	D101
②	D102
①	D103

II) Word Byte LH/HL Order

E.g. Characters A B C D
 ① ② ③ ④

• 16 bit Device LH Order

②	①	D100
④	③	D101

• 16 bit Device HL Order

①	②	D100
③	④	D101

• 32 bit Device LH Order

②	①	④	③	D100
---	---	---	---	------

• 32 bit Device HL Order

①	②	③	④	D100
---	---	---	---	------

III) Double-word Word LH/HL Order

E.g. Characters A B C D E F G H I J"
 ① ② ③ ④ ⑤

• 16 bit Device LH Order

②	D100
①	D101
④	D102
③	D103
⑤	D104

• 16 bit Device HL Order

①	D100
②	D101
③	D102
④	D103
⑤	D104

E.g. Characters "A B C D E F G H I J K L M N O P Q R S T"
 ① ② ③ ④ ⑤ ⑥ ⑦ ⑧ ⑨ ⑩

• 32 bit Device LH Order

②	①	D100
④	③	D101
⑥	⑤	D102
⑧	⑦	D103
⑩	⑨	D104

• 32 bit Device HL Order

①	②	D100
③	④	D101
⑤	⑥	D102
⑦	⑧	D103
⑨	⑩	D104

Relationship between K-tag Write Character Value and PLC Device

◆ 16 bit Devices

The GLC stores the character string from the start, as groups of 2, into one PLC Device.

When there are nine characters, they are arranged as shown below.

1 2 3 4 5 6 7 8 9 Null



Note: When the characters do not divide into 2 evenly, NULL is added at the end.

◆ 32 bit Devices

The GLC stores the character string from the start, as groups of 4, into one PLC Device.

When there are nine characters, they are arranged as shown below.

1 2 3 4 5 6 7 8 9 Null



Note: When the characters do not divide into 4 evenly, NULL is added at the end.

6.4 SET UP I/O

This section describes the communication setup with the Host (PLC) and the setup for any peripheral equipment. The SET UP I/O menu includes the SET UP SIO, SET UP PRINTER, SET UP TOUCH PANEL, COMMUNICATION SETUP, SOUND SETTINGS, EXPANSION SERIAL COMMUNICATION SETUP and EXPANSION SERIAL ENVIRONMENT SETUP menus.

6.4.1 SET UP SIO

This menu runs the settings related to PLC communication. Be sure to match the settings listed below with the SIO setup on the Host (PLC). The settings will vary depending on the PLC type.

Reference *GP-PRO/PBIII for Windows PLC Connection Manual (included with screen creation software)*

SET UP SIO

COMMUNICATION RATE	2400	4800	9600	19200	38400	57600	115200
DATA LENGTH	7	8					
STOP BIT	1	2					
PARITY	OFF	ODD	EVEN				
CONTROL	X-CNTRL	ER-CNTRL					
COMMUNICATION FORMAT	RS232C	4 LINE	2 LINE				

(Some PLCs may not be able to communicate at 57600 or 115200bps.)

COMMUNICATION RATE

The COMMUNICATION RATE (baud rate) is the data communication speed, measured in bits per second (bps), between the GLC and PLC. Match the COMMUNICATION RATE values in both the PLC and GLC. Depending on the rate selected, certain PLCs may not be able to be used.

Reference *GP-PRO/PBIII for Windows PLC Connection Manual*

DATA LENGTH/STOP BIT

For data communication, the DATA LENGTH must be set up as 7-bit or 8-bit data, and set up also the STOP BIT as either a 1-bit or 2-bit value.

PARITY

Set up whether no parity check, or an odd or even number parity check will take place during communication.

CONTROL

CONTROL prevents the overflow of data sent and received. Select either XON/XOFF control or ER (DTR) control.

COMMUNICATION FORMAT

Select one of the following options for the communication format: RS-232C, RS-422 (4 line), or RS-422 (2 line).



Note:

When using an RS422 cable and the Memory Link format, be sure to select the 4-line option.

Reference *GP-PRO/PBIII for Windows PLC Connection Manual (included with screen creation software)*

6.4.2 SET UP PRINTER

This setting is used to designate the type of printer that will be connected to the GLC.

```

SET UP PRINTER
-----
PRINTER TYPE
  NEC PR SERIES          HP LASERJET SERIES
  EPSON ESC/P (HIGH SPEED)
  EPSON ESC/P (HIGH QUALITY)
  PRINT          GRAY SCALING  COLOR
  BLACK/WHITE REVERSE  YES          NO
  
```

■ PRINTER TYPE

Printers that are compatible with NECPC-PR201/PL , EPSON ESC/P24-J84(C), HP Laser Jet PCL 4 commands can be used.

■ PRINT

Two selections [GREY SCALING] and [COLOR] are available. If you select [GREY SCALING], the same pattern will be applied to:

- Blue and Green
- Light blue and Red
- Purple and Yellow



- **Since HP LaserJet Series printers do not support color printing, be sure to designate [GREY SCALING].**
- **[GREY SCALING]'s printing patterns are less than the available color patterns (64 colors) and not all colors can apply to the [GREY SCALING] pattern-range. Therefore, characters with light (not dark) colors cannot be printed.**

■ BLACK/WHITE REVERSE

This setting is used for reversing the background and display color black/white color attributes. When the color is reversed, the background color is printed as black and the character color is printed as white.

<e.g.> When the background color is black and the display color is white.

When "BLACK/WHITE REVERSE" is selected.



When "BLACK/WHITE REVERSE" is **not** selected.



This setting is enabled only when a screen display is printed. Alarm or Recovery data output is printed always as black, regardless of the setting selected.

Chapter 6 - Initializing the GLC

6.4.3 SET UP TOUCH PANEL

Touch operation and Force Reset setup, and Display Device adjustments are made here. There may be differences on these settings depending of the GLC type.

SET UP TOUCH PANEL				SET	CANCEL
TOUCH OPERATION MODE	ONE POINT	TWO POINTS	NO SLIDE		
FORCE RESET	ON	OFF			
CONTRAST ADJUSTMENT	ON	OFF			
BRIGHTNESS ADJUSTMENT	ON	OFF			
USE TOUCH PANEL AFTER BACKLIGHT BURNOUT		YES	NO		

(Contrast and brightness settings are not applicable for some display devices.)

TOUCH OPERATION MODE

Designates either One Point, Two Point or No Slide. When No Slide is selected, dragging one's finger across the touch screen creates no screen response and only individually selected points will register.

FORCE RESET

Enables or disables the display of the menu bar (force reset page). When set to “Yes”, the menu bar will be displayed.

◆ To Display the Menu Bar

While holding down the bottom right corner (1) of the screen, press the upper right corner (2). At the same time, press the bottom left corner (3) to enter the FORCE RESET mode. To activate Reset, press the **RESET** button, and to change to OFFLINE Mode, press **OFFLINE**.

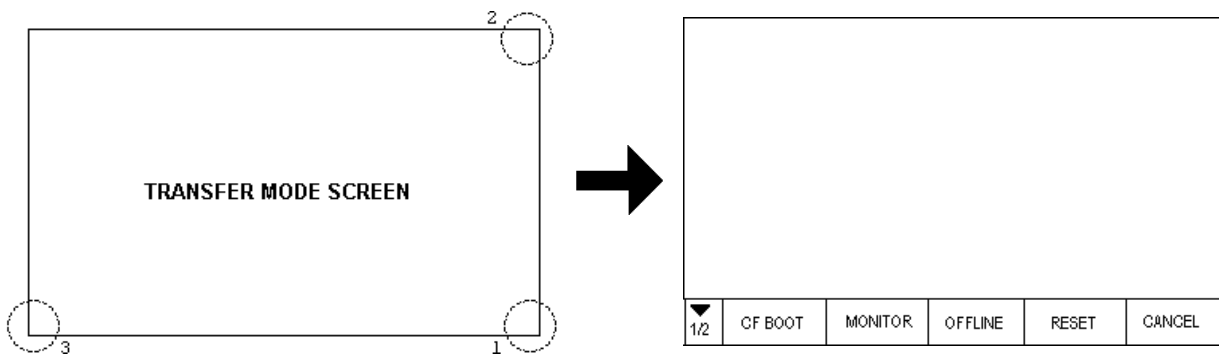

You can perform FORCE RESET in either RUN mode or OFFLINE mode.



- While the GLC is starting up, the Menu Bar will not display.
- Entering SYSTEM RESET is possible even when the PLC and GLC are not communicating.

CONTRAST ADJUSTMENT

This setting is not available with GLC-2400T.

BRIGHTNESS ADJUSTMENT

When set to ON, BRIGHTNESS ADJUSTMENT can be performed via touch input. Press the bottom left corner (2) of the screen while holding down the bottom right corner (1) to enter BRIGHTNESS ADJUSTMENT mode. Touch the left-side of the bar to brighten the display; touch the right-side of the bar to dim the display. This unit has four levels of adjustment.

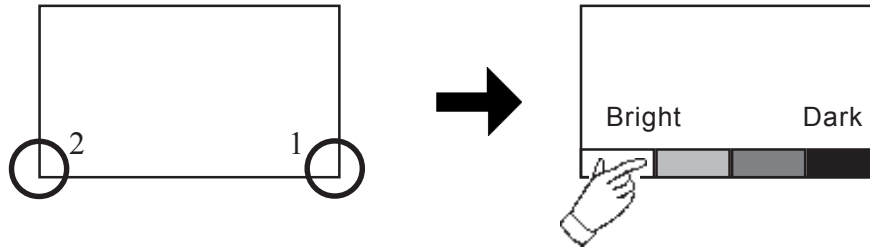

Note:

- To end BRIGHTNESS ADJUSTMENT mode, touch anywhere on the screen, except the bottom section.
- BRIGHTNESS ADJUSTMENT mode cannot be entered while the GLC is starting up.
- BRIGHTNESS ADJUSTMENT can be used even during RUN mode (PLC<-->GLC communication).

USE TOUCH PANEL AFTER BACKLIGHT BURNOUT

This option designates whether touch-operation is disabled or not when the backlight burns out.

If this selection is set to [OFF], touch-operation will be disabled when the backlight burns out, which prevents the GLC from sending input signals to the PLC.



Note:

- When the backlight burns out, the Status LED's orange light turns ON, and the System Data Area's "Status" bit 10*1 will turn ON.
- If the [SYSTEM RESET] option is set to [ON], only "System Reset" can still be performed by touch-operation in case of backlight burnout.
- If the backlight burns out when the GLC is OFFLINE, touch-panel operation is enabled, regardless of these settings.



Normally, the unit detects backlight burnout by monitoring the current flow, however, the unit may fail to detect this condition depending on the problem type the backlight has.

*1 Bit +6 (when using the Direct Access method), and bit +11 (when using the Memory Link method), will turn ON.

Reference GP-PRO/PBIII for Windows PLC Connection Manual (included with screen creation software)

Chapter 6 - Initializing the GLC

6.4.4 COMMUNICATION SETUP

The following explains the use of the retry command to deal with errors, including those that occur during GLC and PLC communication.

COMMUNICATION SETUP		SET	CANCEL
RECEIVE TIMEOUT (1-127)	[]	SECON	
RETRY COUNT (0-255)	[]		

RECEIVE TIMEOUT (1 to 127)

Sets the value used for the data reception timeout (PLC <--> GLC).

If the cable is not connected, data communication will Timeout after one second, regardless of this setting's value. The default is "10" seconds.



An error message may appear on your personal computer if:

- You transfer screens from your PC to the GLC after a PLC communication error has occurred and the error is not yet cleared.
- Your GLC's RECEIVE TIMEOUT value is set to 30 seconds or more.

RETRY COUNT (0 to 255)

Designates how many times the GLC tries to send data to the PLC when a PLC communication error occurs. An Error Message will appear on the GLC after the GLC tries to send data to the PLC the number of times set by this option. The default is "2".

6.4.5 SOUND SETTINGS

SOUND SETTINGS			SET	CANCEL
START-UP SOUND	BUZZER	SOUND		

START UP SOUND

Select the type of sound that is output when the GLC starts. If "BUZZER" is selected, the GLC's internal buzzer will be sound. If "SOUND" is selected, a sound will output from the speaker connected to the GLC.

6.4.6 EXPANSION SERIAL COMMUNICATION SETUP

The following explains the setup for communicating with a device connected to the Expansion Serial Interface. This setup screen will not display unless the communication protocol for the Expansion Serial Interface (specified with “SET UP EXPANSION SIO” of the GLC screen creation software package) is transferred to the GLC.

The screenshot shows a terminal-style interface for 'EXP. SERIAL SETUP'. At the top right are 'SET' and 'CANCEL' buttons. The parameters are as follows:

COMMUNICATION RATE	2400	4800	9600	19200	38400
DATA LENGTH	7	8			
STOP BIT	1	2			
PARITY	OFF	ODD	EVEN		

At the bottom is a numeric keypad (0-9), arrow keys (up, down, left, right), and a BS key.

COMMUNICATION RATE

The COMMUNICATION RATE refer to the data communication speed, measured in bits per second (bps), between the GLC and the device connected to the Expansion Serial Interface.

The supported communication rates vary depending on the connected device. Refer to the instruction manual of the connected device for more information. The initial setting varies depending on the communication protocol for the Expansion Serial Interface being transferred.

DATA LENGTH

Set the DATA LENGTH to 7-bit or 8-bit data.

STOP BIT

Set the STOP BIT to either 1- or 2-bit.

PARITY

Set the parity to no parity (OFF), or an ODD or EVEN parity check.

6.4.7 EXPANSION SERIAL ENVIRONMENT SETUP

The following setting varies depending on the communication protocol for the Expansion Serial Interface being transferred.

This section explains the case where “SERIAL CODE READER(LS)” is transferred.

Use this setting when a serial code reader is connected to the Expansion Serial Interface to read serial code data.

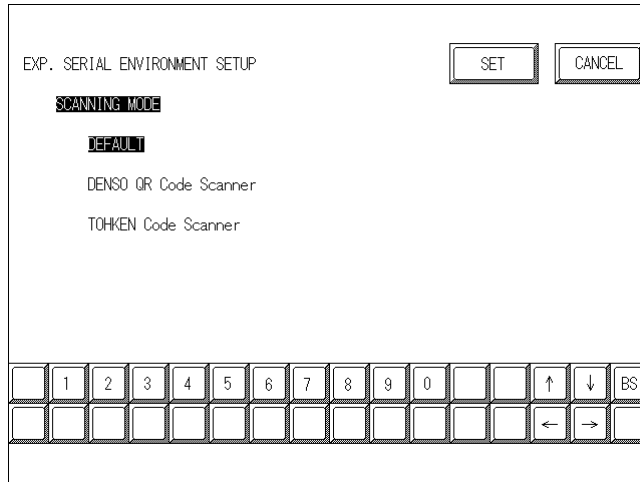

READ MODE

Select the READ MODE according to the scanner settings.

The communication format for each mode is shown below:

- Standard

Code data	Terminator (CR)
-----------	-----------------

- QR code scanner manufactured by Denso

Header (STX)	Code mark (7 bytes)	No. of digits (4 bytes)	Code data	Terminator (CR)	BCC (7 bytes)
--------------	------------------------	----------------------------	-----------	--------------------	------------------

- Code scanner manufactured by Tohken

Header (STX)	Code data	Terminator (CR + LF)
--------------	-----------	----------------------

6.5 PLC SETUP

Set up the GLC System Area and the Unit number in this screen. Because 1:1 and n:1 GLC connections utilize different settings, confirm your connection's needs before using any settings. The following assumes that the Direct Access format is used.



- The screens that appear will depend on the PLC type you selected in the screen creation software.

▼ **Reference** ▲ *GP-PRO/PBIII for Windows PLC Connection Manual (included with screen creation software)*

- When the GP-PRO/PBIII for Windows Ver 3.0 "Simulation" feature is used, the OPERATION SURROUNDINGS menu cannot be used.

6.5.1 SET UP OPERATION SURROUNDINGS(1:1/n:1)

Enter the PLC System Data Area and the Unit Number settings here. The same options are available for both 1:1 and n:1 (Multi-link) connections.

For an n:1 (Multi-link) Connection, System Data Area settings must be setup for each GLC connected to the PLC.

▼ **Reference** ▲ *GP-PRO/PBIII for Windows PLC Connection Manual (included with screen creation software)*

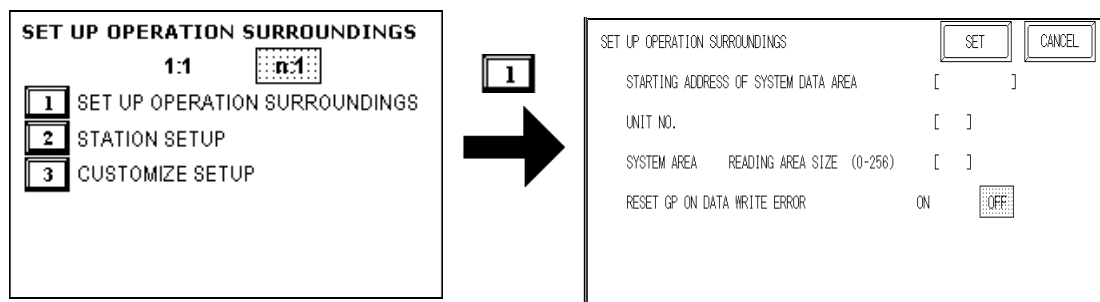

STARTING ADDRESS OF SYSTEM DATA AREA

Setup the System Data Area's Start Address. Device addresses that can be allocated will differ depending on the type of PLC used.

▼ **Reference** ▲ *GP-PRO/PBIII for Windows PLC Connection Manual (included with screen creation software)*

UNIT NO.

Enter the PLC UNIT number here. Check that it matches the one set up in the PLC.

SYSTEM AREA READING AREA SIZE (0-256)

When using a Block Display Trend Graph, setup the Reading Area Size (in word units) to match the Trend Graph's data size. Use this feature when you wish to allocate the Reading Area in the PLC Data Register (D), or Data Memory (DM).



If you are not using the Reading Area, leave the 0 default values intact. This will allow you to perform high speed data communication.

RESET GLC ON DATA WRITE ERROR

Designates the mode which enables you to cancel the error from the error display when the Write error occurs.

6.5.2 STATION SETUP(n:1)

STATION SETUP, required with an n:1 (Multi-link) setup, checks whether data communication is being performed correctly between the GLC and the PLC.

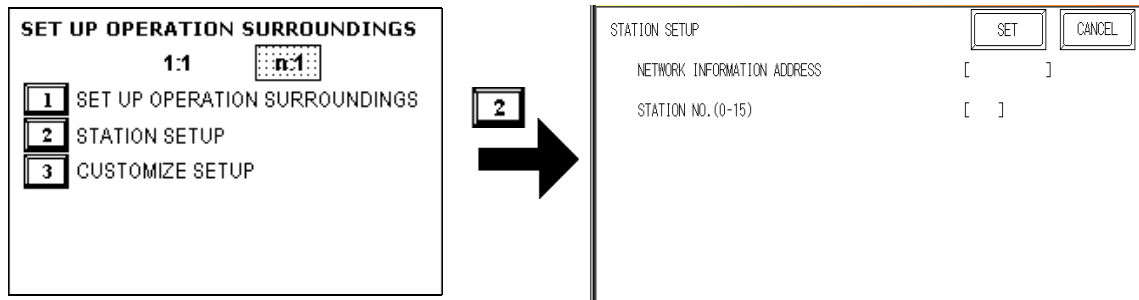

NETWORK INFORMATION ADDRESS

With an n:1 (multi-link) connection, the Network Information setting uses 2 words for its data. These two (2) words consist of a Connection List and a Validation List (described later in this section). These areas are allocated in the PLC's Data Register (D) or Data Memory (DM). Addresses which can be allocated will differ depending on the PLC type.

Reference *GP-PRO/PBIII for Windows PLC Connection Manual* (included with screen creation software)

PLC Data Register

+0	CONNECTION LIST	PLC-->GP
+1	VALIDATION LIST	GP-->PLC



In the NETWORK INFORMATION ADDRESS, setup the same address to all the GLC's connected to the same link unit. Also, when the link unit has 2 ports, be sure they do not use the same address.

◆ Connection List

The word address for the Connection List sets up the number of GLC's connected to the PLC, which must be previously entered in the PLC. When these GLC's are connected to the PLC, the corresponding PLC bit number for each GLC Station (see below) turns ON.



When the GLC is connected to the PLC, and the option of GLC-only correspondence ends and OFFLINE mode is entered, the GLC Station Number then turns the corresponding PLC bit OFF.



For example, when 4 GLC units— shown by bits 0, 2, 3, and 5—are connected, 002D (h) is written here.

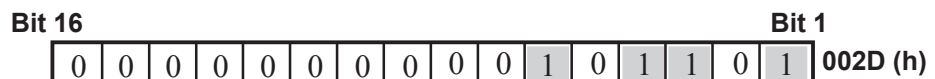



- **Be certain to setup this data before running.**
- **Turn all bits not related to the GLC OFF.**

◆ Validation List

This area responds to the correspondence from each connected GLC. In the Validation List, when the same bit numbers as the Connection List turn ON, the correspondence is accepted. The Station Numbers of the communicating GLCs turn their corresponding PLC bit number ON.

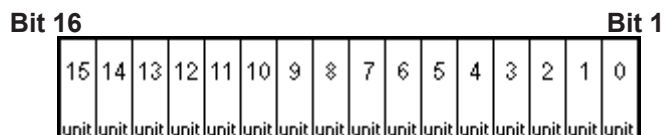

If the correspondence between the GLC and PLC is correct, the same value as in the Connection List is written to the Validation List.

For example, the value 002D (h) in the Connection List, setup as the 0 bit, 2 bit, 3 bit, and 5 bit, writes to the Validation List.

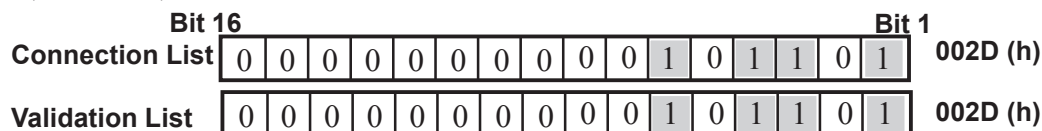

- **When the Connection List and Validation List do not match, a COMMUNICATION ERROR occurs. Check the setup again.**
- **When changing the connection, first turn all the bits OFF.**

STATION NO. (0-15)

This is the setup for the GLC Station Number mentioned above. The setup range is from 0 to 15, and the only other restriction is the GLC STATION NO. must be unique in the system. If STATION NO.'s are repeated, a COMMUNICATION ERROR occurs.



The STATION NO. is the number allocated to the particular GLC unit. This number is not related to the Link Unit Machine number.

6.5.3 CUSTOMIZE SETUP (n:1)

The Customize function modifies the n:1 (multi-link) connection's communication method to make it more efficient. To perform GLC<-->PLC communication efficiently, the user should first determine whether they wish to have Operation or Display priority set for the GLC. Based on this, the communication response speed can be upgraded. (However, this also depends on the complexity of the screen information displayed.)

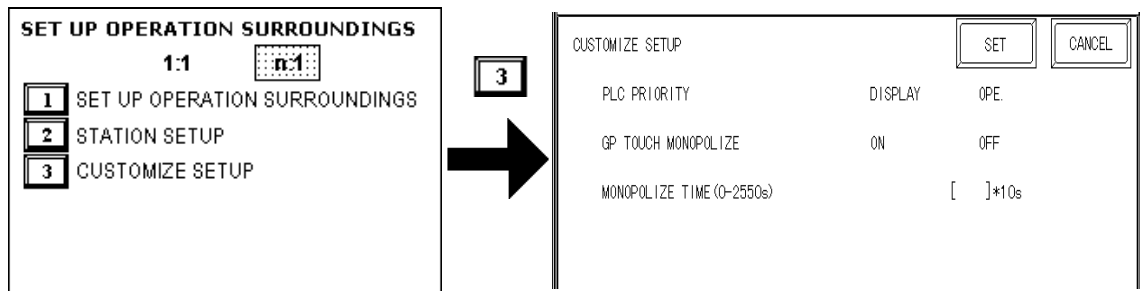

PLC PRIORITY

According to how the GLC is used, select either Operation priority (OPE.) or Display priority (DISPLAY).

Display

Setup the GLC to this option when using the GLC mainly as a monitor screen. The GLC will command a higher display speed as a result; however, the response time for the touch panel's operations will slow.

Operation

Set up the GLC to this option when using the GLC mainly as a monitor screen. The touch panel's numeric value input or switch function response speed will become higher as a result.

When "OPE" is selected, the response time for the touch panel's operation is quicker than the response time when the "DISPLAY." is selected, however, the display refresh cycle time will slow.



Important

- ***In a standard network setup, use the same settings for all connected GLC's.***
- ***To increase the display speed, be sure the addresses used are consecutive addresses. When bit addresses are used, use addresses that are consecutive to word units.***

Speed Difference between Display Priority and Operation Priority

When using the Mitsubishi Electric Corporation A3A PLC, with consecutive addresses (80 words, not including the System Area), the difference in reading speed is as shown in the following graphs.

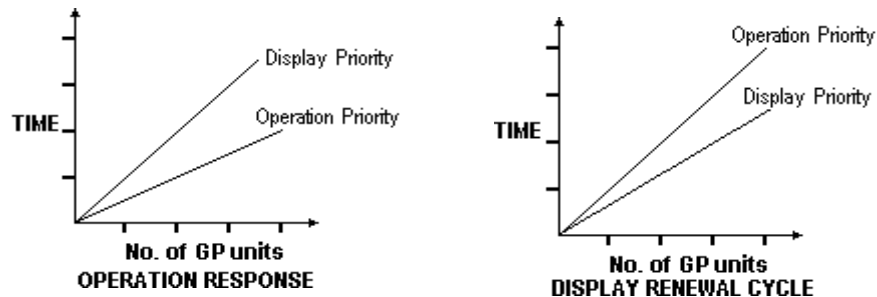

GLC TOUCH MONOPOLIZE

The monopolizing of touch panel use can be set ON or OFF. When you want to use the PLC exclusively with a Momentary operation setup on the touch panel, turn GLC TOUCH MONOPOLIZE ON.

When this setup is ON, the touch panel uses the PLC exclusively whenever the momentary operation setup on the panel is pressed. In this way, you can use the inching operation with a momentary switch. When you stop pressing the panel, exclusive use ends.

Reference *GP-PRO/PBIII for Windows PLC Connection Manual (included with screen creation software)*

MONOPOLIZE TIME (0-2550S)

Set Bit 7 of the System Data Area LS14 to ON to set monopolizing time.

This field controls the length of time for the monopolize process when no other touch panel operations are performed. The Monopolize process ends when the time set here elapses, and the 7th bit of word address LS14 turns OFF.

After cancelling GLC TOUCH MONOPOLIZE, it will return to n:1 (Multi Link) Communication.



- **Pressing the touch panel in the middle of the monopolize process interrupts the MONOPOLIZE TIME function, and ends exclusive use.**
- **When MONOPOLIZE TIME is set to 0, the monopolize function does not end automatically.**

Reference *For further information about the contents of System Data Area LS6 (status) and LS14 (control), refer to GP-PRO/PBIII for Windows PLC Connection Manual (included with screen creation software)*

Chapter 6 - Initializing the GLC

6.5.4 ETHERNET SETUP

This menu is for Ethernet settings. This information is used as setting data during GP setup or screen transfer, or, if the Pro-Server software is used, for the 2-Way Driver.

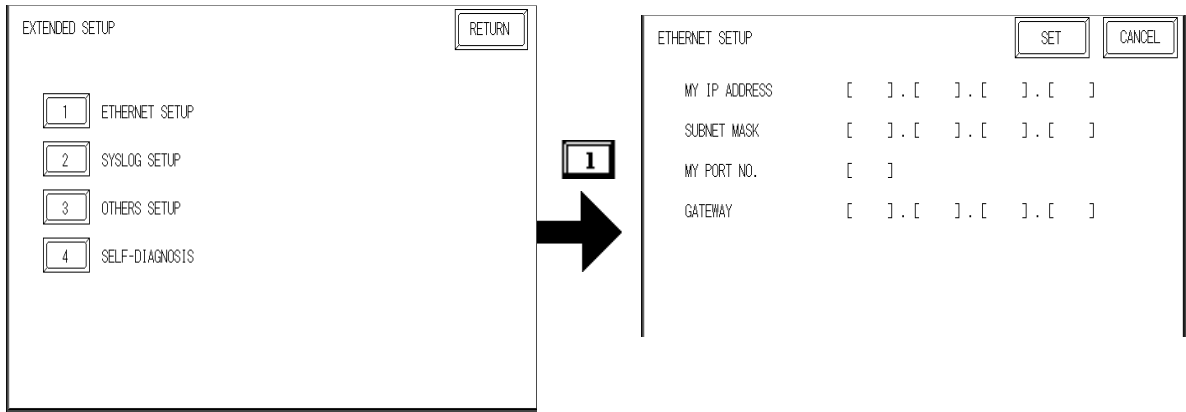

Important

- Enter the “ETHERNET SETUP” settings after receiving information from your network’s system administrator.
- Be sure to enter a unique IP address, not one used for other GLCs or by the host.

MY IP ADDRESS

Sets up the GLC’s IP address. The IP address is 32 bits and designated in four 8-bit units, entered in decimal.



Note:

To use Ethernet networking, click on [Initial Settings], [PLC Setup], [PLC Setup] and [Ethernet Setup].

SUBNET MASK

Sets the subnet mask. If you are not using a subnet mask, designate “0”.



Note:

To use Ethernet networking, click on [Initial Settings], [PLC Setup], [PLC Setup] and [Ethernet Setup].

MY PORT NO.

Sets the 2-Way Driver Port No. using a value from 1024 to 65535. Starting from the value entered here, a total of 10 consecutive ports can be used. The default setting is [8000].



Note:

To use Ethernet networking, click on [Initial Settings], [PLC Setup], [PLC Setup] and [Ethernet Setup] and select the corresponding Ethernet protocol Port No.

GATEWAY

Sets up the gateway’s IP address. Only a single gateway can be set up. If you are not using a gateway, enter “0”.

6.5.5 SYSLOG SETUP

These settings are used for outputting 2-Way driver's operation logs. Therefore, if you are not using the Pro-Server software, these settings are not necessary.

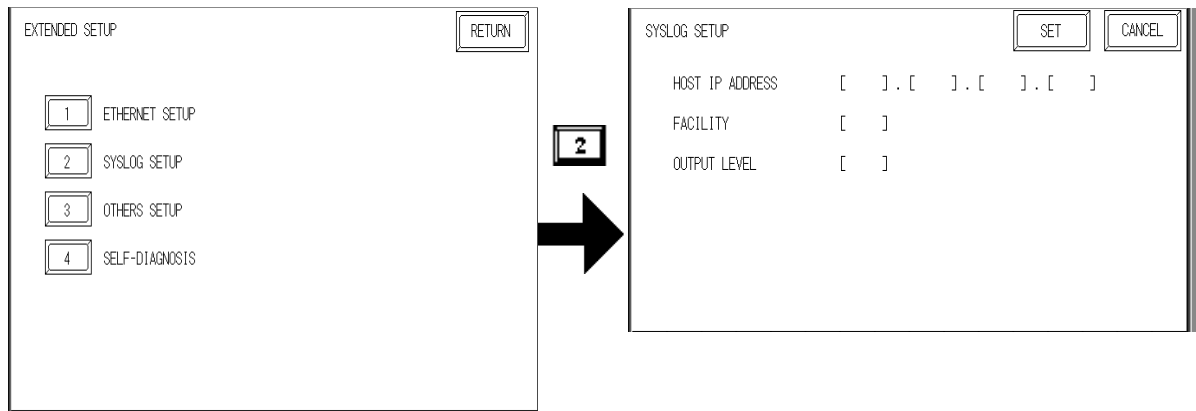

HOST IP ADDRESS

Sets up the IP address of the host computer, where the 2-Way driver's operation logs will be output.

FACILITY

Sets up the facility.

OUTPUT LEVEL

Sets up the output level.

Reference For details about Pro-Server and SYSLOG, refer to *Pro-Server with Pro-Studio for Windows Operation Manual* (included in the Pro-Server with Pro-Studio for Windows software package)

Chapter 6 - Initializing the GLC

6.5.6 OTHERS SETUP

Designates the GLC operation performed when a 2-Way driver error occurs.

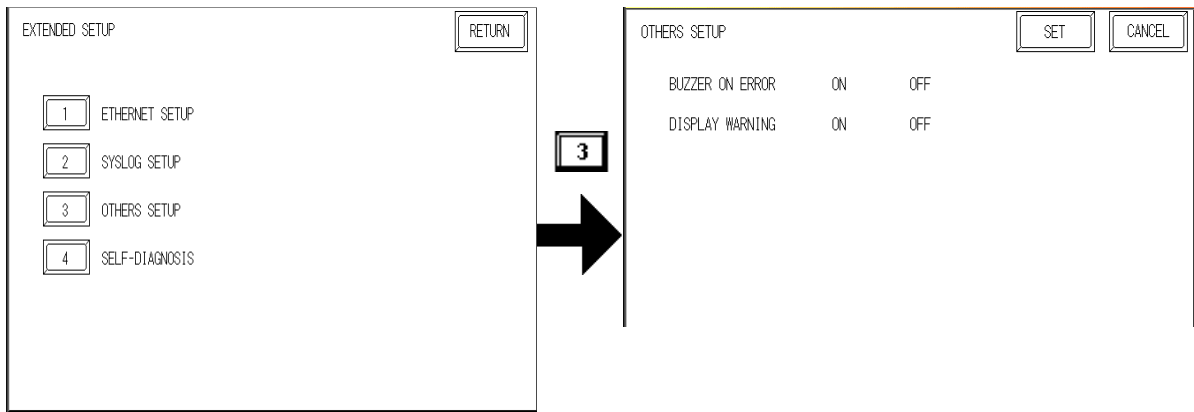

BUZZER ON ERROR

Enables/disables the buzzer sound output produced when an error related to the 2-Way driver operation occurs.

DISPLAY WARNING

Enables/disables the warning message display used when an error related to the 2-Way driver operation occurs.

6.5.7 SELF DIAGNOSIS

Runs the Self Diagnosis program for the Ethernet operation. The GLC must be connected to the Ethernet network prior to running this program.

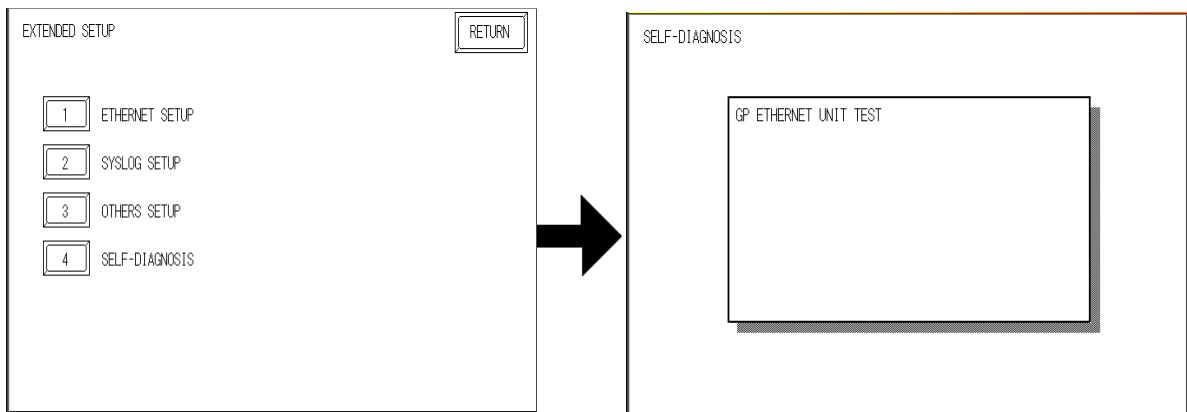

When there is no error detected, the message “OK” will appear. If an error is detected, the message “NG” will appear.

Be sure that this Self Diagnosis program is used only for the Ethernet operation. If you wish to run the general Self Diagnosis program, use [Main Menu]’s [Self Diagnosis] feature.

Reference 7.2 *Self Diagnosis*

6.5.8 Controller Settings

The following are setting for the Controller. In the “Controller Menu”, there are “Controller Settings”/“Controller Self Diagnostics”, “Copy to FEPRM”/“Flex Network Driver *1”. “Controller Settings” are selected here. For other entries, see the list below.

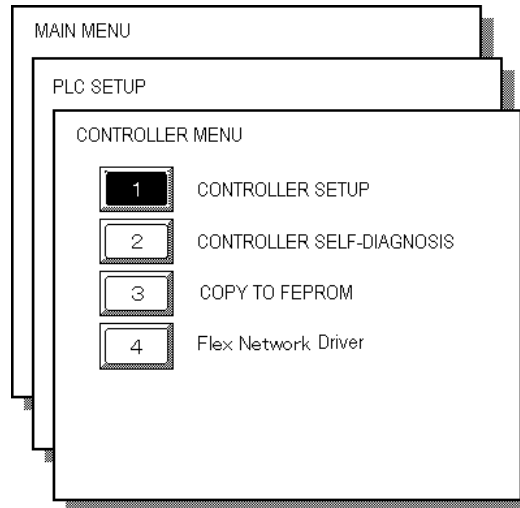

“Controller Self Diagnostics”

▼ **Reference** ▲ *7.2.3 List of Controller Self Diagnostics Items*

“Copy to FEPRM”

▼ **Reference** ▲ *Pro-Control Operation Manual (included with Pro-Control Editor)*

“Flex Network Driver”

▼ **Reference** ▲ *Pro-Control User’s Manual (included with Pro-Control Editor)*

*1 Will be displayed when you download logic program configured by Flex Network Driver.

Chapter 6 - Initializing the GLC

Information set by the Pro-Control Editor or GLC Controller Settings are stored in the GLC's nonvolatile memory. Although each entry in the Controller Settings has a default setting, they should be set according to your application.

CONTROLLER SETTING			DEF	SET	ESC
TARGET SCAN TIME	(10-2000ms)	[] ms			
PERCENT ALLOCATION	(0-50%)	[] %			
CONTROLLER STATE		START STOP DEFAULT			
STOP ON MINOR FAULT		OFF ON			
WATCHDOG TIMER	(100-3000ms)	[] ms			

	1	2	3	4	5	6	7	8	9	0			↑	↓	BS
													←	→	

Constant Scan

Constant Scan sets the Controller Operation Time Function and Display Feature Operation Time. Controller Operation Time Function is the time it takes for I/O reading, Logic Program execution and I/O writing. The setting range is between 10~2000 ms. When Constant Scan is set, Percent Scan will be done at 50%.

Percent Scan

Percent Scan sets the ratio of Controller Operation Time Function in Scan Time. The setting range is between 0 and 50%. When Percent Scan is set, Constant Scan is disabled.

Operation Mode when Power is ON

Sets the Operation Mode when the power is ON (Default, Run or Stop).

Continue in Anomaly Switch

Stops or executes a logic program when a minor anomaly occurs while a controller function is operating. Set this switch to "Continue" if you wish to continue operation as long as continuation is possible or set it to "Stop" if you wish to stop operation when an anomaly occurs.

Reference *Pro-Control Editor Online Help*

WDT (Watch Dog Timer) Setting

Sets the Watch Dog Timer for the Controller Operation Time Function and GLC Operation Time function to between 100 and 3000 ms. The input value in units of 100 ms. Inputting 0 is invalid.

6.6 INITIALIZE INTERNAL MEMORY

This section explains how to initialize the GP's internal data or a CF card inserted in the GP. Select one of the menu items, [INITIALIZE MEMORY] and [INITIALIZE CF CARD] selections in the [INITIALIZE MEMORY] menu.

6.6.1 INITIALIZE GLC MEMORY

This will erase all GLC screen data (internal memory). Back up SRAM will also be initialized.



- **You cannot cancel the Initialization procedure after pressing the Start key. Do not turn the power off when initializing.**
- **All data in SRAM will be erased.**
- **Initialization does not erase the SYSTEM SET UP, the SIO protocol, or the internal clock settings.**

To initialize the GLC internal memory, enter the common password **1101**, or the password entered in the SYSTEM SET UP screen.



Reference Chapter 5.3, "INITIALIZE-Standard Operation"

The time required for Initialization is between 10 and 20 seconds.

6.6.2 INITIALIZE CF CARD

Deletes all data in the CF Card installed in the GLC.



Initialization cannot be canceled once the START switch is touched.

Initializes the CF Card. Enter the common password "1101" or the password you designated in the "SYSTEM SET UP" menu.

Reference For details about entering the password's numeric values, refer to **5.3 INITIALIZATION**

6.7 SET UP TIME

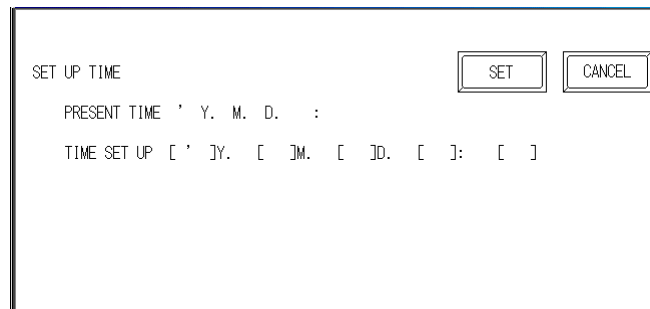

```
SET UP TIME
PRESENT TIME  Y. M. D.  :
TIME SET UP  [ ]Y. [ ]M. [ ]D. [ ]: [ ]
```

Sets the GLC's internal clock.

SET UP TIME

Enter date and time corrections to the date and time displayed in the PRESENT TIME.



The GLC's internal clock has a slight error. At normal operating temperatures and conditions, with the GLC operating from its lithium battery, the degree of error is 65 seconds per month. Variations in operating conditions and battery life can cause this error to vary from -350 to +90 seconds per month. For systems where this degree of error will be a problem, the user should be sure to monitor this error and make adjustments when required. "Hour" and "Minute" display on the screen but "Second" does not display.

6.8 SET UP SCREEN

This screen is used to enter the number for the initial screen displayed after powering up, the character size when in RUN mode, and other general screen items.

SET UP SCREEN		SET	CANCEL
INITIAL SCREEN NO.	(1-8999) [B]		
ALARM MESSAGE	V SIZE	1	2 4
	H SIZE	1	2 4
ONLINE ERROR DISPLAY		ON	OFF
FONT SETTING		I-ASCII	JAPAN KOREA TAIWAN CHINA
KANJI FONT QUALITY		STANDARD	HIGH(1) HIGH(1,2)

INITIAL SCREEN NO. (1-8999)

Set up the screen file number that will display first upon powering up. If the BIN option for DATA TYPE OF SCREEN NO in SYSTEM SET UP had been selected, enter a number from 1 to 8999. Or, if BCD was the option set up, then input a number from 1 to 1999.

ALARM MESSAGE

Set up the character size of the ALARM MESSAGE when the Alarm Bulletin is activated.

<When using single-byte characters>

1	2	4
V size=1; H size=1 16×8 pixels	V size=2; H size=2 32×16 pixels	V size=4; H size=4 64×32 pixels

<When using double-byte characters>

V size=1; H size=1 16×16 pixels	V size=2; H size=2 32×32 pixels	V size=4; H size=4 64×64 pixels
------------------------------------	------------------------------------	------------------------------------

ONLINE ERROR DISPLAY

Set up whether or not error messages display during RUN mode.

Chapter 6 - Initializing the GLC

FONT SETTING

Selects the font type displayed on the GLC screen during operation.

KANJI FONT QUALITY

Designates the font display quality for enlarged characters.

◆ When [FONT SETTING] is set to [JAPAN]

Single-byte characters will remain 8x16-dot characters when they are enlarged.

Double-byte characters are displayed as:

- | | |
|------------|---|
| [Standard] | Here, characters are displayed using 16x16-dot “blocks”. When enlarged, this font will remain a 16x16-dot character. (Compatible with GP-*30 series units.) |
| [HIGH] | When enlarged to double size, Level 1 JIS Kanji Code characters are displayed as 32x32-dot characters. Level 2 JIS Kanji Code characters remain 16x16-dot characters. (Compatible with GP-*50 series and GP-70 series units.) |
| [1,2] | When enlarged to double size, both Level 1 and Level 2 JIS Kanji Code characters are displayed as 32x32-dot characters. |

◆ When [FONT SETTING] is set to any other type (i.e. CHINESE, I-ASCII, KOREA or TAIWAN)

- | | |
|-------------|--|
| [Standard] | Half-size (single-byte) characters are displayed as 16x8-dot characters. Full-size characters, regardless of the display size used, will always be displayed as 16x16-dot characters. When enlarged, this font will stay as 16x16-dot character. (Compatible with GP-*30 Series units) |
| [HIGH(1)] | All half-size (single-byte) characters (ASCII code: 21h to 7Dh, i.e. alphanumeric characters) except “^” and “‘” will display as high quality characters. <ul style="list-style-type: none">• 16x16-dot or larger characters will display as high quality 16x16 fonts.• 32x32 or larger characters will display as high quality 32x32 fonts. Full-sized (double-byte) characters will display as 16x16-dot characters and remain 16x16-dot characters when enlarged. |
| [HIGH(1,2)] | All single-byte characters (ASCII code: 21h to 7Dh, i.e. alphanumeric characters) except “^” and “‘” will display as high quality characters. <ul style="list-style-type: none">• When 16x16 dots are used for a character, it will display as a high quality 16x16 character.• When 32x32 or larger dots are used for a character, the character will display as a high quality 32x32-character. Full-sized (double-byte) characters (i.e. [KOREA], [TAIWANESE] and [CHINESE]) will display as 32x32-dot characters when enlarged to 32x32-dot or larger characters. |

Chapter

7 RUN Mode and Errors

1. GLC RUN Mode
2. SELF-DIAGNOSIS
3. Troubleshooting
4. Error Messages

7.1 RUN Mode

There are two ways of entering the GLC's RUN mode; immediately after plugging in the unit's power cord, or from the GLC's OFFLINE mode.

7.1.1 After Connecting the Power Cord

The method of GLC startup will vary, depending on the "START TIME" setting in the "Initialization Settings" / "System Setup" area.

■ When START TIME is set to "0"

When the GLC's power cord is connected, the version information screen shown below will appear. Next, the screen designated by the initialization screen file number ("Initialization Settings" / "System Setup" area) will appear, and the GLC will start to communicate with the PLC.

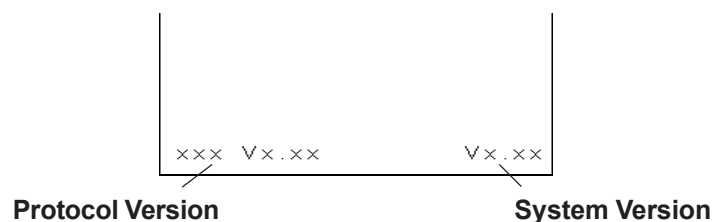

■ When START TIME is set to any value other than "0"

In this case, when the GLC's power cord is connected, the following version information screen will appear. In the top right corner of the screen, a value will appear and count down the number of seconds designated by the "START TIME" setting. Next, the screen designated by the initialization screen file number ("Initialization Settings" / "System Setup" area) will appear, and the GLC will start to communicate with the PLC.

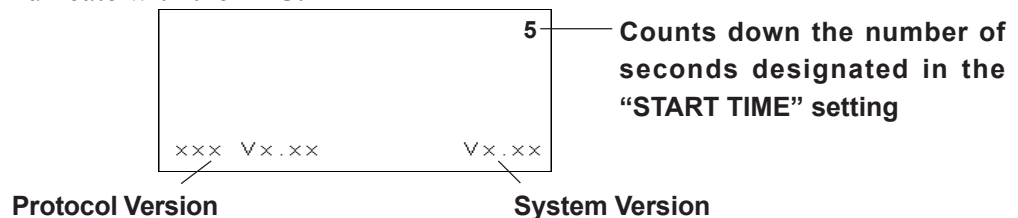

Note: There is a possibility that the screens shown above may not display in the beginning depending on the display device's start-up time.

Chapter 7 - RUN Mode and Errors

7.1.2 Via OFFLINE Mode

Touch the MAIN MENU's RUN selection to start your downloaded "project". The INITIALIZE area's SET UP SCREEN feature designates the first screen that appears in RUN mode, and, after this screen appears, communication with the PLC begins. If, however, the designated initial screen has not been created, or does not exist, the above display will remain.

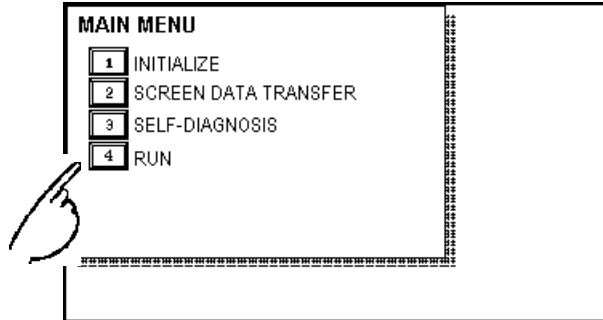

Note: To enter OFFLINE Mode, simply touch the top left corner of the GLC's screen within 10 seconds after connecting the GLC's power cord.

E.g. After powering up the GLC, the initial screen that appears is equipped with a built-in (invisible) switch in the top left corner. Touch this switch within 10 seconds to change the GLC from RUN to OFFLINE mode.

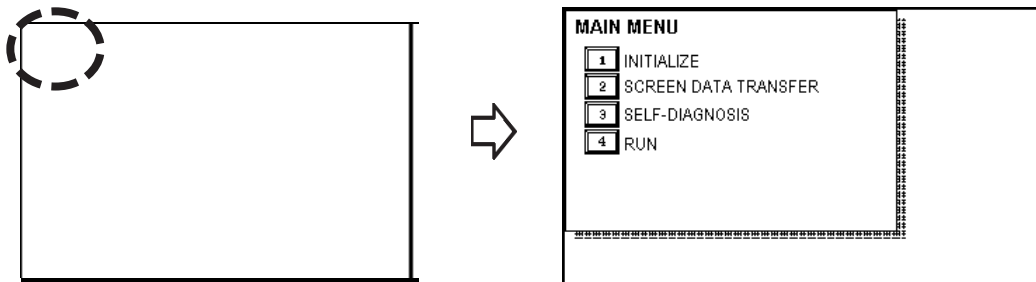

7.2 SELF-DIAGNOSIS

The GLC unit is equipped with a number of self-Diagnosis features used to check its System and Interfaces for any problems.

7.2.1 SELF-DIAGNOSIS ITEM LIST

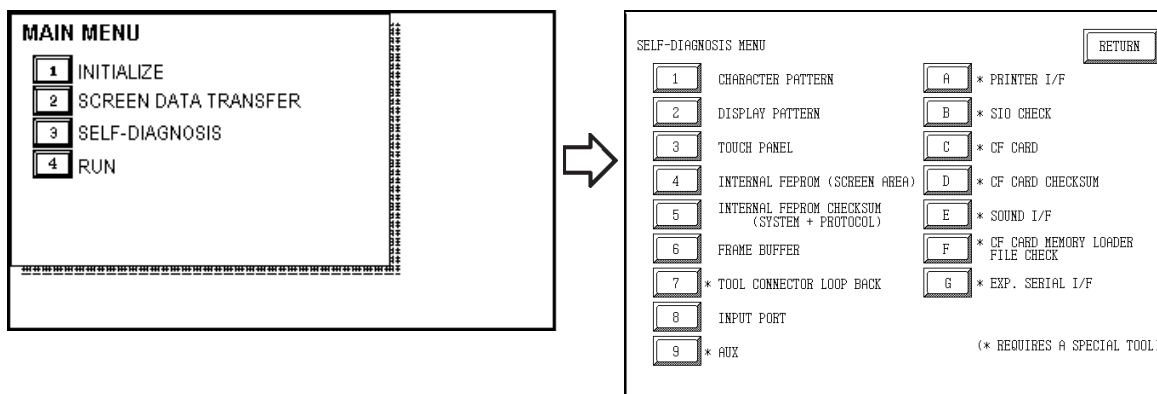

- 1 Checks the characters inside the internal Character ROM.
- 2 Checks all the figures and tiling patterns.
- 3 Checks each GLC touch panel square.
- 4 Checks the internal hard disk contents (FEPRM).
- 5 Checks the System and Protocol of the GLC Internal Memory (FEPRM).
- 6 Checks the internal display memory (Frame Buffer).
- 7 *Checks the Tool Connector control lines and send/receive lines.
- 8 Checks the Input Port. (for Digital's maintenance use only)
- 9 *Checks the AUX control line*².
- A *Checks the printer interface.
- B *Checks the RS-232C and RS-422 send/receive lines.
- C *Checks the status of the CF Card.
- D *CF Card Checksum.
- E *Checks the status of the GLC's Sound Output feature.
- F *Checks the status of the CF Card Memory Loader File.
- G *Checks the status of the Expansion Serial I/F.

*1 This item requires that the user special equipment (cable, connector, etc.).

*2 This setting is disabled, since the GLC2400 unit does not support this feature.

Chapter 7 - RUN Mode and Errors

7.2.2 SELF-DIAGNOSIS - Details

This section explains the contents of SELF-DIAGNOSIS. For information on how to operate the Screen, **Reference** Chapter 5, "OFFLINE Mode"; for information about how to set up the Special Tools, **Reference** Chapter 3, "Installation and Wiring".

CHARACTER PATTERN

Checks each font's pattern and kanji-characters' ROM. Used when kanji-characters do not display. If there is no error, the message [OK] will appear, if there is an error, the message [NG] will appear.

DISPLAY PATTERN

Used when the buzzer will not sound and when the device contents will not display correctly to check the drawing function. It does this by running checks on the various screen pattern displays (8 screens), the ON/OFF Display, and KANJIROM CHECKSUM. When the ON/OFF Display is checked, the Buzzer ON/OFF check is run simultaneously. If KANJIROM CHECKSUM is normal, **OK** displays; if there is a problem, **NG** displays.

TOUCH PANEL

Touch Panel check. Checks if each touch cell highlights when pressed.

INTERNAL FEPROM CHECKSUM (Display Area)



- **If you run this check menu, all screen data that have been created will be deleted. Therefore, be sure to back up data prior to running this check.**
- **When this check menu is completed, you need to initialize the internal memory (FEPROM).**

This menu is used for checking the internal FEPROM. Use this check menu when an error related to screen display occurred. When using this check menu, you need to enter the password *1.

While checking, the screen display will change in the following order.

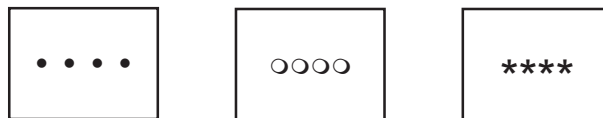

If there is no error, the message [OK] will appear, if there is an error, an error message will appear.

The number of the symbol marks (i.e. "OOOO", etc.) shown on the screen may vary depending on the GLC type.

The symbol mark "O" indicates the GLC is operating the erase checking.

The symbol mark "*" indicates the GLC is operating the R/W checking.

*1 Enter either the password you have designated in the "INITIALIZE" screen or the common password "1101".

INTERNAL FEPROM CHECKSUM (System & Protocol)

The Internal FEPROM System and Protocol check searches for any problems that may arise during operations. When running the check, the screen will change as follows.

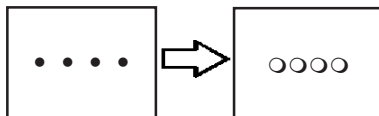

When the FEPROM is normal, **OK** displays; if there is a problem, the screen stops in the middle of operation. This check does not erase the System or Protocol.

FRAME BUFFER

The Frame Buffer (display memory) Check looks for any display problems that may develop. When everything is normal, **OK** displays; when there is a problem, an error message displays.

TOOL CONNECTOR

Use the Tool Connector Control line and Send/Receive line check when the GLC cannot send and receive data from the PC. To run the check, connecting a *Tool Connector Check Loop Back Cable* (Dsub9 pin, pin-side) mounted to the *Downloading Cable* (provided in the software package) is necessary.

When everything is normal, **OK** displays; when there is a problem, an error message displays.

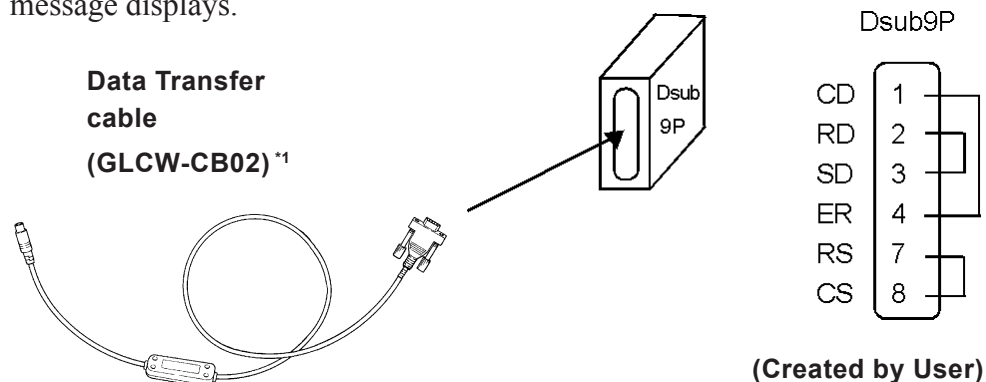

INPUT PORT

Used for Digital's maintenance.

AUX

Checks the AUX control line. Used when an inching output error or a monitor output error occurred. To enable this check menu, you need to connect the PLC input unit.

▼ Reference ▲ 2.3.3 AUX I/O and Sound Output

This check uses the input unit's LED.

The LED turns ON in the following order.

- 1) RUN, ALARM, and then BUZZ.
- 2) When all LED turn ON, they start to turn OFF in the same order as they turned ON.
- 3) When all LED turn OFF, the check has been completed.

Chapter 7 - RUN Mode and Errors

PRINTER I/F

Checks the printer I/F. Used when the printer does not function properly. You need to connect the printer prior to using this checking menu.

Connecting the printer buffer may cause an error, therefore, connect the GLC and the printer directly.

If there is no error, (ASCII Code: 20 to 7D<HEX> and A0 to DF<HEX>) will be output (printed) and the message [OK] will appear on the screen. If there is an error, an error message will appear.

SIO CHECK

Checks the RS-232C and RS-422 SIO lines for areas where communication problems develop. In the menu, select which check to run. To run the check, connecting the SIO cable is necessary. If all is normal, **OK** displays; if there is a problem, an error message appears.

The SIO cable wiring is as shown below. (RS-232C, RS-422 common)

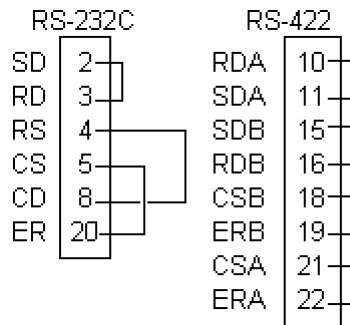

CF CARD

Checks the CF Card's Read/Write. Prior to using this check menu, you need to insert the CF Card in the GLC. The CF Card needs to have more than 1K bytes usable space. If there is no error, the message [OK] will appear. If there is an error, an error message will appear.

CF CARD CHECKSUM

Takes the Checksum of the CF Card's files and operates the check. Prior to using this check menu, you need to insert the CF Card in the GLC.

This check menu can check the following files.

- Filing Data
- CF Card's Image Data
- CF Card's Sound Data

When the check is finished, the following items will appear on the screen.

- The number of checked files
- The number of files that have an error
- The file name where the most recent error occurred

Chapter 7 - RUN Mode and Errors

SOUND I/F

Checks if Sound Output operates. Prior to using this check menu, connect the speaker to the GLC. The first three notes of the musical scale (do, re,mi) will sound.

CF CARD MEMORY LOADER FILE CHECK

Checks the CF Card's Memory Loader Tool when it does not start. If there is no error, the message [OK] will appear. If there is an error, the message [NG] will appear.

EXPANSION SERIAL I/F

Checks the Send/Receive line of the Expansion Serial Interface when an abnormality occurs. To run the check, you must connect the SIO cable. If all is normal, the message [OK] appears. If there is a problem, an error message appears.

The SIO cable wiring is as shown below.

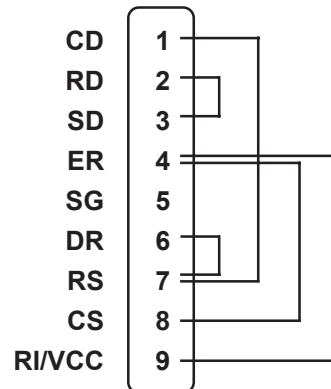

Chapter 7 - RUN Mode and Errors

7.2.3 CONTROLLER SELF-DIAGNOSIS

The Pro-Control Editor or GLC controller setting data is written to non-resident memory. Each of the setting items below is assigned a default value, however be sure that your own settings are entered, if necessary.

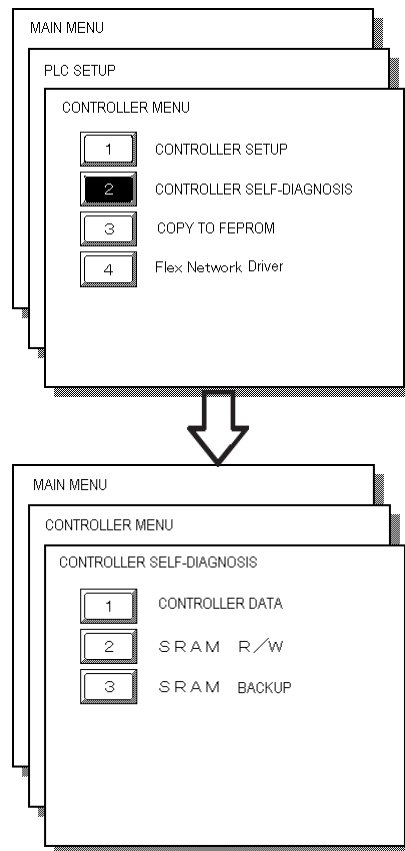

CONTROLLER DATA

Shows the current controller version data.

SRAM R/W

Performs an SRAM Read/Write check. Writes the data required to perform the backup SRAM check.

SRAM BACKUP

Be sure to perform the SRAM R/W check prior to performing this check. Then, after turning OFF the GLC unit's power and then ON again, perform this check.



Performing these checks will delete all resident SRAM data.

7.3 Troubleshooting

This section describes how to find and resolve problems that may occur on the GLC. If there is a problem with the PLC, please refer to the corresponding PLC manual.

7.3.1 Possible Types of Trouble

The following items are problems that may occur while using this unit.

(A) No Display

The screen will not display even when the unit is powered On. Also, during RUN mode, the screen disappears.

(B) No GLC/HOST Communication

The GLC unit cannot extract data from the host. An error message may appear on the screen as a result.

Reference *This chapter's "Error Messages"*

(C) Touch Panel Does Not Respond

The touch panel does not react when pressed, or the reaction time is very slow.

(D) Buzzer Sounds when GLC power is turned ON

The GLC goes to the OFFLINE mode unexpectedly while operating, or the GLC automatically goes to the OFFLINE mode when the power is turned ON.

(E) OFFLINE displays During RUN Mode

The GLC's buzzer will sound intermittently after power is first turned ON.

For these first four problems, see the troubleshooting tables on the following pages.

For the last problem (D), a SYSTEM ERROR may have developed while displaying the OFFLINE mode screen.

Reference *This chapter's "Error Message Details"*

Be sure that no object has touched the screen accidentally if the GLC goes to the OFFLINE mode without displaying an error message when the power turned ON. If any object may have possibly touched the top left corner of the screen within 10 seconds after the power turned ON, that may cause the GLC to go OFFLINE.

For other types of Flex Network problems,

Reference *Flex Network User Manual*



Note: The explanations given here assume the origin of the problem is the GLC unit. For host (PLC) related problems, refer to that unit's Operation Manual.

Chapter 7 - RUN Mode and Errors

7.3.2 No Display

Follow the flowchart below when the screen does not display when powering up, or the screen turns OFF by itself during RUN mode, to find an appropriate solution.

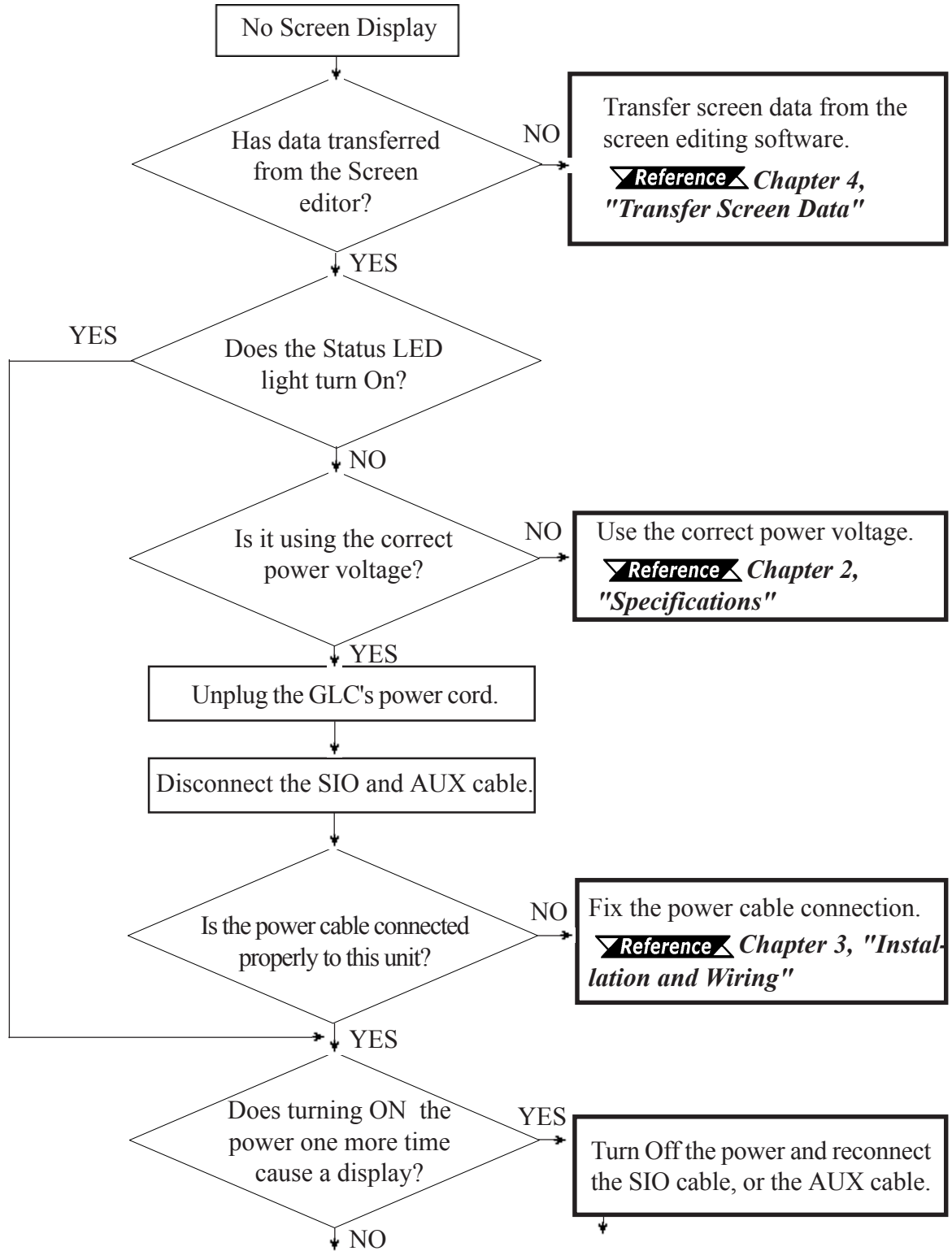

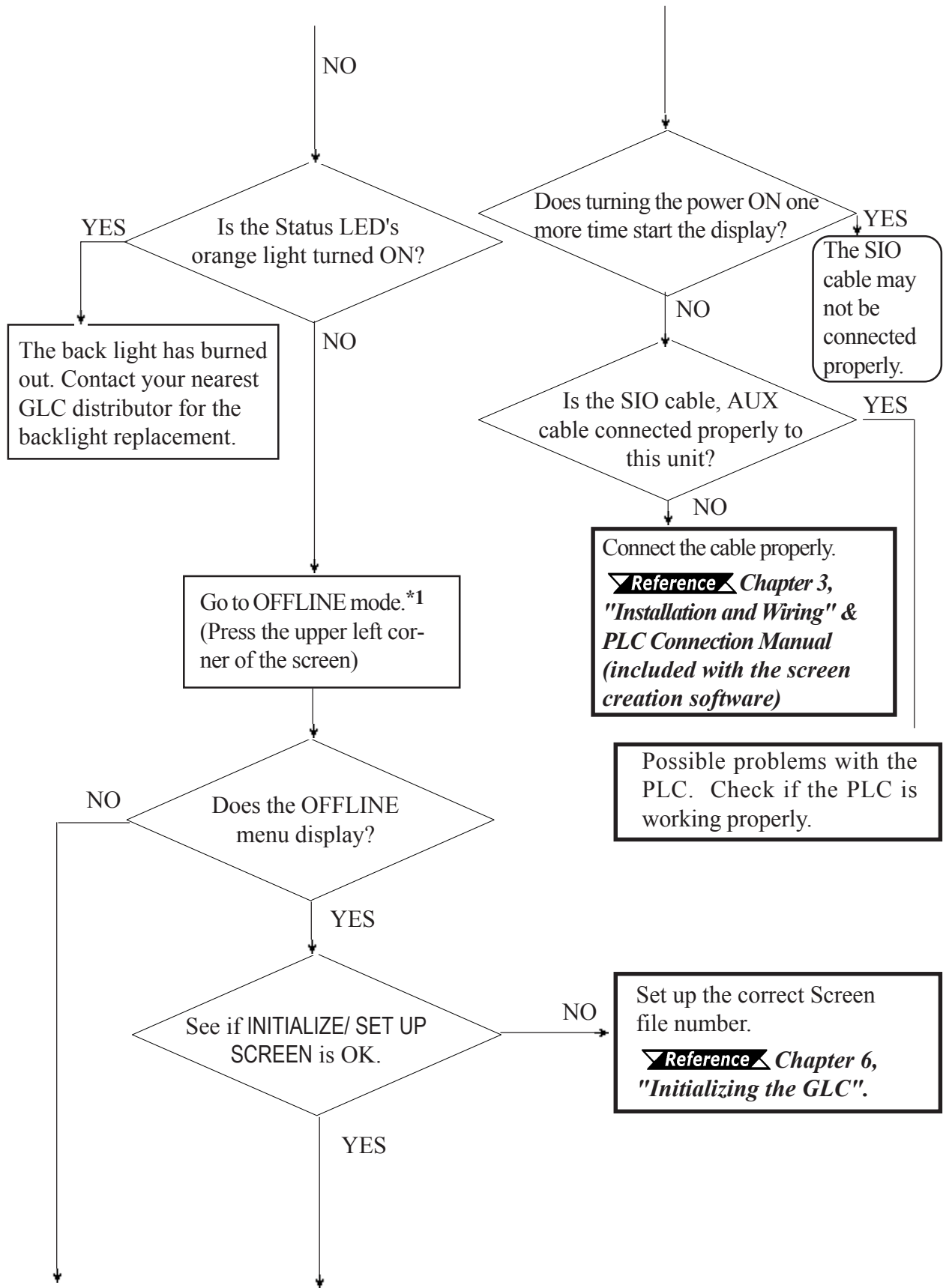

**1 To make the OFFLINE screen appear, turn the power OFF, then ON, and press the upper left corner of the screen within 10 seconds.*

Chapter 7 - RUN Mode and Errors

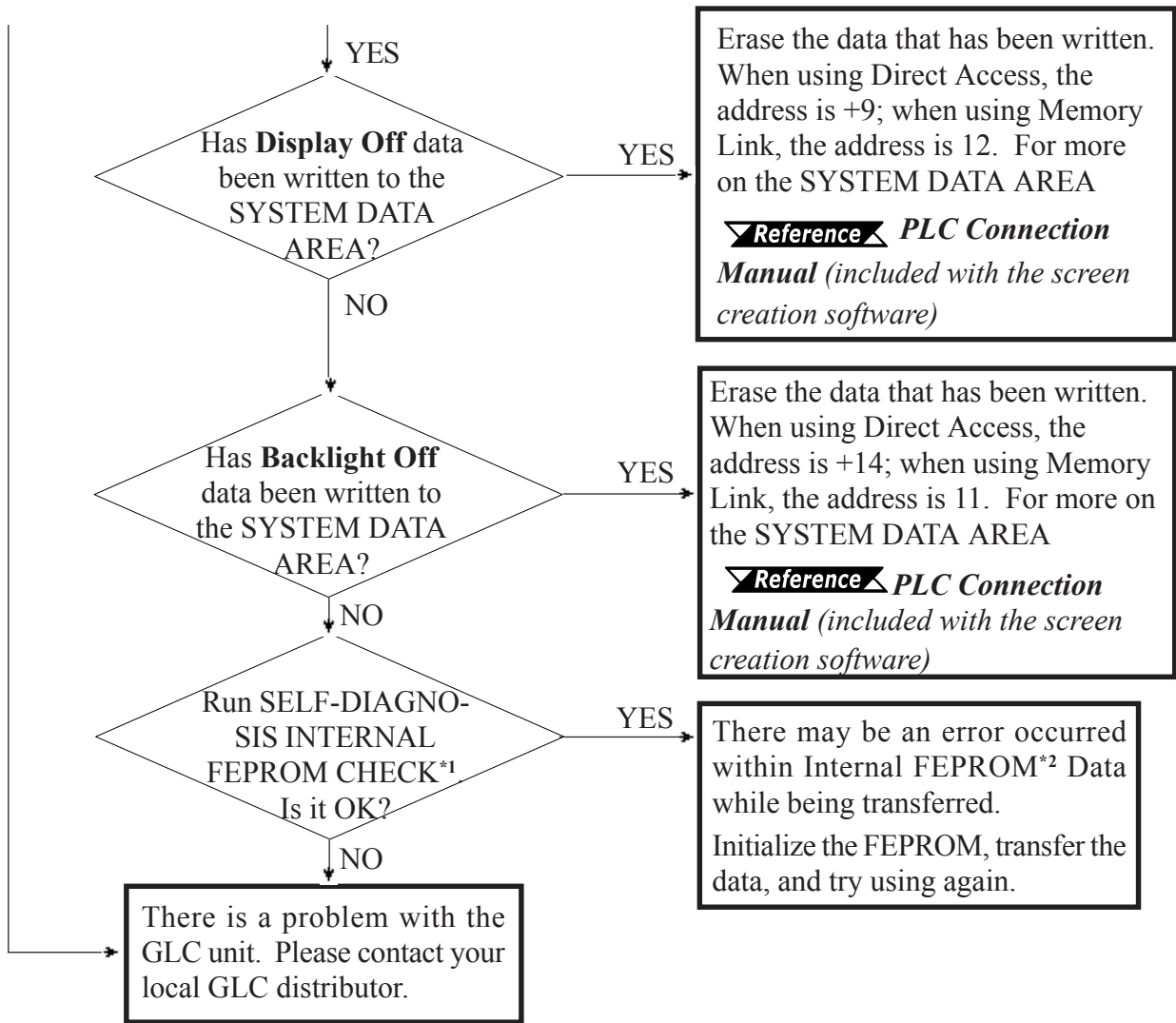

**1 When you run the SELF-DIAGNOSIS area's FEPR0M CHECK , all screen data is erased. Therefore, be sure to make a backup of all GLC screens prior to performing this check.*

**2 Also known as "FEPR0M" (Flash Electronic Erasable Programmable Read Only Memory).*

7.3.3 No GLC/Host Communication

When the GLC will not communicate with the host PLC, follow the flowchart below to find both the cause of the problem and a suitable response.

Or, if an error message displays on the screen, check the error code (refer to the *Error Messages* section in this chapter) to find the appropriate solution.

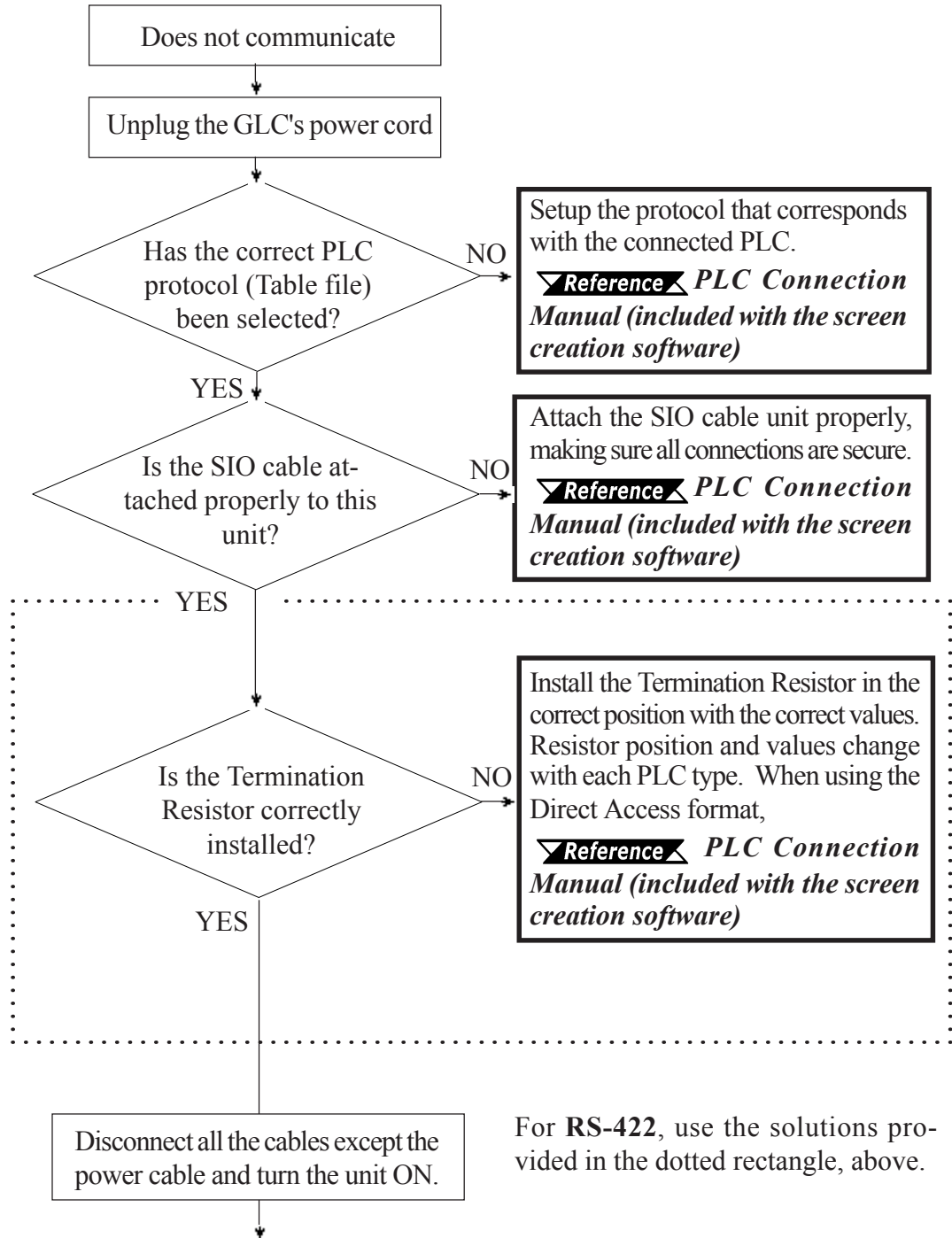

Chapter 7 - RUN Mode and Errors

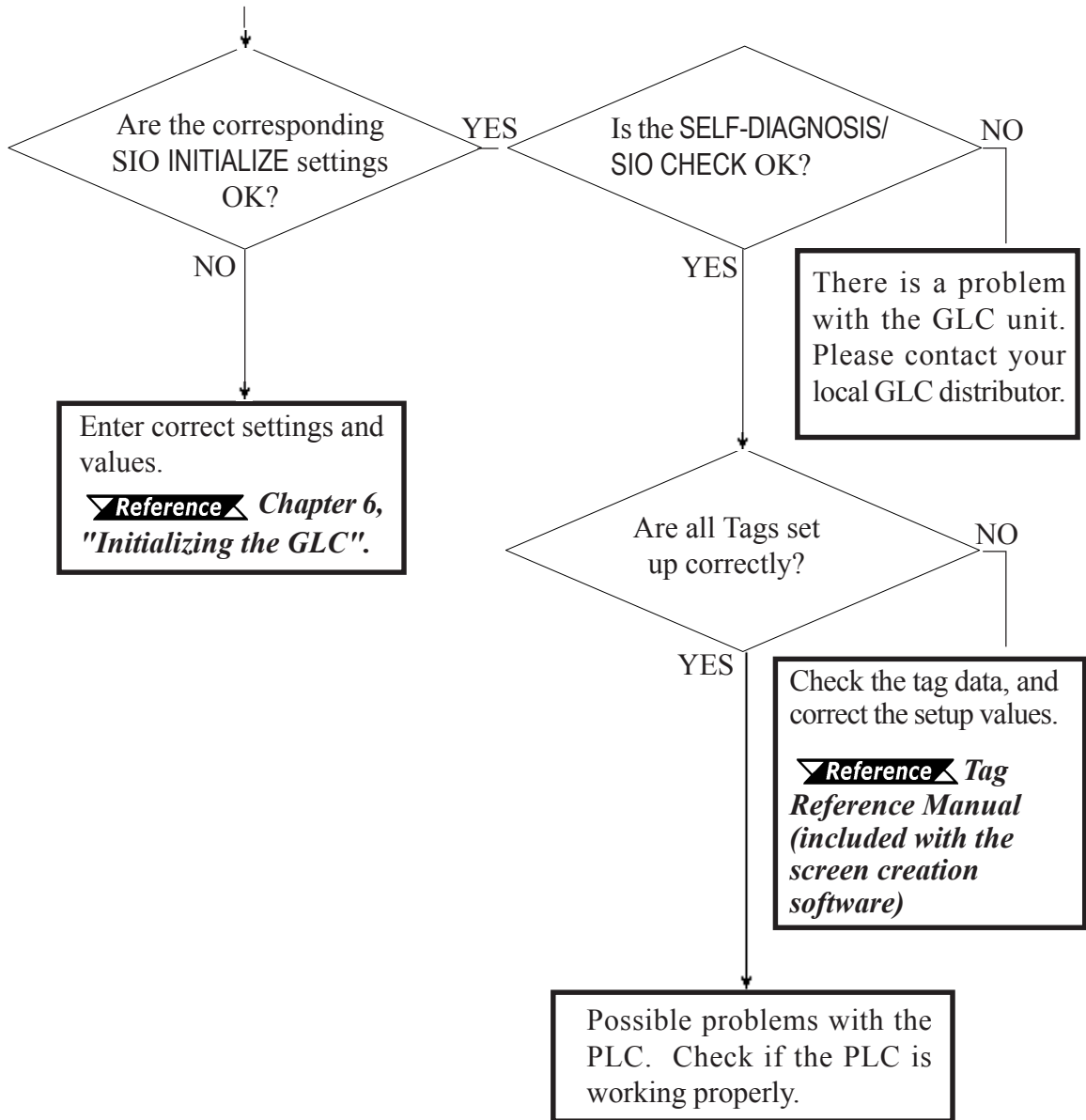

7.3.4 Touch Panel Does Not Respond

When the touch panel does not respond, or its response time is very slow after it is pressed, please use the flowchart below to find the origin of the problem, and the appropriate solution.

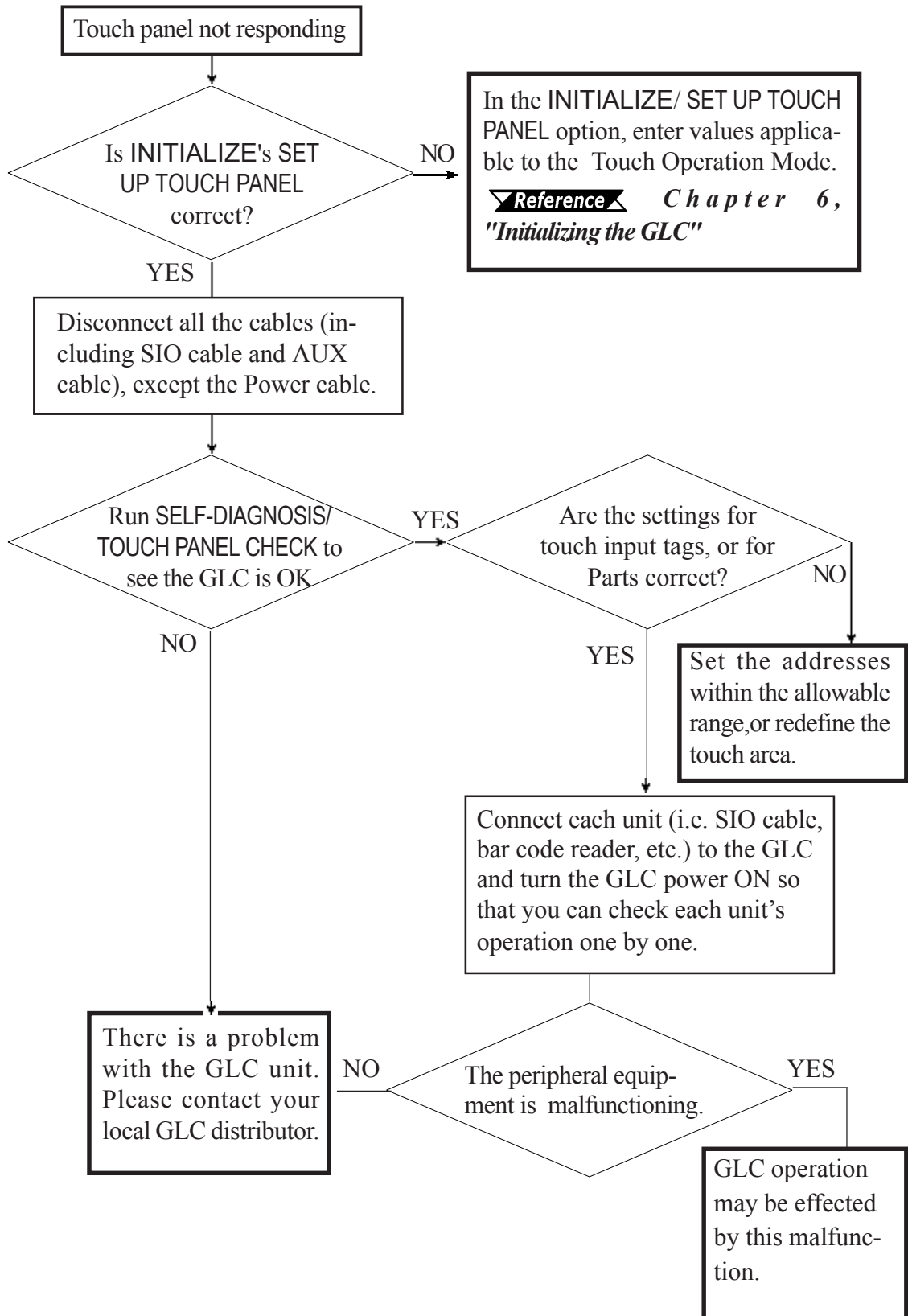

Chapter 7 - RUN Mode and Errors

7.3.5 Cannot Execute Logic Program

Problem	Reason	Solution
Controller Memory's Data Save Area data is not	Battery Problem	Change the battery.
	Memory Problem	Change the memory unit.
Program error	This is a program data transfer error. The data should have been transferred from the data hold area to the RUN area, but it was not	Use Pro-Control to restart the control feature. See Pro-Control User Manual
	When RUN/STOP switchover is performed, the Hold CLEAR feature is enabled.	Turn this feature OFF.
After changing to RUN mode, control returns to STOP mode	A command performance alarm has occurred. Or, a major error has occurred.	Debug the program. Also, check the System variable "#FaultCode".

Chapter 7 - RUN Mode and Errors

7.3.6 Buzzer Sounds when GLC power is turned ON

If you start the GLC unit and the internal buzzer sounds, use the following chart to find the reason and the appropriate solution.

Buzzer Sound	Timing	Reason	Solution
Continuous beep (approx. 1 sec. intervals)	When power to the GP is turned ON	The GP's system program is destroyed.	Send the correct GP system program from the screen creation software to the GP, via the Transfer screen's "Forced Setup" feature.
			Turn on the GP's dip switch #1 (next to CF Card slot) and use the CF Memory Loader Tool to set up the GP.
Two beeps - Repeating (approx. 1 sec. intervals)	When power to the GP is turned ON	A different GP unit's system program has been accidentally installed in this GP.	Send the correct GP system program from the screen creation software to the GP, via the Transfer screen's "Forced Setup" feature.
			At this time an error will appear on the Screen Creation Software's screen, however, simply turn the GP's power supply OFF and then ON, and data transfer will automatically start.
Three beeps - Repeating (approx. 1 sec. intervals)	When the GP's dip switch #1 is turned on (next to CF Card slot) and power to the GP is turned ON.	The CF Card's Memory Loader Tool (MLD****.SYS) file is missing, or destroyed.	Reformat the CF Card and replace the CF Card's Memory Loader Tool file.
	When the GP is started via the Menu Bar's "CF BOOT" key.	The CF Card's Memory Loader Tool (MLD****.SYS) file is missing.	
Three beeps - Repeating (approx. 1 sec. intervals)	When the GP is started via the Menu Bar's "CF BOOT" key.	The CF Card's internal boot program (IPL.SYS) is destroyed.	Reformat the CF Card and replace the CF Card's Memory Loader Tool file.

If the CF Card's boot-up program (IPL.SYS) or the Memory Loader Tool (MLD****.SYS) programs appear to be damaged or destroyed, use the GLC's internal diagnostic program "CF Card Memory Loader File Check" utility to confirm the condition of these files.

Reference *7.2 Self Diagnosis*

7.4 Error Messages

This section explains the messages that appear when an error has occurred in the GLC unit during RUN mode. The problem causing the error message and its related countermeasure are explained in the table below.

After a problem has been solved, unplug the GLC's power cord and then reattach it. *(Only the latest error message will appear on the GLC screen)*

7.4.1 Error Message List

Error Message	Problem	Countermeasure
SYSTEM ERROR (03 : **)	During screen data transfer, an unrecoverable error occurred.	Reference 7.4.2 Error Message Details
SYSTEM ERROR (*** : *** : ***)	During screen data transfer, an unrecoverable error occurred.	Reference 7.4.2 Error Message Details
ILLEGAL ADDRESS IN SCREEN DATA	Settings are used that overlap addresses.	Set the addresses correctly after checking the screen data.
UNSUPPORTED TAG IN SCREEN DATA	The GLC currently in use does not support the desired Tag.	Set the Tag correctly after checking the screen data.
PLC NOT CONNECTED (02 : FF) and (02 : F7)	The communication cable is not connected correctly.	Re-connect the communication cable correctly.
PLC NOT RESPONDING (02 : FE)	PLC's power is not turned ON.	Turn ON the PLC's power.
	GLC unit INITIALIZE settings (Setup I/O, PLC Setting) are incorrect.	Check the INITIALIZE settings and make any necessary corrections.
	The host and GLC Powering up sequence was incorrect.	Turn ON the PLC's power and wait for 2-3 seconds, then turn ON the GLC's power.
	The communication cable is not connected properly.	Check the communication cable and connect it correctly.
RECEIVE DATA ERROR (02 : FD)	The communication cable was disconnected while the GLC was ON.	Turn the GLC OFF and then ON again.
	The GLC is powered OFF, then ON during communication with PLC.	Turn the GLC OFF and then ON again.
	Noise occurred in the communication cable.	Check the communication cable and connect it correctly.
GLC STATION NO. DUPLICATION ERROR (02 : F9)	This GLC's station number is same as another GLC.	Check all GLC station numbers, and set them so they are all unique.
	PLC is powered OFF, then ON during communication with GLC.	Turn the GLC OFF and then ON again.

Chapter 7 - RUN Mode and Errors

NETWORK ADDRESS ERROR (02 : F8)	The SIO address used for this GLC is different from other GLC's. (Only for the Multi-Link connection)	Check all GLC's SIO address settings, and correct any that are incorrect.
PLC COM. ERROR (02 : **)	Specific PLC related error, or an error has occurred with the PLC.	Reference 7.4.2 Error Message Details
SCREEN MEMORY DATA IS CORRUPT (nnnn:mmmm)	ScreenData is corrupted: *nnnn indicates the Screen Number that has an error. *mmmm indicates the number of screens that have errors.(Decimal)	Check the screens that have errors, correct all errors, and then transfer the screen data again.
CLOCK SETUP ERROR *1	The backup battery for the internal clock is running low.	Reference 7.4.2 Error Message Details
SCREEN TRANSFER ERROR	An error occurred in the data transmission from the screen editor to the GLCpanel.	Re-transfer the screen data.
SCREEN TAG LIMIT EXCEEDED	Tags are setup beyond the tag limit (max. of 385.)	Reference 7.4.2 Error Message Details
OBJ. PLC HAS NOT BEEN SETUP (**)	The host PLC set up in the Editor program does not match the PLC in use.	Reference 7.4.2 Error Message Details

Chapter 7 - RUN Mode and Errors

7.4.2 Error Message Details

■ SYSTEM ERRORS

Indicates a fault in the basic operations of the GLC.

Following the error message, an error code, as shown below, will appear. Report the error number and details on how the error developed to your local GLC distributor.

◆ SYSTEM ERROR (03 : x x)

An unrecoverable error occurred during screen data transfer.

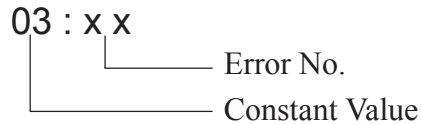

◆ SYSTEM ERROR (x x x : x x x : x x x)

An unrecoverable error occurred during screen data transfer.

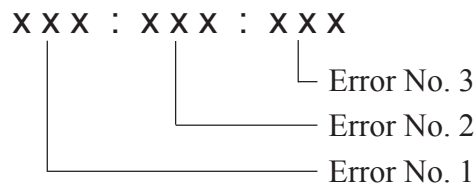

Possible Solutions

- Check if the GLC's Power Cord and the Input signal line have been wired separately from each other.
- Check that the FG line has been grounded correctly, according to your country's standards.
- Re-send the screen data from the PC to the GLC.
- If other types of communication errors, such as [RECIEVE DATA ERROR], [PLC COM. ERROR], have also occurred, try to correct those problems also.

▼ **Reference** ▲ 7.4.1 Error Message List

If the above mentioned methods do not solve the problem, please contact your local GLC distributor.

◆ When the GLC changes to OFFLINE mode during RUN mode

When the GLC changes to OFFLINE mode without the user first pressing the screen, there is a possibility that the screen data has been damaged. In this case, after the SYSTEM ERROR displays, the screen automatically reverts to OFFLINE mode after about 10 seconds. Run the INITIALIZE MEMORY command and transfer the GLC screen data again from your PC.

In most cases, system errors are related to the problems mentioned below.

Environment Related Problems

If an error occurs which has no apparent connection to the GLC's current operation, the error may be due to the condition of GLC's operating environment. This can include noise or electrostatic interference in the power code or the communication line. In this case you need to check if the power code and the communication line wiring and FG grounding are correct.

Screen Data or Project Data Related Problems

If an error seems to be caused by a particular GLC operation, the error may be related to the screen or project data transferred to the GLC. In this case, try sending screen data via the FORCE SYSTEM SETUP feature, which will transfer both the screen data and the project data to the GLC.

▼Reference *For details about the FORCE SYSTEM SETUP feature, refer to **GLC-PRO/PBIII for Windows Operation Manual, Transfer Settings section.***

GLC Unit Related Problems

If disconnecting and then re-connecting the power code corrects an error, the problem may not be related to the GLC unit itself. However, to identify if the GLC unit has any problems, run the OFFLINE mode's SELF-DIAGNOSIS program.

Peripheral Equipment Related Problems

(When the GLC is equipped with a printer I/F)

If an error occurs only during printout, there may be a problem with the printer. Check the printer cable wiring and the FG line as well as the printer itself.

When a communication error occurs continuously

(When using the Direct Access method)

If a communication error occurs continuously, the GLC may define the error as a system error. In this case you need to solve the problem causing the original communication error.

Chapter 7 - RUN Mode and Errors

■ ILLEGAL ADDRESS IN SCREEN DATA

Caused by an overlap of addresses.

After the error message, error codes, as listed below will appear. If the error cannot be fixed, please report the error code and details on how the error developed to your local GLC distributor.

ILLEGAL ADDRESS IN SCREEN AREA (00B:XXX:XXX)

Error No. 1
Error No. 2
(Refer to Table below)

Overlapping Addresses

Error 1	Error 2	Meaning
0C1	191	All or part of the T-tag ^{*1} or S-tag address range overlap the addresses of System Data Area.
	192	
	193	
0C2	194	All or part of the System Data Area address, A-tag, or S-tag address range overlap the addresses setup in a T-tag. ^{*1}
	195	
	196	
0C3	197	All or part of a T-tag ^{*1} , S-tag or K-tag address range overlap the address range set in an A-tag (Alarm Message.)
	198	
	199	
0C9	19B	All or part of a T-tag ^{*1} , S-tag or K-tag address range overlap the address range set in an A-tag (Log alarm.)



Note: Overlapping addresses, other than the ones mentioned above, can also cause the Illegal Address message.

E.g. When the starting address of the System Data Area is set to 100, and the tag below is setup:

Tag Name/ Part ID No.	Word Address	Tag Format
N1	99	BCD32

Starting from addresses 99, two(2) words are used, which causes it to overlap address 100.

^{*1} For details about the T-tag (trend graph) and A-tag (alarm messages),

Reference *GLC-PRO/PBIII for Windows Tag Reference Manual (included with the screen creation software)*

■ PLC COM. ERROR

Appears when the address setup for tags exceeds the address range used in the host (PLC.) Check the Error Number that appears and use the following table to solve the problem.

PLC COM. ERROR (02 : x x)

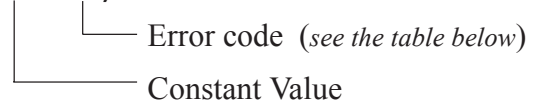

Error #	Problem	Countermeasure
FC	The communication settings for this unit and the host do not match.	Change the SIO communication settings to match the host's.
FB	The address set on a tag, the address used for storing data for Trend graph, or the address set by an alarm message is out of a set range. * Memory to Memory Link type. * Siemen's PLC Series.	* When using Memory Link type: Set the addresses within the set range of the System Data Area (0 to 2047), and re-send correct data. * When using a Toyoda Machine Works PLC: Set the addresses within the set range of the devices. * When using a Yaskawa PLC: Set the addresses within the set range of the devices.
FA	Address range error	Set the addresses within the allowable range.
53	When using a Matsushita Electronics PLC, and there are too many screen tags, the PLC will not receive data.	Decrease the number of tags on the screen.
51	The tag addresses, Trend graph data storage address, Alarm message Registry address, do not exist in the PLC's internal memory.	* When using a Fuji Electric PLC: Setup the addresses in a device range that exists.
Others	The Error code for each PLC can be found in the table on the last page of this chapter. Then, look up the Error Number in the indicated PLC manual. Or, report the Error Number to the PLC manufacturer.	



Note: In Hitachi's HIDIC H (HIZAC H) Series, the error code is divided into 2 bytes, whereas the GLC Error Number is composed of 1 byte codes.

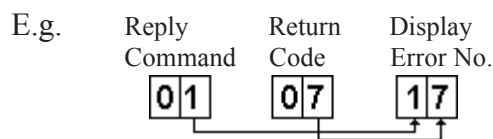

When the Display Error Number is 8*, or 5*, use only the left column as the error number.

Chapter 7 - RUN Mode and Errors



- In Toshiba's PROSEC T Series, the Error Code is 4 characters long; on the GLC, Error Numbers are changed to and displayed in Hexadecimal.
- With the Allen-Bradley PLC-5 and SLC-500 Series, the EXT/STS error codes have been re-mapped to start at D0 HEX, so they will not conflict with other error codes. When looking up the error number in the PLC manual, subtract D0 h from the GLC error code to find its error value.

E.g.	GLC Error Code	—>	PLC Error Code
	D1	—>	01
	EA	—>	1A

■ CLOCK SET UP ERROR

This message displays when the lithium backup battery's voltage for the internal clock runs low. To reset the error, you need to turn the GLC's power OFF and then ON again. Leave the GLC ON continuously and the battery's charge will become sufficient for backup after 24 hours, and will be fully charged in approximately 96 hours. If the battery is incorrectly replaced, the battery may explode. To avoid the danger, please do not replace the battery yourself. When the battery needs a replacement, please consult with your local GLC distributor.

After changing the backup battery, set up the internal clock.

Reference Chapter 6 - Initializing the GLC

The lifetime of the backup battery depends on the ambient temperature and the amount of current being charged and used. The table below gives a general indication of how long the battery will last.

Battery Temperature	40°C or lower	50°C or lower	60°C or lower
Expected Lifetime	10 years or longer	4.1 years or longer	1.5 years or longer

■ SCREEN TAG LIMIT EXCEEDED (max. of 384)

When tags are setup beyond the tag limit, all tags in excess of number 384 will be disabled. Plus, when tags involve registered Windows and loaded screens, they are disabled in this order: Window Registry, Load Screen.

1. Disabled registered windows start from the last screen used.
2. Disabled loaded screens start from the last screen used.

To correct this problem, reduce the number of tags to within the allowed limit.

■ OBJ. PLC HAS NOT BEEN SETUP

The host PLC setup in the Editor program (i.e. the .prw file) does not match the PLC in use. Use the Error Code that follows the error message to select the proper PLC type and correct the GLC's INITIALIZE setup data so that it matches this.

OBJ. PLC HAS NOT BEEN SETUP (X X)

|
The PLC number (*Hexadecimal*)
written to the GLC's System File

Chapter

8 Maintenance

1. Regular Cleaning
2. Periodic Check Points
3. Changing the Backlight

8.1 Regular Cleaning

8.1.1 Cleaning the Display

When the surface or the frame of the display gets dirty, soak a soft cloth in water with a neutral detergent, wring the cloth tightly, and wipe the display.



- Do not use paint thinner, organic solvents, or a strong acid compound to clean the unit.
- Do not use hard or pointed objects to operate the touch-screen panel, since it can damage the panel surface.

8.1.2 Installation Gasket Check/Replacement

The installation gasket protects the GLC and improves its water resistance. For instructions on installing the GLC's gasket, refer to

Reference *Chapter 3 "Installation and Wiring"*



A gasket which has been used for a long period of time may have scratches or dirt on it, and could have lost much of its water resistance. Be sure to change the gasket at least once a year, or when scratches or dirt become visible.

■ Installation Gasket Attachment Procedure (all units)

1) Place the GLC on a flat, level surface facing the display face downwards.

2) Remove the gasket from the GLC.



Chapter 8 - Maintenance

- 3) Attach the new gasket to the GLC.
Be sure to insert the gasket into the GLC's groove so that the gasket's groove sides are vertical.

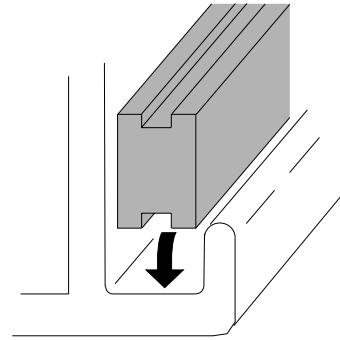

- 4) Check if the gasket is attached to the GLC correctly.



- ***The gasket must be inserted correctly into the groove for the GLC's moisture resistance to be equivalent to IP65f.***
- ***The upper surface of the gasket should protrude approximately 2mm out from the groove. Be sure to check that the gasket is correctly inserted before installing the GLC into a panel.***

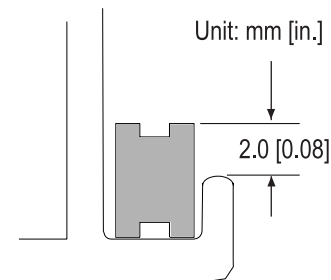

8.2 Periodic Check Points

To keep your GLC unit in its best condition, please inspect the following points periodically.

GLC Operation Environment

- Is the operating temperature within the allowable range (0°C to 50°C)?
- Is the operating humidity within the specified range (10%RH to 90%RH, dry bulb temperature of 39°C or less)?
- Is the operating atmosphere free of corrosive gasses?

Electrical Specifications

- Is the input voltage appropriate? GLC-2400T: DC19.2V to DC28.8V

Related Items

- Are all power cords and cables connected properly? Have any become loose?
- Are all mounting brackets holding the unit securely?
- Are there many scratches or traces of dirt on the installation gasket?

8.3 Replacing the Backlight

When the unit’s backlight burns out, the unit’s status LED will turn orange. If the OFFLINE menu’s “USE TOUCHPANEL AFTER BACKLIGHT BURNS OUT” feature is set to “NO”, the GLC’s touch panel will be disabled. *1

Reference 6.4.3 SET UP TOUCH PANEL

GLC2400 Series units use a CFL, long-life type backlight. The actual life of the backlight however, will vary depending on the GLC’s operating conditions, and replacement may be required. A GLC2400 Series backlight has a life of 50,000 hours (approx. 5.7 years, at 25°C and 24 hour operation), when the backlight is lit continuously (time required for brightness to fall to half its normal level.)



WARNINGS

- To prevent an electric shock, be sure the GLC’s power cord is unplugged from the power outlet prior to replacing the backlight.
- When the power has just been turned OFF, the unit and backlight are still very hot. Be sure to use gloves to prevent burns.
- The backlight is very fragile. Do not touch the glass tube directly or try to remove its power cord. If the glass tube breaks you may be injured.



Note: Use the following table to check that you have ordered the correct backlight.

GLC Model	Backlight Model
GLC2400-TC41-24V	PS400-BU00-MS

For backlight replacement details, refer to the replacement backlight unit’s installation guide.

*1 If “NO” has been selected for the OFFLINE menu’s “FORCE RESET” feature, Touch-Panel operation is disabled.

Reference 6.4.3 SET UP TOUCH PANEL

Index

A

ACCESS lamp 9, 3-10
 aerospace equipment 6
 ALARM MESSAGE 5-26
 Available Software 1-4, 1-5, 1-9

B

Backlight Burnout Detection Feature 1-7
 BRIGHTNESS SETTING 5-13

C

CAUTIONS 3-8, 3-10
 CF Card 3-10
 CF Card ACCESS switch OFF 9, 3-10
 CF Memory Loader Feature 1-7
 Changing the Backlight 7-4
 CHARACTER STRING DATA Mode List 5-7
 CHARACTER STRING DATA SETUP 5-7
 Cleaning the Display 7-1
 COMMUNICATION INTERFACE 5-10
 COMMUNICATION RATE 5-10
 COMMUNICATION SETUP 5-14
 Connecting the GP's Power Cord 3-6, 3-7, 3-12, 3-13
 CONTRAST SETTING 5-13
 CONTROL 5-10
 Copyright 1
 Creating installation openings 3-2
 crime prevention devices 6
 CUSTOMIZE SETUP (n:1) 5-18, 5-21, 5-22, 5-23, 5-24

D

DATA FORMAT 5-6
 DATA LENGTH 5-10
 DATA TYPE OF SCREEN NO. 5-4
 Display Features 2-3
 Display Panel 2-9
 DISPLAY PATTERN 6-11

E

Electrical Specifications 2-1
 Environmental Specifications 2-1
 Error Message Details 6-17
 Error Message List 6-15
 Error Messages 6-15
 errors or omissions 1
 Ethernet Feature 1-7
 Expansion Interface 2-9

F

failsafe system design 6
 Features and Performance 2-3
 FRAME BUFFER 6-12

G

GLOBAL WINDOW 5-6
 GLOBAL WINDOW ACCESS 5-6
 GLOBAL WINDOW SETUP 5-6
 GP data 3-10
 GP Disposal Precautions 9
 GP SELF-DIAGNOSIS Item List 6-10
 GP Start-up and Maintenance Precautions 8
 GP TOUCH MONOPOLIZE 5-19
 GP's Display Panel 11
 GP-377R Series Models 12
 Graphic Panel Dimensions 2-11
 Grounding the GP 3-8

H

High quality fonts (32 dot) 1-7

I

ILLEGAL ADDRESS IN SCREEN DATA 6-19
 INITIAL SCREEN NO. 5-26
 Initialization Items 5-2
 Initialization Screen 5-1
 INITIALIZE INTERNAL MEMORY 5-24
 INITIALIZE MEMORY 5-2
 Installation 3-1, 3-9, 3-10

Index

Installation Fasteners 2-12
Installation Precautions 8
Interface Specifications 2-6
INTERNAL FEPROM CHECKSUM (System & Protocol) 6-11, 6-12
IP65f 12

M

medical devices 6
Mitsubishi MELSEC-AnA Series PLC 1
Moisture Resistant Gasket 3-1
Moisture Resistant Gasket Replacement 3-1, 7-1
moisture resistant seal 3-1
MONOPOLIZE TIME (0 to 2550s) 5-19

N

NETWORK INFORMATION (DEV/ADR) 5-16
No Display 6-3
No GP/HOST Communication 6-3
No GP/Host Communication 6-7
nuclear power control devices 6

O

OBJ. PLC HAS NOT BEEN SETUP 6-20
OFFLINE displays During RUN Mode 6-3
ONLINE ERror Display 5-26
Optional Maintenance Items 1-6
Options 1-5, 1-6
Overlapping Addresses 6-19

P

PARITY 5-10
PASSWORD SETUP(0-9999) 5-3
Periodic Check Points 7-3
Placement of I/O Signal Lines 3-8
PLC PRIORITY 5-18
PLC SETUP 5-15
Possible Types of Trouble 6-3
Power Input Terminal Block 2-9
Prevent Damage to the GP 10

R

REGISTRATION NO. (1-256) 5-6
Regular Cleaning 7-1
RESET GP ON WRITE ERROR 5-15

RETRY COUNT 5-14
RUN Mode 6-1

S

SELF-DIAGNOSIS - Details 6-11
Safety Symbols and Terms 1-7
Safty Precautions 6, 12
Screen Data or Project Data Related Problems 6-18
SCREEN TAG LIMIT EXCEEDED (max. of 384) 6-21
SELF-DIAGNOSIS 6-10
SELF-DIAGNOSIS-tandard Operation 4-6
Serial Interface 1-4, 2-6, 2-9
SET UP I/O 5-10
SET UP SCREEN 5-2, 5-26
SET UP TIME 5-2, 5-25
SET UP TOUCH PANEL 5-12
SIO CHECK 6-13
Sound Output I/F 1-7
STAND-BY MODE TIME (0-255) 5-3
START TIME (0-255) 5-3
STATION NO. (0-15) 5-17
Status LED 2-9
Steps to run SYSTEM RESET 5-12
Structural Specifications 2-2
SYSTEM AREA READ SIZE (0-256) 5-15
SYSTEM AREA SETUP 5-4
System Area Size 5-4
SYSTEM AREA START (DEV/ ADR) 5-15
SYSTEM ENVIRONMENT SETUP 5-2, 5-3
SYSTEM RESET MODE 5-12
SYSTEM SETUP 5-3

T

TOOL CONNECTOR 6-12
Tool Connector 1-4, 2-9, 3-9, 3-10
TOUCH BUZZER SOUND 5-3
TOUCH OPERATION MODE 5-12
TOUCH PANEL 6-11
Touch Panel 2-9
Touch Panel / Clock Accuracy 2-4, 2-5
Touch Panel Does Not Respond 6-3, 6-9
transportation vehicles 6
Troubleshooting 6-3
Troubleshooting Checklists 6-4

Turning the GP's Power ON 4-1

U

USE TOUCH PANEL AFTER BACKLIGHT BURN-
OUT 5-13

V

Validation List 5-17

W

WARNINGS 3-6, 3-9, 7-4

WINDOW LOCATION 5-6

Wiring Cautions 3-6, 3-12

Wiring Precautions 8

Memo