

# Pro-face

Human Machine Interface



Graphic Logic Controller



- TYPE A1
- TYPE A2
- TYPE B+
- TYPE B
- TYPE C
- TYPE H1
- TYPE H2

**LT Series Models**  
 Satisfying Your Need  
 for Flexible Factory Control

I/O Control-Equipped Operator Interfaces

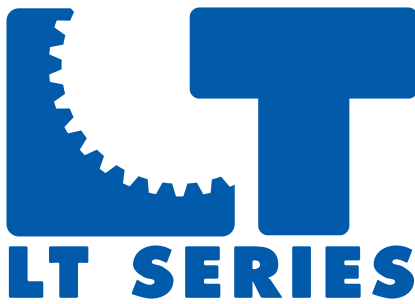

ISO 9001  
JQA-1367



# Control Takes on a Whole New Form



Pro-face's LT Series models combine control, operation and display functions into a single, easy-to-view, low-cost controller. No more need for expensive, complex, bulky production control systems. The LT's built-in controller brings multifunctional, high-quality control to a wide range of systems, such as the processing, textile, printing, parts assembly, agriculture and maritime applications. LT Series of products opens up an entirely new field in factory automation and lets you build safer, more accurate production systems.



All-in-One unit for Control, Operation and Display

Which means...

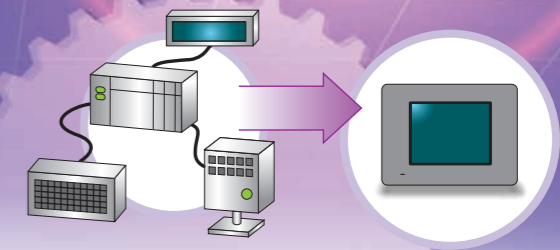

Graphical display and Touch Operation!

Easy-to-read graphic display and convenient touch-sensitive screen.

Less wiring and less space!

Connection is simple, and the control panel is compact.

Frees up space around the control panel!

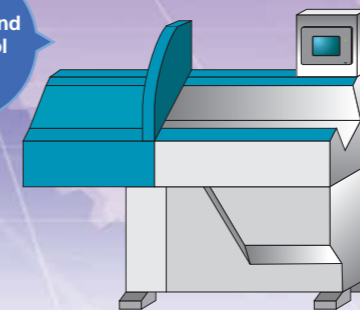

Simple wiring means easier maintenance too.

Software advantages!

Dynamic linkage between HMI and control.

Pro-face's combined HMI and control software is easy to use.



## NEW LT Color Now Available!

The new LT color display is easier to see than monochrome monitors, making it easier to monitor status in the workplace and improving control of the production floor.

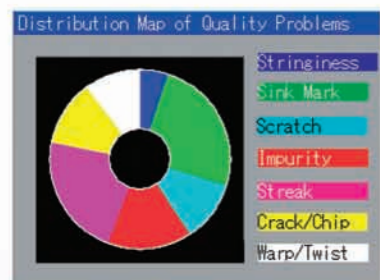

Improves visibility by color-coding graphics and text.

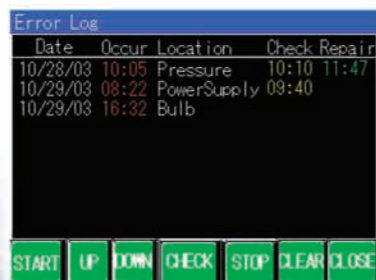

Makes warnings and alarms easier to understand.

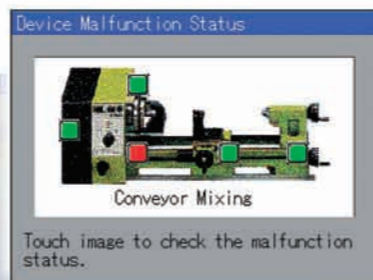

Enables instant device status Verification with BMP image display



\* Built-To-Order product. Please contact your local Pro-face distributor.



Screen Editor and Logic Program Development Software

## GP-PRO/PBIII -C- Package03 LT Design Software

# GP-PRO/PBIII -C- Package03

Easy Screen Creation

Easy Logic Programming

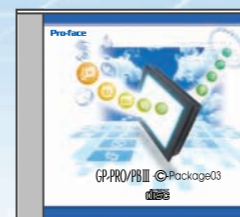

- Supports Ladder Monitor
- Variety of Ladder Instructions
- Expanded Alarm Summary
- Improved Keypad Display Function
- Various graphic types Available

Data created with LT Editor can also be used.

# Our complete lineup matches your needs

5.7  
inch  
64 COLORS  
STN LCD

64Colors STN LCD

**TYPE A1**



Sink output

P.O5

**TYPE B+**



Sink output

P.O5

**TYPE H1**



Sink output

P.O7

Item	Type A	Type B+	Type H		
			A D	ADT	ADP
DC24V Input Points	16	16	16	16	16
DC24V Output Points	16	16	16	16	16
Analog Input (ch)	—	*1	2	2	2
Analog Output (ch)	—	*1	1	2	2
High-speed Counter	—	*1	4 <sup>2</sup>	4 <sup>2</sup>	4 <sup>2</sup>
Pulse Output	—	*1	4 <sup>3</sup>	4 <sup>3</sup>	4 <sup>3</sup>
Thermocouple(J/K) Temperature Input	—	—	—	3	—
PT100 Temperature Input	—	—	—	—	2
Remote I/O (Flex Network)	—	○	—	—	—

\*1 Compatible with Flex Network units.  
 \*2 Shared with DC24V input.  
 \*3 Shared with DC24V output.

5.7  
inch  
BLUE mode  
LCD

BLUE Monochrome LCD

**TYPE A1**



Sink output

P.O5

**TYPE A2**



Source output

P.O5

**TYPE B+**



Sink output

P.O6

**TYPE B**



Sink output

P.O6

**TYPE C**



Sink output

P.O6

**TYPE H1**



Sink output

P.O7

**TYPE H2**



Source output

P.O7

Item	Type A	Type B+	Type B	Type C	Type H		
					A D	ADT	ADP
DC24V Input Points	16	16	—	—	16	16	16
DC24V Output Points	16	16	—	—	16	16	16
Analog Input (ch)	—	*1	*1	*1	2	2	2
Analog Output (ch)	—	*1	*1	*1	1	2	2
High-speed Counter	—	*1	*1	*1	4 <sup>2</sup>	4 <sup>2</sup>	4 <sup>2</sup>
Pulse Output	—	*1	*1	*1	4 <sup>3</sup>	4 <sup>3</sup>	4 <sup>3</sup>
Thermocouple(J/K) Temperature Input	—	—	—	—	—	3	—
PT100 Temperature Input	—	—	—	—	—	—	2
Remote I/O (Flex Network)	—	○	○	○	—	—	—
SIO	—	—	—	○	—	—	—

\*1 Compatible with Flex Network units.  
 \*2 Shared with DC24V input.  
 \*3 Shared with DC24V output.

## Specifications (Common to All Models)



### Functional Specifications

Item	ColorType			Blue(Monochrome)Type				
	Type A	Type B+	Type H	Type A	Type B+	Type B	Type C	Type H
Model	A1 (Sink Output Type) GLC150-SC41-XY32K-24V	GLC150-SC41-XY32K-24V	H1 (Sink Output Type) GLC150-SC41-AD*K-24V H2 (Source Output Type) GLC150-SC41-ADPC-24V	A1 (Sink Output Type) GLC150-BG41-XY32K-24V A2 (Source Output Type) GLC150-BG41-XY32K-24V	GLC150-BG41-XY32K-24V	GLC150-BG41-FLEX-24V	GLC150-BG41-RSFL-24V	H1 (Sink Output Type) GLC150-BG41-AD*K-24V H2 (Source Output Type) GLC150-BG41-AD*C-24V
Display Type	STN Color LCD			monochrome LCD				
Resolution	320 x 240 pixels			320 x 240 pixels				
Nominal Display Area	W118.2mm(4.65in) x H89.4mm(3.52in)			W115.2mm(4.54in) x H86.4mm(3.40in)				
Color, Gradation	64 colors			Blue / White				
Backlight	CFL (lifespan: more than 36,000 hours when continuously lit)			CFL (lifespan: more than 25,000 hours when continuously lit)				
Contrast Control	8 levels via touch panel							
Language Fonts	ASCII: (Code Page 850) Alphanumeric (including European fonts), Chinese: (GB2321-80 codes) simplified Chinese fonts, Japanese: ANK 158 type, Kanji: 6962 types (includes non-kanji: 607, and Standard JIS Type 1 and 2), Korean: (KSC5601-1992 codes) Hangul fonts, Taiwanese: (Big 5 codes) traditional Chinese fonts							
Text	Display Sizes <sup>*1</sup>	8 x 8, 8 x 16, 16 x 16, 32 x 32 dots						
	Font Sizes	Both height and width can be expanded 1, 2, 4, or 8 times						
	8 x 8 Dots	40 char. x 30 rows						
	8 x 16 Dots	40 char. x 15 rows						
	16 x 16 Dots	20 char. x 15 rows						
Displayable Characters	32 x 32 Dots	10 char. x 7 rows						
	Application	1MB FLASH EPROM (approx. 320 screens at 3.2KB/screen)						
	Data Backup	96KB SRAM (uses lithium battery <sup>*2</sup> )						
Control Memory	Variable Data Area	32KB SRAM (uses lithium battery <sup>*2</sup> )						
	Program Area	128KB FLASH EPROM						
	Touch Panel	16 x 12 keys/screen (1 or 2 point touch)						
Clock Accuracy	±65 seconds/month (at room temperature)							

\*1 The font used varies depending on the language and font size selected.  
 \*2 A lithium battery's lifetime is 10 years when the battery's ambient temperature is under 40 degrees centigrade, 4.1 years when the battery's ambient temperature is under 50 degrees centigrade, and 1.5 years when the battery's ambient temperature is under 60 degrees centigrade. When used for backup, the lifetime is approximately 60 days with a fully charged battery, and approximately 6 days with a half-charged battery.

### General Specifications

Item	Color Type			Blue(Monochrome)Type				
	Type A	Type B+	Type H	Type A	Type B+	Type B	Type C	Type H
Electrical	Input Voltage	DC24V						
	Rated Voltage	DC20.4V to DC28.8V						
	Allowable Voltage Drop	10 ms or less						
	Power Consumption	20W or less						
	In-Rush Current	30A or less						
	Voltage Endurance	AC1000V at 10mA for 1 minute (between charging and FG terminals)						
	Insulation Resistance	Above 20MΩ at DC500V (between charging and FG terminals)						
	Operating Temperature (Panel Interior and Panel Face) <sup>*1</sup>	0°C to 50°C						
	Storage Temperature	-20°C to +60°C						
	Operating Humidity	10% RH to 90% RH (no condensation, wet bulb temperature: 39°C or less)						
Environmental	Storage Humidity	10% RH to 90% RH (no condensation, wet bulb temperature: 39°C or less)						
	Air Purity (Dust)	0.1mg/m <sup>3</sup> or less (non-conductive levels)						
	Corrosive Gases	Free of corrosive gases						
	Atmospheric Endurance (Operation Altitude)	800hPa to 1,114hPa (2,000 meters or lower)						
	Vibration Resistance	IEC61131-2 (JIS B 3502) compliant When vibration is NOT continuous: 10Hz to 57Hz 0.075mm, 57Hz to 150Hz 9.8m/s <sup>2</sup> When vibration is continuous: 10Hz to 57Hz 0.035mm, 57Hz to 150Hz 4.9m/s <sup>2</sup> X, Y, Z directions for 10 times (80min)						
	Noise Immunity (via noise simulator)	Noise voltage: 1500Vp-p <sup>2</sup> , Pulse Duration: 1μs, Arise time: 1ns						
	Electrostatic Discharge Immunity	Contact discharge of 6kV (IEC 61000-4-2 Level 3)						
	Certifications	CE Marking (EN55011 class A, EN61000-6-2), UL / C-UL (UL 508, UL1604)						
	Grounding	100Ω or less, or your country's applicable standard						
	Rating <sup>*3</sup>	Equivalent to IP65f (JEM 1030), and NEMA#250 TYPE4X/12						
Structural	External Dimensions	W207mm(8.15in) x H157mm(6.18in) x D75.8mm(2.98in)						
	Weight	1.5kg (3.3lb) or less						
	Cooling Method	Natural air circulation						

\*1 Ensure that the temperatures both at the display surface and inside the panel are within the prescribed ambient temperature range during use. Use at temperatures outside this range may lead to malfunction.  
 \*2 1000 Vp-p for pulse output and PWM output functions.  
 \*3 Limited to the front face after installation in a panel. Testing equivalent to IP65f conditions has been performed; however, performance cannot be guaranteed for every type of environment.  
 If the product is subjected to an oil mist over an extended period of time, even when using the oil designated in the tests, or if the product is subjected to an extremely low-viscosity cutting oil, some oil penetration may result due to peeling of the front sheet. If this occurs, a countermeasure is required. Similar penetration, or plastic deformation, may also occur with oils other than those designated. Confirm operation environment prior to installation. Furthermore, rubber gaskets that have been used for extended periods of time, and those that have been scratched or soiled after installation, may not provide sufficient protection. It is recommended that the rubber gasket be replaced periodically to guarantee consistent protection.

### External Dimensions

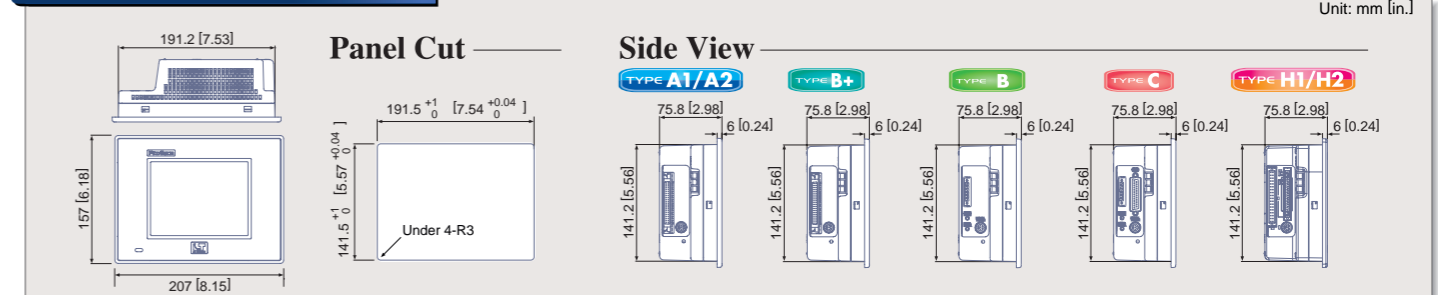

## TYPE A1 TYPE A2 Integrates easily into compact equipment

16 input points and 16 output points make for easy integration into your current system

TYPE A1 Built-in DIO (Sink output) Type TYPE A2 Built-in DIO (Source output) Type

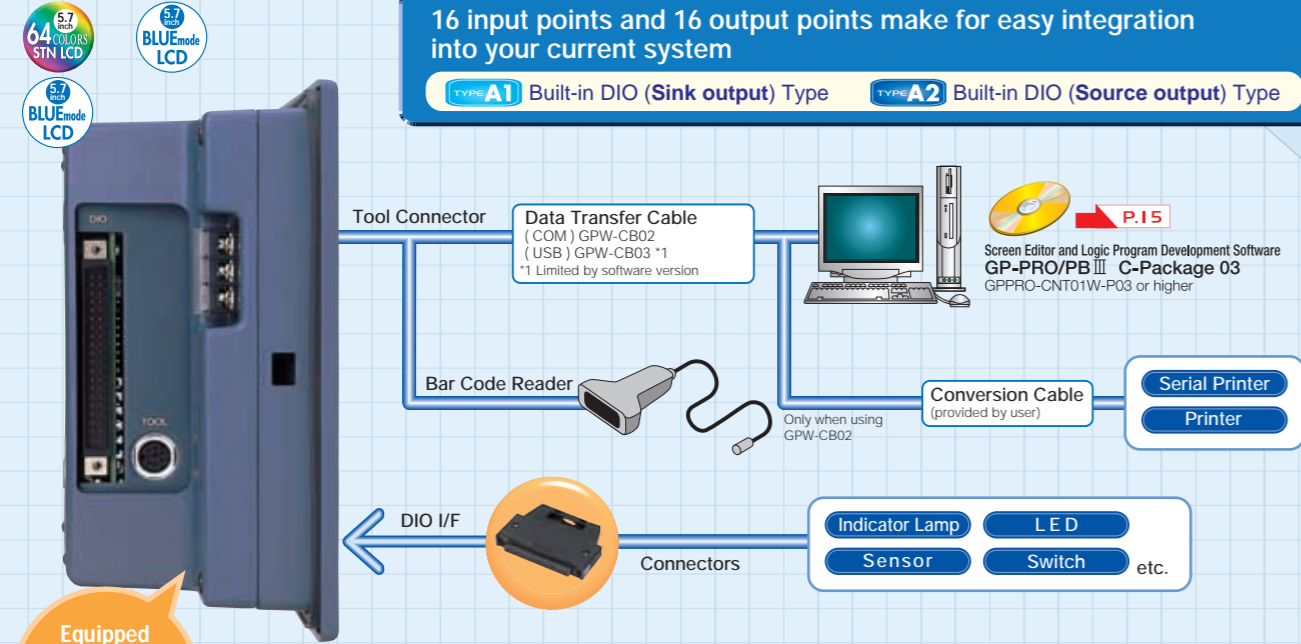

Equipped with DC24V 32-point input/output

### Things to remember when comparing I/O points!

	PLC with 50 I/O points	LT Series (Type A/B+) with 32 I/O points
I/O points used for panel operation and display	12 input points *1 9 output points *2	Built-in graphic display and touch panel replace switches and lamps.
I/O points used for equipment control	29 points available	32 points available <b>All available for device control!</b>

\*1 Used for switches, such as manual/auto (2 points), auto start, stop, stop, buzzer, alarm reset, jog forward, jog backward, raise, lower, continuous operation, and material replenishment complete.  
\*2 Used for lamps indicating auto operation, motor overload, error, lower error, stop error, pneumatic error, material jam, and no material.

## TYPE B+ Extend your system with two types of built-in I/O

Further expand your Remote I/O (Flex Network) system with built-in 32-point DIO

TYPE B+ Built-in Remote I/O (Flex Network)

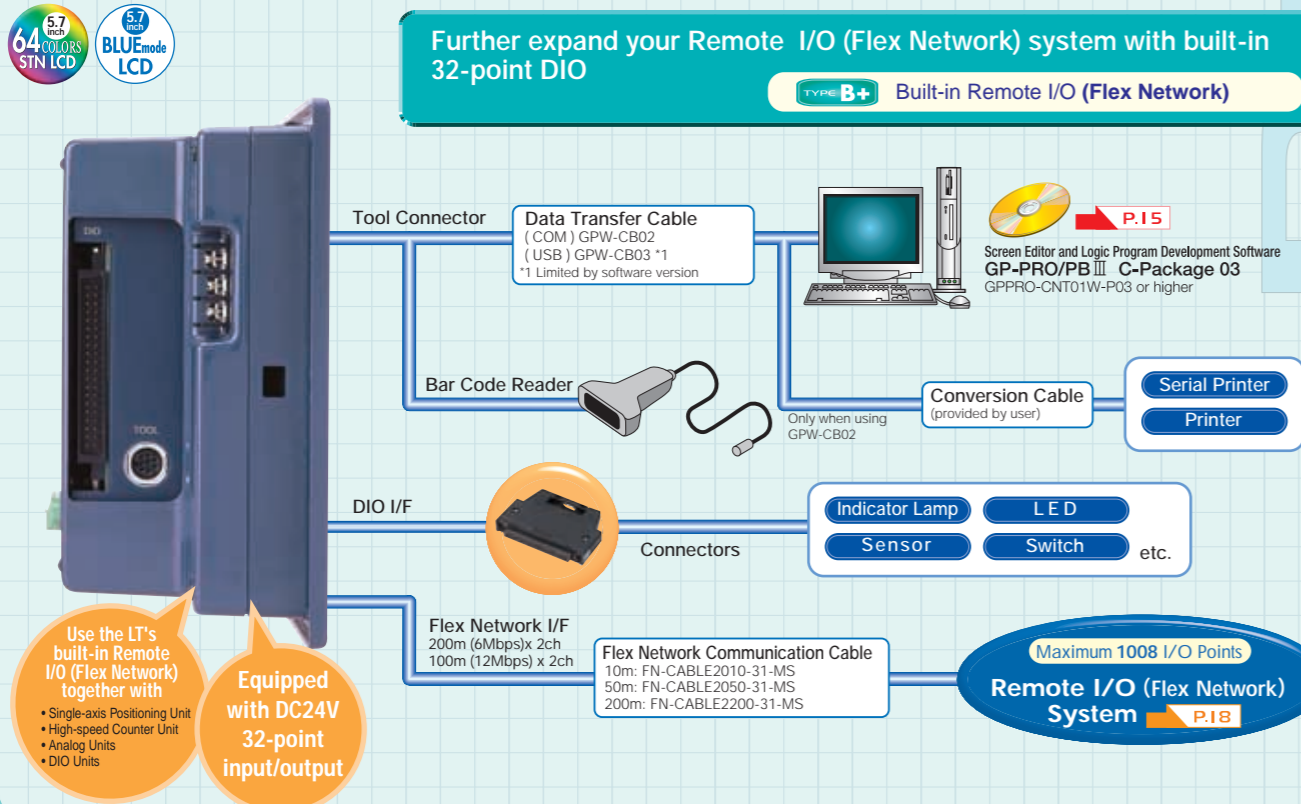

Use the LT's built-in Remote I/O (Flex Network) together with

- Single-axis Positioning Unit
- High-speed Counter Unit
- Analog Units
- DIO Units

Equipped with DC24V 32-point input/output

## TYPE B Reduces wiring and expands system scalability

Use Flex Network to connect up to 1008 points (63 nodes) over a maximum of 400m (with 6Mbps, 200m x 2 ch).

TYPE B Built-in Remote I/O (Flex Network)

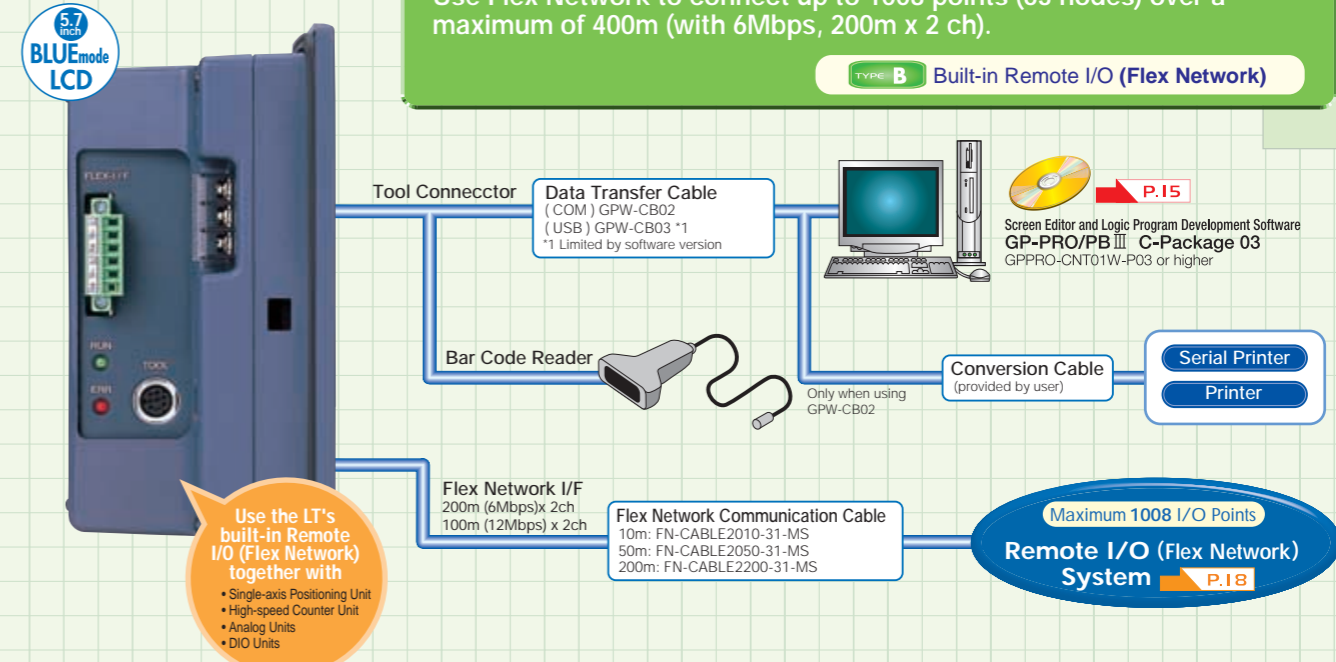

Use the LT's built-in Remote I/O (Flex Network) together with

- Single-axis Positioning Unit
- High-speed Counter Unit
- Analog Units
- DIO Units

## TYPE C Connect to temperature controllers, inverters, PCs and single-board controllers

Further expansion with the SIO I/F, in addition to the Remote I/O (Flex Network)

TYPE C Built-in SIO + Remote I/O (Flex Network)

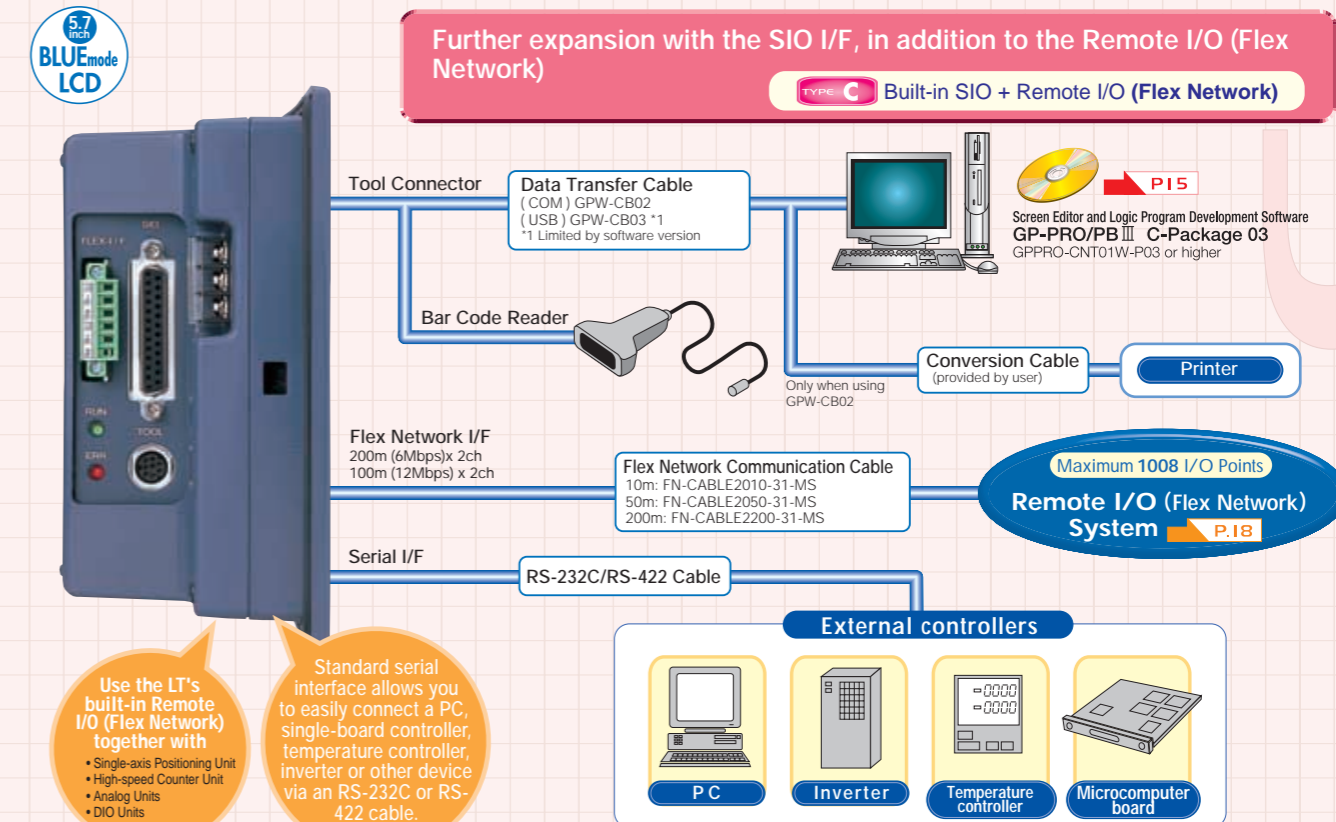

Use the LT's built-in Remote I/O (Flex Network) together with

- Single-axis Positioning Unit
- High-speed Counter Unit
- Analog Units
- DIO Units

Standard serial interface allows you to easily connect a PC, single-board controller, temperature controller, inverter or other device via an RS-232C or RS-422 cable.



# Comes equipped with analog I/O, temperature input and pulse output

- Easily...**
- Control pressure and flow
  - Set positioning
  - Monitor temperature, etc.
- TYPE H-AD** Built-in 32-point DIO + 2-point AD/1-point DA
- TYPE H-ADT** Built-in 32-point DIO + 2-point AD/2-point DA +3-point Thermocouple Input
- TYPE H-ADP** Built-in 32-point DIO + 2-point AD/2-point DA +2-point Pt100 Input
- TYPE H1 : Sink Type    TYPE H2 : Source Type

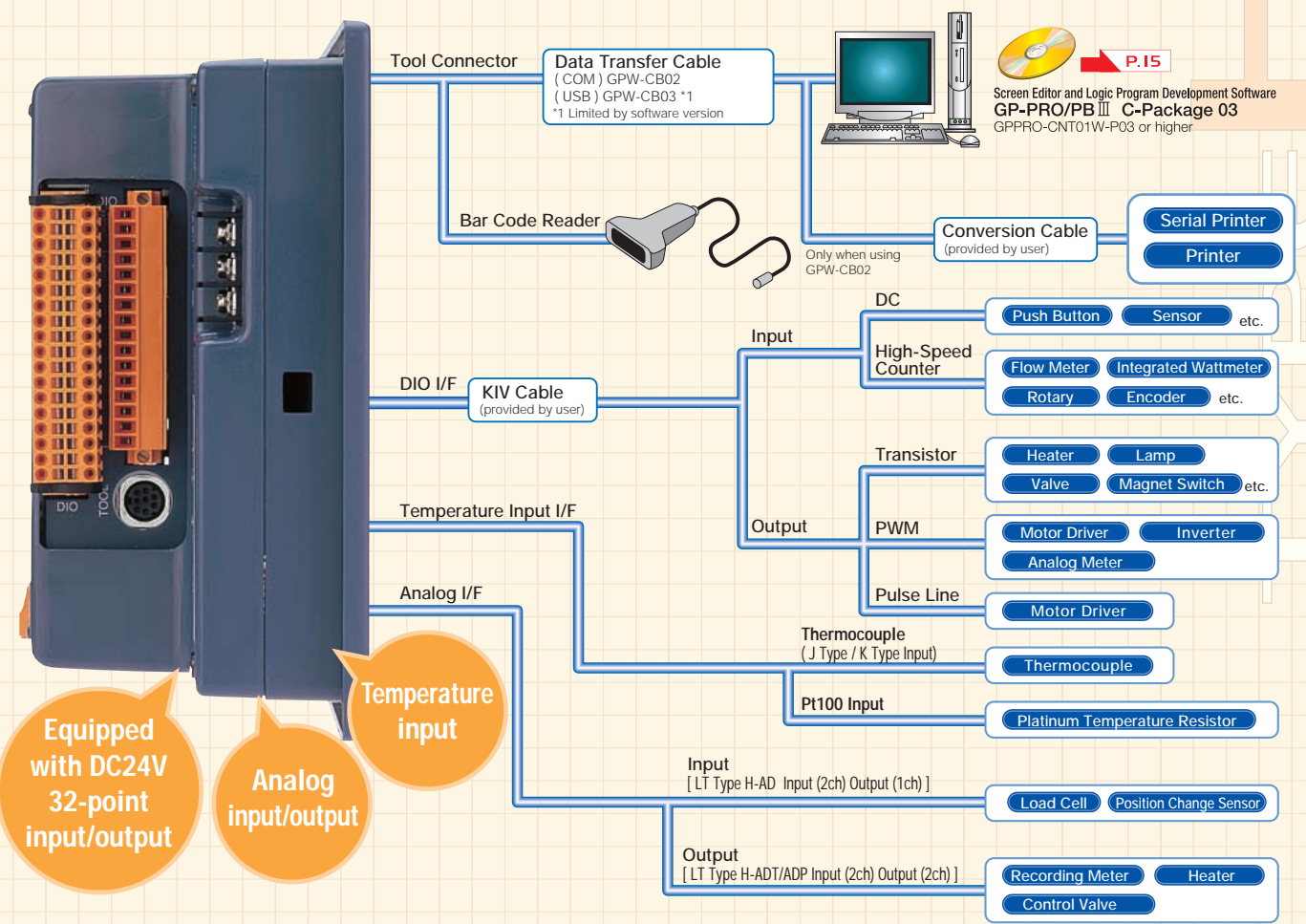

Equipped with DC24V 32-point input/output

Analog input/output

Temperature input

### Choose from 3 types to better match your needs!

Function	Type H-AD	Type H-ADT	Type H-ADP
DC24V 16 Input Points (10kpps 16-bit high speed counter x 4 points possible. *1)	○	○	○
DC24V 16 Output Points (5kpps pulse line output or 2.5kHz PWM x 4 points possible. *2)	○	○	○
Analog Input (12-bit resolution, no insulation between channels)	○ (2ch)	○ (2ch)	○ (2ch)
Analog Output (12-bit resolution, no insulation between channels)	○ (1ch)	○ (2ch)	○ (2ch)
Thermocouple Temperature Input (J/K) (no insulation between channels)	—	○ (3ch)	—
Pt100 Temperature Input (no insulation between channels)	—	—	○ (2ch)

\*1 Each point with matching hardware output is 10kpps single phase 4 ch or dual phase 1 ch + single phase 2 ch.  
\*2 Pulse line output is 4 points, with 4-point total 5kpps maximum, PWM 2.5kHz for each point, combined use of high-speed counter matching output. DC24V output capacity. (Output 0.5A x 8 points (1 common) / 0.2A x 8 points (1 common))

## Interfaces

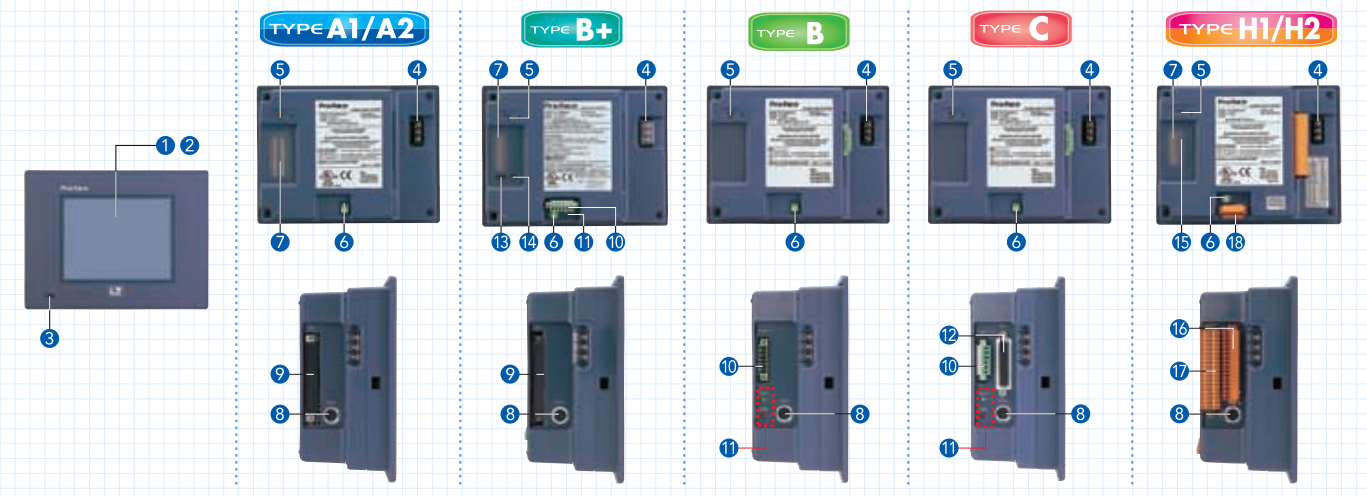

- Graphic Display Screen**  
Displays application screens and host data.
- Touch Panel**  
Switches screens, inputs values, provides switch and lamp functions, and writes data to host equipment.
- Status LED**  
Indicates the LT unit's operation status.
 

Controller mode <sup>1</sup>	LED	Operation mode <sup>2</sup>
RUN	Green - Lit	Offline
STOP	Green - Lit	Online
Backlight Malfunction Detected	Green - Blinking	Online
Major Error (STOP)	Green/Red - Lit	Online
	Red - Lit	Online
- Power Supply Terminal Block**  
Connects power and FG terminals.
- RUN/STOP Switch (LED is lit in RUN mode)**  
**RUN:** Executes logic program operation. In RUN mode, RUN/STOP of logic program can be controlled by Editor or Offline.  
**STOP:** Stops logic program operation. Stops the logic program regardless of the software setting.
- Alarm Output**  
Turns the contact OFF (open) when a major error or watchdog timer error is generated. See page 10, External Interfaces (Alarm Output).
- I/O LED (Type A1/A2/B+/H1/H2)**  
Indicates the input/output status of DIN/DOUT.
- Tool Connector**  
Connects to a data transfer cable.
- DIO Connector (Type A1/A2/B+)**  
Connects external input or output equipment.
 

<sup>1</sup> The Flex Network S-No. (node address) occupies one node in the Type B+DIO connector.
- Remote I/O (Flex Network) System Connector (Type B+/B/C)**  
Connects I/O units, analog units, or other Flex Network units via Flex Network communication cables.
- Flex Network Status LED (Type B+/B/C)**  
Indicates the status of Flex Network data communication.
 

Status LED	Description
RUN (Green)	Lit during normal operation.
ERR (Red)	Lit when communication with a connected unit is blocked.
- Serial I/F (Type C)**  
Connects a temperature controller, inverter or other external device, via an RS-232C or RS-422 cable.
- Dip Switches (Type B+)**  
These switches control the DIO connector's Output Hold. Also, they are used to set the S-No.'s left-most hex digit.
- Rotary Switch (Type B+)**  
Used to set the S-No.'s right-most hex digit.
- Ready LED (Type H1/2)**  
Indicates the LT unit's current status.
 

Status	LED
I/O board error	OFF
I/O board is normal	ON
- Analog Input/Output Connector (Type H1/2)**  
Connects control units such as sensors, using a screw-clamp type connector.
- DIO Input/Output Connector (Type H1/2)**  
Connects external Input/Output units, using a spring-clamp type connector.
- Temperature Input Interface (Type H1/2)**  
Connects Pt100 or thermocouple sensors using a screw-clamp type connector.  
<sup>1</sup> ADT/ADP Type only.

## Optional Items

	Product Name	Model	Description
Software	GP-PRO/PBIII C-Package 03	GPPRO-CNT01W-P03	LT Series development software
	Screen Protection Sheet (Hard Type)	GP37W2-DF00	Protects display surface and keeps unit clean (5 sheets/set)
Main Unit Options	DIO Connector & Cover (Soldered Type)	GLC100-DIOCN01	Type A1/A2/B+ DIO Connector (5 sets of connectors and covers)
	DIO Connector (Pressure Type)	GLC-DIOCN02	Type A1/A2/B+ DIO Connector (5 sets of connectors)
Maintenance Options	Installation Fasteners	GP070-AT01	For attaching LT Series unit to a solid panel. (set of 4)
	Installation Gasket	GP37W2-WP00-MS	For attaching LT Series unit to a solid panel.
	Flex Network I/F Connectors	FN-IFCN01	Type B+/B/C Flex Network Connectors (set of 5)
	DIO Connectors for LT Type H	GLC-DIOCN04	Attaches LT to DIO I/F (set of 2)
	Analog I/O Connectors for LT Type H	GLC-AIOCN01	Attaches LT to Analog I/F (set of 5)
Peripheral Unit Options	Temperature Input Connectors for LT Type H	GLC-TMCON01	Attaches LT to Temperature I/F (set of 5)
	RS-232C Cable	GP410-IS00-O	Interface cables for data transmission between host controllers and LT Series.
	RS-422 Cable	GP230-IS11-O	Interface cables for data transmission between host controllers and LT Series.
	Single-axis Teaching Loader	FN-PC10LD41	Program-input unit for the Flex Network Single-axis positioning unit. Used for parameter entry, as well as positioning check and movement. (Also includes one FN-LD10CBL.)
	Multi-Link Cable	GP230-IS12-O	RS-422 interface cable for multiple-type (n:1) data transmission between host controllers and LT Series units.
	RS-422 Connector Terminal Block Conversion Adapter	GP070-CN10-O	Converts SIO to RS-422 terminal block.
	Data Transfer Cable	GPW-CB02	Connect LT Series to a PC for downloading GP-PRO/PBIII C-Package data
	USB Data Transfer Cable	GPW-CB03	Connect LT Series to a PC for downloading GP-PRO/PBIII C-Package data
	DIO Cables	CGP070-ID11-M	Open-end Sink DIO cable, 3m (Type A1/A2/B+)
		GLC000-DIOCB11-MS	Open-end Sink/Source DIO cable, 3m (Type A1/A2/B+)
	I/O Connector Terminal Block for FN-XY32SKS41	GLC-DIOCN03	Flex Network 64-point DIO connector terminal blocks. Spring-clamp type (set of 2)
	Flex Network Communication Cables	(10m)	FN-CABLE 2010-31-MS
(50m)		FN-CABLE 2050-31-MS	
(200m)		FN-CABLE 2200-31-MS	
Single-axis Motor Driver Connection Cable (1m)	FN-PC10CB01	Connects the Flex Network Single-axis positioning unit and the servo and stepping drivers.	
Single-axis Teaching Loader Cable (5m)	FN-LD10CBL	Connects Single-axis Positioning unit to Single-axis Teaching Loader.	

\* Manual: Download the necessary PDF manuals from our web site (<http://www.pro-face.com>), or contact your local Pro-face distributor.

### I/O Interface Specifications

TYPE A1 TYPE A2 TYPE B+

#### Input

	Type A1/A2	Type B+
Rated Voltage	DC24V	
Max. Allowable Voltage	DC26.4V	
Input Type	Source/Sink input	
Rated Current	5mA (24V)	5.7mA (24V)
Input Resistance	4.7kΩ	4.2kΩ
Standard Operating Range	ON voltage: 21V or more., OFF voltage: 7V or less.	ON voltage: 15V or more., OFF voltage: 5V or less.
Input Delay	OFF → ON: 10ms or less., ON → OFF: 10ms or less.	OFF → ON: 1.5ms or less., ON → OFF: 1.5ms or less.
Common	1	
Common Structure	16 points / 1 common line	
External Connection	40-pin connector (also used for output)	
Input Points	16	
Input Signal Indication	LED lights for each point ON (logical side)	
Isolation Method	Photocoupler isolation	
External Power Supply	For Signal: DC24V	

#### Output

	Type A1/A2	Type B+
Rated Voltage	DC24V	
Rated Voltage Range	DC24V±10%	
Output Type	Type A1: Sink output Type A2: Source output	Sink output
Max. Load Current	0.2A/point, 1.6A/common	
Output Voltage Drop	2.5V or less	1.5V or less
Output Delay	OFF → ON: 2ms or less., ON → OFF: 2ms or less.	OFF → ON: 1ms or less., ON → OFF: 1ms or less.
Leakage Current when OFF	0.4mA or less 0.1mA or less	
Output Classification	Transistor output	
Common	1	
Common Structure	16 points / 1 common line	
External Connection	40-pin connector (also used for input)	
Output Protection Classification	No protection	
Internal Fuse	3.5A, 125V chip fuse (not replaceable)	
Surge Suppression Circuit	Diode	
Output Points	16	
Output Signal Indication	LED lights for each point ON (logical side)	
Isolation Method	Photocoupler isolation	
External Power Supply	DC24V	

### I/O Interface Connector Specifications, I/O Circuit Diagrams

TYPE A1 TYPE A2 TYPE B+

The sink/source type DIO integrates 16 input/output points into a compact unit. The Type A1/A2/B+ LT supports up to 16-point inputs and 16-point outputs, ideal for connecting peripheral I/O devices.

#### I/O Connectors (Type A1/B+: Sink Output)

Pin	Signal	Pin	Signal
A1	COM (0V:DOUT)	B1	COM (24V:DIN)
A2	COM (0V:DOUT)	B2	DC24V (DOUT)
A3	NC	B3	NC
A4	NC	B4	NC
A5	DOUT15	B5	DIN15
A6	DOUT14	B6	DIN14
A7	DOUT13	B7	DIN13
A8	DOUT12	B8	DIN12
A9	DOUT11	B9	DIN11
A10	DOUT10	B10	DIN10
A11	DOUT9	B11	DIN9
A12	DOUT8	B12	DIN8
A13	DOUT7	B13	DIN7
A14	DOUT6	B14	DIN6
A15	DOUT5	B15	DIN5
A16	DOUT4	B16	DIN4
A17	DOUT3	B17	DIN3
A18	DOUT2	B18	DIN2
A19	DOUT1	B19	DIN1
A20	DOUT0	B20	DIN0

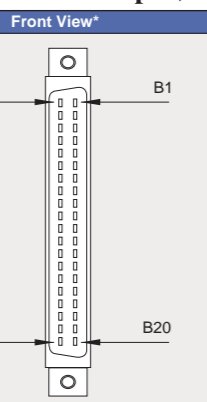

\* This front diagram shows the connector on the DIO unit side. When preparing the cable, note that the A and B characters indicate the number 1 pins.

#### I/O Connectors (Type A2: Source Output)

Pin	Signal	Pin	Signal
A1	COM (24V:DOUT)	B1	COM (0V:DIN)
A2	COM (24V:DOUT)	B2	0V (DOUT)
A3	NC	B3	NC
A4	NC	B4	NC
A5	DOUT15	B5	DIN15
A6	DOUT14	B6	DIN14
A7	DOUT13	B7	DIN13
A8	DOUT12	B8	DIN12
A9	DOUT11	B9	DIN11
A10	DOUT10	B10	DIN10
A11	DOUT9	B11	DIN9
A12	DOUT8	B12	DIN8
A13	DOUT7	B13	DIN7
A14	DOUT6	B14	DIN6
A15	DOUT5	B15	DIN5
A16	DOUT4	B16	DIN4
A17	DOUT3	B17	DIN3
A18	DOUT2	B18	DIN2
A19	DOUT1	B19	DIN1
A20	DOUT0	B20	DIN0

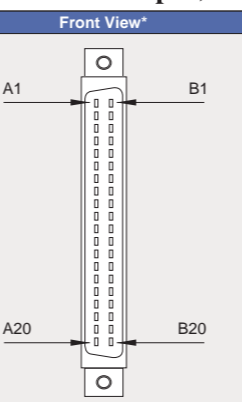

\* This front diagram shows the connector on the DIO unit side. When preparing the cable, note that the A and B characters indicate the number 1 pins.

#### I/O Circuit Connection

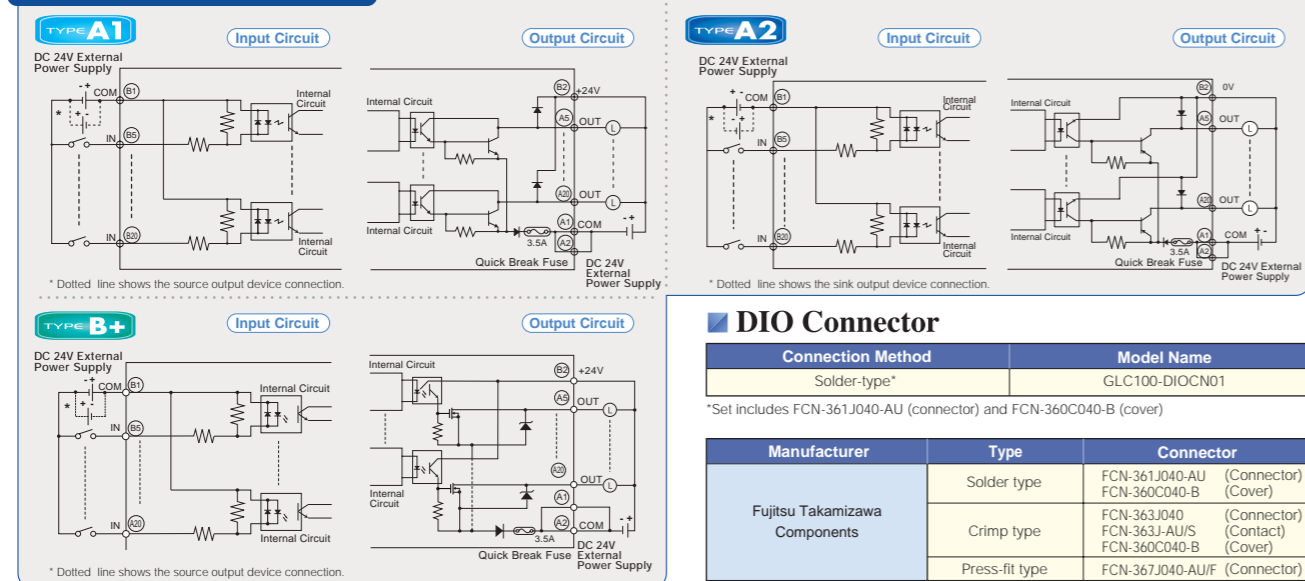

#### DIO Connector

Connection Method	Model Name
Solder-type*	GLC100-DIOCN01

\*Set includes FCN-361J040-AU (connector) and FCN-360C040-B (cover)

Manufacturer	Type	Connector
Fujitsu Takamizawa Components	Solder type	FCN-361J040-AU (Connector) FCN-360C040-B (Cover)
	Crimp type	FCN-363J040 (Connector) FCN-363J-AU/S (Contact) FCN-360C040-B (Cover)
	Press-fit type	FCN-367J040-AU/F (Connector)

### Remote I/O (Flex Network) Specifications

TYPE B+ TYPE B TYPE C

This I/F unit's high-speed remote I/O (6Mbps/12Mbps) is so fast, you won't think you are using a remote connection. Up to 1008 I/O points can be connected, with a communication delay of only 0.94ms (for 512 points at 12Mbps). The network can be extended up to 400 meters (2 channels at 6Mbps).

#### I/F Connector

Communication Configuration	1: N
Connection Method	Multi-Drop Connection
Max. Distance	200m/channel at 6Mbps, 100m/channel at 12Mbps
Communication Method	During cyclic period, distributed transmission. Half-duplex
Communication Speed	6Mbps/12Mbps (selectable)
Communication I/F	Differential Method, pulse transfer resistance
Error Check	Format, bit, or CRC-12 verification
Max. Number of Nodes	63 (max.), 1008 I/O points (depending on type of units used.)

Pin No.	Condition	Signal Name
6	Channel 2 shield line	SLD
5	Channel 2 communication data	TR-
4	Channel 2 communication data	TR+
3	Channel 1 shield line	SLD
2	Channel 1 communication data	TR-
1	Channel 1 communication data	TR+

### Serial I/F (SIO) Specifications

TYPE C

Serial I/F	Asynchronous; RS-232C/RS-422; data length: 7 or 8 bits; stop bit: 1 or 2 bits; parity: none, Transmission rate: 2400bps to 115.2Kbps
------------	---

**Recommended Connector:** Dsub 25-pin plug XM2A-2501 (Omron)  
**Recommended Cover:** Dsub 25-pin cover XM2S-2511 (Omron)  
Jack Screw XM2Z-0071 (Omron)  
\* Use M2.6 x 0.45 coarse thread screws to mount.  
**Recommended Cable:** CO-MA-VV-SB5P 28AWG (Hitachi Cable, Ltd)

Refer to the GP-PRO/PB-III External Device Connection Manual (included with the GP-PRO/PB-III C-Package) for external controller connection information, or visit our website.

#### I/O Connector Specifications

Pin	Code	Signal Name	Front View
1	FG	Frame Ground	
2	SD	Send Data (RS-232C)	
3	RD	Receive Data (RS-232C)	
4	RS	Request Send (RS-232C)	
5	CS	Clear Send (RS-232C)	
6	NC	No Connection	
7	SG	Signal Ground	
8	CD	Carrier Detect (RS-232C)	
9	TRMX	Termination (RS-422)	
10	RDA	Receive Data A (RS-422)	
11	SDA	Send Data A (RS-422)	
12*	RESERVE	Reserved	
13*	RESERVE	Reserved	
14	VCC	5V ±5% Output 0.25A	
15	SDB	Send Data B (RS-422)	
16	RDB	Receive Data B (RS-422)	
17	NC	No Connection	
18	CSB	Clear Send B (RS-422)	
19	ERB	Enable Receive B (RS-422)	
20	ER	Enable Receive (RS-232C)	
21	CSA	Clear Send A (RS-422)	
22	ERA	Enable Receive A (RS-422)	
23	NC	No Connection	
24	NC	No Connection	
25	NC	No Connection	

\*Pins 12 and 13 are reserved and are not available for connection.

### Common I/F Specifications

TYPE A1 TYPE A2 TYPE B+ TYPE B TYPE C TYPE HI TYPE H2

#### Alarm Output

Contact Rating	AC125V at 0.15A (resistive load), DC24V at 0.6A (resistive load)
Set Time (at 20°C)	4ms or less
Reset Time (at 20°C)	4ms or less
Min. Switching Load	1mA/DC5V
Initial Contact Resistance	100mΩ or less

When the LT unit's power is turned ON, the Alarm Output is turned OFF for approximately 1 second. Be sure to design your circuits to disregard a 1 second Alarm Output stop after the LT unit's power is turned ON.

Note: This relay switch is OFF from the time the power is turned on until the LT Series system is booted. The external monitoring circuit must be started after the LT Series system is booted.

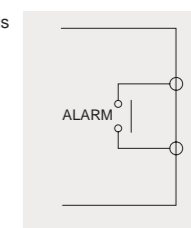

#### Tool Connector

Tool Connector	Asynchronous; TTL level non-procedural command I/O <b>During Screen File Development</b> : Connect data transfer cable for transferring data from GP-PRO/PB-III C-Package. <b>During Operation</b> : Connect a variety of devices including a bar-code reader.
----------------	--

## I/O Interface Specifications



### Input

Item	Specification
Rated Voltage	DC 24V
Max. Allowable Voltage	DC 28.8V
Input Method	Source/Sink input
Rated Current	9 mA (DC24V) (IN0, IN2, IN4, IN6) 5 mA (DC24V) (Other input)
Input Impedance	Approx. 2.7kΩ (IN0, IN2, IN4, IN6) Approx. 4.7kΩ (Other input)
Input Derating	*1
Operation Range	ON Voltage: DC19V or more OFF Voltage: DC5V or less
Input Delay Time	OFF to ON: 0.5 to 20ms or less*2 ON to OFF: 0.5 to 20ms or less*2
Common Lines	2
Common Line Allocation	8 points/1 common line
Input Points	16
Input Signal Display	LED lights when each point turns ON (logical side)
Isolation Method	Photocoupler Isolation
Polarity	None
External Power Supply	For signal: DC 24V

\*1 Exceeding the LT unit's input rated voltage may affect the input ON voltage, input points, or ambient operating temperature; the unit's input terminals may be damaged due to excessive heat. Use Input Derating within the range shown in the chart below, to prevent unit malfunction.

\*2 Digital filter can be set at intervals of 0.5ms.

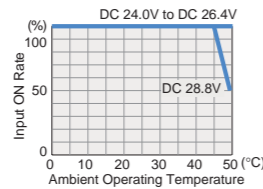

### DIO Connector

Pin No.	Signal Name	Pin No.	Signal Name	Pin Assignments
A1	OUT15	B1	IN15	
A2	OUT14	B2	IN14	
A3	OUT13	B3	IN13	
A4	OUT12	B4	IN12	
A5	OUT11	B5	IN11	
A6	OUT10	B6	IN10	
A7	OUT9	B7	IN9	
A8	OUT8	B8	IN8	
A9	COM3	B9	COM1	
A10	OUT7	B10	IN7	
A11	OUT6	B11	IN6 (CT3)	
A12	OUT5	B12	IN5	
A13	OUT4	B13	IN4 (CT2)	
A14	OUT3 (PLS3, PWM3)	B14	IN3	
A15	OUT2 (PLS2, PWM2)	B15	IN2 (CT1)	
A16	OUT1 (PLS1, PWM1)	B16	IN1	
A17	OUT0 (PLS0, PWM0)	B17	IN0 (CT0)	
A18	COM2	B18	COM0	

Using GP-PRO/PBIII C-Package 03, you can set the standard DIO for use as high-speed counter input. Refer to the Manual.  
 • Parenthesized signal names ( ) indicate when Pulse output (PLS), PWM output (PWM), or Counter Input (CT) are used.  
 • B2L3.5/36LH 36 pole spring-clamp connector (Weidmuller) Wire size: 0.3mm to 1.0mm (AWG#18 to AWG#22)  
 • The terminals for DIO power supply are located on the analog input/output connector.

### About COM

Pin No.	Signal Name	Function
B18	COM0	Input Common (For IN0 to IN7) (For CT0 to CT3)
B9	COM1	Input Common (For IN8 to IN15)
A18	COM2	Output Common (For OUT0 to OUT7) (For PLS0 to PLS3, PWM0 to PWM3)
A9	COM3	Output Common (For OUT8 to OUT15)

### High-speed Counter Input

Item	Specifications
Counter Input*	DC 24V (Open Collector) Single Phase (4 points) 2-Phase (One point)
Counter Input Points	CT0(IN0), CT1(IN2), CT2(IN4), CT3(IN6) CT0(IN0), CT1(IN2) are used as a pair CT0: A Phase, CT1: B Phase
Input Voltage	ON Voltage: DC19V or more / OFF Voltage: DC5V or less.
Input Impedance	2.7 kΩ
Minimum Pulse Width (Pulse Input)	
Calculated Speed (Rise and Fall time)	
Phase	1 phase 90 degree phase differential-2 phase signal, 1 phase +directional signal
Max. Count Frequency	10kpps
Count Edge Assignment	Available Not Available
Count Register	16 bit Up/Down counter
Counter Mode Switch	Depending on software settings
Upper/Lower Limit Setting	Not available
Preload/Prestrobe	Available
Marker Input (Counter Value Clear)	None IN3

\* Select one from the types listed.

### Output

Item	LC (Low Current) OUT0 to OUT7	HC (High Current) OUT8 to OUT15
Rated Voltage	DC 24V	
Rated Voltage Range	DC 20.4V to DC 28.8V	
Output Method	Type H1 Sink Output	Type H2 Source Output
Maximum Load Current	0.2 A/point 0.8 A/common	0.5 A/point 2 A/common
Output Voltage Drop	0.5V or less	
Output Delay Time	OFF to ON: 0.5 ms or less, ON to OFF: 0.5 ms or less	
Current Leakage (when OFF)	0.1 mA or less	
Type of Output	Transistor Output	
Common Lines	1 each	
Common Design	8 points/1 common line	
Output Points	16 (8 points/1 common line)	
Output Protection Type	Output is unprotected	
Internal Fuse	2A Chip Fuse (non-replaceable)	5A Chip Fuse (non-replaceable)
Surge Control Circuit	Zener Diode (DC39V±1V)	
Output Signal Display	LED lights when each point turns ON (logical side)	
Isolation Method	Photocoupler Isolation	
External Power Supply	For signal: DC 24V	

### I/O Circuit Connection

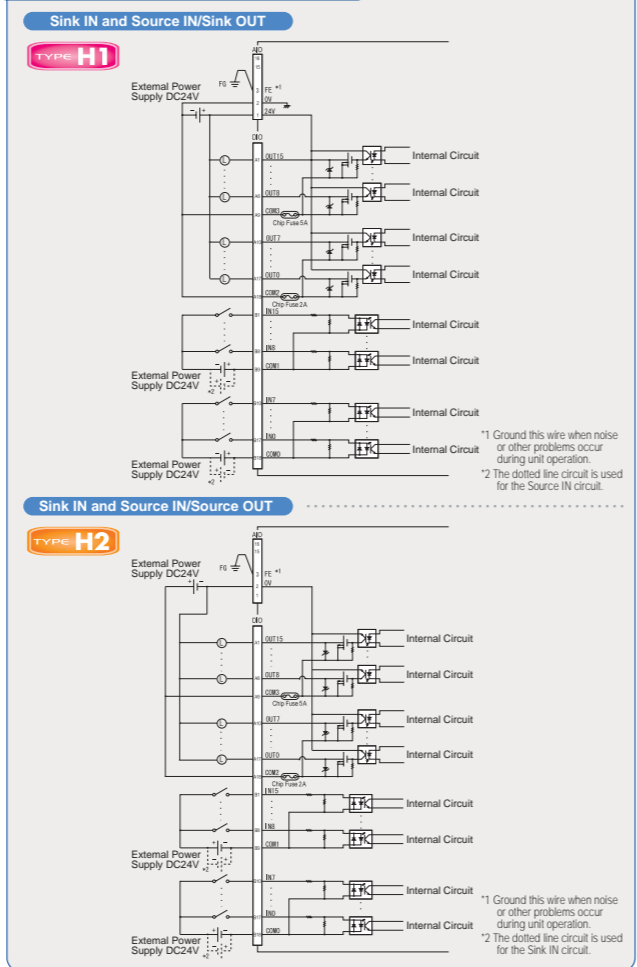

### Pulse/PWM Output

Item	Specification	
	Pulse Output	PWM Output
Output Points	4 Points	
Output Method	PLS0 to PLS3 (OUT0 to OUT3) defined by user	PWM0 to PWM3 (OUT0 to OUT3) defined by user
Load Voltage	DC24V	
Min. Load Current	1mA	
Max. Output Frequency	—	2.5kHz
Pulse Array Maximum Output Frequency	5kHz	—
(Total number of used channels)	—	—
Pulse Acceleration/Deceleration Speed	Available	
ON Duty	50% +/-20% (at 5kHz) *1	10% to -90% (at 2.5kHz) *2

\*1 The ON Duty error (20%) will be reduced if the Output frequency is low.  
 \*2 The ON Duty (effective range) will be widened if the Output frequency is low.

## Analog Input/Output



### Input

Item	Specifications
No. of Input Channels	2 Channels
Input Range	At Voltage Setup: 0V to 10V (10.2375V max.) *1 At Current Setup: 0mA to 20mA (20.475mA max.) *1
Resolution	At Voltage Setup: 12 Bit (0-4000 (0V to 10V), 4095 max. (at 10.2375V)) At Current Setup: 12 Bit (0-4000 (0mA to 20mA), 4095 max. (at 20.475mA))
Brightness	±1.0% of full scale (0°C to 50°C)
Linearity	±3 LSB max.
Input Impedance	At Voltage Setup: 100kΩ At Current Setup: 250Ω
Input Delay Time	Scan time + (2ms x Input Channels)
Absolute Max. Input Voltage	DC15V (Voltage)/ 60mA (Current)
Input Filter	Move average sampling time 2ms
Power Supply	DC24V External Power Supply
Insulation	Each channel - Internal: Insulated Between each channel: No Insulated Each channel - Analog Power: Insulated
Input Characteristics	Input Voltage
	Input Current

\*1 Switching the Voltage Input or Current Input can be set separately, in each channel.

### Output

Item	Specifications
No. of Output Channels	AD: 1 Channel ADP: 2 Channels ADT: 2 Channels
Output Range	At Voltage Setup: 0V to 10V (10.2375V max.) *1 At Current Setup: 0mA to 20mA (20.475mA max.) *1
Resolution	At Voltage Setup: 12 Bit (0 to 4000 (0V to 10V), 4095 max. (at 10.2375V)) At Current Setup: 12 Bit (0 to 4000 (0mA to 20mA), 4095 max. (at 20.475mA))
Brightness	±1.0% of full scale (0°C to 50°C)
External Allowable Load	At Voltage Setup: 10kΩ or more At Current Setup: 500Ω or less
Power Supply	DC24V External Power Supply
Insulation	Each channel - Internal: Insulated Between each channel: Non-Insulated Each Analog Power channel: Insulated
Output Characteristics	Output Voltage
	Output Current

\*1 Switching the Voltage Input or Current Input can be set separately, in each channel.

**Important:**  
 • Use twisted-pair, shielded coaxial cable for analog input line(s) and be sure these lines are placed in a separate duct from high-frequency, live lines such as high-voltage, high-power lines, inverters, etc.

### Analog I/O Circuit Connection

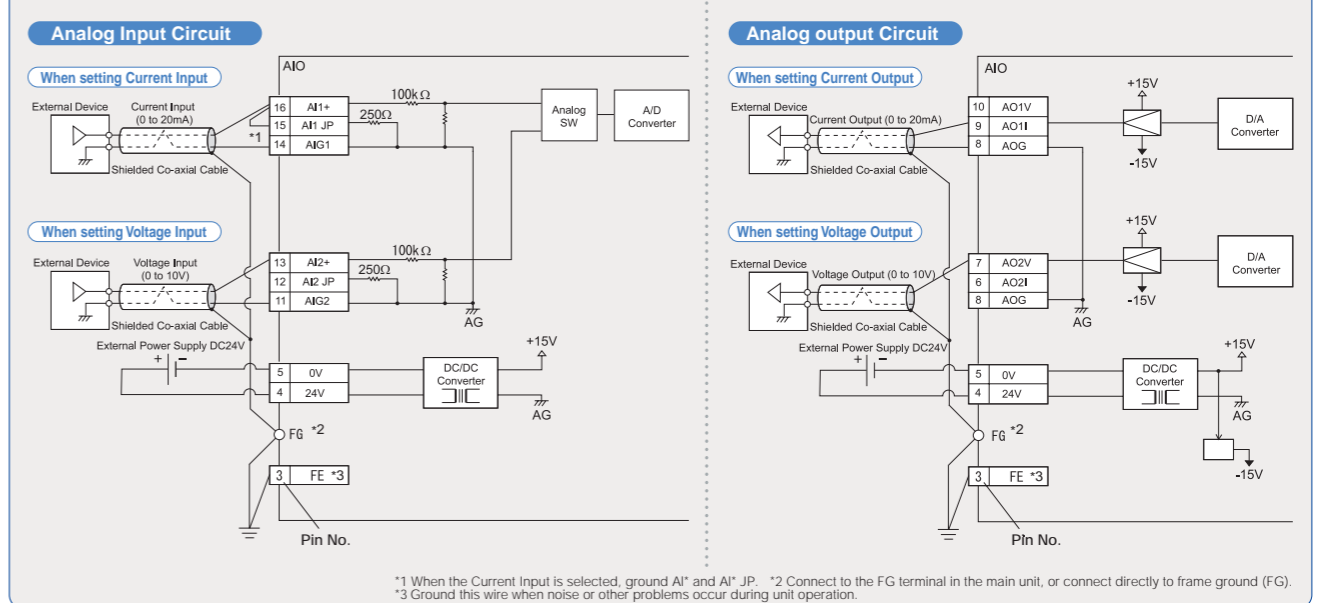

### Input/Output Connector\*1

Pin No.	Signal Name	Condition	Pin Assignments*2
1	24V	DIO Power 24V	
2	0V	DIO Power 0V	
3	FE	Terminal for Function Ground *3	
4	24V	Analog Power 24V	
5	0V	Analog Power 0V	
6	AO2I	Ch2 Analog Output (Current)	
7	AO2V	Ch2 Analog Output (Voltage)	
8	AOG	Analog Output Ground	
9	AO1I	Ch1 Analog Output (Current)	
10	AO1V	Ch1 Analog Output (Voltage)	
11	AI2G	Analog Input Ground	
12	AI2 JP	Ch2 Analog Input	
13	AI2 +	Ch2 Analog Input	
14	AI1G	Analog Input Ground	
15	AI1 JP	Ch1 Analog Input	
16	AI1 +	Ch1 Analog Input	

\*1 A connector terminal block is included with the unit, and is also available separately as a maintenance option.  
 \*2 Recommended Connector and Wire.  
 BL3.5/16LH 16 pole screw-clamp type connector (Weidmuller).  
 Terminal block screw fastening torque: 0.2 to 0.4N·m.  
 Maximum wire size: 1.6mm (AWG#14), Applicable to UL1015 or UL1007  
 Wire strip length: 4.5 to 6.0 mm [0.18 in. to 0.24 in.]  
 \*3 Ground this wire when noise or other problems occur during unit operation.

Temperature Input



Pt100 Input

Specifications table for Pt100 input including Subjected Resistance, Measurable Temperature Range, Accuracy, and Input Characteristics graphs.

\*1 Temperature conversion data is indicated as the measured value x10. \*2 Except for delay time, depending of the LT unit's scan time.

Thermocouple Input

Specifications table for Thermocouple input including Subjected Resistance, Measurable Temperature Range, Accuracy, and Input Characteristics graphs.

\*1 Temperature conversion data is indicated as the measured value x10. \*2 Except for delay time, depending of the LT unit's scan time.

Temperature Input Connector\*1 (TypeH\*-ADP)

Table for Temperature Input Connector (TypeH\*-ADP) showing Pin No., Terminal Name, Condition, and Pin Assignments.

\*1 A connector terminal block is included with the unit, and is also available separately as a maintenance option. \*2 Applicable connector: Weidmuller BL3.5/6LH 6-terminal screw clamp. Max. connectable wire size: 1.6 mm (AWG#14)

Thermocouple Input Connector\*1 (TypeH\*-ADT)

Table for Thermocouple Input Connector (TypeH\*-ADT) showing Pin No., Terminal Name, Condition, and Pin Assignments.

\*1 A connector terminal block is included with the unit, and is also available separately as a maintenance option. \*2 Applicable connector: Weidmuller BL3.5/6LH 6-terminal screw clamp. Max. connectable wire size: 1.6 mm (AWG#14)

Pt100 Input Circuit Connection

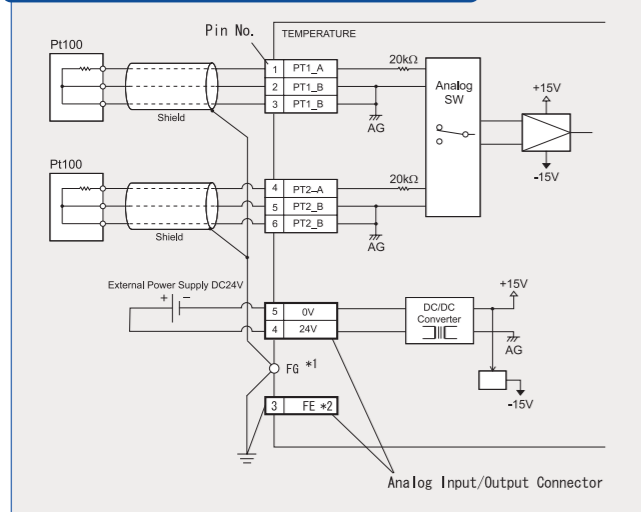

\*1 Connect to the FG terminal in the main unit, or connect directly to frame ground (FG). \*2 Ground this wire when noise or other problems occur during unit operation.

Important: When extending the Pt100 input wire, make sure that the three conductors have exactly the same resistance and length. Do not route this wire near high-voltage, high-current, high-frequency cables...

Thermocouple Input Circuit Connection

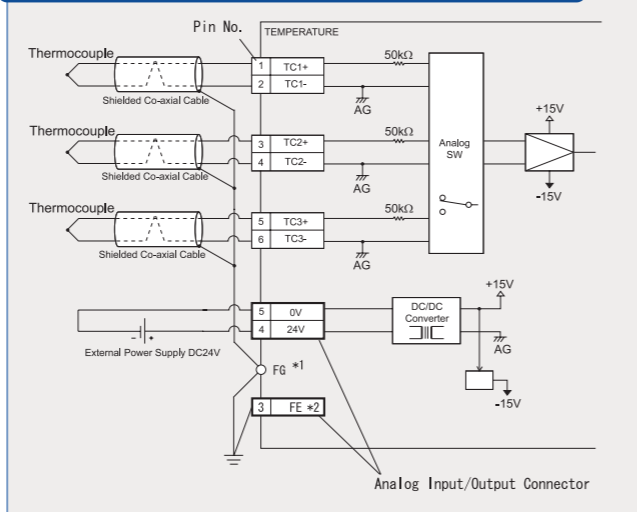

\*1 Connect to the FG terminal in the main unit, or connect directly to frame ground (FG). \*2 Ground this wire when noise or other problems occur during unit operation.

Important: Do not route thermocouple input wiring near high-voltage, high-current, high-frequency cables (such as those for inverters) or power cables. Also, do not bundle it with any of these cables...

Connectable Controllers



All equipment in these lists has been tested with GP-PRO/PBIII C-Package03 software. (as of February 2004)

Temperature Controllers\*1

Large table listing various temperature controllers from manufacturers like Yokogawa M&C, Yamatake, OMRON, Shinko Technos, Fuji Electric, RKC Instrument, Toho Denshi, and Shimaden, including Series Name, Model, and specifications.

\*1 The □ indication varies depending on the temperature controller functions. \*2 The □ value varies depending on the functional specification. Depending on the functional specification, the ■ is omitted. \*3 Communication is possible via the LT Series internal memory regardless of the external controller (PC, Single-board controller, etc.).

Inverters\*2

Table listing inverters from manufacturers like Mitsubishi Electric, Yasukawa Electric, and Fuji Electric, including Series Name and Model.

Servos

Table listing servos from manufacturers like Matsushita Electric, including Series Name and Model.

Analyzer

Table listing analyzers from manufacturer JT Engineering, including Series Name and Model.

Memory Link (General-Purpose Protocol)\*3



# GP-PRO/PBIII C-Package03

Screen Editor and Logic Program Development Software

Software that integrates screen creation and logic programming in a single, easy-to-use package. Creates effective GUI screens with easy steps and even provides new users reliable basic programming.



## Conforms to IEC61131-3 International Standard

The GP-PRO/PBIII C-Package03 logic program conforms to IEC61131-3, the de facto international standard for controller programming languages. As open architecture systems grow in popularity, there is now a strong need to standardize control program development languages.

Tomorrow's Industry Standard

### STEP 1 Set up your logic program

**Programming that is as easy as drag & drop!**

Form ladder circuits by combining ladder commands from 71 categories. Allows the user to program by simply dragging and dropping.

\* Also allows importing of circuits from other files.

**Easy for beginning programmers. I/O setting by simple operations.**

Just drag & drop the combined variable name to the desired I/O terminal diagram. Even beginning programmers can create structures, easily and with confidence.

### STEP 2 Set the logic program and screen

**Drag & drop ladder commands onto the screen.**

Create a screen with push buttons and meters just by using the mouse to drag & drop logic program ladder commands onto the screen being developed.

### STEP 3 Create your screens

**Choose from a total of 1,840 pre-made parts.**

Simply select the switches, lamps, meters, and other parts you want, and place them as desired on the screen. These full-featured, easy-to-read parts make it easy to create the screens you want.

**Add original graphics and text.**

Use drawing tools to create shapes and lines, and add text with the same ease as a word processor.

\* Also allows importing screen content from other files.

### STEP 4 Check operations

**Easy maintenance, too!**

Quickly give on-site support! Boost performance!

Before connecting to line equipment, check operations by connecting LT to a personal computer.

Software upgrades are easy. Simply connect a cable between LT and the equipment.

### STEP 5 Operation

Simply connect to the equipment. You will be able to control the equipment using touch screen operations on LT.

### GP-PRO/PBIII C-Package03 Software Environment Specifications

Product No.	P C	Screen Resolution	Hard Disc Space	Memory	Drive Type	O S
GP-PRO-CNT01W-P03	Windows® compatible PC with Intel Pentium II 266MHz or Faster.	SVGA (800×600pixels) or higher	Maximum:210MB * Project file size after installation will require at minimum three times more space.	Minimum:32MB Recommended:64MB or more	CD-ROM Drive	Windows® 95/98/2000/Me/XP Windows NT® (4.0 or later) (Windows NT® 4.0 Service pack 3 or later)

\* Requires a COM port or USB port Ethernet port on the PC for transferring screen data.

## New Easy-to-use Features

### Supports Ladder Monitor

Provides control in emergency situations, when you want to see equipment programs on location. Allows LT ladder monitoring on the touch panel without disrupting control or PLC communication and scrolls easily through monitor screens. Variable monitoring (device) and decimal or hexadecimal display are also possible.

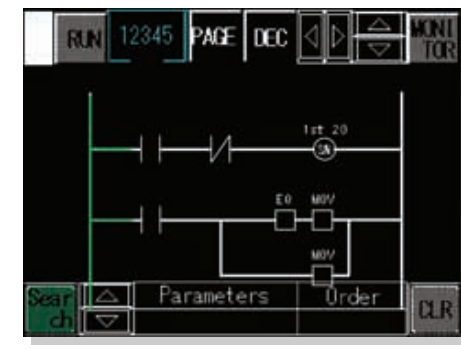

### Wide Range of Ladder Commands

Altogether, 71 different ladder commands are available. Easy programming makes GP-PRO/PBIII C-Package03 ideal for a small PLC.

Command extensions	Type
SUM	Sum (Returns total value of input array)
AVE	Average (Returns average value of input array)
RCL	Left Rotation with Carry
RCR	Right Rotation with Carry
SAL	Arithmetic Shift Left
SAR	Arithmetic Shift Right
BCNT	Bit Count
ASIN	Arc sine
ACOS	Arc cosine
ATAN	Arc tangent
COT	Cotangent
EXP	Exponent e(x)->y
LN	Natural logarithm loge(x)->y
DEG	Degree Conversion (Radians->Degrees)
SQRT	Square Root
RAD	Radian Conversion (Degrees->Radians)

### Better Input Functionality with Pop-up Keyboards

When using the touch panel to enter values in a settings display, the pop-up keyboard is launched by simply touching the settings display.

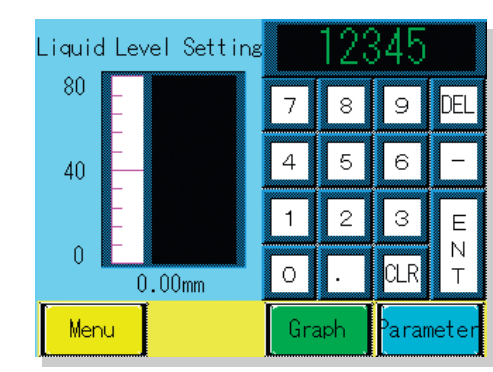

### Supports Many Kinds of Graphs

Freely choose among line graphs, pie charts, and other kinds of graphs by simply dragging and dropping from the library. Also supports selection of graph background color, making graphs easier to see and use. In addition, the background color for each part can be adjusted to provide easily recognizable screens.

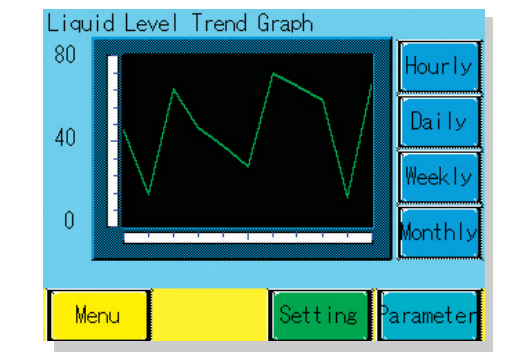

### Improved Alarm History Functions

An "Alarm Acknowledge Time/Recovery Time" display has been added to the information presented during an emergency. History function improvements result in better support during emergencies.

Date	Occur	Alarm Message	Check	Recover
04/04/04	10:00:25	Tank5: Low Level	11:05:46	15:03:02
04/04/04	11:20:30	Bulb4: Closed	12:40:22	16:42:37
04/05/04	12:45:30	Tank4: Low Pressure	14:51:32	16:13:41
04/05/04	15:25:34	Mixer4: Stopped	15:40:21	17:23:04

## Ladder Logic Instruction List

Class	Type	Inst.	Symbol	Class	Type	Inst.	Symbol	Class	Type	Inst.	Symbol	Class	Type	Inst.	Symbol
Discrete Instructions	Normally Open	NO		Shift Instructions	Rotate Right	ROR		Comparison Instructions	Greater Than (>)	GT		Convert Instructions	Degree Conversion (Radians→Degrees)	DEG	
	Normally Closed	NC			Shift Left	SHL			Greater Than or Equal To (>=)	GE			Radian Conversion (Degrees→Radians)	RAD	
	Positive Transition	PT			Shift Right	SHR			Less Than (<)	LT			sine function	SIN	
	Negative Transition	NT			Left Rotation with Carry	RCL			Less Than or Equal To (<=)	LE			cosine function	COS	
	Output Coil	OUT			Right Rotation with Carry	RCR			Not Equal (<=)	NE			tangent function	TAN	
	Retention Coil	M			Arithmetic Shift Left	SAL			PID Calculation	PID			Arc sine	ASIN	
	Negated Coil	NEG			Arithmetic Shift Right	SAR			On Delay Timer	TON			Arc cosine	ACOS	
	Negated Retention Coil	NM			Add	ADD			Off Delay Timer	TOF			Arc tangent	ATAN	
	Unlatch Coil	RST			Subtract	SUB			Timer Pulse	TP			Cotangent	COT	
	Unlatch Retention Coil	RM			Multiply	MUL			Up Counter	CTU			Exponent	EXP	
Latch Coil	SET		Divide	DIV		Down Counter	CTD		Natural logarithm	LN					
Latch Retention Coil	SM		Residual Processing	MOD		Up/Down Counter	CTUD		Jump	JMP	→LabelName				
Arithmetic Operation Instructions	Logical Multiply	AND		Decrement	DEC		BCD Conversion	BCD		Jump to Subroutine	JSR	→SubroutineName←			
	Bit Negation	NOT		Increment	INC		Encode	ENCO		Return from Subroutine	RET	←RETURN←			
	Logical Add	OR		Square Root	SQRT		Decode	DECO		Repeat	FOR				
	Exclusive Logical Add	XOR		Equal To (=)	EQ		Binary Conversion	BIN			NEXT				
	Block Transfer	BMOV		Mathematical Instructions	Special Instructions	Timer and Counter Instructions	Convert Instructions	Function Control Instructions	Program Control Instructions						
Fill Transfer	FMOV														
Transfer	MOV														
Sum	SUM														
Average	AVE														
Bit Count	BCNT														
Rotate Left	ROL														

## Remote I/O (Flex Network) Specifications



### DIO Terminals

Model	FN-X16TS41	FN-XY08TS41	FN-Y08RL41	FN-Y16SK41	FN-Y16SC41	
Unit Rated Voltage	DC24V					
Allowable Voltage Range	DC20.4V to DC28.8V					
Allowable Voltage Drop	10ms or less (for DC24V power supply)					
Internal Power Consumption	1.5W or less		1.0W or less		1.5W or less	
Voltage Endurance	AC1500V at 10mA for 1 minute (between power/Input and Output, and FG terminals)					
Insulation Resistance	Above 10MΩ at DC500V (between power/Input and Output, and FG terminals)					
Operating Temperature	0°C to 55°C					
Storage Temperature	-25°C to +70°C					
Operating Humidity	5% RH to 95% RH (non-condensing) wet bulb temperature: less than 39°C					
Storage Humidity	5% RH to 95% RH (non-condensing) wet bulb temperature: less than 39°C					
Air Purity	0.1mg/m <sup>3</sup> or less (non-conductive levels)					
Pollution Degree	Pollution degree 2					
Corrosive Gases	Free of corrosive gases					
Vibration Resistance	5Hz to 55Hz, 60m/s <sup>2</sup> in X, Y, Z directions for 2 hours each					
Noise Immunity (via noise simulator)	Noise voltage: 1000Vp-p, Pulse Duration: 1μs, Arise time: 1ns					
Electrostatic Discharge Immunity	Contact discharge of 6kV (IEC 61000-4-2 Level 3)					
Installation Method	Using 35mm DIN rail or screws					
Cooling Method	Natural air circulation					
Weight	0.15kg [0.33lb] or less					
External Dimensions	W108mm [4.25in] x H45mm [1.77in] x D49mm [1.92in]					
Rating	IP20 *1					
Input	Rated Input Voltage	DC24V		---		
	Max. Input Voltage	DC28.8V		---		
	Input Points	16 points (common for sink/source types)	8 points (common for sink/source types)	---		
	Input Type	Type 1 *2				
	Input ON Voltage	DC15V or more				
	Input OFF Voltage	DC5V or less				
	Input Impedance	4.1kΩ				
	Input Delay	OFF - ON	1.5ms or less		---	
		ON - OFF	1.5ms or less		---	
	Output	Rated Output Voltage (from V+ to V-)	---			
Voltage Range (from V+ to V-)		---				DC20.4V to DC28.8V
No. of Output Points		---	8 points (open drain sink output)	8 points	16 points (open drain sink output)	16 points (open drain source output)
Max. Load Voltage		---	0.2A/point (8 points/1 common, max. common current 1.6A)	1.0A/point (8 points/1 common, max. common current 4.0A)	0.2A/point (16 points/1 common, max. common current 2.0A)	
Short-circuit Protection		---	None	---	None	
Voltage Drop (ON Voltage)		---	DC1.5V or less	---	DC1.5V or less	
Clamp Voltage		---	DC39V±1V	---	DC39V±1V	
Leakage Current		---	0.1mA or less	---	0.1mA	
Output Delay		OFF - ON	1ms or less		10ms or less	1ms or less
		ON - OFF	1ms or less		5ms or less	1ms or less
Contact Rating	---	---	1A at AC240V (resistive load, dielectric load) 1A at DC24V (resistive load, dielectric load)	---		
Min. Closing Load	---	---	1mA/DC5V	---		
Initial Contact Resistance	---	---	50mΩ or less	---		
Electrical Lifetime	---	---	100,000 operations or more	---		
Mechanical Lifetime	---	---	20,000,000 operations or more	---		
Number of Occupied Nodes	1					

\*1 When terminal is tightened.  
\*2 Digital input for detecting signal from relay contact points, push buttons, switches or other mechanical contact point devices.

# Remote I/O (Flex Network) Specifications



## DIO Terminals

	FN-X32TS41	FN-XY16SK41	FN-XY16SC41	FN-XY32SKS41	
Electrical	Unit Rated Voltage	DC24V			
	Allowable Voltage Range	DC20.4V to DC28.8V			
	Allowable Voltage Drop	10ms or less (for DC24V power supply)			
	Internal Power Consumption	2.5W or less	3.5W or less		
Environmental	Voltage Endurance	AC500V at 10mA for 1 minute (between power/Input and Output, and FG terminals)			
	Insulation Resistance	Above 10MΩ at DC500V (between power/Input and Output, and FG terminals)			
	Operating Temperature	0°C to 55°C			
	Storage Temperature	-25°C to +70°C			
	Operating Humidity	5% RH to 95% RH (non-condensing) wet bulb temperature: less than 39°C			
	Storage Humidity	5% RH to 95% RH (non-condensing) wet bulb temperature: less than 39°C			
	Air Purity (Dust)	0.1mg/m <sup>3</sup> or less (non-conductive levels)			
	Pollution Degree	Pollution Degree 2			
	Corrosive Gases	Free of corrosive gases			
	Vibration Resistance	*1			
Structural	Installation Method	Using 35mm DIN rail or screws			
	Cooling Method	Natural air circulation			
	Weight	350g or less			
Input/Output	External Dimensions (W) x (H) x (D)	110mm (4.33in) x 95mm (3.74in) x 57mm (2.24in)		135mm (5.31in) x 95mm (3.74in) x 46mm (1.81in)	
	Rating	IP20 *2		IP20 (Without terminal block)	
	Rated Input Voltage	DC24V			
	Max. Input Voltage	DC28.8V			
	No. of Input Points	32 points (common for sink/source types-dual use)	16 points (common for sink/source types-dual use)	32 points (common for sink/source types-dual use)	
	Input Type	Type 1 *3			
	Input ON Voltage	DC15V or more			
	Input OFF Voltage	DC5V or less			
	Input Impedance	4.2kΩ			
	Input Delay	OFF - ON	1.5ms or less		
		ON - OFF	1.5ms or less		
	Rated Output Voltage (from V+ to V-)	DC24V			
	Rated Output Voltage Range (from V+ to V-)	DC20.4V to DC28.8V			
Output Points	—	16 points (open drain sink output)	32 points (open drain sink output)		
Max. Load Voltage	—	0.2A/point (16 points/1 common, max. common current 1.6A)			
Short-circuit Protection	—	none			
Voltage Drop (ON Voltage)	—	DC1.5V or less			
Clamp Voltage	—	DC39V±1V			
Current Leakage	—	0.1mA or less			
Output Delay time	OFF - ON	1ms or less			
	ON - OFF	1ms or less			
Number of Occupied Nodes	2	1	4		

\*1 JIS B 3502, IEC61131-2 compliant Intermittent vibration: 10 to 57Hz, 0.075mm/s<sup>2</sup>; 57 to 150Hz, 9.8m/s<sup>2</sup>; Continuous vibration: 10 to 57Hz, 0.035mm/s<sup>2</sup>; 57 to 150Hz, 4.9m/s<sup>2</sup>; Ten times (for 80 minutes each) in X, Y, and Z directions.  
 \*2 With terminal block attached.  
 \*3 Digital input is for detecting signals from mechanical switching devices such as relay contacts, push buttons, switches, etc.

### Input derating for the FN-XY32SKS41

If this unit is used at a voltage that exceeds the rated input voltage, a combination of factors, including the input ON voltage, the number of input points, and the ambient temperature may lead to malfunction due to excessive heat in the input section. To prevent this kind of malfunction, use the table at the right to ensure that the input derating is within the range shown.

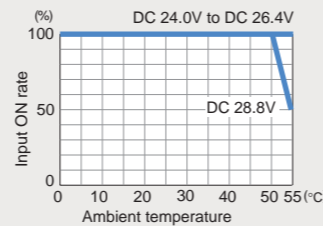

\*The FN-XY32SKS41 uses a spring-clamp type terminal block.

## Analog Units



	FN-AD04AH11	FN-DA04AH11		
Electrical	Unit Rated Voltage	DC24V		
	Allowable Voltage Range	DC20.4V to DC28.8V		
	Allowable Voltage Drop	10ms or less (for DC24V power supply)		
	Internal Power Consumption	4.8W or less	7.2W or less	
Environmental	Voltage Endurance	AC1500V 10mA 1 min. (between input/output and FG terminals) AC500V 1 min. (between power supply 1st Level and 2nd Level)		
	Insulation Resistance	DC500V at 10MΩ or higher (between charging and FG terminals)		
	Ambient Operating Temperature	0°C to 55°C		
	Storage Temperature	-25°C to +70°C		
	Ambient Humidity	30% RH to 95% RH (non-condensing) Level RH-1		
	Storage Humidity	30% RH to 95% RH (non-condensing) Level RH-1		
	Dust	0.1mg/m <sup>3</sup> or less (non-conductive levels)		
	Atmosphere	Free of corrosive gases		
	Vibration Resistance	*1		
	Noise Immunity (via noise simulator)	Noise voltage: 1000Vp-p, Pulse Duration: 1μs, Arise time: 1ns		
Structural	Electrostatic Discharge Immunity	Contact discharge of 6kV (IEC 61000-4-2 Level 3)		
	Installation Method	Using 35mm DIN rail or screws		
	Cooling Method	Natural air circulation		
Input/Output	Weight	0.35kg [0.77lb] or less		
	External Dimensions	W168mm [6.61in] x H50mm [1.96in] x D50mm [1.96in]		
	Rating	IP30		
	Resolution	12bit		
	Output/Input Channels	4 (fixed)		
	Conversion Time	2ms or less		
	Input/Output Range	0 to 5V (impedance 1MΩ)	0 to 5V (impedance 1kΩ)	
		1 to 5V (impedance 1MΩ)	1 to 5V (impedance 1kΩ)	
		0 to 10V (impedance 1MΩ)	0 to 10V (impedance 1kΩ)	
		-5 to 5V (impedance 1MΩ)	-5 to 5V (impedance 1kΩ)	
		-10 to 10V (impedance 1MΩ)	-10 to 10V (impedance 1kΩ)	
		0 to 20mA (impedance 200Ω)	0 to 20mA (impedance 400Ω)	
	4 to 20mA (impedance 200Ω)	4 to 20mA (impedance 400Ω)		
Input/Output Range Switch	Depends on rotary switch settings			
Calibration Function	OFFSET, GAIN Setting (Setting the upper limit)			
Accuracy	0.3% / FS(25°C) 0.5% / FS(0°C to 55°C)			
Insulation Method	Photocoupler insulation (between input terminals and internal circuits)	Photocoupler insulation (between output terminals and internal circuits)		
Processing (after conversion)	Simple Average Running Average Exclude Max./Min values sample data values			
Conversion Timing	Continual conversion of all channels (not selectable)			
Number of Occupied Nodes	4			

\*1 JIS B 3502, IEC61131-2 compliant.  
 - With intermittent vibration: 10 to 57Hz 0.075mm/s<sup>2</sup>, 57 to 150Hz 9.8m/s<sup>2</sup>  
 - With continuous vibration: 10 to 57Hz 0.035mm/s<sup>2</sup>, 57 to 150Hz 4.9m/s<sup>2</sup>  
 Movement in X, Y, Z directions 10 times (for 80 minutes)

Remote I/O (Flex Network) Specifications



Single-axis Positioning Unit



High-speed Counter Unit



Model	FN-PC10SK41	FN-HC10SK41		
Rated Voltage	DC24V			
Rated Voltage Range	DC20.4V to DC28.8V			
Allowable Voltage Drop	10ms or less (for DC24V power supply)			
Power Consumption	4.5W or less	2.5W or less		
In-rush Current	30A or less	15A or less		
Voltage Endurance	AC500V 20mA for 1 min. (combined I/O power and FG terminals)	AC500V 20mA for 1 min. (between I/O and earth terminals)		
Insulation Resistance	DC500V at 10MΩ or higher (combined I/O power and FG terminals)	DC500V at 10MΩ or higher (between I/O and earth terminals)		
Operating Temperature	0°C to 55°C			
Storage Temperature	-25°C to +70°C			
Operating Humidity	30% RH to 95% RH (non-condensing) Level RH-1			
Storage Humidity	30% RH to 95% RH (non-condensing) Level RH-1			
Air Purity (Dust)	0.1mg/m <sup>3</sup> or less (non-conductive levels)			
Corrosive Gases	Free of corrosive gases			
Atmospheric Pressure	800hPa to 1,114 hPa (2,000m or lower)			
Vibration Resistance	+1			
Shock Endurance	IEC61131-2 (JIS B3502) Compliant 147m/s <sup>2</sup> (for 11ms in X,Y,Z directions-2 times each)			
Noise Immunity (via noise simulator)	Noise voltage: 1000Vp-p, Pulse Duration: 1μs, Rise time: 1ns			
Electrostatic Discharge Immunity	Contact discharge of 6kV (IEC 61000-4-2 Level 3)			
Cooling Method	Natural air circulation			
Weight	Approx. 700g (Main unit only) [1.54lb]	Max. 150g [0.33lb]		
External Dimensions	W122mm [4.8in] x H196mm [7.72in] x D35mm [1.38in]	108mm (W) x 49mm (H) x 45mm (D) 4.25in (W) x 1.93in (H) x 1.77in (D)		
Rating	IP30	IP20		
No. of Control Axis	1			
Input Control	Photocoupler Isolation			
Program Method	Sequence program, Teaching loader			
Max. Positioning Memory	90 points (ABS/INC)			
Pulse Output Method	CW/CCW Line Driver Output/Open Collector Output			
Output Frequencies*2	1.5625pps to 62.5kpps/6.25pps to 250kpps/12.5pps to 500kpps/50pps to 2Mpps (set via parameters)			
Max. Pulse Output	+/-2,147,483,647 pulses			
Accelerate/Decelerate Method	Trapezoidal and Sinusoidal curves			
Position Settings	Absolute/Incremental			
Backlash Correction	0 to 65,535 pulses			
Control Mode	Manual, Automatic, Direct			
Origin Point Return	4 Types (option, low-speed, 2 types of high speed)			
Origin Point Correction	-32,767 to 32,767 pulses			
Control Input	Rated Input Voltage	DC24V		
	Maximum Allowable Input Voltage	DC26.4V		
	No. of Input Points	5 points (1 common)		
	Input Impedance	3.9kΩ		
Z Phase Input	Input ON Voltage	DC19V or higher		
	Input OFF Voltage	DC5V or less		
	Input Delay	OFF-ON 1.5ms or less ON-OFF 1.5ms or less		
	Rated Input Voltage	DC5V		
Control Output	Rated Output Voltage	DC24V		
	Maximum Allowable Output Voltage	DC24V (+/-10%)		
	No. of Output Points	1		
	Maximum Load Current	50mA or less		
Open Collector	Voltage Drop (ON Voltage)	DC1.5V or less		
	Clamp Voltage	DC39V +/-1V		
	Current Leakage	0.1mA or less		
	Output Delay Time	OFF-ON 1ms or less ON-OFF 1ms or less		
Line Driver(non-isolated)	Rated Output Voltage	DC5V		
	Rated Output Voltage Range	DC24V (+/-10%)		
	Maximum Allowable Output Voltage	DC4.5V to DC5.5V		
	Output Voltage Drop	DC1.5V or lower		
Differential Output	Output Current	50mA or lower		
	Output OFF-ON Delay	Maximum: 1ms		
	Output ON-OFF Delay	Maximum: 1ms		
	Leakage Current	0.1mA or lower		

\*1 IEC61131  
\*2 Max. speed for open collector output is 100kpps.  
\*3 See User's Manual for each measurement speed.

Remote I/O (Flex Network) Circuit Diagrams



FN-X16TS41 (Sink/Source Input Type)

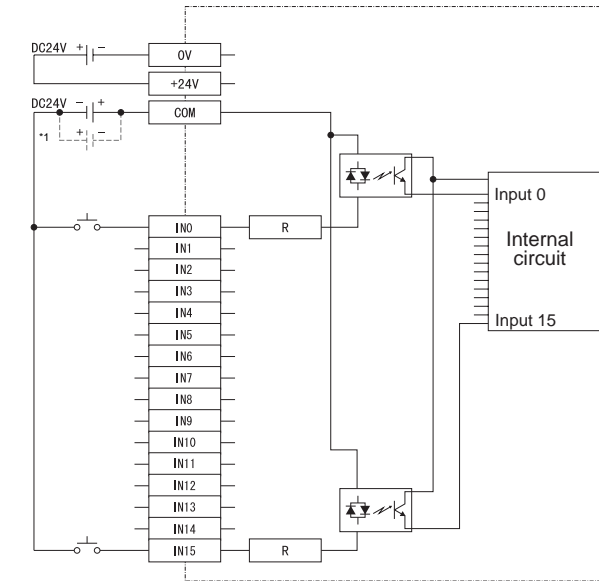

\*1. Dotted line shows the source output type connection.

FN-XY08TS41 (Sink/Source Input & Sink Output Type)

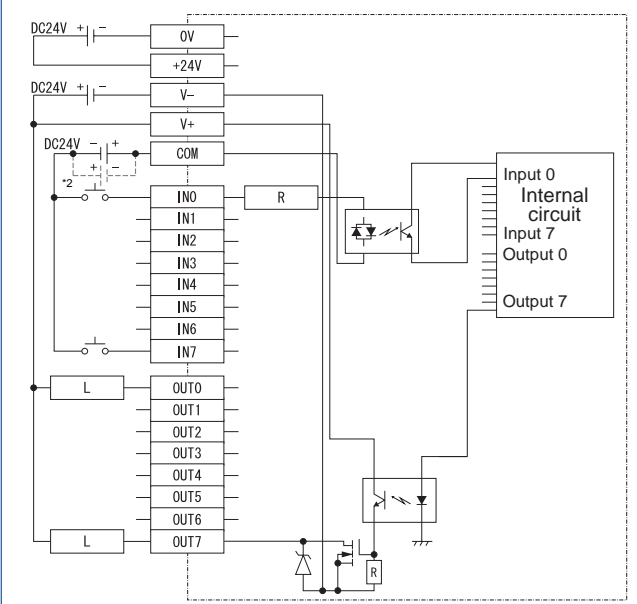

\*2. Dotted line shows the source output type connection.

FN-Y08RL41 (Relay Output Type)

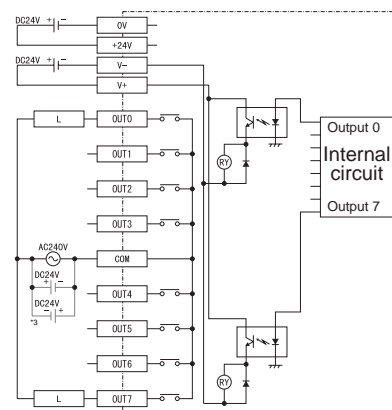

\*3. The relay specifications can change the COM power supply.

FN-Y16SK41 (Sink Output Type)

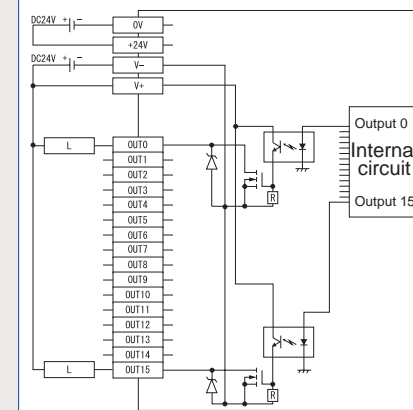

FN-Y16SC41 (Source Output Type)

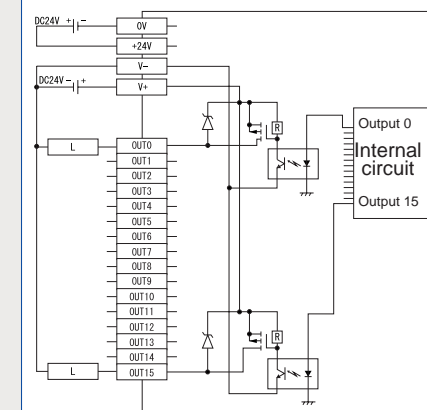

**FN-X32TS41**  
(Sink/Source Input Type)

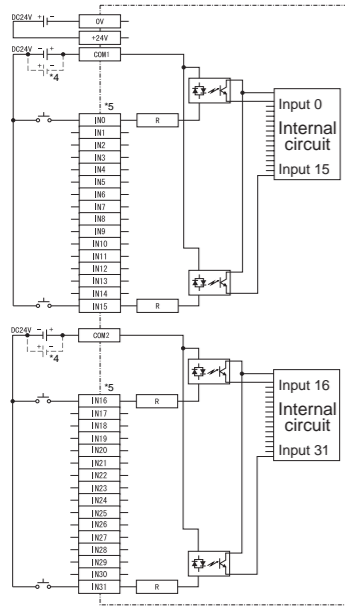

\*4. Dotted line shows the source type connection.  
\*5. For IN0 to IN15, use COM1. For IN16 to IN31, use COM2 as the input common.

**FN-XY16SK41**  
(Sink/Source Input & Sink Output Type)

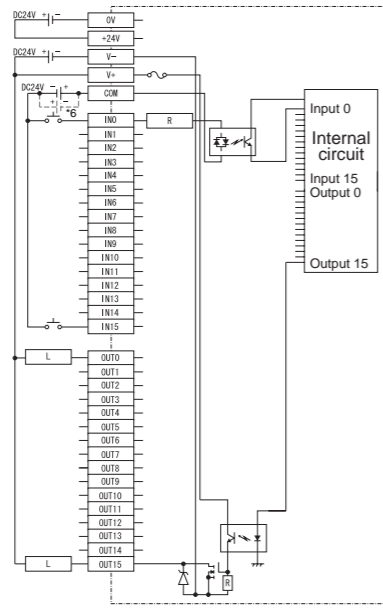

\*6. Dotted line shows the source type connection.

**FN-XY16SC41**  
(Sink/Source Input & Source Output Type)

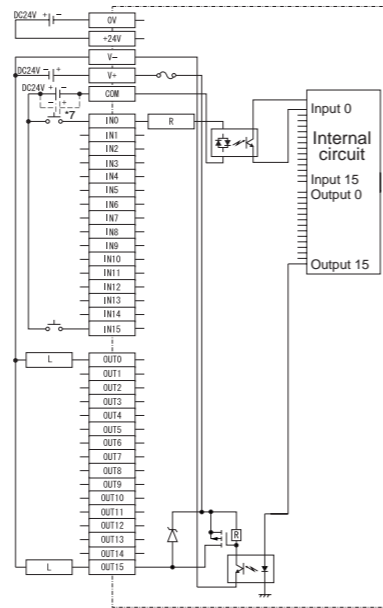

\*7. Dotted line shows the sink type connection.

**FN-XY32SKS41**  
(Sink/Source Input & Sink Output Type)

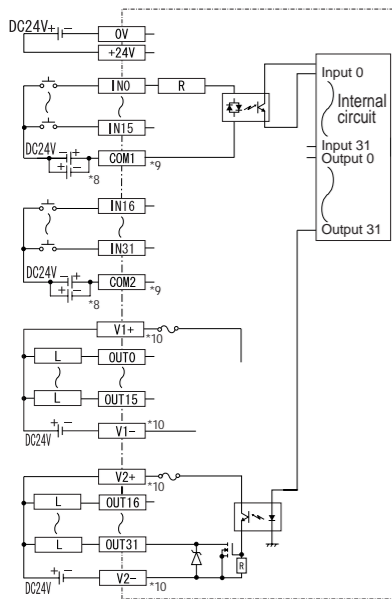

\*8. Dotted line shows the source type connection.  
\*9. For IN0 to IN15, use COM1. For IN16 to IN31, use COM2 as the input common.  
\*10. For OUT0 to OUT15, connect the output power to V1+/V1-. For OUT16 to OUT31, connect the output power to V2+/V2-.

**FN-AD04AH11**  
(Input Section Circuit Diagram)

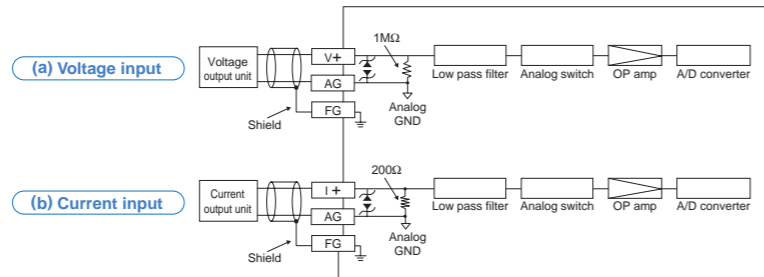

**FN-DA04AH11**  
(Output Section Circuit Diagram)

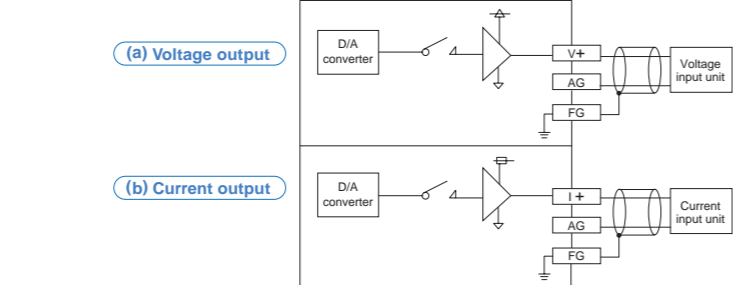

**Remote I/O (Flex Network) Circuit Diagrams**



**FN-PC10SK41**  
(Single-axis Positioning Unit)

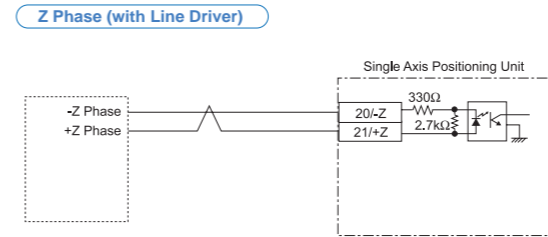
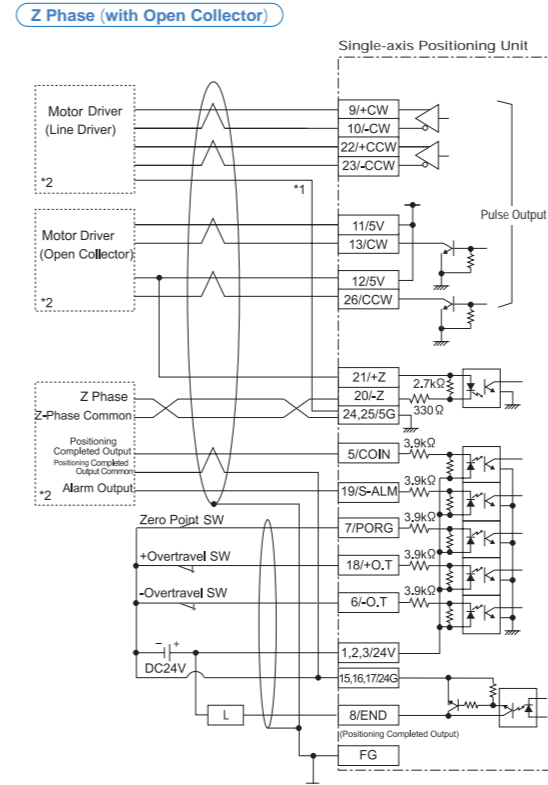

**FN-HC10SK41**  
(High-speed Counter Unit)

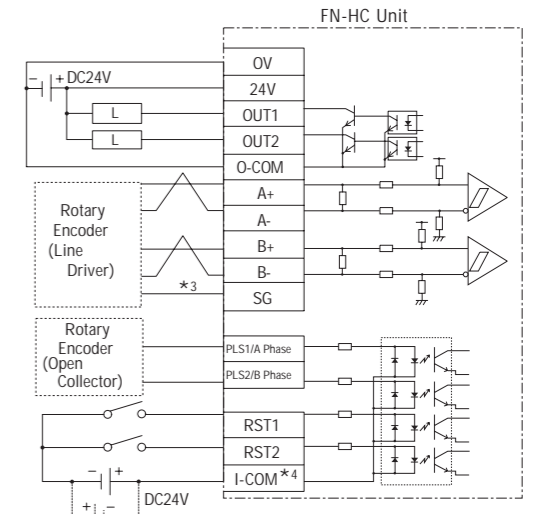

\*1 The FN-PC unit's live line is not isolated. If it is connected to a non-isolated servo driver, be sure to connect the signal ground (5G) to prevent over-current damage.  
\*2 For motor driver connection details, refer to User's manual.  
\*3 The FN-HC unit's input line is not isolated. When connecting this unit to a line driver that is not isolated, be sure to connect the signal ground (SG) terminal.  
\*4 The Input Common (I-COM) shown here is connected to a Sink Output type. (The dotted line shows the connection with a Source Output type.)

**Remote I/O System (Flex Network)**

Flexible support for adding/modifying I/O points!

Supports up to 63 nodes  
1008 I/O points

6Mbps/12Mbps high-speed remote I/O lets you use remote equipment without remote equipment performance. Connect up to 1008 I/O points and attain communications lag time of only 0.94ms (at 512 points/12Mbps). Extensions up to 400m (with 6Mbps x 2 channels).  
\* 256-point: 944µsec/472µsec response speed at 6Mbps/12Mbps communications speed.

**High Speed 6Mbps/12Mbps**

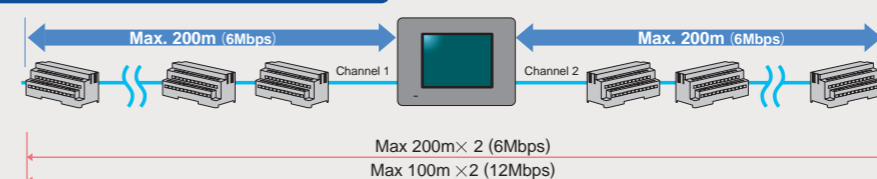

\* Use special cables capable of stable high-speed communications when connecting Flex Network units.

**International Safety Standards**

Model numbers ending in '41' comply with the following standards.



# Smooth system integration of Pro-face products is assured with a total support network.

## WORLDWIDE SUPPORT



Pro-face regional offices and partners offer technical support and repair services around the world. Contact your local Pro-face office for more information about support services available.

ACCESS!!!

[www.pro-face.com](http://www.pro-face.com)

### Worldwide Contacts:

General Info: [info@pro-face.com](mailto:info@pro-face.com)

Technical Info: [support@proface.co.jp](mailto:support@proface.co.jp)

### Conformity with International Safety Standards

Pro-face products and component parts bearing the CE Mark and the UL or C-UL Listing and Recognized Component Marks are your guarantees of compliance with safety standards accepted in countries and regions worldwide.



**Caution:** Before operating any of these products, please be sure to read all related manuals thoroughly.

- For printing purposes, the colors in this catalog may differ from those of the actual unit.
- Actual user screens may differ from the screens shown here.
- LCD screens may exhibit minute grid-points (light and dark) on the Display Panel surface or Also, "Contouring" - where some parts of the screen are brighter than others, producing a wavelike pattern - may occasionally occur. Both are normal for an LCD display and are not defects.

- Microsoft® Excel, Access are registered trademarks of Microsoft Corporation.
- All product names used in this catalog are the registered trademarks of their respective companies.
- All information contained in this catalog is subject to change without notice.

©2004 Digital Electronics Corporation All Rights Reserved.

#### Global Head Office

Digital Electronics Corporation  
8-2-52 Nanko-higashi  
Suminoe-ku, Osaka 559-0031  
JAPAN  
Tel: +81-(0)6-6613-3116  
Fax: +81-(0)6-6613-5888  
<http://www.pro-face.com>  
[info@pro-face.com](mailto:info@pro-face.com)

#### Asia Pacific Regional Office

Digital Electronics Corporation  
Bangkok Representative Office  
2034/52 (11-07/4), 11th floor  
Italthai Tower,  
New Phetchburi Road  
Bangkapi, Huaykwang,  
Bangkok 10320  
THAILAND  
Tel: +66-(0)2-716-1733  
Fax: +66-(0)2-716-1737

#### Scandinavia

Pro-face Scandinavia ApS  
Copenhagen Vallensbækvej 18A  
DK-2605 Brøndby  
DENMARK  
Tel: +45 70 22 01 22  
Fax: +45 70 22 01 33  
<http://www.pro-face.dk>  
[info@pro-face.dk](mailto:info@pro-face.dk)

#### Italy

Pro-face Italia S.p.a.  
Via G. di Vittorio 26  
20030 Bovisio Masciago (Milano)  
ITALY  
Tel: +39 0362 59 96 1  
Fax: +39 0362 59 96  
<http://www.proface.it>  
[info.Italia@proface.it](mailto:info.Italia@proface.it)

#### China

Wuxi Pro-face Electronics Co., Ltd.  
Shanghai Office  
Room 2001, Singluar Mansion  
No.322, Xian Xia Road  
Shanghai 200336  
P. R. CHINA  
Tel: +86-(0)21-6208-6367  
Fax: +86-(0)21-6208-4816  
<http://www.proface.com.cn>  
[proface@proface.com.cn](mailto:proface@proface.com.cn)

#### North/South American Head Office

Pro-face America, Inc. / Xycorn  
750 North Maple Road  
Saline, MI 48176-1292  
U.S.A.  
Tel: +1-734-429-4971  
Fax: +1-734-429-1010  
<http://www.profaceamerica.com>  
[sales.info@profaceamerica.com](mailto:sales.info@profaceamerica.com)

#### Sweden

Pro-face Sweden AB  
Malmö Amiralsgatan 20  
SE-211 55 Malmö  
SWEDEN  
Tel: +46 (0)40 660 19 55  
Fax: +46 (0)40 660 19 40  
<http://www.pro-face.dk>  
[info@pro-face.dk](mailto:info@pro-face.dk)

#### United Kingdom

Pro-face UK Ltd  
Pro-face House 8 Orchard Court  
Binley Business Park Coventry CV3 2TQ  
ENGLAND  
Tel: +44 (0)2476 440088  
Fax: +44 (0)2476 440099  
<http://www.profaceuk.com>  
[info@profaceuk.com](mailto:info@profaceuk.com)

#### South Korea

Pro-face Korea Co., Ltd.  
4th floor, Cheil Bldg. 94-46  
Youngdeungpo-Dong 7Ka,  
Youngdeungpo-Ku Seoul 150-037  
SOUTH KOREA  
Tel: +82-(0)2-2630-9850  
Fax: +82-(0)2-2630-9860  
Support Center (A/S Center)  
Tel: +82-(0)31-940-3713  
Fax: +82-(0)31-940-3780  
<http://www.proface.co.kr>  
[proface@proface.co.kr](mailto:proface@proface.co.kr)

#### European Head Office

Pro-face Europe B.V.  
Jadelaan 34-36 2132 XW Hoofddorp  
THE NETHERLANDS  
Tel: +31 (0)23 55 44 099  
Fax: +31 (0)23 55 44 090  
<http://www.proface.com>  
[info@proface.com](mailto:info@proface.com)

#### Germany

Pro-face Deutschland GmbH  
Albertus-Magnus-Straße 11  
42719 Solingen  
GERMANY  
Tel: +49 (0)212 258 260  
Fax: +49 (0)212 258 2640  
<http://www.pro-face.de>  
[sales@pro-face.de](mailto:sales@pro-face.de)

#### Spain and Portugal

Pro-face España  
Apartado de Correos No 62  
E-08440 Cardedeu Barcelona  
SPAIN  
Tel: +34 (0)93 846 07 45  
Fax: +34 (0)93 845 48 68  
<http://www.pro-face.es>  
[central@pro-face.es](mailto:central@pro-face.es)

#### Taiwan

Pro-face Taiwan Co., Ltd.  
4F, No. 77, Section 3, Nanjing East Road  
Taipei 104  
TAIWAN R.O.C.  
Tel: +886-(0)2-2507-1102  
Fax: +886-(0)2-2507-1104  
<http://www.proface.com.tw>  
[proface@proface.com.tw](mailto:proface@proface.com.tw)

#### France

Pro-face France S.A.S.  
Le Vinci 7  
1, rue Henri Becquerel  
77290 Mityry-Mory  
FRANCE  
Tel: +33 (0)1 60 21 22 91  
Fax: +33 (0)1 60 21 22 92  
<http://www.proface.fr>  
[info@proface.fr](mailto:info@proface.fr)

#### Switzerland

Pro-face Deutschland GmbH  
Niederlassung Schweiz  
Krummbuckweg 6  
8157 Dielsdorf  
SWITZERLAND  
Tel: +41 (0)1 8853322  
Fax: +41 (0)1 8853330  
<http://www.pro-face.ch>  
[info@pro-face.ch](mailto:info@pro-face.ch)