

# 12.1" Panel Computer - PS3650A-T42/T42S Series



**Features:**

- 12.1-inch (XGA 1024x768) TFT Touch Panel Computer
- Intel® Celeron® M 1.5 GHz
- 250GB Hard Drive, 2 or 8GB CF Drive, 16-128 GB SSD (Solid State Drive)
- Windows XP Pro or Windows XP Embedded
- Integrated Factory Alert System with Output Port\*1
- NEMA 4/4x/12 Rated
- SSD (Solid State Drive) for reliability and faster data access

• RoHS Directive-conforming

- **On-demand HMI WinGP Option**
- Use PC as On-demand Touch Screen HMI
- Allows 3rd Party Applications to Run Concurrently:
  - SPC, Vision, SCADA, MRP
- Expands PC Hardware and Data Connectivity Options

**Performance Specifications**

Model	PS3650A-T42/T42S Series - Build to order (See reverse side for ordering information)	
Supported OS	Windows® XP Multi-language (XM250, XM16SA, XM32SA, XM64SA, XM128SA), Windows® XP Pro* (XPC08) (*This version of XP Pro includes English, French, Spanish, Brazilian Portuguese, Japanese, Simplified and Traditional Chinese Languages), Windows® XP Embedded Multi-language (EM2G)	
CPU	Intel® Celeron® M 1.5 GHz	
Standard Memory	1 GB SO-DIMM	
Maximum Memory	1 Slot (Max. 1 GB) SO-DIMM socket (PC2700)	
Graphics Display Resolution	XGA (1024 x 768 dots)	
Video Memory	Max. 64 MB (When using Windows®) UMA Type	
Display Type and Size	TFT Color LCD (12 inch)	
Display Colors	262,144 Colors	
Display Area	W 245.76mm [9.68in.] x H 184.32mm [7.26in.]	
Touch Screen	Resistive Film (Analog)	
Serial	<PS3650A-T42> COM1: RS 232C, D-sub 9 pin (plug) (422 / 485, RI/+5V switchable) COM2: None	<PS3650A-T42S> COM1: RS 232C, D-sub 9 pin (plug) (422 / 485, RI/+5V switchable) COM2: RS 232C, D-sub 9 pin (plug) (RI/+5V switchable)
LAN	Rear 2 ports. RJ-45 type modular jack connector (8 pins) LAN1: auto change to 10BASE-T/100BASE-TX LAN2: auto change to 10BASE-T/100BASE-TX/100BASE-T (Supports Wake-On LAN)	
USB	USB 2.0 compatible side 4 ports. Disable by hardware setting. USB 1.1 front face port	
Sound	Stereo speaker output, rear 1 port (3.5mm jack)	
Disk	IDE I/F, Master: 2.5 inch 250GB HDD. or 80-160GB SSD Slave: CF Card I/F (not hot-swappable). Switchable to Master by hardware setting.	
PCMCIA	1 Port PCMCIA Type II. Corresponding to CARD BUS (Excluding Zoomed Video, SOUND functions)	
PCI	Rev.2.2 compatible PCI I/F (5V) 1 Port Slot Length: Depth 174.63mm[6.88in.] x Height 106.68mm[4.2in.]	
RAS	<PS3650A-T42> D-Sub, 9-Pin Socket 1 port	<PS3650A-T42S>*1 None

\*1 Factory Alert System is equipped without RAS port

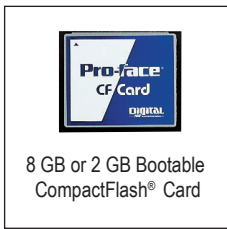

12.1-inch TFT Color LCD Panel Computer

AC100-240V

24VDC

XGA

**12.1** -inch

**PS-3650TA**

Models: PS3650-T42/T42S Series,  
CPU: Intel Celeron M 1.5 GHz

All-in-one model

Windows® XP

Factory Alert System

Windows® XP Embedded

SSD

WinGP

CF Card



**General Specifications**

Model Numbers	PS3650A-T42/T42S Series (AC Models),	PS3650A-T42/T42S-24V Series (DC Models)
Input Voltage	AC100 / 240V (Rated Voltage AC85 to 264V)	24V DC (Rated Voltage DC19.2 to 28.8V)
Power Consumption	110VA or less	80W or less
Allowable Voltage Drop	1 cycle or less (Voltage drop interval must be 1s or more.)	5ms or less
Voltage Endurance	AC1500V 20mA for 1 minute (between charging and FG terminals)	AC1000V 20mA for 1 minute (between charging and FG terminals)
Insulation Resistance	DC500V 10MΩ(min.) (between charging and FG terminals)	
Certification	UL508, CSA-C22.2 No.142-M1987, CE (EN55011 Class A, EN61000-6-2, EN60950-1), RoHS	UL508, CSA-C22.2 No.142-M1987, CE (EN55011 Class A, EN61000-6-2), RoHS
Temperature	0 to 50°C (32 to 122°F) without HDD; 5 to 50°C (41 to 122°F) with HDD / Storage Temperature -20 to +60°C (-4 to 140°F)	
Humidity - Ambient/Storage	10 to 90% RH (Not condensing, wet bulb temperature: 29°C (84.2°F) or less). / Storage Humidity 10 to 90% RH (Not condensing, wet bulb temperature: 39°C (102.2°F) or less).	
Corrosive Gas	Free of corrosive gases	
Noise Immunity	Noise Voltage: 1500Vp-p, Pulse Duration: 50ns, 500ns, 1µs, Rise Time: 1ns (via noise simulator)	Noise Voltage: 1000Vp-p, Pulse Duration: 50ns, 500ns, 1µs Rise Time: 1ns (via noise simulator)
Cooling Method	Forced Air Cooling by Fan	
Electrostatic Discharge Immunity	6kV (complies with EN 61000-4-2 Level 3)	
Vibration Resistance	Without HDD - IEC61131-2 compliant. 5 to 9Hz single-amplitude 3.5mm, 9 to 150Hz constant-accelerated velocity 9.8m/s <sup>2</sup> . X, Y, Z directions for 10 cycle (100 minutes) With HDD - 10 to 57 Hz Single amplitude: 0.0375 mm (0.003in) 57 to 150 Hz Fixed acceleration: 4.9m/s <sup>2</sup> . X, Y, Z directions for 10 cycle (80 minutes)	
Rating	Equivalent to IP65f NEMA #250 TYPE 4/4X/12. (Not using front USB)	
Weight	Approx. 4.5kg [9.9lb] (unit only)	
External Dimensions	313mm [12.32in.] W × 239mm [9.41in.] H × 103mm [4.06in.] D	
Warranty	Two (2) year	

**PS-3650A - External Dimensions**

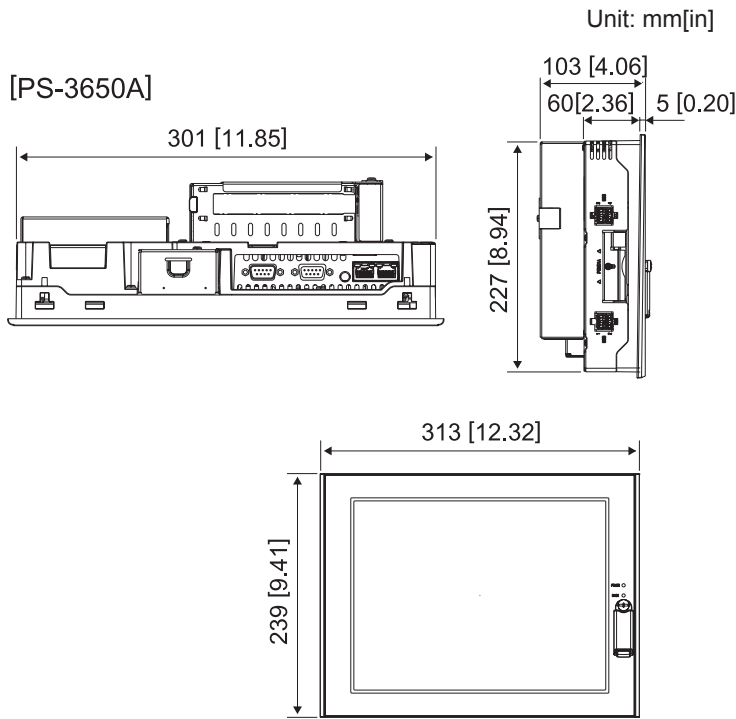

**Ordering Information**

**PS3650A-T42 - - 1G - - -**

Serial port \_\_\_\_\_  
Blank...1 Port  
S.....2 Ports

Power Supply: \_\_\_\_\_  
Blank....AC  
24V.....DC

Operating System: \_\_\_\_\_  
XM250....250 GB HDD w/ XP ML  
EM2G...2 GB CF w/ XPe ML  
XPC08..8 GB CF w/ XP Pro\*  
XMSSDSA..80GB SSDw/XP ML  
XMHSDSA..160GB SSDw/XP ML

Secondary Storage \_\_\_\_\_  
Blank.....No Secondary Storage  
NO250.....250GB HDD  
NOSSDSA..80GB SSD  
NOHSDSA..160GB SSD

Open HMI: \_\_\_\_\_  
Blank....No HMI Software Included  
WG.....WinGP Installed

\* The languages included with this version of Windows XP Pro are English, French, Spanish, Brazilian Portuguese, Japanese, Simplified and Traditional Chinese

**Optional Items**

Product Name	Part Number	
SO-DIMM Memory	1 GB	PSA-DDR1G
HDD Unit *2	250 GB	PS365XA-HD250
CF Card *2	512MB	CA3-CFCALL/512MB-01
	1GB	CA6-CFCALL/1GB-01
	2GB	CA8-CFCALL/2GB-01
	8GB	150638 *3
Installation Gasket*1	CA3-WPG12-01	
Installation Fasteners *1	CA3-ATFALL-01	
Backlight (2 pieces/set for 1 unit)	CA8-BLU12XGA-01	
Screen Protection Sheet (5 sheets/set)	CA5-DFS10-01	

\*1 Standard attachment for all models. \*2 Not installed with operating system. \*3 Must be slave if used with another IDE device, otherwise set as master

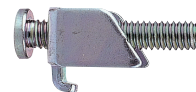

Installation Fasteners



CF Card

**PS-3650A - Cut-Out Dimensions**

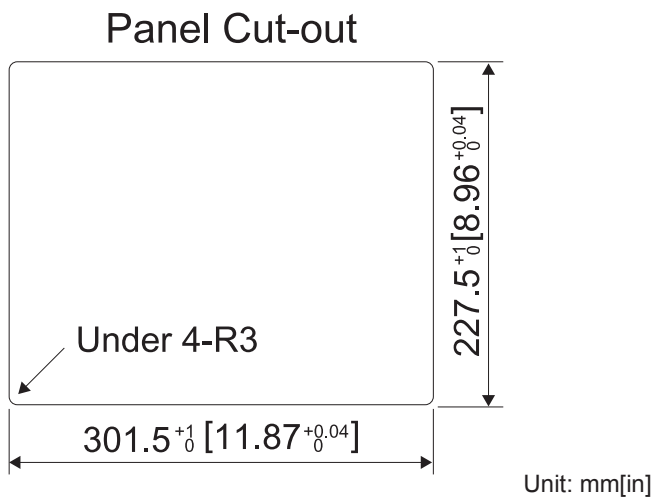

**Pro-face America**  
Phone: 734.477.0060  
Fax: 734.864.7347  
www.profaceamerica.com

**Customer Service Hotline: 734.944.0482**

For more information  
**ACCESS** [www.profaceamerica.com](http://www.profaceamerica.com)

**Pro-face**  
for the best interface



# California Proposition 65 Warning—Lead and Lead Compounds

## Advertencia de la Proposición 65 de California—Plomo y compuestos de plomo

## Avertissement concernant la Proposition 65 de Californie—Plomb et composés de plomb

**⚠ WARNING:** This product can expose you to chemicals including lead and lead compounds, which are known to the State of California to cause cancer and birth defects or other reproductive harm. For more information go to: [www.P65Warnings.ca.gov](http://www.P65Warnings.ca.gov).

**⚠ ADVERTENCIA:** Este producto puede exponerle a químicos incluyendo plomo y compuestos de plomo, que es (son) conocido(s) por el Estado de California como causante(s) de cáncer y defectos de nacimiento u otros daños reproductivos. Para mayor información, visite : [www.P65Warnings.ca.gov](http://www.P65Warnings.ca.gov).

**⚠ AVERTISSEMENT:** Ce produit peut vous exposer à des agents chimiques, y compris plomb et composés de plomb, identifiés par l'État de Californie comme pouvant causer le cancer et des malformations congénitales ou autres troubles de l'appareil reproducteur. Pour de plus amples informations, prière de consulter: [www.P65Warnings.ca.gov](http://www.P65Warnings.ca.gov).

All trademarks are the property of Schneider Electric SE, its subsidiaries, and affiliated companies.

**Schneider Electric USA, Inc.**  
800 Federal Street  
Andover, MA 01810 USA  
888-778-2733  
[www.schneider-electric.us](http://www.schneider-electric.us)

Todas las marcas comerciales son propiedad de Schneider Electric SE, sus filiales y compañías afiliadas.

Importado en México por:  
**Schneider Electric México, S.A. de C.V.**  
Av. Ejercito Nacional No. 904  
Col. Palmas, Polanco 11560 México, D.F.  
55-5804-5000  
[www.schneider-electric.com.mx](http://www.schneider-electric.com.mx)

Toutes les marques commerciales sont la propriété de Schneider Electric SE, ses filiales et compagnies affiliées.

**Schneider Electric Canada, Inc.**  
5985 McLaughlin Road  
Mississauga, ON L5R 1B8 Canada  
800-565-6699  
[www.schneider-electric.ca](http://www.schneider-electric.ca)