

PS5700T Performance Modular Industrial PC

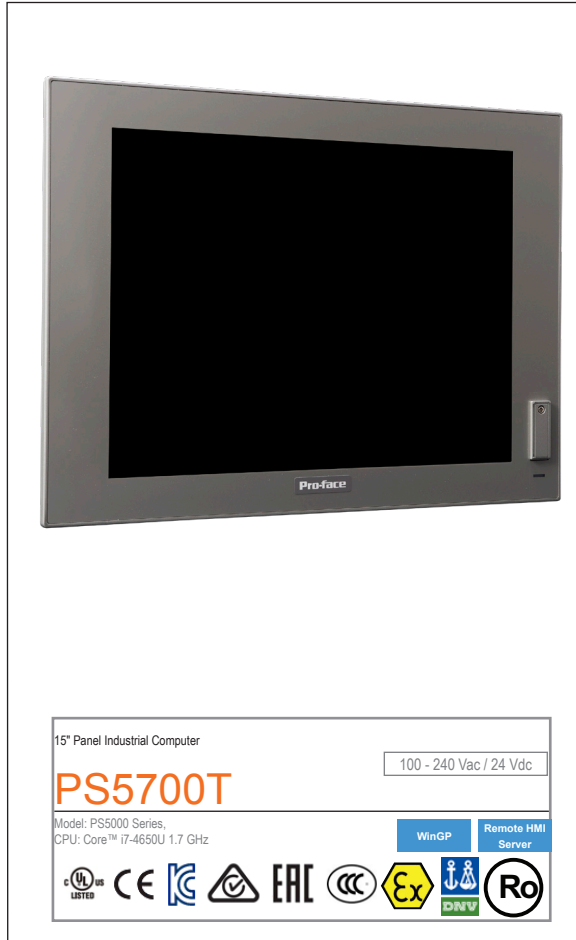

Features:

- Core™ i7-4650U 1.7 GHz
- Fan-less Design
- Extensive Connectivity
- Modular Flexible Design
- TFT Color LCD Display
- VESA Mounting Options

Performance Specifications

Models	PS5000 Series (Build to Order)	
Graphics Display Resolution	XGA TFT (1,024 x 768 pixels)	
Display Type & Size	TFT Color LCD (15-inch) (4:3)	
Display Colors	16.7 Million	
Touch Panel	Resistive single touch	
Panel Resolution	2048 x 2048	
Graphic Accelerator	Intel HD Graphics 5000	
Supported OS	Windows® 7 Ultimate 64 bit MUI / Windows® Embedded Standard 7 (Premium) 64 bit MUI / Windows® Embedded 8.1 Industry 64 bit MUI, WES Win7 32bit En MUI, Windows 10 IoT Enterprise 64bit MUI	
CPU	Core™ i7-4650U 1.7 GHz	
Main Memory	8 GB / 16 GB, DDR3L 1600 MHz, SO-DIMM SDRAM 512 KB MRAM for the user	
Video Memory	Up to 1.7 GB, Shared system memory	
Interfaces	Serial ATA	HDD / SSD x 2 *1 CFast x 1 mSATA x 1
	Serial (COM1)	RS-232C / 422 / 485 (D-Sub 9-pin, plug)
	Ethernet (LAN1)	10/100/1000 Mbit/s (RJ-45 Modular jack)
	Ethernet (LAN2)	10/100/1000 Mbit/s (RJ-45 Modular jack)
	USB	USB 3.0 x 2, USB 2.0 x 2, USB 2.0 (front) (Type A)
	Video	DisplayPort (Type A) x 1
	Mini PCIe	x 2 (revision 1.2)
	Expansion Slot *2	PCIe (x4) x 2 / PCI x 2 / PCI x 1 + PCIe (x4) x 1

*1 When installed, an optional disk adapter unit (PFXPBADHDD2) that is separately sold is required. *2 2 slot model only.

General Specifications

Models	PS5000 Series (Build to Order)
Input Voltage	DC Power Model: 24 Vdc ±20 % When using AC power supply unit: 100 to 240 Vac *3
Power Consumption	25.9 W (Max. 44.9 W)
In-Rush Current	8.9 A
Storage Temperature	-30 to 70° [-22 to 158°]
Concussion Resistance	IEC60068-2-27 Ea Test
Certifications	CE (EN61000-6-4, EN61000-6-2, EN61131-2), CSA/UL61010, ATEX, Marine (DNV), RCM (C-Tick), EAC (GOST-R), RoHS, REACH, CCC, KC, WEEE
Surrounding Air Temperature	When using SSD / CFast running: 0 to 55° [32 to 131°] When using HDD running: 0 to 45° [32 to 113°] When using mPCI x 2 + Display module : 0 to 45° [32 to 113°] When using PCI/PCIe : 0 to 45° [32 to 113°]
Ambient/Storage Humidity	10 to 95 % RH (Wet bulb temperature: 40 °C [104 °F] max. - no condensation)
Pollution Degree	For use in pollution degree 2 environment
Installation Configuration	Panel Mounting or VESA mounting with optional kit *4
Cooling method	Passive heat sink *5
Air Pressure (altitude range)	2,000 m (6,560 ft) max
Vibration Resistance	Operation for products with SSD or CF card storage device: 5 to 500 Hz: 2 Grms Operation for products with HDD storage device: 5 to 500 Hz: 1 Grms
Electromagnetic Compatibility	Immunity to High Frequency Interference.Electromagnetic Emissions Class A
Structure	IP66 (front side of display)
Weight	0 slot: 7.3 kg (16 lbs.) 2 slot: 8.1 kg (17.8 lbs.)
External Dimensions	0 slot: W390.7 x H290.0 x D93.2 mm [W15.38 x H11.42 x D3.67 in.] 2 slot: W390.7 x H290.0 x D131.2 mm [W15.38 x H11.42 x D5.16 in.]
Panel Cut-Out Dimensions	W383.5 x H282.5 mm [W15.09 x H11.12 in.]
Warranty	Two (2) years

*3 For use at 100 to 240 Vac, an optional AC power adapter (PFXPBPUAC2) that is separately sold is required. *4 VESA mounting kit sold separately is required, 0 slot: PFXPBADVS02, 2 slot: PFXPBADVS22 *5 The operating temperature is limited to 45 C and the cooling fan is required for PCI/PCIe cards installed on board with power consumption from 3W to 6W max. for two cards or 10W max for one card.

External Dimensions

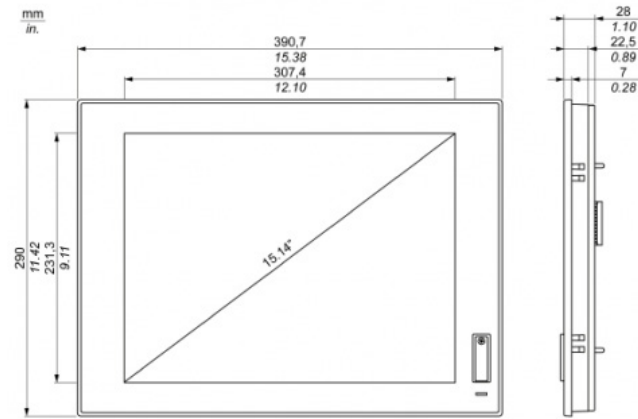

Panel Cut Dimensions

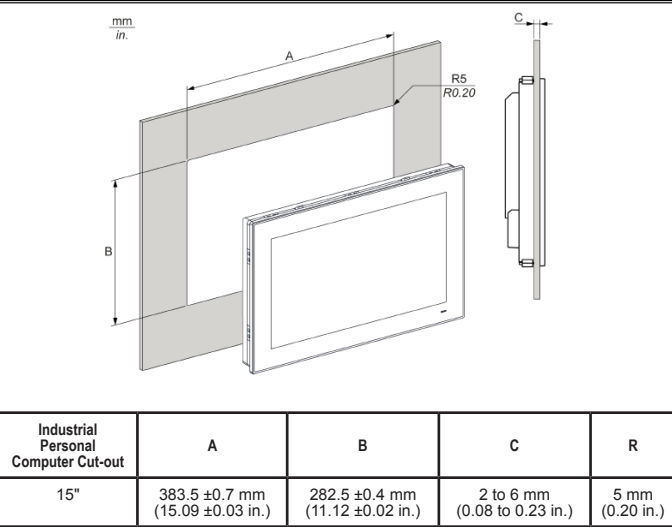

In addition to the wide variety of standard interfaces, additional interface options allow for extensive connectivity and product expansion.



See profaceamerica.com for optional accessories.

Ordering Information

PS5700T-i7-***

Panel PC and Modular Displays	700T: Modular Display 15"
Box PC	i7-16G: Box PC Core i7 16GB (1xDP, 2xEth., 1xCOM, 4xUSB, MRAM)
	i7-16G-1P1E: Box PC Core i7 16GB 1 PCI + 1 PCIe (1xDP, 2xEth., 1xCOM, 4xUSB, MRAM)
	i7-16G-2P: Box PC Core i7 16GB 2 PCI (1xDP, 2xEth., 1xCOM, 4xUSB, MRAM)
	i7-16G-2E: Box PC Core i7 16GB 2 PCIe (1xDP, 2xEth., 1xCOM, 4xUSB, MRAM)
	i7-16G-CC: Box PC Core i7 16GB Conformal Coating (1xDP, 2xEth., 1xCOM, 4xUSB, MRAM)
	i7-16G-1P1E-CC: Box PC Core i7 16GB 1 PCI + 1 PCIe Conformal Coating (1xDP, 2xEth., 1xCOM, 4xUSB, MRAM)
CPU Fan Kit	None F: CPU Fan Kit for expansion cards above 3W
Power Supply	D: 24 VDC A: 100 - 240 AC
Operating System	None WES7: WES7 Premium SP1 64bit En MUI W764: Win7 Ultimate FES SP1 64bit En MUI WE8: Win8.1 Industry 64bit En MUI WS732: WES Win7 32bit En MUI W1064I: Windows 10 IoT Enterprise 64bit MUI (i7)
Main Storage Device	None CF32: CFast 32GB SHD: HDD 500GB HHD: HDD 1TB SSD8: SSD 80GB SSD24: SSD 240GB
Optional Interfaces	None 485X2: Interface - RS485 x 2 Isolated 485X4: Interface - 4 x RS422/485 USBX2: Interface - 2 x USB 3.0 232X2: Interface - 2 x RS232 Isolated 232X4: Interface - 4 x RS232 IO: Interface - 16DI / 8DO AU: Interface - Audio CL: Interface - 1x GPRS/GSM ETH: Interface - Gigabit IEEE 1588 Lan CO: Interface - 2x CanOpen CanBus PF: Interface - Profibus DP Master with NVRAM LANX2: Interface - 2x PoE LAN DVII: Interface - DVI-I VGAX2: Interface - 2 x VGA DVID: Interface - DVI-D ECAT: Interface - EtherCAT DVIDVGAX2: Interface - DVI-D + 2 X VGA
Secondary Storage	None CF32: CFast 32GB SHD: HDD 500GB HHD: HDD 1TB SSD8: SSD 80GB SSD24: SSD 240GB
Software	None WGP: WinGP HMIS: Remote HMI Server WGPHMIS: WinGP + Remote HMI Server OPN15: BLUE Open Studio Runtime 1.5K tags OPN32: BLUE Open Studio Runtime 32K tags OPN40: BLUE Open Studio Runtime 4K tags OPN64: BLUE Open Studio Runtime 64K tags
Extended Warranty	None (2 year standard) One year extended Two year extended