

PS5711W Industrial PC



Features:

- Core™ i3-4010U 1.7 GHz
- Fan-less Design
- IP66 Compliance
- Extensive Connectivity
- Multi-touch display
- Slim Versatile Design
- TFT Color LCD Display
- Power Consumption: 60W (max.)

Performance Specifications

Models	PS5700 Series- Build to order (See reverse side for ordering information)	
Graphics Display Resolution	FWXGA TFT (1,366 x 768 pixels)	
Display Type and Size	TFT Color LCD (15.6-inch)	
Display Colors	16.7 Million	
Touch Panel	Multi-touch (5 point simultaneous touch) projected capacitive	
Supported OS	Windows® 7 Ultimate 64 bit MUI Windows® Embedded Standard 7 32bit En MUI Windows® Embedded Standard 7 (WES7P) 64 bit MUI Windows® Embedded 8.1 Industry 64 bit MUI Windows® 10 IoT Enterprise 64bit MUI (i3)	
CPU	Core™ i3-4010U 1.7 GHz	
Main Memory	DDR3 : 8 GB	
Video Memory	Up to 1.7 GB	
Interfaces	Serial (COM1)	RS-232C (D-Sub 9-pin, plug)
	Serial (COM2)	RS-232C / 422 / 485 (D-Sub 9-pin, plug)
	Ethernet (LAN1)	10/100/1000 Mbit/s (RJ-45 Modular jack)
	Ethernet (LAN2)	10/100/1000 Mbit/s (RJ-45 Modular jack)
	USB (TYPE-A)	USB 3.0 x 2 (Type A)
	Video Output	HDMI x 1

General Specifications

Models	PS5711W (Build to Order)
Input Voltage	AC Power Model: 100 to 240 Vac, DC Power Model: 24 Vdc ±20 % *1
Power Consumption	18 W (Max. 60 W)
In-Rush Current	7 A
Storage Temperature	- 20 to +60 °C (- 4 to +140 °F)
Operating Temperature	0...55 °C (32...131 ° F) with SSD or CFast, 0...45 °C (32...113 ° F) with HDD
Certifications	UL 60950 and CSA 60950, Industrial Control Equipment CCC, RCM and EAC or GOST-R certification .Australia: - I Standard AS/NZS CISPR11 (C-Tick), (RCM)
Surrounding Air Temperature	When using SSD / CFast running: 0 to 55°C [32 to 131 °F] When using HDD running: 0 to 45 °C [32 to 113 °F]
Ambient/Storage Humidity	10 to 95 % RH (Wet bulb temperature: 40 °C [104 °F] max. - no condensation)
Corrosive Gas	Free of corrosive gases
Air Pressure (altitude range)	2,000 m (6,560 ft) max
Vibration Resistance	Operation for products with SSD or CF card storage device: 5 to 500 Hz: 2 Grms Operation for products with HDD storage device: 5 to 500 Hz: 1 Grms
Electromagnetic Compatibility	Immunity to High Frequency Interference.Electromagnetic Emissions Class A
Structure	IP66
Weight	6.0 kg [13.22 lb]
External Dimensions	W419.7 x H269.0 x D56.7 mm [W16.52 x H10.59 x D2.23 in.]
Panel Cut-Out Dimensions	W412.4 x H261.7 mm [W16.24 x H10.30 in.]
Warranty	Two (2) years

*1 For use at 100 to 240 Vac, an optional AC/DC power adapter (PFXZPSPUAC3) that is separately sold is required.

External Dimensions

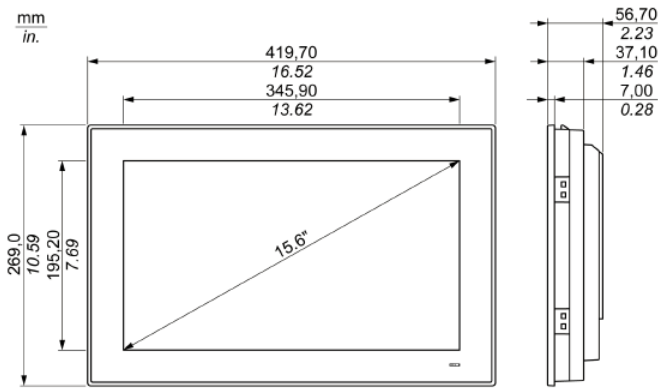

Panel Cut Dimensions

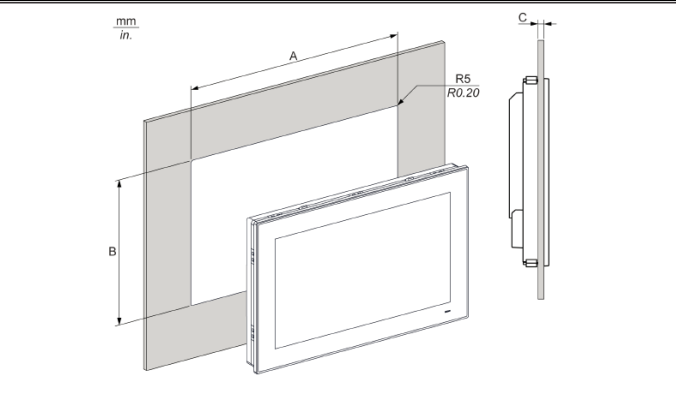

Industrial Personal Computer Cut-out	A	B	C	R
15" Wide	412.4 ±0.7 mm (16.24 ±0.03 in.)	261.7 ±0.4 mm (10.30 ±0.02 in.)	2 to 6 mm (0.08 to 0.23 in.)	5 mm (0.20 in.)

Optional Items

Part Number	Description
PFXZPPDSP152	Screen Protection Sheet for 15.6" (5 pcs)
PFXZPBCNDC2	DC Power Supply Connector (5 pcs)
PFXZPPWG152	Gasket for W15.6" (1 pcs)
PFXAPPAF12P2	Installation fastener for PS5000
PFXZPSPUAC3	AC Power Supply unit for PS5000 Slim Panel PC Core

Ordering Information

PS - 5711W - i3 - * * - *

Form Factor	Simple and Enclosed Panel PC
Product Generation	Second Generation
Panel PC and Modular Displays	711W: 15" Widescreen (PS5711W)
Box PC	None (S-Panel or Enclosed Panel)
CPU	i3: Performance Core i3-4010U
Power Supply	D: 24 vDC
Memory	8G: 8 GB
Operating System	None
	WES7: WES7 Premium SP1 64bit En MUI
	W764: Win7 Ultimate FES SP1 64bit En MUI
	WE8: Win8.1 Industry 64bit En MUI
	WS732: WES Win7 32bit En MUI
	W10643: Windows 10 IoT Enterprise 64bit MUI (i3)
Main Storage Device	SHD: HDD 500GB
	CF16CFast: CFast 16GB
	HHD: HDD 1TB
	SSD8: SSD 128GB
	SSD24: SSD 240GB
Optional Interfaces	None
	NV: Interface - NVRAM
	485X2: Interface - 2 x RS422/485 Isolated
	485X4: Interface - 4 x RS422/485
	232X2: Interface - 2 x RS232 Isolated
	232X4: Interface - 4 x RS232
	IO: Interface - 16DI / 8DO
	CO: Interface - 2x CanOpen CanBu
	PF: Interface - Profibus DP Master with NVRAM
	ETH: Interface - 1xEth. Gigabit IEEE1588 for IPC
	CL: Interface - GPRS/GSM (cellular)
	AUP: Interface - Audio (PCIe)
	DVII: Interface - DVI-I
	DVID: Interface - DVI-D
	VGAX2: Interface - 2 x VGA
	USBX2: Interface - 2 x USB 3.0
	ECAT: Interface - EtherCAT
	8XALOG: Interface - Mini PCIe 8x Analog Input
Secondary Storage	None
	CF16: CFast 16GB
	SHD: HDD 500GB
	HHD: HDD 1TB
	SSD8: SSD 80GB
	SSD16: SSD 160GB
	SSD24: SSD 240GB
Software	None
	WGP: WinGP
	HMIS Remote HMI Server
	WGPHMIS: WinGP + Remote HMI Server
	OPN15: BLUE Open Studio Runtime 1.5K tags
	OPN32: BLUE Open Studio Runtime 32K tags
	OPN40: BLUE Open Studio Runtime 4K tags
	OPN64: BLUE Open Studio Runtime 64K tags
Extended Warranty	None (2 year standard)
	One year extended
	Two year extended

Pro-face America
 Phone: 734.477.0600
 Fax: 734.864.7347
 www.profaceamerica.com

Customer Service Hotline: 800.289.9266

For more information

ACCESS www.profaceamerica.com