

PS5800W Universal Modular Industrial PC

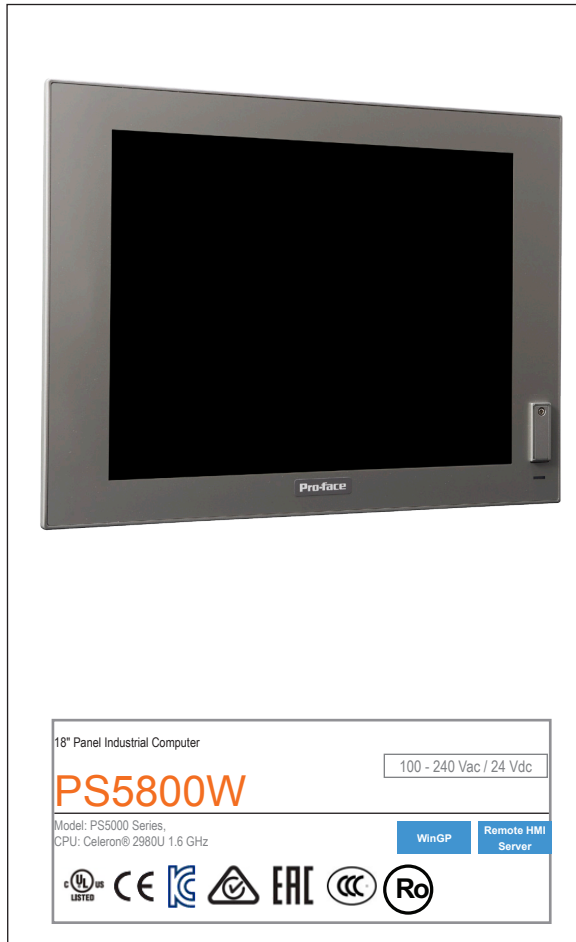

Features:

- Celeron® 2980U 1.6 GHz
- Fan-less Design
- Extensive Connectivity
- Modular Flexible Design
- TFT Color LCD Display
- VESA Mounting Options

Performance Specifications

Models	PS5000 Series (Build to Order)	
Graphics Display Resolution	FWXGA TFT (1,366 x 768 pixels)	
Display Type & Size	TFT Color LCD 18.5" (wide 16:9)	
Display Colors	16.7 Million	
Touch Panel	Capacitive multi-touch 5 simultaneous touch (projected capacitive)	
Panel Resolution	4096 x 4096	
Graphic Accelerator	Intel HD Graphics	
Supported OS	Windows® 7 Ultimate 64 bit MUI / Windows® Embedded Standard 7 (WES7P) 64 bit MUI / Windows® Embedded 8.1 Industry 64 bit MUI	
CPU	Celeron® 2980U 1.6 GHz	
Main Memory	4 GB / 8 GB, DDR3L 1600 MHz, SO-DIMM SDRAM 512 KB MRAM for the user	
Video Memory	Up to 1.7 GB, Shared system memory	
Interfaces	Serial ATA	HDD / SSD x 2 *1 CFast x 1 mSATA x 1
	Serial (COM1)	RS-232C / 422 / 485 (D-Sub 9-pin, plug)
	Ethernet (LAN1)	10/100/1000 Mbit/s (RJ-45 Modular jack)
	Ethernet (LAN2)	10/100/1000 Mbit/s (RJ-45 Modular jack)
	USB	USB 3.0 x 2, USB 2.0 x 2 (Type A)
	Video	DisplayPort (Type A) x 1
	Mini PCIe	x 2 (revision 1.2)
	Expansion Slot *2	PCIe (x4) x 2 / PCI x 2 / PCI x 1 + PCIe (x4) x 1

*1 When installed, an optional disk adapter unit (PFXZPBADHDD2) that is separately sold is required. *2 2 slot model only.

General Specifications

Models	PS5000 Series (Build to Order)
Input Voltage	DC Power Model: 24 Vdc ±20 % When using AC power supply unit: 100 to 240 Vac *3
Power Consumption	27.9 W (Max. 43.1 W)
In-Rush Current	8.9 A
Storage Temperature	-30 to 70° [-22 to 158°]
Certifications	CE (EN61000-6-4, EN61000-6-2, EN61131-2), CSA/UL60950, RCM (C-Tick), EAC (GOST-R), RoHS, REACH, CCC, KC, WEEE
Concussion Resistance	IEC60068-2-27 Ea Test
Pollution Degree	For use in pollution degree 2 environment
Cooling Method	Passive heat sink*4
Surrounding Air Temperature	When using SSD / CFast running: 0 to 55° [32 to 131°] When using HDD running: 0 to 45° [32 to 113°] When using mPCI x 2 + Display module : 0 to 45° [32 to 113°] When using PCI/PCIe : 0 to 45° [32 to 113°]
Ambient/Storage Humidity	10 to 95 % RH (Wet bulb temperature: 40 °C [104 °F] max. - no condensation)
Installation Configuration	Panel Mounting or VESA mounting with optional kit *5
Air Pressure (altitude range)	2,000 m (6,560 ft) max
Vibration Resistance	Operation for products with SSD or CF card storage device: 5 to 500 Hz: 2 Grms Operation for products with HDD storage device: 5 to 500 Hz: 1 Grms
Electromagnetic Compatibility	Immunity to High Frequency Interference. Electromagnetic Emissions Class A
Structure	IP66 (front side of display)
Weight	0 slot: 8.3 kg (18.3 lbs) 2 slot: 9.1 kg (20.1 lbs.)
External Dimensions	0 slot: W488.3 x H309.0 x D93.2 mm [W19.21 x H12.17 x D3.67 in.] 2 slot: W488.3 x H309.0 x D131.2 mm [W19.21 x H12.17 x D5.16 in.]
Panel Cut-Out Dimensions	W479.3 x H300.3 mm [W18.87 x H11.82 in.]
Warranty	Two (2) years

*3 For use at 100 to 240 Vac, an optional AC power adapter (PFXZBPBUAC2) that is separately sold is required. *4 VESA mounting kit sold separately is required, 0 slot: PFXZPBADVS02, 2 slot: PFXZPBADVS22 *5 The operating temperature is limited to 45 C and the cooling fan is required for PCI/PCIe cards installed on board with power consumption from 3W to 6W max. for two cards or 10W max for one card.

External Dimensions

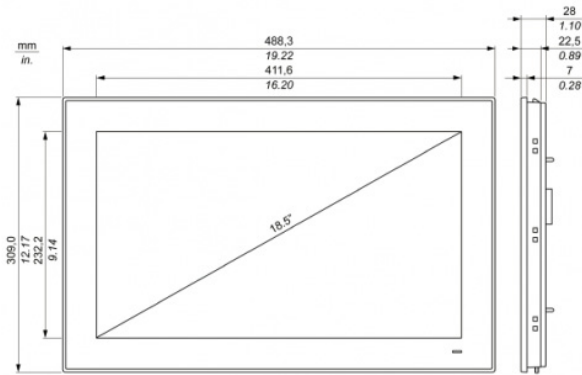

Panel Cut Dimensions

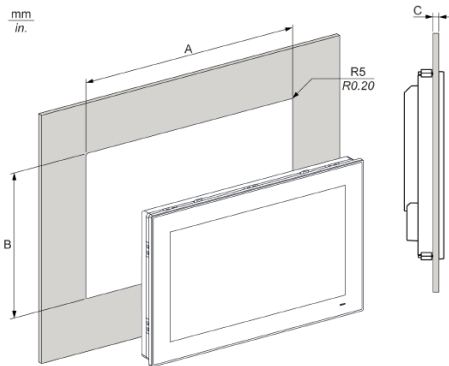

Industrial Personal Computer Cut-out	A	B	C	R
19" Wide	479.3 ±1 mm (18.87 ±0.04 in)	300.3 ±0.7 mm (11.82 ±0.03 in)	2 to 6 mm (0.08 to 0.23 in.)	5 mm (0.20 in.)

In addition to the wide variety of standard interfaces, additional interface options allow for extensive connectivity and product expansion.



See profaceamerica.com for optional accessories.

Ordering Information

PS - 5800W - CE - * * - *

- Panel PC and Modular Displays....** **800W:** Modular Display 19" Widescreen
- Box PC.....**
- CE-4G:** Box PC Celeron 4GB (1xDP, 2xEth., 1xCOM, 4xUSB, MRAM)
 - CE-8G:** Box PC Celeron 8GB (1xDP, 2xEth., 1xCOM, 4xUSB, MRAM)
 - CE-4G-1P1E:** Box PC Celeron 4GB 1 PCI + 1 PCIe (1xDP, 2xEth., 1xCOM, 4xUSB, MRAM)
 - CE-8G-1P1E-CC:** Box PC Celeron 8GB-RAM, 1 PCI+1 PCIe Conformal Coating (1xDP, 2xEth., 1xCOM, 4xUSB, MRAM)
 - CE-4G-2P:** Box PC Celeron 4GB-RAM, 2 PCI (1xDP, 2xEth., 1xCOM, 4xUSB, MRAM)
 - CE-8G-2P:** Box PC Celeron 8GB-RAM, 2 PCI (1xDP, 2xEth., 1xCOM, 4xUSB, MRAM)
 - CE-4G-2E:** Box PC Celeron 4GB-RAM, 2 PCIe (1xDP, 2xEth., 1xCOM, 4xUSB, MRAM)
 - CE-8G-2E:** Box PC Celeron 8GB-RAM, 2 PCIe (1xDP, 2xEth., 1xCOM, 4xUSB, MRAM)
- CPU Fan Kit** None
F: CPU Fan Kit for expansion cards above 3W
- Power Supply.....** **D:** 24 vDC
A: 100 - 240 AC
- Operating System.....** None
WEST7: Windows Embedded Standard 7 (WES7P) SP1 64 bits MUI
W764: Win7 Ultimate FES SP1 64bit En MUI
WE8 : Win8.1 Industry 64bit En MUI
- Main Storage Device** None
CF16: CFast 16GB
SHD: HDD 500GB
HHD: HDD 1TB
SSD8: SSD 80GB
SSD16: SSD 160GB
SSD24: SSD 240GB
- Optional Interfaces** None
485X2: Interface - RS485 x 2 Isolated
485X4: Interface - 4 x RS422/485
USBX2: Interface - 2 x USB 3.0
232X2: Interface - 2 x RS232 Isolated
232X4: Interface - 4 x RS232
IO: Interface - 16DI / 8DO
AU: Interface - Audio
CL: Interface - 1x GPRS/GSM
ETH: Interface - Gigabit IEEE 1588 Lan
CO: Interface - 2x CanOpen CanBus
PF: Interface - Profibus DP Master with NVRAM
LANX2: Interface - 2x PoE LAN
- Secondary Storage** None
CF16: CFast 16GB
SHD: HDD 500GB
HHD: HDD 1TB
SSD8: SSD 80GB
SSD16: SSD 160GB
SSD24: SSD 240GB
- Software** None
WGP: WinGP
HMIS: Remote HMI Server
WGPHMIS: WinGP + Remote HMI Server
OPN15: BLUE Open Studio Runtime 1.5K tags
OPN40: BLUE Open Studio Runtime 4K tags
OPN64: BLUE Open Studio Runtime 64K tags
- Extended Warranty** None (2 year standard)
 One year extended
 Two year extended

Pro-face America

Phone: 734.477.0600

Fax: 734.864.7347

www.profaceamerica.com

Customer Service Hotline: 800.289.9266

For more information

ACCESS

www.profaceamerica.com



California Proposition 65 Warning—Lead and Lead Compounds

Advertencia de la Proposición 65 de California—Plomo y compuestos de plomo

Avertissement concernant la Proposition 65 de Californie—Plomb et composés de plomb

⚠ WARNING: This product can expose you to chemicals including lead and lead compounds, which are known to the State of California to cause cancer and birth defects or other reproductive harm. For more information go to: www.P65Warnings.ca.gov.

⚠ ADVERTENCIA: Este producto puede exponerle a químicos incluyendo plomo y compuestos de plomo, que es (son) conocido(s) por el Estado de California como causante(s) de cáncer y defectos de nacimiento u otros daños reproductivos. Para mayor información, visite : www.P65Warnings.ca.gov.

⚠ AVERTISSEMENT: Ce produit peut vous exposer à des agents chimiques, y compris plomb et composés de plomb, identifiés par l'État de Californie comme pouvant causer le cancer et des malformations congénitales ou autres troubles de l'appareil reproducteur. Pour de plus amples informations, prière de consulter: www.P65Warnings.ca.gov.

All trademarks are the property of Schneider Electric SE, its subsidiaries, and affiliated companies.

Schneider Electric USA, Inc.
800 Federal Street
Andover, MA 01810 USA
888-778-2733
www.schneider-electric.us

Todas las marcas comerciales son propiedad de Schneider Electric SE, sus filiales y compañías afiliadas.

Importado en México por:
Schneider Electric México, S.A. de C.V.
Av. Ejercito Nacional No. 904
Col. Palmas, Polanco 11560 México, D.F.
55-5804-5000
www.schneider-electric.com.mx

Toutes les marques commerciales sont la propriété de Schneider Electric SE, ses filiales et compagnies affiliées.

Schneider Electric Canada, Inc.
5985 McLaughlin Road
Mississauga, ON L5R 1B8 Canada
800-565-6699
www.schneider-electric.ca