

# 9.1" PanelStation HMI - QPI-3x200-E2P



**Features:**

- High Intensity Electroluminescent Display
- System alarm output
- Serial communication interface
- Optional Communication Module Interface

Performance Specifications		
Model	QPI-3x200-E2P	
Display	Type	9.1" High Intensity EL
	Colors	Amber / Black Monochrome
	Resolution	640 X 400 pixels
	Brightness Adjustment	2 levels of adjustment available via touch panel
	Effective Display Area (mm)	192mm(W)×120mm(H)
	Language Fonts	ASCII: (Code Page 850)Alphanumeric (incl. European fonts) *1 Chinese: (GB2312-80 codes) simplified Chinese fonts Japanese: ANK 158 type, Kanji: 6962 (Standard JIS Type 1 & 2) Korean: (KSC5601-1992 codes) Hangul font Taiwanese: (Big 5 codes) traditional Chinese fonts
No. of Char. Display	8×8 dot font	80 characters per row, 50 rows
	8×16 dot font	80 characters per row, 25 rows
	16×16 dot font	40 characters per row, 25 rows
Font Size	Character Size: Height and width can be expanded 1, 2, 4, or 8	
Application Memory	2MB FLASH EPROM	
Touch Panel (Resistive Film)	32×20Keys/ screen; 1 or 2 point touch	
Interfaces	Serial	Asynchronous transmission method: RS-232C/ RS-422; Data length: 8/7 bits: 2/1 bits; stop bits: 2/1 bits; Parity: None/ Even/ Odd; Data Transmission Rate: 2400bps to 115.2 kbps
	Tool Connector	Asynchronous Transmission Method, TTL level, non-procedural command interface [during screen development] used for transferring application screen data [during RUN mode] used as Bar-code Reader or built-in 2-port function interface
	Auxiliary Input / Output(AUX)	Touch switch output: DC24V×8 points; (inching): DC24V×1 point; System alarm output: DC24V×1 point; Buzzer output: DC24V×1 point; RUN output
	Printer Interface	Conforms to Centronix (HP LaserJet PCL4 compatible, NEC PR Series, EPSON ESC/P or equivalent)

General Specifications			
Model	QPI-31200-E2P	QPI-3D200-E2P	
Electrical	Input Voltage	110V AC	24V DC
	Rated Voltage	AC85V to AC132V 50/60Hz	DC 20.4V to DC 27.6V
	Power Consumption	50VA or less	50W or less (TYP 20W)
	Allowable Voltage Drop	1 cycle or less	Up to 2 ms
	Voltage Endurance	AC 1500V-20mA 1 minute	AC 1000V-10mA 1 minute (between charging and FG terminals)
Environmental	Insulation Resistance	Above 10Mohm at DC500V (between charging and FG terminals)	
	Ambient Operating Temp.	0°C (32°F) to 50°C (122°F)	
	Storage Temperature	-10°C (14°F) to 60°C (140°F)	
	Humidity	20 to 85%RH (non-condensing)	
	Vibration Resistance	10 to 25 Hz (X, Y, Z directions 30 minutes each 19.6m/s2)	
	Noise Immunity (via noise simulator)	Noise voltage: 1200Vp-p; Pulse length: 1μs; Arise Time: 1ns	Noise voltage: 1000Vp-p; Pulse length: 1μs; Arise Time: 1ns
Structural	Corrosive Gasses	Free of corrosive gasses	
	Grounding	100ohm or less, or your country's applicable standard *1	
	Ratings	Equivalent to IP65f *2, Nema #250 Type 4/4x12 (Limited to front face of GP installed in panel)	
	Certifications	UL/c-UL Listed, CSA (UL508, UL1604 Class 1, Div 2, CSA-C22.2 No.142), CE EN55011 Class A, EN61000-6-2	-
	External Dimensions	274mm(W)×216mm(H)×56.5mm(D) (GP unit only)	
	Panel Cut-out Dimensions	259(+1 / -0)mm [10.20(+0.04 / -0)in.] x 201(+1 / -0)mm [7.91(+0.04 / -0)in.] (Panel thickness: 1.6mm [0.06in.] to 10mm [0.40in.])	
	Weight	Less than 2.5kg (GP unit only)	
Warranty	Two year standard		

\*1 Grounding requirements differ from country to country. Be sure to confirm your work environment requirements prior to installation. For more information, please contact your local Pro-face distributor.

\*2 The degree of protection provided by these products is equivalent to IP65f, however their performance cannot be guaranteed for every environment. Be sure to confirm your work environment requirements prior to installation.

**Dimensions**

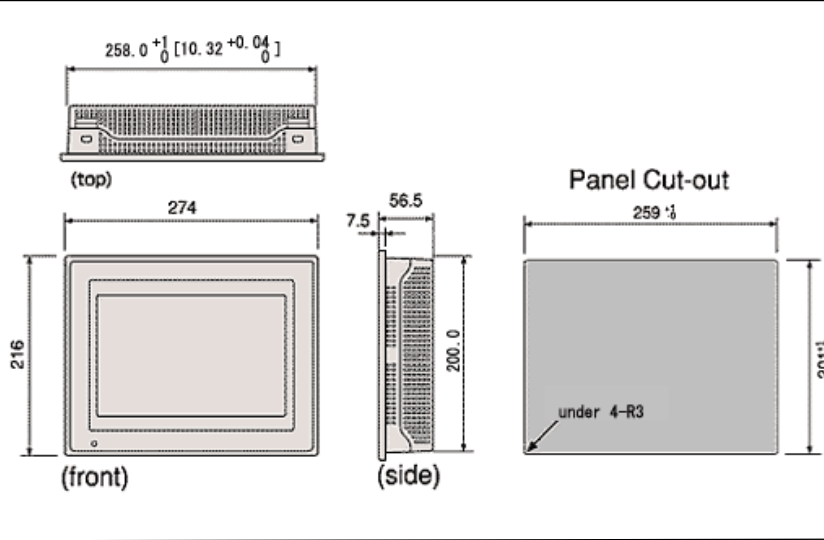

**Ordering Information**

Part Number	Description
QPI-31200-E2P	9.1" High Intensity Electroluminescent, Serial, 110VAC
QPI-3D200-E2P	9.1" High Intensity Electroluminescent, Serial, 24VDC

**Optional Items**

Part Number	Product Name
QPI-ABD-201	AB Data Highway Plus Communication Module
QPI-ABR-201	AB 1771 Remote I/O Communication Module
QPI-PBS-201	Profibus DP Slave Communication Module
QPI-DVN-202	DeviceNet Slave Communication Module
QPI-MBP-XA1	Modbus Plus Communication Module (no adapter required)
GP077-MLTE41	GP477R Multi Unit E with Ethernet, Sound, and CompactFlash.
HMI-CAB-C52	Communication cable - PanelStation to SLC RS-232C 9-pin D-sub port
HMI-CAB-C83	Communication cable - PanelStation to SLC DH485 Program Port via 8 pin RJ45 modular phone connector
HMI-CAB-C84	Communication cable - PanelStation to SLC DH485 Program Port via 8 pin RJ45 modular phone connector plus includes 8 pin socket modular phone connector, 6 ft.
HMI-CAB-C106	Communication cable - PanelStation to Micrologix RS-232C 8-pin circular DIN port
HMI-CAB-C53	Communication cable - PanelStation to Modicon 984 RS-232C port via 25 pin D-Sub
HMI-CAB-C105	Printer cable, PanelStation tool port to 9pin female connector, RS-232C, 10 Ft.
GP470/477-DF10	Touch Screen Hard Protection Sheet (Qty 5) for QPI-xxxxx-E2P units
QDA-EDT-001	QuickDesigner 3.7 Software w/ GPW-CB02 RS-232C programming cable (Not supported on Windows XP or Vista Operating Systems)
QDA-EDT-001/L	QuickDesigner 3.7 Software - no programming cable (Not supported on Windows XP or Vista Operating Systems)
GPW-CB02	RS-232C Programming Cable
GP070-AT01	Mounting Fasteners

**Caution:** Before operating any of these products, please be sure to read all related manuals thoroughly.

- All product names used in this document are trademarks or registered trademarks of their respective companies.
- All information contained in this document is subject to change without notice.

For cutout compatible units refer to Pro-face's PanelStation Migration Guide:  
<http://www.profaceamerica.com/cms/site/cc4edaf95cbe432/index.html>

**Accessories**



**Software**



Powered by  
**QUICKDESIGNER™**  
HMI Development Software  
(Version 3.7)

**Pro-face America**  
Phone: 734.429.4971  
Fax: 734.429.1010  
[www.profaceamerica.com](http://www.profaceamerica.com)

**Customer Service Hotline: 734.944.0482**

For more information  
**ACCESS** [www.profaceamerica.com](http://www.profaceamerica.com)



# California Proposition 65 Warning—Lead and Lead Compounds

## Advertencia de la Proposición 65 de California—Plomo y compuestos de plomo

### Avertissement concernant la Proposition 65 de Californie—Plomb et composés de plomb

**⚠️ WARNING:** This product can expose you to chemicals including lead and lead compounds, which are known to the State of California to cause cancer and birth defects or other reproductive harm. For more information go to: [www.P65Warnings.ca.gov](http://www.P65Warnings.ca.gov).

**⚠️ ADVERTENCIA:** Este producto puede exponerle a químicos incluyendo plomo y compuestos de plomo, que es (son) conocido(s) por el Estado de California como causante(s) de cáncer y defectos de nacimiento u otros daños reproductivos. Para mayor información, visite : [www.P65Warnings.ca.gov](http://www.P65Warnings.ca.gov).

**⚠️ AVERTISSEMENT:** Ce produit peut vous exposer à des agents chimiques, y compris plomb et composés de plomb, identifiés par l'État de Californie comme pouvant causer le cancer et des malformations congénitales ou autres troubles de l'appareil reproducteur. Pour de plus amples informations, prière de consulter: [www.P65Warnings.ca.gov](http://www.P65Warnings.ca.gov).

All trademarks are the property of Schneider Electric SE, its subsidiaries, and affiliated companies.

**Schneider Electric USA, Inc.**  
800 Federal Street  
Andover, MA 01810 USA  
888-778-2733  
[www.schneider-electric.us](http://www.schneider-electric.us)

Todas las marcas comerciales son propiedad de Schneider Electric SE, sus filiales y compañías afiliadas.

Importado en México por:  
**Schneider Electric México, S.A. de C.V.**  
Av. Ejercito Nacional No. 904  
Col. Palmas, Polanco 11560 México, D.F.  
55-5804-5000  
[www.schneider-electric.com.mx](http://www.schneider-electric.com.mx)

Toutes les marques commerciales sont la propriété de Schneider Electric SE, ses filiales et compagnies affiliées.

**Schneider Electric Canada, Inc.**  
5985 McLaughlin Road  
Mississauga, ON L5R 1B8 Canada  
800-565-6699  
[www.schneider-electric.ca](http://www.schneider-electric.ca)