

Pro-face AGP/AST3000 to Yaskawa J7 Drive via Modbus RTU

Tested, Trusted, Out-of-the-Box

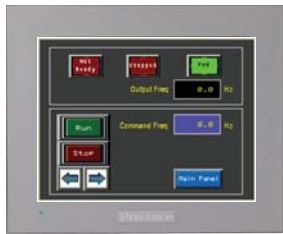

Pro-face AGP3300-T1

Modbus
Serial Cable



Yaskawa
J7 Drive

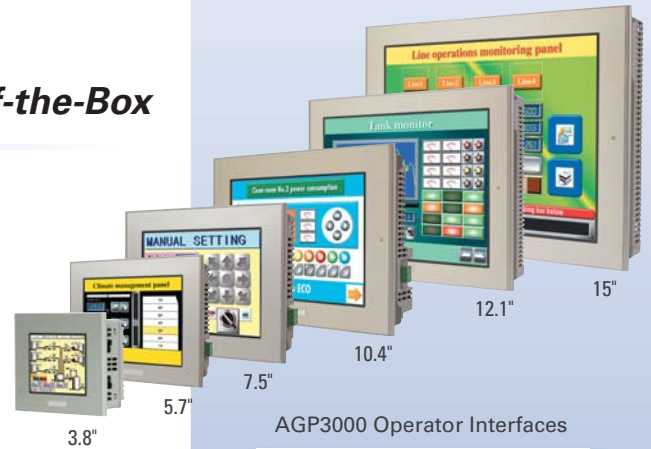

AGP3000 Operator Interfaces



HMI Motion Quick Start Guides

Pro-face HMI motion control quick start guides make it easy to integrate variable speed drives directly to your operator interface and control system. With minimal knowledge a user can quickly set up a variable speed drive operator interface without requiring a separate programmable controller and drive interface wiring.

Differentiating Value:

- Simple, fast installation, 3 step guide with a sample project you can use
- No PLC required, logic controller is built-in
- Reduce system cost, no need for analog interfaces, eliminate pilot lights and push buttons
- Precision high resolution digital control

Applications:

- Conveyors
- Pumps and fans
- Packaging equipment
- Discrete manufacturing

These instructions along with the downloadable sample project facilitate quickly connecting and establishing communications between a Pro-face AGP using GP-Pro EX and a Yaskawa J7 Drive. For a full explanation of this project refer to Pro-face America Application Note 1157.

Materials:

1. Pro-face GP-Pro EX Screen and Logic Editing software v2.1 or higher
2. Pro-face AGP3000 or AST3000 Series HMI
3. Yaskawa J7 Drive
4. Yaskawa SI-485/J7 Modbus RS485 Adapter
5. Pro-face CA4-ADP0NL-01 COM2 Port Adapter
6. Pro-face CA3-ADPTRM-01 Termination Adapter
7. 5-Wire Shielded Cable
8. The Pro-face sample project "APNT1157.zip"
available at: <https://www.hmisource.com/otasuke/files/apnotes/>

Continued on next page



Quick Start Guide: Pro-face AGP/AST3000 to Yaskawa J7 Drive via Modbus RTU



Easy Configuration

STEP 1 - Connecting to the Drive

The Yaskawa J7 Drive communicates using Modbus RTU via the S+|S-|R+|R- connections on the optional Yaskawa SI-485/J7 adapter attached to the front of the Yaskawa J7 Drive.

- Once the adapter is installed, enable termination, as shown in the instruction manual, for 1:1 connection between the AGP and the Yaskawa Drive since the drive will be the last device on the Modbus network.
- To make this cable connection quickly, use the following Pro-face cable adapters:
 - CA3-ADPTRM-01 Breakout Adapter
 - CA3-ADPCOM-01 Port Adapter for COM1 (*AGP3302B COM2) or CA4-ADPONL-01 Port Adapter for COM2 (*Not for use with AGP3202B)
- In the sample project, COM2 is connected on the AGP3300T to the Yaskawa J7 Drive via RS422\485 4 wire communication. For this reason, the following cable diagram (fig 2a) indicates to use the CA4-ADPONL-01 adapter. If COM1 will be used in your project, simply substitute the CA3-ADPCOM-01 for the CA4-ADPONL-01 adapter. **These port adapters are not simply gender changers.**

STEP 1 - Cable Adapters:



CA3-ADPTRM-01



CA3-ADPCOM-01



CA4-ADPONL-01

2a - Cable Diagram

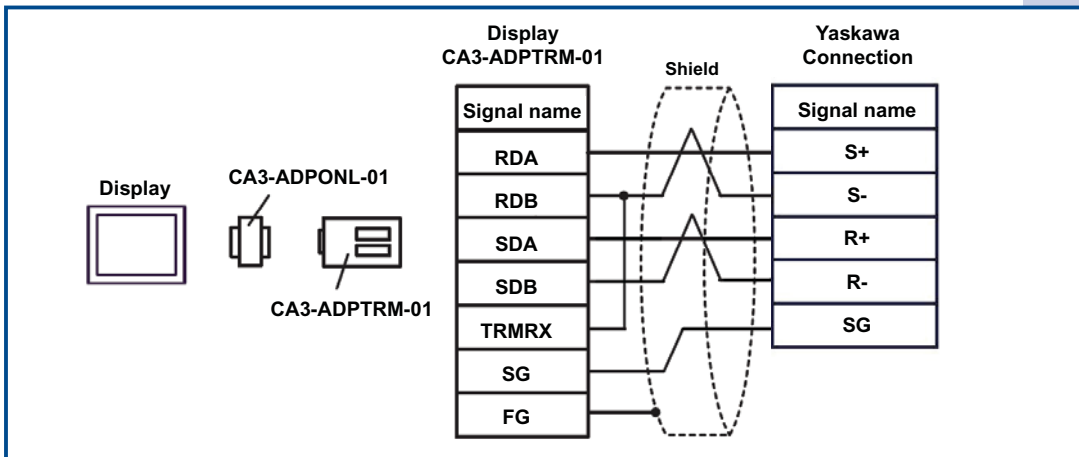

2b - Cable Diagram to build the cable without using the Pro-face adapters

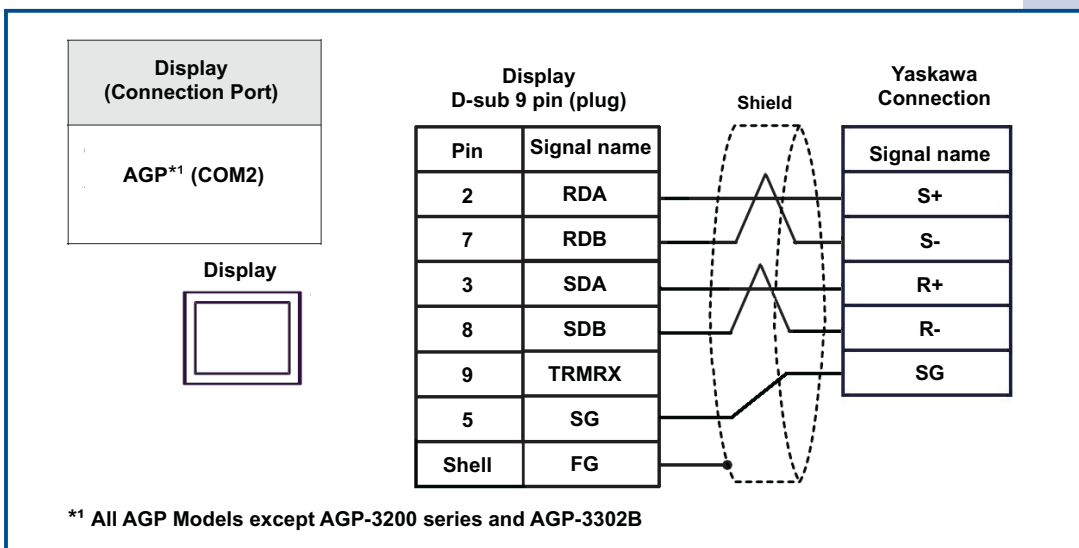

Continued on next page

Quick Start Guide: Pro-face AGP/AST3000 to Yaskawa J7 Drive via Modbus RTU

STEP 2 - Configure the Drive

- Set up the following drive parameters as shown section 5-14 of the Yaskawa J7 Manual for use with the enclosed sample project.
 - n02 – Operation Method Selection – 02 [Run\Stop Command via Serial]
 - n03 – Reference Selection – 06 [Frequency Reference via Modbus]
 - n36-39 – Serial vs. External Terminal Input (*default settings, see manual for details*)
 - n69 – Frequency Resolution (*default, see manual for details*)
 - n70 – Modbus Slave Address – 01
 - n71 – Baud Rate – 03 [19,200]
 - n72 – Parity – 02 [None]
 - n68 – Modbus Timeout Detection – 04 [*Disabled*]
- Power cycle the Yaskawa Drive to ensure the new settings take effect.

STEP 3 - Configure the Operator Interface

The sample project is already configured for an AGP3300. Simply download the project to the operator interface. When the download is complete press “Operator Panel” to view drive status and operate the drive.

Using a Different Model AGP/AST/LT3xxx:

The following models of the Pro-face 3000 series can be used with this sample project:

Panel Size	Series	Class/Type			
		Standard	Control	Multimedia	Hand-held
All	AGP3xxx	✓	✓	✓	✓
All	AST3xxx	✓	✗	✗	✗
All	LT33xx	✗	✓ ^{*1}	✗	✗

The sample project is configured for an AGP3300T. To use the project with a different model AGP and screen size, follow these steps:

- Open the enclosed GP-Pro EX project, click “Project (F)” then “System Settings (C)”.
- Click on “Display” in the System Settings menu then “Change Display Unit”.
- Select the series line and model of the your AGP. If the “Convert Resolution” prompt appears, check the box to automatically resize all screen objects in the application.
- Click “OK” to the reminder to check the screen objects before downloading to an AGP.
- Click “YES” to acknowledge that AGP models have hardware capabilities.
- Save the project to a new file.

*Note: ^{*1}To use the sample project with a LT33xx: Open the project in GP-Pro EX. Open another instance of GP-Pro EX and select the LT33xx model you are using. Copy the desired screens from the first instance to the second.*

Download the Project:

The sample project includes a screen “Operator Panel” (B20). It includes common operator interface controls on a single screen for your convenience. All other screens in this project can be deleted.

Project Screen:

