

## Pro-face AGP/AST3000 to Trio Motion Controller via Modbus RTU

*Tested, Trusted, Out-of-the-Box*



Pro-face AGP3300-T1

Modbus  
Serial Cable



Trio  
MC302X Motion Control

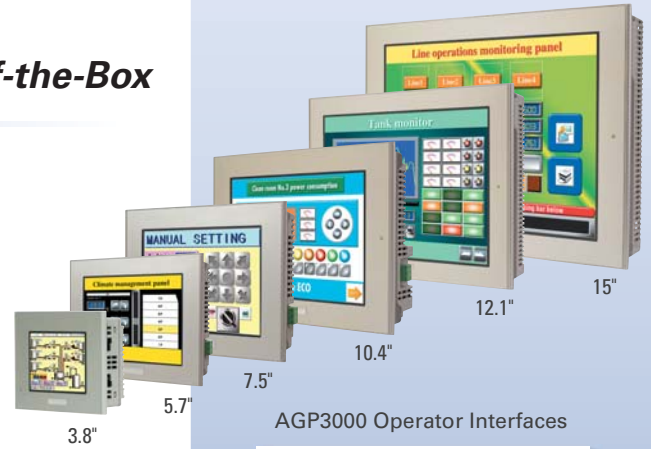

AGP3000 Operator Interfaces

# Pro-face®

### HMI Motion Control Quick Start Guides

Pro-face HMI motion control quick start guides make it easy to integrate the Trio Motion Coordinator directly to your operator interface and control system. With minimal knowledge, a user can quickly set up a motion controller operator interface without requiring a separate programmable controller and controller interface wiring.

#### Differentiating Value:

- Simple, fast installation, 3 step guide with a sample project you can use
- No PLC required, logic controller is built-in
- Reduce system cost, no need for analog interfaces, eliminate pilot lights and push buttons
- Precision high resolution digital control

#### Applications:

- Machining
- Robotics
- Flying Shears
- Winders
- High Speed Labelers
- Packaging

These instructions along with the downloadable sample project facilitate quickly connecting and establishing communications between a Pro-face AGP using GP-Pro EX and a Trio MC302X Motion Coordinator. For a full explanation of this project refer to Pro-face America Application Note 1171.

#### Materials:

1. Pro-face GP-Pro EX Screen and Logic Editing software v2.1 or higher
2. Pro-face AGP3000 or AST3000 Series HMI
3. Trio MC302X Motion Controller
4. Trio P354 Mini-DIN to Flying lead 3m cable
5. Trio Motion Perfect 2 software and cable
6. Pro-face CA3-ADPCOM-01 Port Adapter or CA4-ADPONL-01 COM2 Port Adapter
7. Pro-face CA3-ADPTRM-01 Termination Adapter
8. The Pro-face sample project "APNT1171.zip" available at: <https://www.hmisoftware.com/otasuke/files/appnotes/>

*Continued on next page*



# TRIO

MOTION TECHNOLOGY



# Quick Start Guide: Pro-face AGP/AST3000 to Trio Motion Controller via Modbus RTU



## Easy Configuration

### STEP 1 - Connecting to the Motion Controller

The Trio MC302X Motion Controller communicates using the Modbus RTU protocol via a Mini-DIN serial interface.

- To make this cable connection quickly, use the following Pro-face cable adapters:
  - CA3-ADPTRM-01 Breakout Adapter
  - CA3-ADPCOM-01 Port Adapter for COM1 (\*AGP3302B COM2) or CA4-ADPONL-01 port adapter for COM2 (\*Not for use with AGP3202B)
- In the sample project, COM1 on the AGP3300T is connected to the Trio MC302X Motion Controller Serial Connector B via RS422\485 2 wire communication. For this reason, the following cable diagram (fig 2a) indicates to use the CA3-ADPCOM-01 adapter. If COM2 will be used in your project, simply substitute the CA4-ADPONL-01 adapter for the CA3-ADPCOM-01 adapter. **These port adapters are not simply gender changers.**

To simplify building the cable the Trio P354 cable conductors are color coded as indicated in the diagrams below.

2a - Cable Diagram

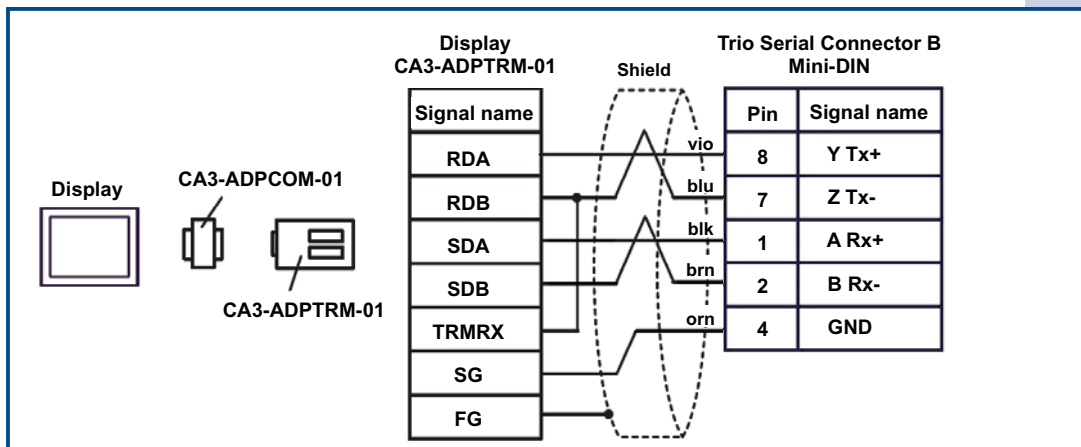

### STEP 1 - Cable Adapters:



CA3-ADPTRM-01



CA3-ADPCOM-01



CA4-ADPONL-01

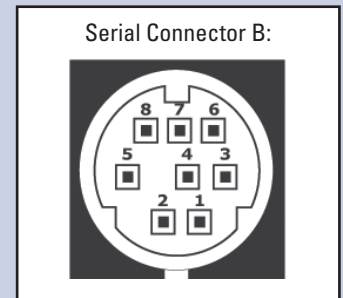

2b - Cable diagram to build the cable without using the Pro-face adapters

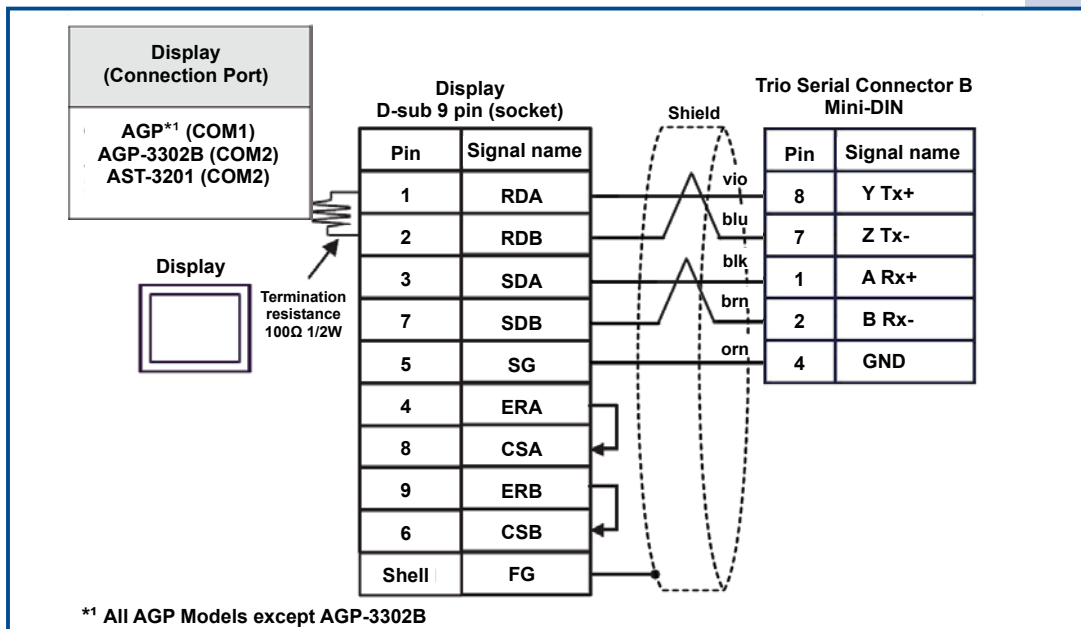

\*1 All AGP Models except AGP-3302B

# Quick Start Guide: Pro-face AGP/AST3000 to Trio Motion Controller via Modbus RTU



## STEP 2 - Configure the Motion Controller

The only wiring required to operate this sample project is the 24VDC power connection and the above communication cabling. Configure the Motion Trio controller by simply downloading the Motion Perfect project to it.

## STEP 3 - Configure the Operator Interface

The sample project is already configured for an AGP3300. Simply download the project to the operator interface. When the download is complete press "Operator Panel" to view drive status and operate the drive.

## Using a Different Model AGP/AST/LT33xx:

The following models of the Pro-face 3000 series can be used with the sample project:

Panel Size	Series	Class/Type			
		Standard	Control	Multimedia	Hand-held
All	AGP3xxx	✓	✓	✓	✓
All	AST3xxx	✓	✗	✗	✗
All	LT33xx	✗	✓*1	✗	✗

The sample project is configured for an AGP3300T. To use the project with a different model (AGP) and screen size, follow these steps:

1. Open the enclosed GP-Pro EX project, click "Project (F)" then "System Settings (C)".
2. Click on "Display" in the System Settings menu then "Change Display Unit".
3. Select the series line and model of your AGP. If the "Convert Resolution" prompt appears, check the box to automatically resize all screen objects in the application.
4. Click "OK" to the reminder to check the screen objects before downloading to an AGP.
5. Click "YES" to acknowledge that AGP models have hardware capabilities.
6. Save the project to a new file.

Note: \*1 To use the sample project with a LT33xx: Open the project in GP-Pro EX. Open another instance of GP-Pro EX and select the LT33xx model you are using. Copy the desired screens from the first instance to the second.

## Customizing the Project:

The sample project includes a screen "Operator Panel" (B3). It includes common operator interface controls on a single screen for your convenience. All other screens in this project can be deleted.

Project Screen:

