

# SP-5600TA Advanced Display

## SP5000 SERIES

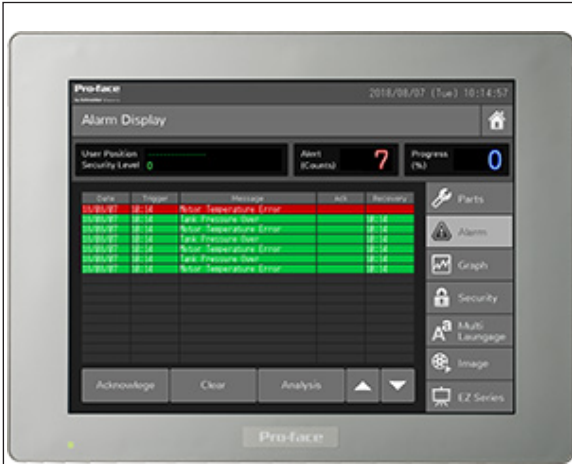

**Features:**

- XGA Display TFT Touch Panel
- 262,144 colors
- 12-24 Vdc input voltage
- 0-60C operating temperature

- Compatible with Open Box, Power Box, and Standard Box
- Embedded mounting clips for easy installation

**Performance Specifications**

Model	SP-5600TA	
Part Number	PFXSP5600TAD	PFXSP5600TADFOC
Conformal Coating	No	Yes
Graphics Display Resolution	1,024 x 768 pixels (XGA)	
Display Type and Size	TFT Color LCD 12.1"	
Display Colors	262,144 colors	
Effective Display Area	W245.8 x H184.3 mm (W9.68 x H7.26 in.)	
Touch Screen	Single touch, resistive film (analog)	
Backlight	White LED (Not user replaceable. When replacement is required, contact your local distributor.)	
Backlight Service Life	50,000 hours or more (continuous operation at 25 °C [77 °F] before backlight brightness decreases to 50%)	
Brightness Control	0...100 (Adjusted with touch panel or software)	

**General Specifications**

Models	SP-5600TA
Part Number	PFXSP5600TAD
Input Voltage	12-24 Vdc (limits 10.8 -29.9 Vdc)
Voltage Drop	12 Vdc: 1.25 ms or less/ 24 Vdc: 5 ms or less
In-Rush Current	30 A or less
Voltage Endurance	1,000 Vac, 20 mA for 1 minute (between charging and FG terminals)
Insulation Resistance	500 Vdc, 10 MQ or more (between charging and FG terminals)
Power Consumption*1	10 W (max), 2.5W or less (When screen turns off the backlight (Standby Mode), 5.7W or less (when screen backlight 20%)
Surrounding Air Temperature	0...60 °C [32...140 °F]
Storage Temperature	-20...60 °C [-4...140 °F]
Certifications	UL61010-2-201, UL/c-UL, CSA C22.2 No142, CE, RoHS, GOST-R, KC, ATEX Zone 2/22, IECEx Zone 2/22
Ratings*2	IP66F, IP67F, TYPE 4X (Indoor Use Only)/13 (on the front panel when properly installed in an enclosure), ANSI/ISA 12.12.0 1, UL508, EN61000-6-4, EN61000-6-2, Class 1 Div 2 Groups A, B, C, and D
Surrounding Air and Storage Humidity	10%...90% RH (Non condensing, wet bulb temperature 39 °C [102.2 °F] or less)
Dust	0.1 mg/m3 (10-7 oz/ft3) or less (non-conductive levels)
Pollution Degree	For use in Pollution Degree 2 environment
Corrosive Gas	Free of corrosive gases
Atmospheric Pressure (Operating Altitude)	800...1,114 hPa (2,000 m [6,561 ft] or lower)
Vibration and Shock Resistance	IEC/EN 61131-2 compliant
Electrostatic Discharge Immunity	Contact Discharge Method: 6 kV (IEC/EN 61000-4-2 Level 3)
Weight*8	3.2 kg (7.1 lb) or less
External Dimensions*3	W315 x H241 x D67 mm (W12.4 x H9.49 x D2.64 in.)
Panel Cut Dimensions	W301.5 x H227.5 mm (W11.87 x H8.96 in.)
Warranty	Two (2) years

\*1 Power Consumption for Display Module only. \*2 The front face of this product, installed in a solid panel, has been tested using conditions equivalent to the standard shown in the specification. \*3 When combined with Box Module, the depth is 67mm (2.64 in.). \*4 For dimensional tolerance, everything +1.0 mm (+0.04/0 in.) and R in angle are below R3 (R0.12 in.) \*4 Weight for Display Module only

**External Dimensions**

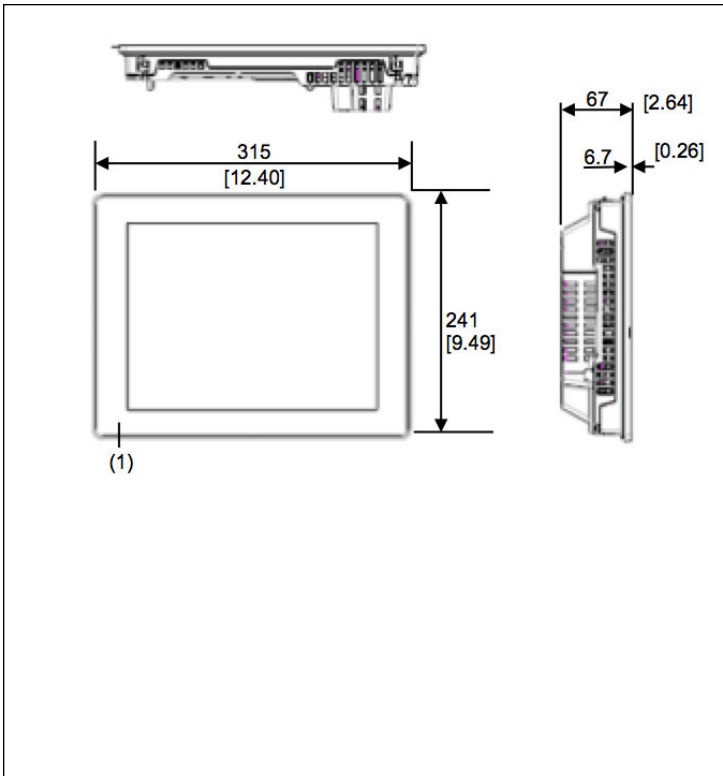

**Panel-Cut Out Dimensions**

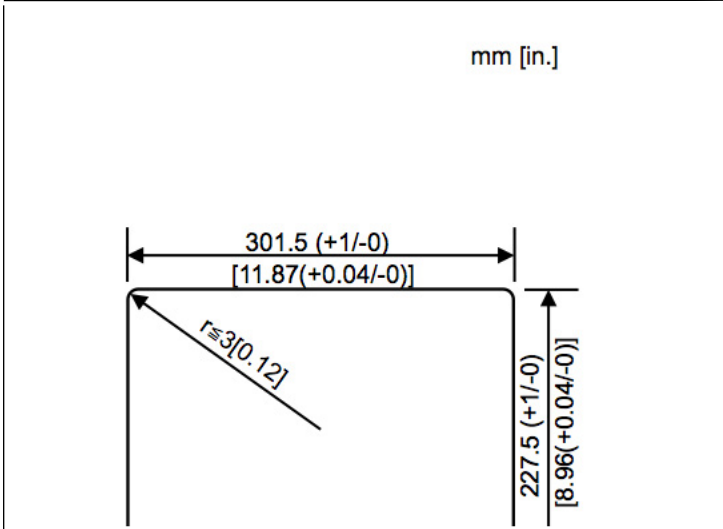

\*11 Even if the installation wall thickness is within the recommended range for the "Panel Cut Dimensions", depending on wall's material, size, and installation location of this product and other devices, the installation wall could warp. To prevent warping, the installation surface may need to be strengthened.

**Ordering Information**

Type	Model Numbers	Description
SP-5600TA	PFXSP5600TAD	12-inch TFT, 262,144 colors, XGA 1,024 x 768 pixels, Analog Touch Panel.
SP-5600TA	PFXSP5600TADF0C	SP5000 Series Advanced Display, 12.1" TFT, 262k colors, XGA 1024x768 pixels, Analog Touch Panel 12-24VDC, conformal coated

**Modular Design and Easy Maintenance**

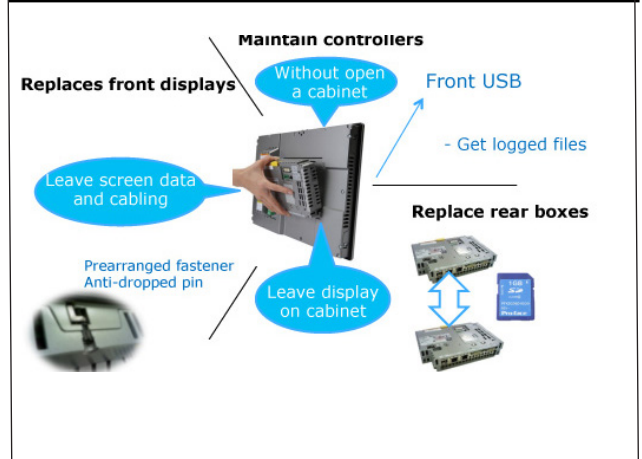

**Customer Service Hotline: 800.289.9266**

**Pro-face America**  
 Phone: 734.477.0600  
 www.profaceamerica.com

For more information  
**ACCESS** www.profaceamerica.com

