

SP-5600WA Advanced Display

SP5000 SERIES



Features:

- WVGA Display TFT Touch Panel
- 262,144 colors
- 12-24 Vdc input voltage
- 0-60C operating temperature
- Compatible with power or open box modules
- Embedded mounting clips for easy installation
- WVGA provides higher resolution than SVGA

Performance Specifications

Model	SP-5600WA	
Part Number	PFXSP5600WAD	PFXSP5600WADF0C
Graphics Display Resolution	1,280 x 800 pixels (WVGA)	
Display Type and Size	TFT Color LCD 12"	
Display Colors	262,144 colors	
Effective Display Area	W261.1 x H163.2mm (W10.28 x H6.43 in.)	
Touch Screen	Resistive film (analog)	
Backlight	White LED (Not user replaceable. When replacement is required, contact your local distributor.)	
Backlight Service Life	50,000 hours or more (continuous operation at 25 °C [77 °F] before backlight brightness decreases to 50%)	
Brightness	Max.:400cd(Typ)Min.:4cd(Typ) 0...100 (Adjusted with touch panel or software) ^{*1}	
<small>*1 The maximum and minimum brightness Value is the reference Value, because there are individual differences by the liquid crystal.</small>		

General Specifications

Models	SP-5600WA	
Part Number	PFXSP5600WAD	PFXSP5600WADF0C
Conformal Coating	-	Yes
Input Voltage	12-24 Vdc (limits 10.8 -29.9 Vdc)	
Voltage Drop	12 Vdc: 1.25 ms or less/ 24 Vdc: 5 ms or less	
In-Rush Current	30 A or less	
Voltage Endurance	1,000 Vac, 20 mA for 1 minute (between charging and FG terminals)	
Insulation Resistance	500 Vdc, 10 MQ or more (between charging and FG terminals)	
Power Consumption ^{*1}	11.5W (max), 2.5 or less (When screen turns off the backlight (Standby Mode), 6W or less (when screen backlight 20%)	
Surrounding Air Temperature	0...60 °C [32...140 °F]	
Storage Temperature	-20...60 °C [-4...140 °F]	
Certifications	CE, RoHS, GOST-R, UL/c-UL, KC	
Ratings ^{*2}	IP66F, IP67F, TYPE 4X (Indoor Use Only)/13 (on the front panel when properly installed in an enclosure), ANSI/ISA 12.12.0 1, UL508, EN61000-6-4, EN61000-6-2, Class 1 Div 2 Groups A, B, C, and D	
Surrounding Air and Storage Humidity	10%...90% RH (Non condensing, wet bulb temperature 39 °C [102.2 °F] or less)	
Dust	0.1 mg/m3 (10-7 oz/ft3) or less (non-conductive levels)	
Pollution Degree	For use in Pollution Degree 2 environment	
Corrosive Gas	Free of corrosive gases	
Atmospheric Pressure (Operating Altitude)	800...1,114 hPa (2,000 m [6,561 ft] or lower)	
Vibration and Shock Resistance	IEC/EN 61131-2 compliant	
Electrostatic Discharge Immunity	Contact Discharge Method: 6 kV (IEC/EN 61000-4-2 Level 3)	
Weight ^{*4}	3kg (6.6 lb) or less	
External Dimensions ^{*3}	W308.5 x H230.5 x D67mm (W12.15 x H9.07 x D2.64 in.)	
Panel Cut Dimensions	W295 x H217 mm (W11.61 x H8.54 in.)	

External Dimensions

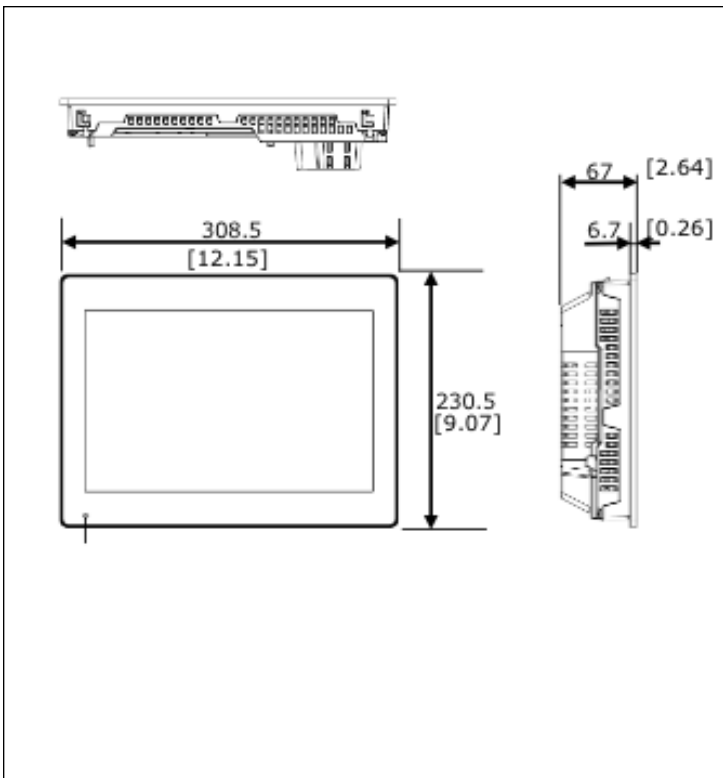

Panel-Cut Out Dimensions

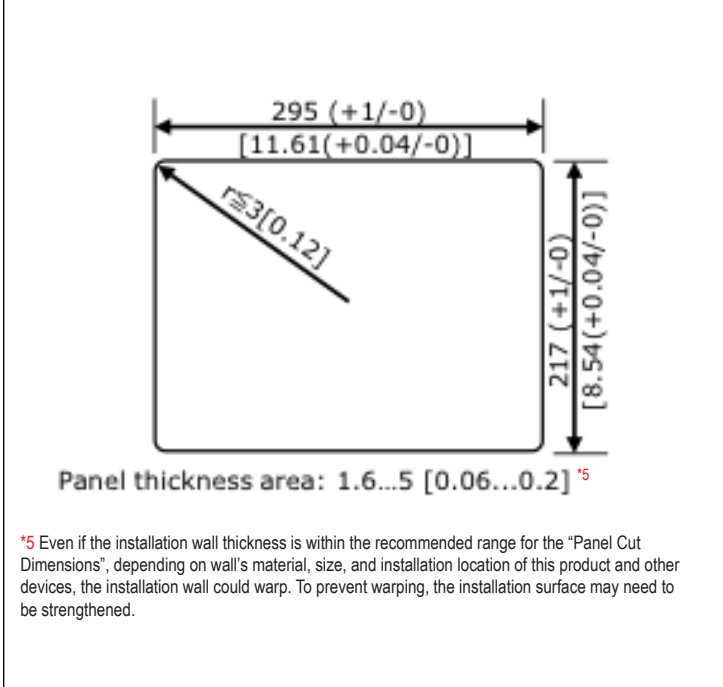

Pro-face America
 Phone: 734.477.0600
 www.profaceamerica.com

Ordering Information

Type	Model Numbers	Description
SP-5600WA	PFXSP5600WAD	12-inch TFT, 262,144 colors, WVGA 1280 x 800 pixels, Analog Touch Panel,
SP-5600WA Conformal Coating	PFXSP5600WADF0C	12-inch TFT, 262,144 colors, WVGA 1280 x 800 pixels, Analog Touch Panel, with conformal coating

Options

Part Number	Product Name	Description
PFXZCDDS12	12-inch Wide Screen Protection Sheet	Disposable, dirt-resistant sheet for the display (5 sheets/set)
PFXZCDWG12	12-inch Wide Installation Gasket.	Provides dust and moisture resistance when SP is installed into a solid panel (1 piece)

Modular Design and Easy Maintenance

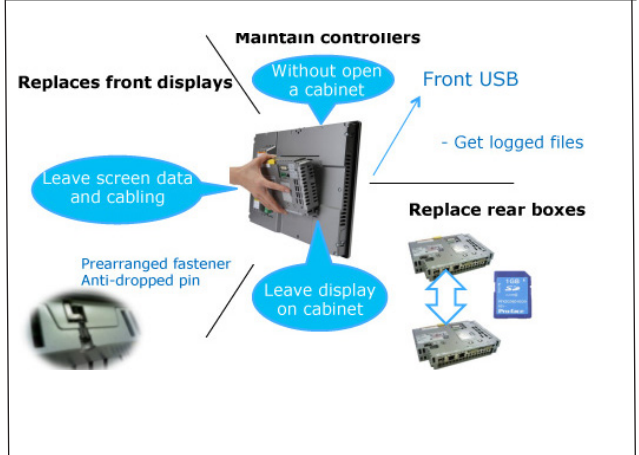

Customer Service Hotline: 800.289.9266

For more information
ACCESS www.profaceamerica.com





California Proposition 65 Warning—Lead and Lead Compounds

Advertencia de la Proposición 65 de California—Plomo y compuestos de plomo

Avertissement concernant la Proposition 65 de Californie—Plomb et composés de plomb

⚠ WARNING: This product can expose you to chemicals including lead and lead compounds, which are known to the State of California to cause cancer and birth defects or other reproductive harm. For more information go to: www.P65Warnings.ca.gov.

⚠ ADVERTENCIA: Este producto puede exponerle a químicos incluyendo plomo y compuestos de plomo, que es (son) conocido(s) por el Estado de California como causante(s) de cáncer y defectos de nacimiento u otros daños reproductivos. Para mayor información, visite : www.P65Warnings.ca.gov.

⚠ AVERTISSEMENT: Ce produit peut vous exposer à des agents chimiques, y compris plomb et composés de plomb, identifiés par l'État de Californie comme pouvant causer le cancer et des malformations congénitales ou autres troubles de l'appareil reproducteur. Pour de plus amples informations, prière de consulter: www.P65Warnings.ca.gov.

All trademarks are the property of Schneider Electric SE, its subsidiaries, and affiliated companies.

Schneider Electric USA, Inc.
800 Federal Street
Andover, MA 01810 USA
888-778-2733
www.schneider-electric.us

Todas las marcas comerciales son propiedad de Schneider Electric SE, sus filiales y compañías afiliadas.

Importado en México por:
Schneider Electric México, S.A. de C.V.
Av. Ejercito Nacional No. 904
Col. Palmas, Polanco 11560 México, D.F.
55-5804-5000
www.schneider-electric.com.mx

Toutes les marques commerciales sont la propriété de Schneider Electric SE, ses filiales et compagnies affiliées.

Schneider Electric Canada, Inc.
5985 McLaughlin Road
Mississauga, ON L5R 1B8 Canada
800-565-6699
www.schneider-electric.ca