

SP-5700TP Premium Display

SP5000 SERIES



Features:

- XGA Display TFT Touch Panel
- 16 million colors
- Compatible with power or open box modules
- USB access via front bezel
- Auto-scaling functionality
- Embedded mounting clips for easy installation

Performance Specifications

Model	SP-5700TP	
Part Number	PFXSP5700TPD	PFXSP5700TPDF0C
Graphics Display Resolution	1,024 x 768 pixels XGA	
Display Type and Size	TFT Color LCD 15"	
Display Colors	16 Million Color	
Effective Display Area	W304.1 x H228.1 mm (W11.97 x H8.98 in.)	
Touch Screen	Resistive film (analog, multi-touch)	
Backlight	White LED	
Backlight Service Life	50,000 hours or more (continuous operation at 25 °C [77 °F] before backlight brightness decreases to 50%)	
Brightness	Max.:400cd(Typ) Min.:4cd(Typ) 0...100 (Adjusted with touch panel or software) ^{*1}	
Front USB	Type A (V2.0) x1, Mini B (V2.0) x1	

^{*1} The maximum and minimum brightness Value is the reference Value, because there are individual differences by the liquid crystal.

General Specifications

Models	SP-5500TP	
Part Number	PFXSP5700TPD	PFXSP5700TPDF0C
Conformal Coating	-	Yes
Input Voltage	12-24 Vdc (limits 10.8 -29.9 Vdc)	
Voltage Drop	12 Vdc: 1.25 ms or less/ 24 Vdc: 5 ms or less	
In-Rush Current	30 A or less	
Voltage Endurance	1,000 Vac, 20 mA for 1 minute (between charging and FG terminals)	
Insulation Resistance	500 Vdc, 10 MQ or more (between charging and FG terminals)	
Power Consumption	57W or less (display module with box module) ^{*1} 22W or less (display module only)	
Surrounding Air Temperature	0...60 °C [32...140 °F]	
Storage Temperature	-20...60 °C [-4...140 °F]	
Certifications	CE, ATEX, RoHS, GOST-R, UL 508/c-UL, CSA C22.2 N°142, KC, EAC, ABS, BV, CCS, DNV, GL, LR, RINA, NK	
Ratings	IP65 (IP65F, IP66F or IP67F, when use enhanced front USB cover), EN61000-6-4, EN61000-6-2, CSA C22.2N°213, ANSI/ISA 12.12.01, Class 1 Div 2 Groups A, B, C, and D when installed as directed.	
Surrounding Air and Storage Humidity	10%...90% RH (Non condensing, wet bulb temperature 39 °C [102.2 °F] or less)	
Dust	0.1 mg/m ³ (10-7 oz/ft ³) or less (non-conductive levels)	
Pollution Degree	For use in Pollution Degree 2 environment	
Corrosive Gas	Free of corrosive gases	
Atmospheric Pressure (Operating Altitude)	800...1,114 hPa (2,000 m [6,561 ft] or lower)	
Vibration and Shock Resistance	IEC/EN 61131-2 compliant	
Electrostatic Discharge Immunity	Contact Discharge Method: 6 kV (IEC/EN 61000-4-2 Level 3)	
Weight	4.5kg (9.9 lb) or less	
External Dimensions	W397 x H296 x D67 mm(W15.6 x H11.7 x D2.64 in.)	
Panel Cut Dimensions	W383.5 x H282.5 mm(W15.1 x H11.12 in.) ^{*2} Panel thickness area:1.6...5 mm (0.06...0.2 in.) ^{*3}	
Warranty	Two (2) years	

^{*1} The power consumption for the combined unit of Box Module and Display Module equals the sum of the power consumption for the Modules. ^{*2} Even if the installation wall thickness is within the recommended range for the "Panel Cut Dimensions", depending on wall's material, size, and installation location of this product and other devices, the installation wall could warp. To prevent warping, the installation surface may need to be strengthened.^{*3} The weight for the combined unit of Box Module and Display Module equals the sum of the weight for the Modules.

External Dimensions

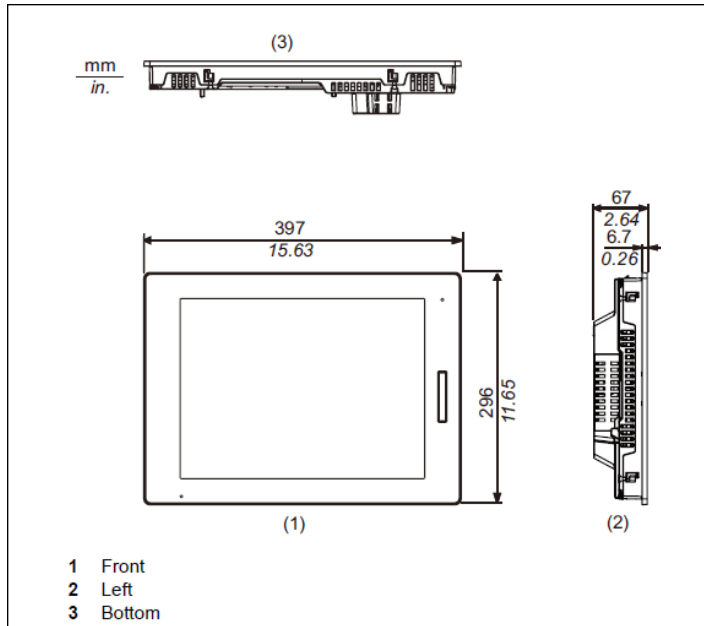

Panel Cut Dimensions

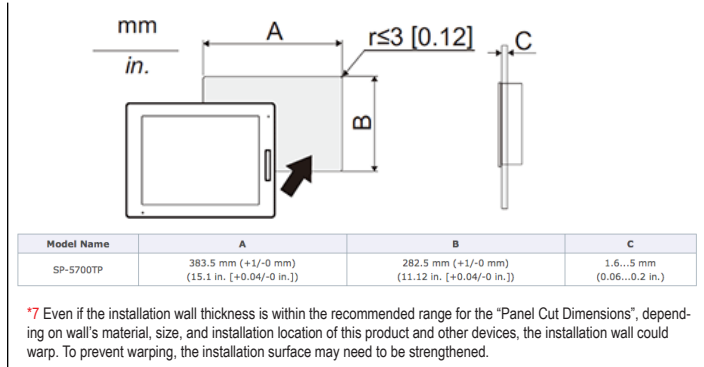

Multiple Screen Size Options

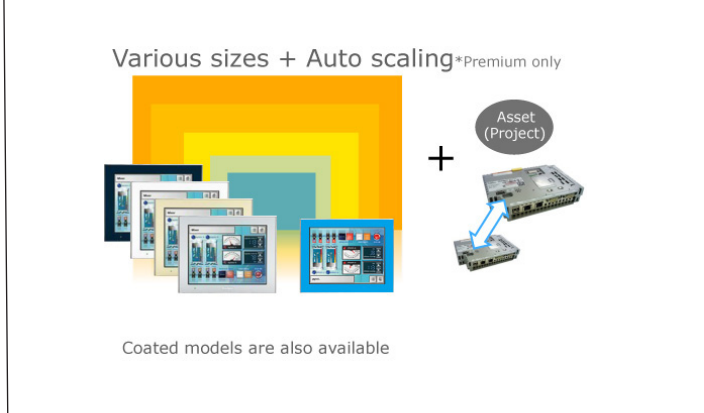

Ordering Information

Type	Model Numbers	Description
SP-5700TP	PFXSP5700TPD	15-inch TFT, 16M colors, XGA 1024 x 768 pixels, Analog Touch Panel(Multi touch), Front USB A/mini-B I/F x 1 each, DC24V
SP-5700TP with Conformal Coating	PFXSP5700TPDF0C	15-inch TFT, 16M colors, XGA 1024 x 768 pixels, Analog Touch Panel(Multi touch), Front USB A/mini-B I/F x 1 each, DC24V with conformal coating

Options

Part Number	Product Name	Description
PFXZCDCVUS1	Enhanced Front USB Cover (With Screw)	Front USB cover with fixing screw, corresponding to IP66F, IP67F, Type 1/4X Indoor use only /I3 or ATEX certification (5 pieces/set)
PFXZCDWG151	15-inch Installation Gasket	Provides dust and moisture resistance when SP is installed into a solid panel (1 piece)

Modular Design and Easy Maintenance

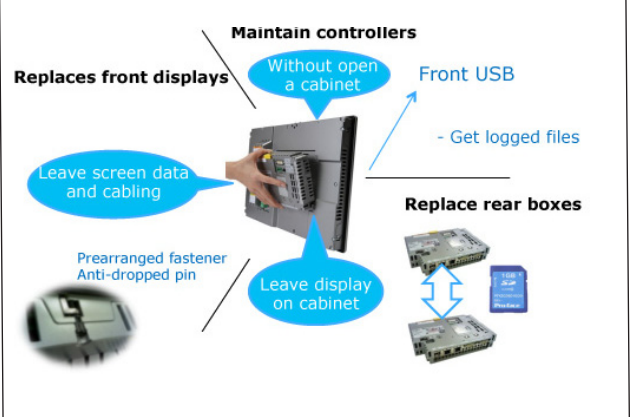

Pro-face America
 Phone: 734.477.0600
 Fax: 734.864.7347
 www.profaceamerica.com

Customer Service Hotline: 800.289.9266

For more information
ACCESS www.profaceamerica.com

Pro-face



California Proposition 65 Warning—Lead and Lead Compounds

Advertencia de la Proposición 65 de California—Plomo y compuestos de plomo

Avertissement concernant la Proposition 65 de Californie—Plomb et composés de plomb

⚠ WARNING: This product can expose you to chemicals including lead and lead compounds, which are known to the State of California to cause cancer and birth defects or other reproductive harm. For more information go to: www.P65Warnings.ca.gov.

⚠ ADVERTENCIA: Este producto puede exponerle a químicos incluyendo plomo y compuestos de plomo, que es (son) conocido(s) por el Estado de California como causante(s) de cáncer y defectos de nacimiento u otros daños reproductivos. Para mayor información, visite : www.P65Warnings.ca.gov.

⚠ AVERTISSEMENT: Ce produit peut vous exposer à des agents chimiques, y compris plomb et composés de plomb, identifiés par l'État de Californie comme pouvant causer le cancer et des malformations congénitales ou autres troubles de l'appareil reproducteur. Pour de plus amples informations, prière de consulter: www.P65Warnings.ca.gov.

All trademarks are the property of Schneider Electric SE, its subsidiaries, and affiliated companies.

Schneider Electric USA, Inc.
800 Federal Street
Andover, MA 01810 USA
888-778-2733
www.schneider-electric.us

Todas las marcas comerciales son propiedad de Schneider Electric SE, sus filiales y compañías afiliadas.

Importado en México por:
Schneider Electric México, S.A. de C.V.
Av. Ejercito Nacional No. 904
Col. Palmas, Polanco 11560 México, D.F.
55-5804-5000
www.schneider-electric.com.mx

Toutes les marques commerciales sont la propriété de Schneider Electric SE, ses filiales et compagnies affiliées.

Schneider Electric Canada, Inc.
5985 McLaughlin Road
Mississauga, ON L5R 1B8 Canada
800-565-6699
www.schneider-electric.ca