

SP-5790WA eXtreme Display

SP5000X SERIES



Features:

- FWXGA Display TFT Touch Panel
- 262,144 colors
- Class 1 Div 2, Groups A, B, C, and D
- IP66F Front Panel (with proper panel install)
- Easily combine with SP-5B90 eXtreme Box
- NEMA 4X Outdoor Rated (3C3 model)• Sunlight Readable and Anti-glare Surface
- UV Resistive (Front Side)

Performance Specifications

Model	SP-5790WA eXtreme Display	
Part Number	PFXSP5790WAD	PFXSP5790WADF0H
For use in Harsh and Corrosive Environments (3C3)	No	Yes
Graphics Display Resolution	1,366 x 768 pixels (FWXGA)	
Display Type and Size	TFT Color LCD 15" wide	
Display Colors	262,144 colors	
Effective Display Area	344.2 x 193.5 mm [13.55 x 7.62 in]	
Touch Screen	Analog resistive	
Backlight	White LED (Not user replaceable. When replacement is required, contact your local distributor.)	
Brightness	1000 cd/m2 (typ.) or 1000 NITs	

General Specifications

Part Number	PFXSP5790WAD, PFXSP5790WADF0H
Rated Input Voltage and Input Voltage Limits	12...24 Vdc and 10.8 to 28.8 Vdc
Voltage Drop	12 Vdc: 1.25 ms or less, 24 Vdc: 5 ms or less
In-Rush Current	30 A or less
Voltage Endurance	1,000 Vac, 20 mA for 1 minute (between charging and FG terminals)
Insulation Resistance	500 Vdc, 10 MQ or more (between charging and FG terminals)
Power Consumption ¹	48 W (max), 34W or less (When power is not supplied to external devices), 12.5W or less (When screen turns off the backlight (Standby Mode)) 19 W or less (When screen backlight 20%)
Ambient Air Temperature ²	-20 to 60 °C (-4 to 140 °F) When installing and wiring: -5 to 60 °C (23 to 140 °F)
Storage Temperature ²	-20 to 60 °C [-4 to 140 °F]
Certifications	UL 61010-2-201 and CSA C22.2 No61010-2-201, ANSI/ISA 12.12.01 and CSA C22.2 No213, Electrical Equipment for Use in Class 1, Division 2 Hazardous (Classified) Locations, IECEx / ATEX for use in zones 2/22, EN60079-0 EN60079-15, EN60079-31 EAC, CE, AS/NZS CISPR11 (EN55011), KC, RoHS
Structure ³	IP66F, IP67F, Type 4X (indoor and outdoor use), Type 12, Type13 ⁵ * on the front panel when properly installed in an enclosure.
Surrounding Air and Storage Humidity	10%...90% RH (Non condensing, wet bulb temperature 39 °C [102.2 °F] or less)
Dust	0.1 mg/m3 (10-7 oz/ft3) or less (non-conductive levels)
Pollution Degree	3 for front face, 2 for other sides
Corrosive Gas ²	IEC/EN 60721-3-3 Class 3C3
Atmospheric Pressure (Operating Altitude)	800...1,114 hPa (2,000 m [6,561 ft] or lower)
UV resistance (front side)	Cutoff: 99% or more (380 nm)
Vibration and Shock Resistance	IEC 60068-2-6 compliant 5 to 9 Hz Single amplitude 3.5 mm (0.14 in) 9 to 150 Hz Fixed acceleration: 9.8 m/s2 X, Y, Z directions for 10 cycles (approximately 100 minutes) IEC 61373: 1999 (Category 1, Class B) 5≤f≤150 Hz (weight < 500 kg: f1=5 Hz, f2=150 Hz) acceleration: Up and down: 7.90 m/s2, Right and left: 3.50 m/s2. Shock Resistance: Back and forward: 5.50 m/s2, IEC 60068-2-27 compliant 147 m/s2, 11 ms, X, Y, Z directions for 3 times
Electrostatic Discharge Immunity	Contact discharge method: 6 kV Air discharge method: 8 kV(IEC/EN 61000-4-2 Level 3)
Electronic fast transient/burst immunity	IEC 61000-4-4, 2 kV: Power port, 1 kV: Signal ports
Weight ⁴	4.8 kg (10.6 lb) or less
External Dimensions ³	W408 x H264 x D68 mm [W16.06 x H10.39 x D2.68 in]
Panel Cut Dimensions	W394 x H250 mm [15.51 x 9.84 in] Panel thickness area: 1.6 to 5 mm [0.06 to 0.2 in]
Warranty	Two (2) years

1. Power consumption is measured with the display on and the backlight on. 2. Ambient air temperature is measured at the front panel. 3. Dimensions are measured at the front panel. 4. Weight is measured at the front panel. 5. Type 13 is not available for the front panel. * Type 13 is available for the back panel. ©2020 Pro-face. All rights reserved. Specifications may change without notice.

External Dimensions

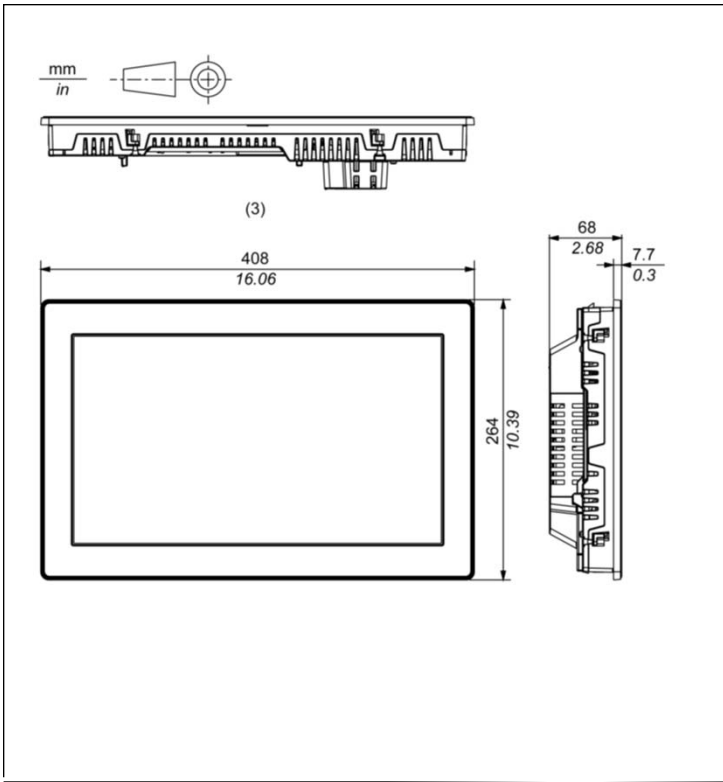

Panel-Cut Out Dimensions

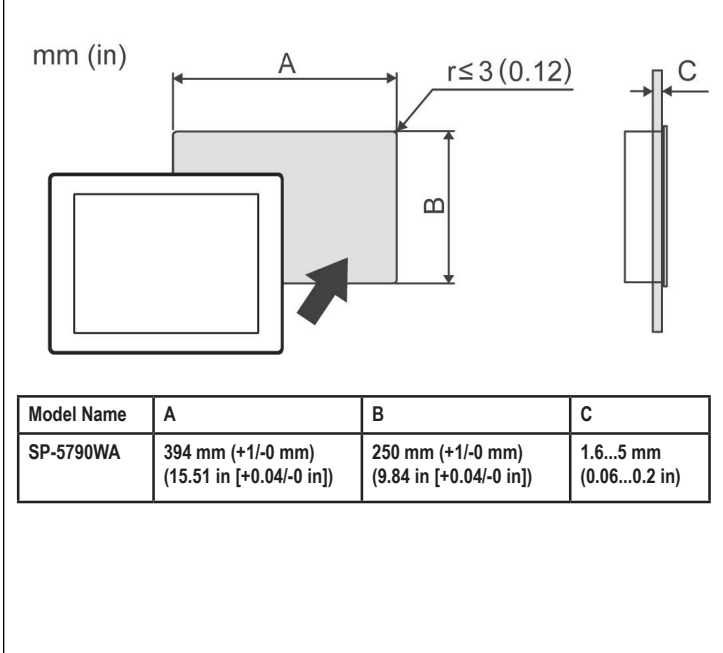

Ordering Information and Options

Model Number	Description
PFXSP5790WAD	15-inch Wide, Outdoor use, Rugged, UV protected, Coated, Sunlight readable TFT, 262,000 colors, FWXGA 1,366 x 768 pixels, Analog Touch Panel, DC12-24V
PFXSP5790WADF0H	15-inch Wide, Outdoor use, Rugged, UV protected, Coated, Sunlight readable TFT, 262,000 colors, FWXGA 1,366 x 768 pixels, Analog Touch Panel, DC12-24V, plus harsh and corrosive environments
PFXSP5B90	SP5000X Series eXtreme Box Outdoor use, Rugged, Coated, Ethernet I/F x 2, COM I/F x 2, USB A I/F x 2, USB mini-B I/F, SD Card I/F x 2, AUX I/F, Expansion Unit I/F

Options

Part Number	Description
PFXZCHBMFBL1	SP5000X Series, Bracket for fixing Box module to Display module (1 piece)
PFXZCHCND3	Connector with fixable screws to connect DC power supply cables for 12" and 15" display (Angle type, 5pcs/set)
PFXZCHEUJ1	Expansion unit that enables participation of the SP5000 Series/SP5000X Series in the J1939 communication network
PFXZCHWG154	15" Display cover provides dust and moisture resistance when this product is installed into a solid panel (1 piece)

EXTREME Solutions



Oil & Gas



Water/Waste Water



Pumping Station



Transportation

Pro-face America
 Phone: 734.477.0600
 www.profaceamerica.com

Customer Service Hotline: 800.289.9266

For more information
ACCESS www.profaceamerica.com

