

STW-6700WA Basic Web Terminal



Features:

- Aluminum Front Panel
- 16 Million Colors
- Enhanced Cybersecurity
- Easy to Install, No Tools Needed
- Single Touch Analog Display
- 2 Ethernet Ports

Performance Specifications

Model	STW6700WA	
Graphics Display Resolution	FWXGA TFT (1,366 x 768 Pixels)	
Display Type and Size	TFT Color LCD (15.6-inch) Wide	
Display Colors	16 million colors	
Touch Panel	Resistive film (analog, single touch)	
Effective Display Area	344.23 x 193.54 mm (13.55 x 7.62 in)	
ToucPanel Resolution	1024 x 1024	
Backlight	Backlight White LED (Not user replaceable. When replacement is required, contact customer support.)	
Backlight Service Life	50,000 hours or more (continuous operation at 25 °C [77 °F] before backlight brightness decreases to 25%)	
Brightness Control	16 levels (Adjusted with touch panel or software)	
Interface	USB (Type A)	Connector: USB 2.0 (Type A) x 1, Power supply voltage: 5 Vdc ±5 %, Maximum current supplied: 500 mA, Communication distance: 5 m [16.4 ft.]
	USB (Type - microB)	The USB (micro-B) interface is disabled.
	Ethernet	IEEE802.3i/IEEE802.3u, 10BASE-T/100BASE-TX, Connector: Modular jack (RJ-45) x 2 ^{*1}

¹ ETH1 and ETH2 have the same IP address and MAC address.

General Specifications

Model	STW6700WA
Input Voltage	Rated Input Voltage: 24 Vdc / Input Voltage Limits: 19.2 to 28.8 Vdc
Power Consumption	15 W or less when power is not supplied to devices via from USB, 5.4 W or less when screen turns off the backlight (standby mode) (Max 18.5 W)
In-Rush Current	30 A or less
Storage Temperature	-20 to 60 °C (-4 to 140 °F)
Shock Resistance	IEC/EN 61131-2 compliant 147 m/s ² , X, Y, Z directions for 3 times
Certifications	UL 61010-2-201 and CSA C22.2 No61010-2-201, KC KN1, KN61000-6-2, RCM EN61000-6-4, CE EN 61131-2, EN61000-6-4, EN61000-6-2, RoHS, REACH Regulation EC 1907/2006, WEEE Directive 2012/19/EU
Operating Temperature	0 to 50 °C (32 to 122 °F)
Voltage Drop	10 ms or less
Corrosive Gas	Free of corrosive gases
Pollution Degree	For use in pollution degree 2 environment
Cooling method	Natural air circulation
Dust	0.1 mg/m ³ (10 ⁻⁷ oz/ft ³) or less (non-conductive levels)
Voltage Endurance	1,000 Vac, 20 mA for 1 minute (between charging and FG terminals)
Vibration Resistance	IEC/EN 61131-2 compliant, 5 to 9 Hz single amplitude 3.5 mm [0.14 in.], 9 to 150 Hz fixed acceleration: 9.8 m/s ² , X, Y, Z directions for 10 cycles (approx. 100 min.)
Insulation Resistance	500 Vdc, 10 MΩ or more
Structure	IP65F, Type 1, Type 4X (indoor use only), Type 13 (on the front panel when properly installed in an enclosure) ^{*2}
Weight	2.7 kg (5.95 lb) or less
External Dimensions	412 x 268 x 50 mm (16.22 x 10.55 x 1.97 in)
Panel Cut-Out Dimensions	394 x 250 mm (15.51 x 9.84 in) ^{*2} Panel thickness area: 1.6...5 mm (0.06...0.2 in) ^{*3}
Warranty	Two (2) years

² For dimensional tolerance, everything +1/-0 mm (+0.04/-0 in) and R in angle are below R3 (R0.12 in)

³ Even if the installation wall thickness is within the recommended range for the "Panel Cut Dimensions", depending on wall's material, size, and installation location of this product and other

External Dimensions

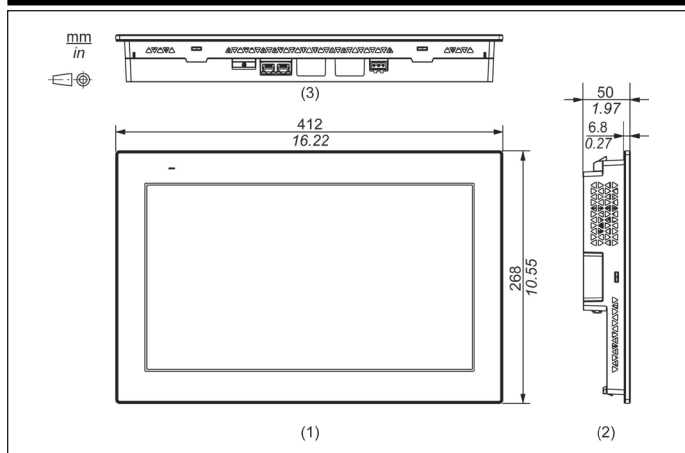

Ordering Information

Model Number	Description
PFXSTW6700WAD	15.6"W Basic Web Terminal 15.6"W 1366 x 768 pixel 16M colors display with analog signal touch panel, Ethernet(RJ45) x 2, USB Host, 24VDC, non-expandable

Panel Cut-Out Dimensions

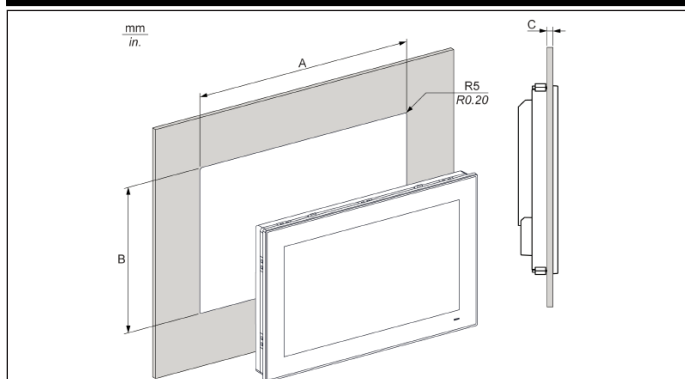

Options

Part Number	Description
PFXZCIAFTF1	Installation fastener (2 pieces/set).
PFXZCIWG153	Installation Gasket
CA5-DCCNM-01	Connector to connect DC power supply cables.
PFXZCIDS152	Disposable, dirt-resistant sheet for the display (5 sheets/set) for STW-6700WA.
FP-US00	Connects a USB device.
CA5-USBEXT-01	Extension cable that attaches USB interface to front panel.
PFXZCBCLUSA1	Clamp to prevent disconnection of USB cable (USB Type A, 1 port, 5 clamps/set)

Panel Cut Out	A	B	C
15.6" Wide	394 ±0.7 mm (15.51 ±0.03 in.)	250 ±0.4 mm (9.84 ±0.02 in.)	1.6 to 5 mm (0.06 to 0.2 in.)

Pro-face America

Phone: 734.477.0600

Fax: 734.864.7347

www.profaceamerica.com

Customer Service Hotline: 800.289.9266

For more information

ACCESS www.profaceamerica.com



California Proposition 65 Warning—Lead and Lead Compounds

Advertencia de la Proposición 65 de California—Plomo y compuestos de plomo

Avertissement concernant la Proposition 65 de Californie—Plomb et composés de plomb

⚠ WARNING: This product can expose you to chemicals including lead and lead compounds, which are known to the State of California to cause cancer and birth defects or other reproductive harm. For more information go to: www.P65Warnings.ca.gov.

⚠ ADVERTENCIA: Este producto puede exponerle a químicos incluyendo plomo y compuestos de plomo, que es (son) conocido(s) por el Estado de California como causante(s) de cáncer y defectos de nacimiento u otros daños reproductivos. Para mayor información, visite : www.P65Warnings.ca.gov.

⚠ AVERTISSEMENT: Ce produit peut vous exposer à des agents chimiques, y compris plomb et composés de plomb, identifiés par l'État de Californie comme pouvant causer le cancer et des malformations congénitales ou autres troubles de l'appareil reproducteur. Pour de plus amples informations, prière de consulter: www.P65Warnings.ca.gov.

All trademarks are the property of Schneider Electric SE, its subsidiaries, and affiliated companies.

Schneider Electric USA, Inc.
800 Federal Street
Andover, MA 01810 USA
888-778-2733
www.schneider-electric.us

Todas las marcas comerciales son propiedad de Schneider Electric SE, sus filiales y compañías afiliadas.

Importado en México por:
Schneider Electric México, S.A. de C.V.
Av. Ejercito Nacional No. 904
Col. Palmas, Polanco 11560 México, D.F.
55-5804-5000
www.schneider-electric.com.mx

Toutes les marques commerciales sont la propriété de Schneider Electric SE, ses filiales et compagnies affiliées.

Schneider Electric Canada, Inc.
5985 McLaughlin Road
Mississauga, ON L5R 1B8 Canada
800-565-6699
www.schneider-electric.ca