



Easy! Smooth!

Replacement Guidebook

GP-3300T/S/L Control Class (DIO Type) → STC-6300TA

The 2nd Edition August 2024

SE01-Guide-GP3300DIOtoSTC6300TA-EN-02

*Products may be changed or discontinued without notice. Please check our website for the latest information.

Update History

Date	Edition	Updated Slide	Description
2024/03/08	1 st	-	Newly created
2024/08/23	2 nd	44	Added information of the workarounds for Blink function on STC6000 Series

Legal Information

The Pro-face brand and any trademarks of Schneider Electric SE and its subsidiaries referred to in this guide are the property of Schneider Electric SE or its subsidiaries. All other brands may be trademarks of their respective owners.

This guide and its content are protected under applicable copyright laws and furnished for informational use only. No part of this guide may be reproduced or transmitted in any form or by any means (electronic, mechanical, photocopying, recording, or otherwise), for any purpose, without the prior written permission of Schneider Electric.

Schneider Electric does not grant any right or license for commercial use of the guide or its content, except for a non-exclusive and personal license to consult it on an "as is" basis. Schneider Electric products and equipment should be installed, operated, serviced, and maintained only by qualified personnel.

As standards, specifications, and designs change from time to time, information contained in this guide may be subject to change without notice.

To the extent permitted by applicable law, no responsibility or liability is assumed by Schneider Electric and its subsidiaries for any errors or omissions in the informational content of this material or consequences arising out of or resulting from the use of the information contained herein.

As part of a group of responsible, inclusive companies, we are updating our communications that contain non-inclusive terminology. Until we complete this process, however, our content may still contain standardized industry terms that may be deemed inappropriate by our customers.

Safety Information

Important Information

Read these instructions carefully and look at the equipment to become familiar with the device before trying to install, operate, service, or maintain it. The following special messages may appear throughout this documentation or on the equipment to warn of potential hazards or to call attention to information that clarifies or simplifies a procedure.



The addition of this symbol to a “Danger” or “Warning” safety label indicates that an electrical hazard exists which will result in personal injury if the instructions are not followed.



This is the safety alert symbol. It is used to alert you to potential personal injury hazards. Obey all safety messages that follow this symbol to avoid possible injury or death.

DANGER

DANGER indicates a hazardous situation which, if not avoided, **will result in** death or serious injury.

CAUTION

CAUTION indicates a hazardous situation which, if not avoided, **could result** in minor or moderate injury.

WARNING

WARNING indicates a hazardous situation which, if not avoided, **could result in** death or serious injury.

NOTICE

NOTICE is used to address practices not related to physical injury.

Please Note

Electrical equipment should be installed, operated, serviced, and maintained only by qualified personnel. No responsibility is assumed by Schneider Electric for any consequences arising out of the use of this material.

A qualified person is one who has skills and knowledge related to the construction and operation of electrical equipment and its installation and has received safety training to recognize and avoid the hazards involved.

About this book

Document Scope

This guidebook introduces the procedures to replace a unit from “GP3300T/S/L Control Class (DIO Type)” to “STC6000 Series”. The recommended substitute models are as follows.

Model in use			Recommended substitutes		
GP-3300T/S/L Control Class DIO Type	GP-3300T	PFXGP3300TADDK (AGP3300-T1-D24-D81K)	→	STC-6300TA (Digital Output Sink Type)	PFXSTC6300TADDKE
		PFXGP3300TADDC (AGP3300-T1-D24-D81C)	→	STC-6300TA (Digital Output Source Type)	PFXSTC6300TADDCE
	GP-3300S	PFXGP3300SADDK (AGP3300-S1-D24-D81K)	→	STC-6300TA (Digital Output Sink Type)	PFXSTC6300TADDKE
		PFXGP3300SADDC (AGP3300-S1-D24-D81C)	→	STC-6300TA (Digital Output Source Type)	PFXSTC6300TADDCE
	GP-3300L	PFXGP3300LADDK (AGP3300-L1-D24-D81K)	→	STC-6300TA (Digital Output Sink Type)	PFXSTC6300TADDKE
		PFXGP3300LADDC (AGP3300-L1-D24-D81C)	→	STC-6300TA (Digital Output Source Type)	PFXSTC6300TADDCE

About this book

Validity Note

This documentation is valid for this product.

The technical characteristics of the device(s) described in the present manual also appear online at www.pro-face.com.

The characteristics that are described in the present document should be the same as those characteristics that appear online. In line with our policy of constant improvement, we may revise content over time to improve clarity and accuracy. If you see a difference between the document and online information, use the online information as your reference.

Registered Trademarks

Product names used in this manual may be the registered trademarks owned by the respective proprietors.

Related Documents

You can download the manuals related to this product, such as the software manual, from our website.

<https://www.proface.com/en/download/search>

Product Related Information

If the equipment is used in a manner not specified by the manufacturer, the protection provided by the equipment may be impaired.

About this book

⚠️⚠️ DANGER

HAZARD OF ELECTRIC SHOCK, EXPLOSION, OR ARC FLASH

- Remove all power from the device before removing any covers or elements of the system, and prior to installing or removing any accessories, hardware, or cables.
- Unplug the power cable from both this product and the power supply prior to installing or removing the product.
- Always use a properly rated voltage sensing device to confirm power is off where and when indicated.
- Replace and secure all covers or elements of the system before applying power to this product.
- Use only the specified voltage when operating this product. This product is designed to use 24 Vdc. Always check whether your device is DC powered before applying power.
- When using this product in Class I, Division 2, Groups A, B, C, and D hazardous locations, install this product in an enclosure that prevents the operator from touching the back of this product without the use of tools.

Failure to follow these instructions will result in death or serious injury.

Critical alarm indicators and system functions require independent and redundant protection hardware and/or mechanical interlocks.

When you cycle power, wait at least 10 seconds after it has been turned off. If this product is restarted too quickly, it may not operate correctly.

In the event the screen cannot be properly read, for example, if the backlight is not functioning, it may be difficult or impossible to identify a function. Functions that may present a hazard if not immediately executed, such as a fuel shut-off, must be provided independently of this product. The machine's control system design must take into account the possibility of the backlight no longer functioning and the operator being unable to control the machine or making mistakes in the control of the machine.

⚠️ WARNING

LOSS OF CONTROL

- The designer of any control scheme must consider the potential failure modes of control paths and, for certain critical control functions, provide a means to achieve a safe state during and after a path failure. Examples of critical control functions are emergency stop and overtravel stop, power outage and restart.
- Separate or redundant control paths must be provided for critical control functions.
- System control paths may include communication links. Consideration must be given to the implications of unanticipated transmission delays or failures of the link.
- Observe all accident prevention regulations and local safety guidelines.
- Each implementation of this product must be individually and thoroughly tested for proper operation before being placed into service.
- The machine control system design must take into account the possibility of the backlight no longer functioning and the operator being unable to control the machine, or making errors in the control of the machine.

Failure to follow these instructions can result in death, serious injury, or equipment damage.

For additional information, refer to NEMA ICS 1.1 (latest edition), "Safety Guidelines for the Application, Installation, and Maintenance of Solid State Control" and to NEMA ICS 7.1 (latest edition), "Safety Standards for Construction and Guide for Selection, Installation and Operation of Adjustable-Speed Drive Systems" or their equivalent governing your particular location.

⚠️ WARNING

UNINTENDED EQUIPMENT OPERATION

- The application of this product requires expertise in the design and programming of control systems. Only persons with such expertise should be allowed to program, install, alter, and apply this product.
- Follow all applicable safety standard, local regulations and directives.

Failure to follow these instructions can result in death, serious injury, or equipment damage.

About this book

⚠ WARNING

UNINTENDED EQUIPMENT OPERATION

- Do not use this product as the only means of control for critical system functions such as motor start/stop or power control.
- Do not use this equipment as the only notification device for critical alarms, such as device overheating or overcurrent.
- Use only the software provided with this product. If you use other software, please confirm the operation and safety before use.

Failure to follow these instructions can result in death, serious injury, or equipment damage.

The following characteristics are specific to the LCD panel and are considered normal behavior:

- LCD screen may show unevenness in the brightness of certain images or may appear different when seen from outside the specified viewing angle. Extended shadows, or crosstalk may also appear on the sides of screen images.
- LCD screen pixels may contain black and white colored spots and color display may seem to have changed.
- When experiencing vibrations within a certain frequency range and vibration acceleration is above what is acceptable, the LCD screen may partially turn white. Once the vibration condition ends, the whitening of the screen is resolved.
- When the same image is displayed on the screen for a long period, an afterimage may appear when the image is changed.
- The panel brightness may decrease when used for a long time in an environment continuously filled with inert gas. To prevent deterioration of panel brightness, regularly ventilate the panel. For more information, please contact customer support.

<https://www.pro-face.com/trans/en/manual/1015.html>

⚠ WARNING

SERIOUS EYE AND SKIN INJURY

The liquid in the LCD panel contains an irritant:

- Avoid direct skin contact with the liquid.
- Wear gloves when you handle a broken or leaking unit.
- Do not use sharp objects or tools in the vicinity of the LCD panel.
- Handle the LCD panel carefully to prevent puncture, bursting, or cracking of the panel material.
- If the panel is damaged and any liquid comes in contact with your skin, immediately rinse the area with running water for at least 15 minutes. If the liquid gets in your eyes, immediately rinse your eyes with running water for at least 15 minutes and consult a doctor.

Failure to follow these instructions can result in death, serious injury, or equipment damage.

NOTICE

REDUCTION OF SERVICE LIFE OF PANEL

Change the screen image periodically and try not to display the same image for a long period of time.

Failure to follow these instructions can result in equipment damage.

Cybersecurity

Cybersecurity Guideline

Use this product inside a secure industrial automation and control system. Total protection of components (equipment/devices), systems, organizations, and networks from cyber attack threats requires multi-layered cyber risk mitigation measures, early detection of incidents, and appropriate response and recovery plans when incidents occur. For more information about cybersecurity, refer to the Pro-face HMI/IPC Cybersecurity Guide.

https://www.proface.com/en/download/manual/cybersecurity_guide

⚠ WARNING

POTENTIAL COMPROMISE OF SYSTEM AVAILABILITY, INTEGRITY, AND CONFIDENTIALITY

- Change default passwords at first use to help prevent unauthorized access to device settings, controls and information.
- Disable unused ports/services and default accounts, where possible, to minimize pathways for malicious attacks.
- Place networked devices behind multiple layers of cyber defenses (such as firewalls, network segmentation, and network intrusion detection and protection).
- Apply the latest updates and hotfixes to your Operating System and software.
- Use cybersecurity best practices (for example: least privilege, separation of duties) to help prevent unauthorized exposure, loss, modification of data and logs, interruption of services, or unintended operation.

Failure to follow these instructions can result in death, serious injury, or equipment damage.

Table of Contents

1

[Summary](#)

2

[Hardware Section](#)

2-1

[Specification Comparison](#)

2-2

[Standards Compatibility](#)

2-3

[Interface Compatibility](#)

2-4

[Installation Method Compatibility](#)

2-5

[Option Compatibility](#)

2-6

[Other Important Notes on Hardware](#)

3

[Software Section](#)

3-1

[Replacement Procedure](#)

3-2

[Software Compatibility](#)

3-3

[Other Important Notes on Software](#)

1. Summary

On replacement from GP-3300T/S/L (DIO) to STC-6300TA, the following points are the main points to note.

- STC-6300TA is equipped with DIO as standard, same as GP-3300T/S/L (DIO). Since the I/O driver used are different between GP-3300T/S/L (DIO) and STC-6300TA, the I/O driver settings in GP-Pro EX will not be carried over to STC-6300TA after converting the project. You need to configure the I/O driver settings on the software again.
- The DIO specifications of GP-3300T/S/L(DIO) and STC-6300TA are different. Please note that rewiring is required. For the details, please refer to [STC6000 Hardware Manual](#).
- Display resolution: STC-6300TA has a better resolution. You need to convert resolution by the software to use old project data from GP-3300T/S/L.

GP-3300T/S/L

320 x 240 pixels (QVGA)

STC-6300TA

640 x 480 pixels (VGA)

- External dimensions: The panel cut dimensions are the same, but the external dimensions are slightly different. It is necessary to check the dimensions of the HMI installation location.

GP-3300T/S/L

W167.5 x H135 x D59.5 mm

STC-6300TA

W169.5 x H137 x D60 mm



GP-3300T/S/L



STC-6300TA

Public

2. Hardware Section

2-1. GP-3300T/S/L (DIO) vs STC-6300TA Specification Comparison -1. Basic Information-

		GP-3300T	GP-3300S	GP-3300L	STC-6300TA	Points to note when replacing
Display Type		TFT Color LCD	STN Color LCD	Monochrome LCD	TFT Color LCD	
Display Size		5.7"			5.7"	
Resolution		320 x 240 pixels (QVGA)			640 x 480 pixels (VGA)	Need to change resolution setting by Software
Effective display area (W x H)		115.2 x 86.4 mm			115.2 x 86.4 mm	
Display colors		65,536 colors (no blink) 16,384 colors (with blink)	4,096 colors	Black and White (16 shades)	262,144 colors (no blink)	No blink function
Backlight		White LED (Rev6) CCFL (not Rev6)	CCFL (not user replaceable)		White LED (not replaceable)	Backlight is not replaceable.
Backlight service life		50,000 hours or more (before backlight brightness decreases to 50%)	75,000 hours or more (before backlight brightness decreases to 50%)	58,000 hours or more (before backlight brightness decreases to 50%)	50,000 hours or more (before backlight brightness decreases to 25%)	
Brightness control		8 levels (Adjusted with touch panel or software)			16 levels (Adjusted with touch panel or software)	
Touch panel type		Resistive film (analog, single touch)			Resistive film (analog, single touch)	
Touch panel resolution		1,024 x 1,024			1,024 x 1,024	
Touch panel service life		1 million times or more			1 million times or more	
Application memory	Screen area	FLASH EPROM 6MB			FLASH EPROM 64MB	Refer to FAQ for the available capacity of each memory.
	Logic Program	FLASH EPROM 132KB (15,000 steps)			FLASH EPROM 132KB (15,000 steps)	
Backup memory	Screen area	SRAM 320KB			NVRAM 320KB	
	Variable area	SRAM 64KB			NVRAM 64KB	
	Battery (clock data backup)	Rechargeable battery / Secondary battery for clock data backup			Replaceable battery / Primary battery for clock data backup	Battery can be replaced by user.
Rate Input Voltage		DC24V (Input voltage limits: DC19.2~28.8V)			DC24V (Input voltage limits: DC19.2~28.8V)	
IP Rating		IP65f, NEMA#250 TYPE 4X/13			IP65f, UL 50/50E, TYPE 1/4X/12/13	
External Dimensions		W167.5 x H135 x D77.6 mm			W169.5 x H137 x D60 mm	The dimensions are different.
Panel Cut Dimensions		W156 x H123.5 mm			W156 x H123.5 mm	
Power Consumption		26W or less			11.3W or less	

2-1. GP-3300T/S/L (DIO) vs STC-6300TA Specification Comparison -2. Interface-

		GP-3300T	GP-3300S	GP-3300L	STC-6300TA	Points to note when replacing
Serial I/F	COM1	RS-232C/422/485 (D-Sub 9pin Plug)			RS-232C/422/485 (D-Sub 9pin Plug)	Please refer to 2.5. Other important notes on Hardware in this document.
	COM2	RS-422/485 (D-Sub 9pin Socket)			-	
Ethernet I/F		10BASE-T/100BASE-TX (RJ-45) x1			10BASE-T/100BASE-TX (RJ-45) x1	
USB I/F	Type A	USB 1.1 (Type A) x1 -USB transfer cable (CA3-USBCB-01)			USB 2.0 (Type A) x1	No screen data transfer via Type A
	Micro B	-			USB 2.0 (micro-B) x1 -USB transfer cable(PFXZUSCBMB2) or commercial USB micro-B transfer cable	
CFカード I/F		Yes			-	To keep using the functions that were working with CF Card, use a USB Memory instead.
CANopen I/F		-			CANopen Master Embedded *1	
Expansion Unit I/F		Connect Expansion Unit with communication feature			-	The expansion unit (such as CC-LINK Unit) for GP-3300 series cannot be used.
Expansion Module I/F (TM3 module / EX module)		-			TM3 module / EX module x 1 Up to 2x modules by Direct mounting Up to 8x modules by Extension mounting *2	8x modules are supported with Transmitter / Receiver *2
DIO I/F	Digital IN/OUT	Sink/Source Input 6 points -D81K (Sink output): 2 points -D81C (Source output): 2 points Connector: 12 pin			Sink/Source input: 16 points PFXSTC6300TADDKE (Sink output): 16 points PFXSTC6300TADDCE (source output): 16 points Connector: 38 pin	
	HSC (high speed counter) Max.100kHz	-			4x Fast IN (among 16 IN)	
	PTO (pulse train output) Max. 65kHz	-			4x Fast OUT (among 16 OUT)	

*1: CANopen interface will be supported. Please contact our Customer Service for the latest information.

*2: For Extended mounting, TM3-BUS Transmitter (TM3XTRA1) and Receiver (TM3XREC1) are needed.

NOTE: For more details about specification, please refer to [STC6000 Hardware Manual](#).

2-1-1. DIO Interface Comparison

As the number of pins and pin assignments of DIO connectors are different, rewiring is required.

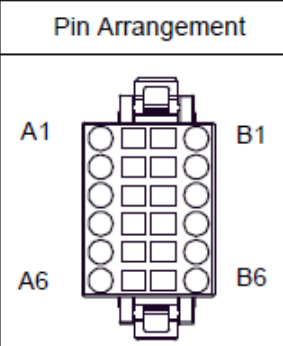
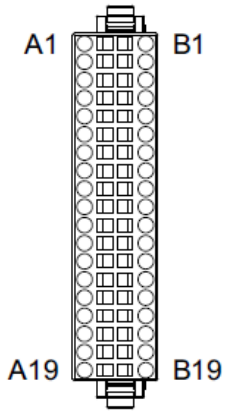
GP-3300T/S/L (DIO)					STC-6300TA																																																																																																																						
12 pin connector (P/N: CA6-DIOCNALL-01)					38 pin connector (P/N: PFXZC7CNXY321)																																																																																																																						
 <table border="1"> <thead> <tr> <th>Pin Arrangement</th> <th>Pin No.</th> <th>Signal Name</th> <th>Pin No.</th> <th>Signal Name</th> </tr> </thead> <tbody> <tr> <td>A1</td> <td>A1</td> <td>0V</td> <td>B1</td> <td>+24V</td> </tr> <tr> <td>B1</td> <td>A2</td> <td>OUT1</td> <td>B2</td> <td>OUT0</td> </tr> <tr> <td>A6</td> <td>A3</td> <td>NC</td> <td>B3</td> <td>COM</td> </tr> <tr> <td>B6</td> <td>A4</td> <td>IN5</td> <td>B4</td> <td>IN4</td> </tr> <tr> <td>(Cable connection side)</td> <td>A5</td> <td>IN3</td> <td>B5</td> <td>IN2</td> </tr> <tr> <td></td> <td>A6</td> <td>IN1</td> <td>B6</td> <td>IN0</td> </tr> </tbody> </table>					Pin Arrangement	Pin No.	Signal Name	Pin No.	Signal Name	A1	A1	0V	B1	+24V	B1	A2	OUT1	B2	OUT0	A6	A3	NC	B3	COM	B6	A4	IN5	B4	IN4	(Cable connection side)	A5	IN3	B5	IN2		A6	IN1	B6	IN0	 <table border="1"> <thead> <tr> <th>Pin No.</th> <th>Signal name</th> <th>Pin No.</th> <th>Signal name</th> </tr> </thead> <tbody> <tr> <td>A1</td> <td>IN1</td> <td>B1</td> <td>IN0 (CT0)*1</td> </tr> <tr> <td>A2</td> <td>IN2</td> <td>B2</td> <td>IN2 (CT1)*1</td> </tr> <tr> <td>A3</td> <td>IN5</td> <td>B3</td> <td>IN4 (CT2)*1</td> </tr> <tr> <td>A4</td> <td>IN7</td> <td>B4</td> <td>IN6 (CT3)*1</td> </tr> <tr> <td>A5</td> <td>IN9</td> <td>B5</td> <td>IN8</td> </tr> <tr> <td>A6</td> <td>IN11</td> <td>B6</td> <td>IN10</td> </tr> <tr> <td>A7</td> <td>IN13</td> <td>B7</td> <td>IN12</td> </tr> <tr> <td>A8</td> <td>IN15</td> <td>B8</td> <td>IN14</td> </tr> <tr> <td>A9</td> <td>NC</td> <td>B9</td> <td>COM</td> </tr> <tr> <td>A10</td> <td>Sink: NC Source: +24 Vdc</td> <td>B10</td> <td>Sink: +24 Vdc Source: +24 Vdc</td> </tr> <tr> <td>A11</td> <td>Sink: 0 Vdc Source: NC</td> <td>B11</td> <td>Sink: 0 Vdc Source: 0 Vdc</td> </tr> <tr> <td>A12</td> <td>OUT1 (PLS1, PWM1)*2</td> <td>B12</td> <td>OUT0 (PLS0, PWM0)*2</td> </tr> <tr> <td>A13</td> <td>OUT3 (PLS3, PWM3)*2</td> <td>B13</td> <td>OUT2 (PLS2, PWM2)*2</td> </tr> <tr> <td>A14</td> <td>OUT5</td> <td>B14</td> <td>OUT4</td> </tr> <tr> <td>A15</td> <td>OUT7</td> <td>B15</td> <td>OUT6</td> </tr> <tr> <td>A16</td> <td>OUT9</td> <td>B16</td> <td>OUT8</td> </tr> <tr> <td>A17</td> <td>OUT11</td> <td>B17</td> <td>OUT10</td> </tr> <tr> <td>A18</td> <td>OUT13</td> <td>B18</td> <td>OUT12</td> </tr> <tr> <td>A19</td> <td>OUT15</td> <td>B19</td> <td>OUT14</td> </tr> </tbody> </table>				Pin No.	Signal name	Pin No.	Signal name	A1	IN1	B1	IN0 (CT0)*1	A2	IN2	B2	IN2 (CT1)*1	A3	IN5	B3	IN4 (CT2)*1	A4	IN7	B4	IN6 (CT3)*1	A5	IN9	B5	IN8	A6	IN11	B6	IN10	A7	IN13	B7	IN12	A8	IN15	B8	IN14	A9	NC	B9	COM	A10	Sink: NC Source: +24 Vdc	B10	Sink: +24 Vdc Source: +24 Vdc	A11	Sink: 0 Vdc Source: NC	B11	Sink: 0 Vdc Source: 0 Vdc	A12	OUT1 (PLS1, PWM1)*2	B12	OUT0 (PLS0, PWM0)*2	A13	OUT3 (PLS3, PWM3)*2	B13	OUT2 (PLS2, PWM2)*2	A14	OUT5	B14	OUT4	A15	OUT7	B15	OUT6	A16	OUT9	B16	OUT8	A17	OUT11	B17	OUT10	A18	OUT13	B18	OUT12	A19	OUT15	B19	OUT14
Pin Arrangement	Pin No.	Signal Name	Pin No.	Signal Name																																																																																																																							
A1	A1	0V	B1	+24V																																																																																																																							
B1	A2	OUT1	B2	OUT0																																																																																																																							
A6	A3	NC	B3	COM																																																																																																																							
B6	A4	IN5	B4	IN4																																																																																																																							
(Cable connection side)	A5	IN3	B5	IN2																																																																																																																							
	A6	IN1	B6	IN0																																																																																																																							
Pin No.	Signal name	Pin No.	Signal name																																																																																																																								
A1	IN1	B1	IN0 (CT0)*1																																																																																																																								
A2	IN2	B2	IN2 (CT1)*1																																																																																																																								
A3	IN5	B3	IN4 (CT2)*1																																																																																																																								
A4	IN7	B4	IN6 (CT3)*1																																																																																																																								
A5	IN9	B5	IN8																																																																																																																								
A6	IN11	B6	IN10																																																																																																																								
A7	IN13	B7	IN12																																																																																																																								
A8	IN15	B8	IN14																																																																																																																								
A9	NC	B9	COM																																																																																																																								
A10	Sink: NC Source: +24 Vdc	B10	Sink: +24 Vdc Source: +24 Vdc																																																																																																																								
A11	Sink: 0 Vdc Source: NC	B11	Sink: 0 Vdc Source: 0 Vdc																																																																																																																								
A12	OUT1 (PLS1, PWM1)*2	B12	OUT0 (PLS0, PWM0)*2																																																																																																																								
A13	OUT3 (PLS3, PWM3)*2	B13	OUT2 (PLS2, PWM2)*2																																																																																																																								
A14	OUT5	B14	OUT4																																																																																																																								
A15	OUT7	B15	OUT6																																																																																																																								
A16	OUT9	B16	OUT8																																																																																																																								
A17	OUT11	B17	OUT10																																																																																																																								
A18	OUT13	B18	OUT12																																																																																																																								
A19	OUT15	B19	OUT14																																																																																																																								
<p>*1 Signal names in parentheses () indicate the counter input used. *2 Signal names in parentheses () indicate the pulse output or PWM output used.</p>																																																																																																																											

2-1-1. DIO Interface Comparison

Digital Input Specifications

		GP-3300	STC-6300TA
Input Terminal		IN0...IN5	IN0...IN15
Rated Voltage		DC24V	
Maximum Allowable Voltage		DC28.8V	
Input Type		Sink/Source Input	
Rated Current		5.7mA (DC24V)	2.25mA
Input Resistance		4.2kΩ	10.7kΩ
Input Points		6	16
Common Lines		1	
Common Design		6 points/1 common line	16 points/1 common line
Operation Range	ON voltage	DC15V or more	DC15-28.8V
	OFF voltage	DC5V or less	
	ON current	N/A	2.25 mA
	OFF current	N/A	1.0 mA or less
Filtering	Normal input	N/A	0.5 ms x N (N is 0 to 40)
	High-speed counter (IN0, IN2, IN4, IN6)	N/A	None, 4 μs or 40 μs
Input Delay Time	OFF to ON	1.5ms or less	0.5 to 20ms *1
	ON to OFF	1.5ms or less	0.5 to 20ms *1

*1 Digital filter can be set at intervals of 0.5 ms.

		GP-3300	STC-6300TA
Input Signal Display		No LED indicators	
Status Display		None	
Isolation		Photocoupler Isolation	Digital Isolations
External Connection		12-pin connector (used with Output section)	38-pin connector (used with Output section)
External Power Supply		For Signal: DC 24V	
Cable length	Normal input	N/A	Maximum 50 m (164 ft)
	High-speed counter/Pulse catch input (IN0, IN2, IN4, IN6)	N/A	Maximum 10 m (33 ft)

2-1-1. DIO Interface Comparison

Digital Output Specifications

		GP-3300	STC-6300TA	
Output Terminal		OUT0, OUT1	OUT0 ~ OUT3	OUT4 ~ OUT15
Rated Voltage		DC24V		
Rated Voltage Range		DC20.4V to DC28.8V		
Output Type		-D81K: Sink -D81C: Source	PFXSTC6300TADDKE: Sink PFXSTC6300TADDCE: Source	
Maximum Load Current		0.2A /1-point, 0.4A /1 common	0.3 A/1-point, 3.2 A/1 common	
Minimum Load Current		N/A	1mA	1mA (Pulse/PWM output unavailable)
Output Voltage Drop		DC 1.5V or less		
Output Delay Time	OFF to ON	1ms or less	5 μs or less (with output at DC24V, 200mA)	50 μs or less (with output at DC24V, 200mA)
	ON to OFF	1ms or less	5 μs or less (with output at DC24V, 200mA)	50 μs or less (with output at DC24V, 200mA)
Voltage Leakage (when OFF)		0.1mA or less		
Clamp Voltage		39V ± 1V	N/A	
Type of Output		Transistor Output		
Common Lines		1	2	
Common Design		2 points/1 common line	8 points/1 common line x 2	
External Connection		12-pin connector (also used for Input)	38-pin connector (also used for Input)	
Output Protection Type		Output is unprotected		

		GP-3300	STC-6300TA
Internal Fuse		1.5A, 125V DIP fuse (not replaceable)	Don't have fuse inside (Chip have over current protection function)
Surge Control Circuit		Zener diode	TVS (Transient Voltage Suppressors)
Output Points		2	16
Output Signal Display		No LED indicators	
Status Display		None	
Isolation Method		Photocoupler isolation	Digital Isolations
External Power Supply		For Signal: DC24V	
Cable Length	Normal output	N/A	Maximum 150 m (492 ft)
	Pulse/PWM output	N/A	Maximum 5 m (16 ft)

2-2. Standards Compatibility

Certification	GP-3300T/S/L (DIO)	STC-6300TA
CE (EN61000-6-4, EN61000-6-2, EN61131-2)	✓	✓
UKCA	-	✓
UL/cUL	✓ (UL508) (CSA C22.2 No.142)	✓ (UL61010-2-201) (CSA C22.2 No.61010-2-201)
UL/cUL Class 1, Div. 2	✓ (ANSI/ISA12.12.01) (CSA C22.2 No213)	✓ (UL121201) (CSA C22.2 No213)
ATEX (Zones 2/22, equipment category 3 Gas Dust)	✓	✓
IECEx (Zones 2/22, equipment category 3 Gas Dust)	-	✓
UKEX	-	Planned *1
KCs	-	Planned *1
NEPSI → CCC-Ex	-	Planned *1
RCM (C-Tick)	-	✓
EAC (GOST-R)	✓	✓
RoHS for EU	✓	✓
RoHS for China	✓	✓
REACH	✓	✓
CCC *apply for CCC exemption	-	-
KC	✓	✓
Marine	-	DNV, ABS, BV, NK, CCS, KR: Planned *1
WEEE	✓	✓

*1: Please contact our Customer Service for the latest information.

2-3. Interface Compatibility

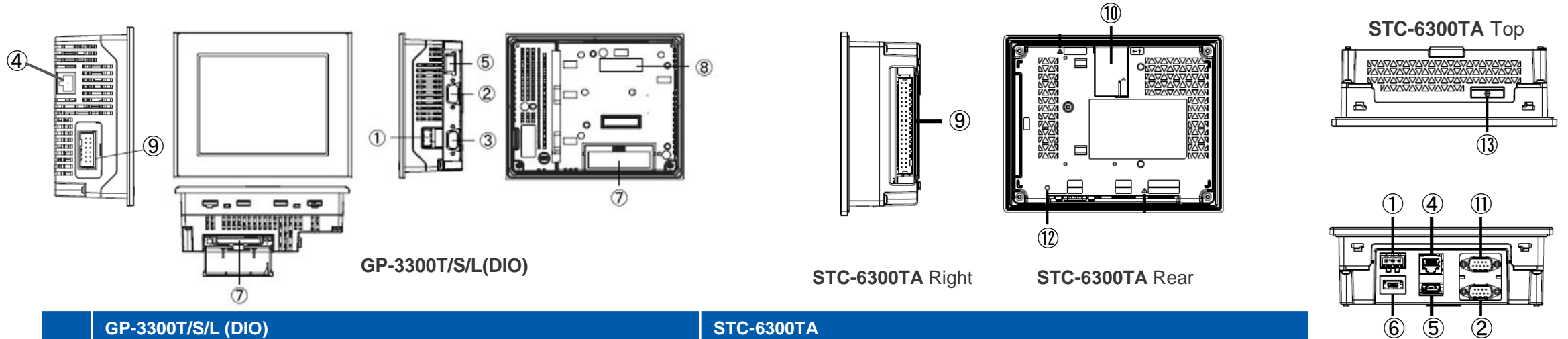

	GP-3300T/S/L (DIO)	STC-6300TA
①	Power Connector (DC)	Power Connector (DC)
②	Serial Interface (COM1)	Serial Interface (COM1)
③	Serial Interface (COM2)	-
④	Ethernet Interface	Ethernet Interface
⑤	USB (Type A) Interface	USB (Type A) Interface
⑥	-	USB (micro-B) Interface
⑦	CF Card Interface	-
⑧	Expansion Unit Interface (for expansion units)	-
⑨	DIO Interface	DIO Interface
⑩	-	Expansion Module Interface (for TM3 / EX module connection)
⑪	-	CANopen Interface *1
⑫	-	CANopen LED *1
⑬	-	Battery Slot

*1: CANopen interface and CANopen LED will be supported. Please contact our Customer Service for the latest information.

NOTE: Please be careful when replacing, as the wiring will change significantly. Please check [STC6000 Series Hardware Manual](#) for details such as interface specifications and pin assignments

2-4. Installation Method Compatibility

Panel cut dimensions and installation method are the same between GP-3300T/S/L and STC-6300TA.

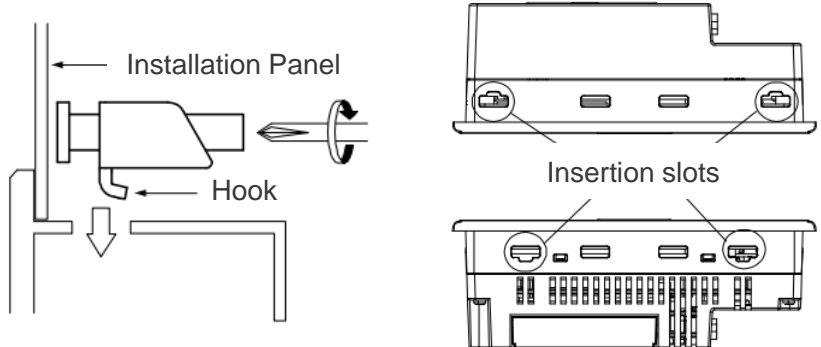
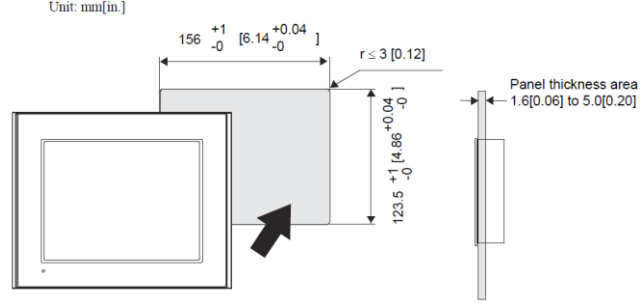
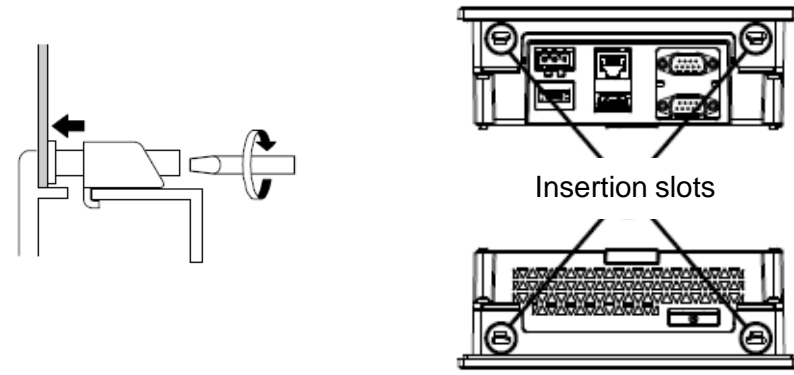
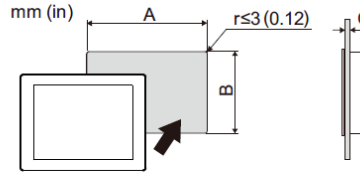
GP-3300T/S/L	STC-6300TA									
<p>The product can be installed easily by using a screwdriver. The necessary torque is 5 N•m.</p>  <p>Installation Panel Hook Insertion slots</p> <p>■ Panel Cut Dimensions</p> <p>Unit: mm[in.]</p> <p>A: 156 mm (+1/-0 mm) B: 123.5 mm (+1/-0 mm) C: 1.6~5.0 mm</p>  <p>Panel thickness area 1.6[0.06] to 5.0[0.20]</p>	<p>The product can be installed easily by using a screwdriver. The necessary torque is 5 N•m.</p>  <p>Insertion slots</p> <p>■ Panel Cut Dimensions</p> <p>mm (in)</p> <p>A: 156 mm (+1/-0 mm) B: 123.5 mm (+1/-0 mm) C: 1.6~5.0 mm</p>  <table border="1" data-bbox="1554 1128 2165 1242"> <thead> <tr> <th colspan="3">Model name</th> </tr> <tr> <th>A</th> <th>B</th> <th>C</th> </tr> </thead> <tbody> <tr> <td>156 mm (+1/-0 mm) (6.14 in [+0.04/-0 in])</td> <td>123.5 mm (+1/-0 mm) (4.86 in [+0.04/-0 in])</td> <td>1.6...5 mm (0.06...0.2 in)</td> </tr> </tbody> </table>	Model name			A	B	C	156 mm (+1/-0 mm) (6.14 in [+0.04/-0 in])	123.5 mm (+1/-0 mm) (4.86 in [+0.04/-0 in])	1.6...5 mm (0.06...0.2 in)
Model name										
A	B	C								
156 mm (+1/-0 mm) (6.14 in [+0.04/-0 in])	123.5 mm (+1/-0 mm) (4.86 in [+0.04/-0 in])	1.6...5 mm (0.06...0.2 in)								

NOTE: Installation fastener of GP-3300 (P/N: CA3-ATFALL-01) cannot be used for STC-6300TA. For STC-6300TA, please use the fastener of STC6000 Series (P/N: PFXZC3AT1). Please check [STC6000 Hardware Manual](#) for installation requirements and procedure.

2-5. Option compatibility – Serial Interface

Product Name	GP-3300T/S/L	STC-6300TA	Description	Compatibility
RS-232C Cable (5m)	CA3-CBL232/5M-01	CA3-CBL232/5M-01	Cable for RS-232C connection between various hosts and this product	✓
RS-422 Cable (5m)	CA3-CBL422/5M-01	CA3-CBL422/5M-01	Cable for RS-422 connection between various hosts and this product (Socket Type)	✓
RS-422 Cable (5m)	CA3-CBL422-01	CA3-CBL422-01	Cable for RS-422 connection between various hosts and this product (Plug Type)	✓
Mitsubishi PLC A-Series Connection Cable (5m)	CA3-CBLA-01	CA3-CBLA-01	Cable for directly connecting an A Series CPU	✓
Mitsubishi PLC Q-Series Connection Cable (5m)	CA3-CBLQ-01	CA3-CBLQ-01	Cable for directly connecting a Q Series CPU	✓
Mitsubishi PLC Q-Series Link Cable (5m)	CA3-CBLLNKM-01	CA3-CBLLNKM-01	Cable for directly connecting a Q Series Link Unit	✓
Mitsubishi PLC FX-Series Connection Cable	CA3-CBLFX/1M-01 (1m) CA3-CBLFX/5M-01 (5m)	CA3-CBLFX/1M-01 (1m) CA3-CBLFX/5M-01 (5m)	Cable for directly connecting an FX Series CPU	✓
Omron PLC SYSMAC Link Cable (5m)	CA3-CBLSYS-01	CA3-CBLSYS-01	Cable for directly connecting a SYSMAC Link Unit	✓
Siemens TTY Converter Cable (5m)	CA6-CBLTTY/5M-01	CA6-CBLTTY/5M-01	Cable for connecting a PLC S5 series to this product	✓
MPI Cable (3.5m)	ST03-A2B-MPI21-PFE GP3000-MPI21-PFE CA3-MPI-PG1-PFE CA3-MPI-PGN-PFE	ST03-A2B-MPI21-PFE	Connects a host controller to this product for MPI communication.	✓
Multi-Link Cable (5m)	CA3-CBLMLT-01 * End of sale	CA3-CBLMLT-01 * End of sale	Connects a host controller to this product for multi-link (n:1) communication.	✓
	-	PFXZCBCBML1		NEW

2-5. Option compatibility – Serial Interface

Product Name	GP-3300T/S/L	STC-6300TA	Description	Compatibility
RS-232C 9-pin/25-pin Conversion Cable (20cm)	CA3-CBLCBT232-01	CA3-CBLCBT232-01	Cable for converting a D-Sub 9-pin plug to a D-Sub 25-pin socket	✓
RS-422C 9-pin/25-pin Conversion Cable (20cm)	CA3-CBLCBT422-01 *End of sale	CA3-CBLCBT422-01 *End of sale	Cable for converting a D-Sub 9-pin plug to a D-Sub 25-pin socket	✓
	-	PFXZCBCBCVR41		NEW
2 Port Adapter Cable (5m)	CA3-MDCB11 *End of sale	CA3-MDCB11 *End of sale	Connects Mitsubishi PLC to this product using 2 port adapter II (RS-422).	✓
	-	PFXZCBCBMD1		NEW
Mitsubishi PLC A, QnA, FX Series 2 Port Adapter II	GP070-MD11 *End of sale	GP070-MD11 *End of sale	Allows simultaneous use of this product and a Mitsubishi PLC A, QnA, FX Series peripheral device.	✓
COM Port Conversion Adapter	CA3-ADPCOM-01 *End of sale	CA3-ADPCOM-01 *End of sale	Connects optional RS-422 communication items to serial interface.	✓
	-	PFXZC3ADCM1		NEW
RS-422 Terminal Block Conversion Adapter	-	PFXZCBADTM1	Connects output from a serial interface (D-sub 9 pin plug) directly to an RS-422 terminal block.	NEW
Terminal Block Conversion Adapter	CA3-ADPTRM-01	CA3-ADPTRM-01	Connects output from a serial interface (D-sub 9 pin socket) directly to an RS-422 terminal block.	✓
RS-232C Isolation Unit *1	CA3-ISO232-01	CA3-ISO232-01	Connects a host controller to this product and provides isolation (RS-232C and RS-422 are switchable).	✓
RS-485 Isolation Unit	CA3-ISO485-01	-	Connects a host controller to this product with provides isolation. (RS-422 and RS-485 are switchable.)	-
On-line adapter	CA4-ADPONL-01	-	Terminal adapter in the case of performing RS-422/RS-485 communication at COM2 port.	-
Siemens COM Port Conversion Adapter	CA3-ADPSEI-01	-	Connects Siemens PLCs to the AGP. (for RS-485 communication)	-

***1** To use RS-232C Isolation Unit, set the pin #9 of COM port to VCC.

2-5. Option compatibility – USB Interface

Product Name	GP-3300T/S/L	STC-6300TA	Description	Compatibility
USB Transfer Cable (2m)	CA3-USBCB-01	-	Cable for transferring screen data between a PC (USB Type A) and this product (USB Type A)	- A to A screen transfer is not available.
USB Transfer Cable	-	PFXZUSCBMB2	Cable for transferring screen data from a PC (USB Type A) to this product (USB micro-B)	NEW
USB Cable (5m)	FP-US00	FP-US00	Connects a USB printer (Type B)	✓
USB Front Cable (1m)	CA5-USBEXT-01	CA5-USBEXT-01	Extension cable that attaches USB interface (Type A) to front panel	✓
USB (micro-B) Front Cable	-	PFXZCIEXMB2	Extension cable that attaches USB interface (micro-B) to front panel	NEW
USB Clamp Type A (1 port)	-	PFXZCBCLUSA1	Clamp to prevent disconnection of USB cable (USB/A, 1 port, 5 clamps/set)	NEW
USB-Serial (RS-232C) Conversion Cable (0.5m)	CA6-USB232-01	CA6-USB232-01	Cable for converting a USB interface into a serial interface (RS-232C)	✓
USB/RS-422/485 Conversion Adapter	-	PFXZCBCBCVUSR41	Adapter for connecting this product (USB Type A) to an external device (RS-422/RS-485)	NEW
EZ Tower Light tube mounting fixing plate	PFXZCETWHA1 *1	PFXZCETWHA1	USB Connection Type Monolithic EZ Tower Light tube mounting with fixing plate 3 tiers, Ø60, lighting and flashing with a buzzer	NEW
EZ Tower Light with base mounting	PFXZCETWW1 *1	PFXZCETWW1	USB Connection Type Monolithic EZ Tower with base mounting 3 tiers, Ø60, lighting and flashing with a buzzer	NEW
EZ Illuminated Switch	-	PFXZCCEUSG1	A unit of 5 illuminated switches with multiple color LED easily connected with this product unit via USB	NEW
EZ LAN Adapter	-	PFXZCGEUUE1	An adapter to expand an Ethernet port to HMI	NEW

*1: This product cannot use for GP-3300 Series that is before Rev.3.

2-5. Option compatibility – Other options

Product Name	GP-3300T/S/L	STC-6300TA	Description	Compatibility
CF Card (128MB)	CA3-CFCALL/128MB-01	-	CF Card to insert into the CF card slot of this product.	-
CF Card (256MB)	CA3-CFCALL/256MB-01	-		-
CF Card (512MB)	CA3-CFCALL/512MB-01	-		-
CF Card (1GB)	CA3-CFCALL/1GB-01	-		-
CF Card (2GB)	CA3-CFCALL/2GB-01	-		-
CF Card Adapter	GP077-CFAD10	-	Used for read/write of CF Card data via a PC's PCMCIA slot.	-
Screen Protection Sheet	CA3-DFS6-01	-	Disposable, dirt-resistant sheet (5 sheets/set).	NEW Use the option for STC6000 series.
	-	PFXZCBDS61		
UV Protection Sheet	-	PFXZCFUV61	Sheet to protect the display from ultraviolet light, for 5.7-inch screen (1 sheet).	NEW
Protective Cover	CA4-DCMDL-01	-	The installation of the cover is to protect Display from leaking liquid and raise resistant performance against chemical substance (5 sheets)	-
Environment Cover		PFXZCBOP61	Disposable, environmental resistant cover for 5.7-inch screen (1 sheet).	NEW

2-5. Option compatibility – Expansion Unit

Product Name	GP-3300T/S/L	STC-6300TA	Description	Compatibility
PROFIBUS-DP Slave Unit	PFXZC5EUPFS (CA5-PFSALL/EX-01)	-	Expansion Unit for connecting GP to PROFIBUS network or communicating with a PROFIBUS-DP master.	-
Device Net Slave Unit	PFXZC6EUDNS1 (CA6-DNSALL/EX-01)	-	Expansion Unit for connecting GP to DeviceNet network or communicating with a DeviceNet master.	-
CC-Link Unit	PFXZC7EUCL1 (CA7-CCLALL/EX-01)	-	Expansion Unit for connecting GP to CC-Link network or communicating with a CC-Link master.	-
CANopen Slave Unit	PFXZC9EUCA1 (CA9-CANALL/EX-01)	-	Expansion unit, for communicating with the CANopen master and connecting the GP to a CANopen network.	-

*These expansion units for GP-3300T/S/L cannot be used for STC-6300TA.

2-5. Option compatibility – Maintenance options

Product Name	GP-3300T/S/L	STC-6300TA	Description	Compatibility
Installation Fastener	CA3-ATFALL-01	-	Installation fastener (4 pieces/set)	NEW Use the option for STC6000 series.
	-	PFXZC3AT1		
Installation Gasket	CA3-WPG6-01	-	Provides dust and moisture resistance when this product is installed into a solid panel (1 piece).	NEW Use the option for STC6000 series.
	-	PFXZHWG31		
Connector Cover	CA3-BUSCVR-01	-	Protects this product's rear face connector	-
USB Cable Clamp (1 port)	CA5-USBATM-01	-	USB Cable clamp for 2 port products to prevent disconnection	-
DC Power Supply Connector	CA5-DCCNM-01	CA5-DCCNM-01	Connector to connect DC power supply cables	✓
Battery for Data Backup	-	PFXZGEBT1	Primary battery for memory and time data backup (1 piece)	NEW
Panel Cutout Adapter	CA4-ATM5-01	-	Panel cutout adapter for mounting GP-3300 series in cutout of GP-37W2B	-
DIO Connector	CA6-DIOCNALL-01	-	Connectors for interfacing with external I/O devices (5 pieces/set).	NEW Use the option for STC6000 series.
	-	PFXZC7CNXY321		
TM3 Module Securing Hook	-	PFXZHMSH1	TM3 module securing hook (1 piece)	NEW

2-6. Other Important Notes on Hardware

- About Serial Interface
 - The Serial Interface specifications (such as pin assignment and the shape of plug/socket) of STC-6300TA are different from GP-3300T/S/L. For the details, refer to [STC6000 Hardware Manual](#).
 - The RS-232C/422/485 device that was connected via COM1 on GP-3300T/S/L will be connected via COM1 on STC-6300TA. (The same cable connection can be used.)
 - The RS-422/485 device that was connected via COM2 on GP-3300T/S/L will be connected via COM1 on STC-6300TA. (The same cable connection can be used, but conversion cable is required.)
Before STC-6300TA is connected, be sure to change the port setting to "COM1" in "Device/PLC Settings" on GP-Pro EX. Also, please check the communication settings again with "[GP-Pro-EX Device/PLC Connection Manual](#)" just in case.
 - If you have configured GP-3300T/S/L to connect both COM1 and COM2 to connected devices, you will only be able to connect them via COM1 when replacing to STC-6300TA. In this case, change either COM1 or COM2 to other communication method.
 - By using "USB/RS-422/485 Conversion Adapter", you can use the USB interface of STC-6300TA as RS-422/485 Serial Interface. For the details, refer to "[USB/RS-422/485 Conversion Adapter Installation Guide](#)".
As the connectable devices with USB/RS-422/485 Adapter are limited, please also refer to "[USB/RS-422/485 Conversion Adapter Connection Guide](#)" to see the list of supported drivers.

2-6. Other Important Notes on Hardware

- Do not expose the hardware to direct sunlight. Recommend to use the option item “UV Protection Sheet” to protect the display from ultraviolet light.
- This product is not designed for outdoor use. UL certification obtained is for indoor use only.
- Do not turn on the hardware if condensation has occurred inside the device.
- The panel brightness may decrease when used for a long time in an environment continuously filled with inert gas. Please ventilate the control panel periodically.

3. Software Section

3-1. Replacement Procedure – Workflow

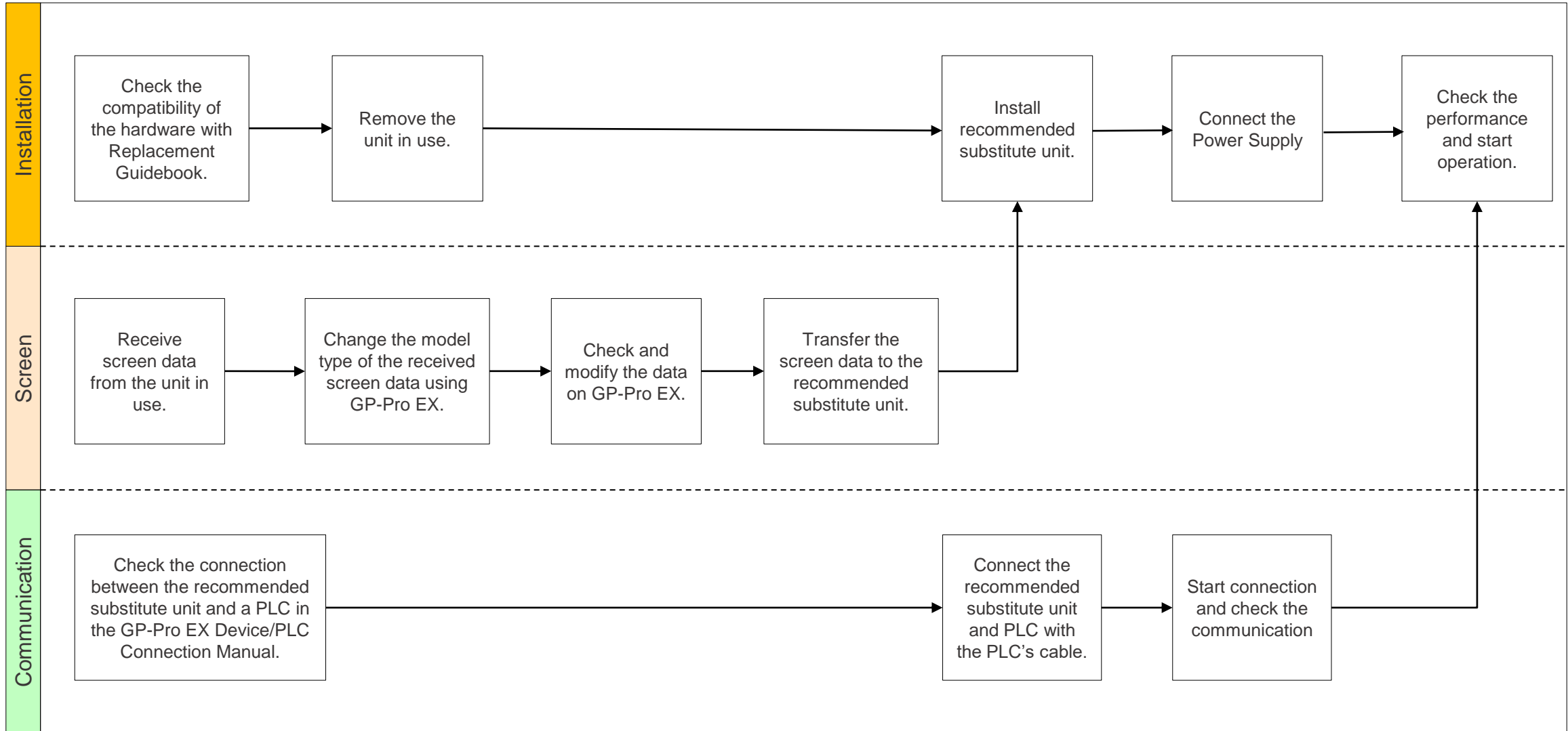

3-1. Replacement Procedure – Preparation

Requirements for receiving screen data from the unit in use *1	PC in which GP-Pro EX Transfer Tool is installed. *2
	Transfer Cable (the followings can be used) USB transfer cable: CA3-USBCB-01 (Type A - Type A) *It's also possible to send/receive a screen via CF Card, USB storage device or Ethernet.
Requirements for converting screen data of the unit in use and transferring the converted data to Recommended substitute unit	PC with GP-Pro EX installed STC-6300TA supported version: Ver. 4.09.500 or later
	Transfer Cable (the followings can be used) USB transfer cable: PFXZUSCBMB2 (Type A – Type micro-B) or commercially available USB micro-B transfer cable *It's also possible to send/receive a screen via USB storage device or Ethernet.



*1: This step is required if screen data is saved only in the HMI unit, not in any other device.
If you already have the screen data backup, please go to [“3-1. Replacement Procedure – Change model to recommended substitute unit \(GP-Pro EX\)”](#).

*2: Please use the same or later version of the software used when creating screens on the old model. If you don't know the software version, we recommend that you use the latest one. You can download the latest transfer tool from our website.

<https://www.pro-face.com/otasuke/>

3-1. Replacement Procedure – Receive Screen data from the model in use (GP-Pro EX)

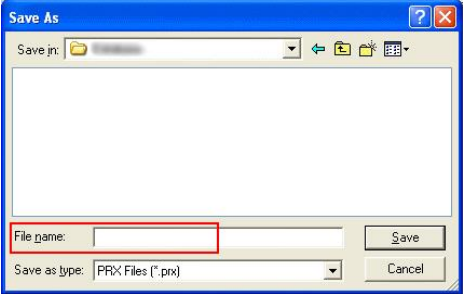
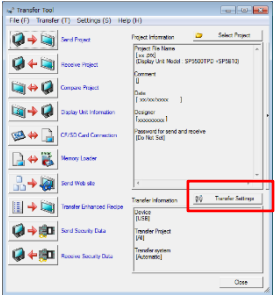
In this section, we will introduce how to receive screen data with a USB transfer cable as an example. If you have the backup of screen data, this step is not necessary. Please go to the next section.

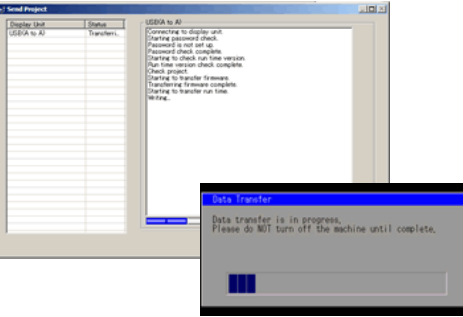
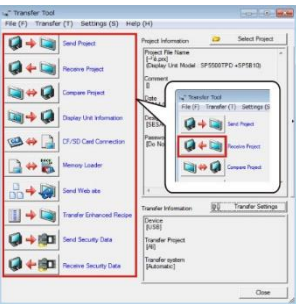
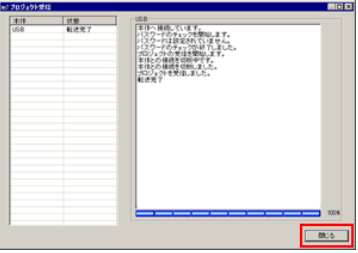
<p>1. Connect your PC and the model in use with a USB transfer cable. If the driver of the cable has not been installed on your PC yet, a dialog box will appear. Please follow the instructions.</p>		<p>5. Click [Receive Project], and the following dialog box will appear. Specify a place to save the received data in and a project file name, and then click [Save] to start transfer.</p>	
<p>2. Start the Transfer Tool of GP-Pro EX.</p>			
<p>3. Make sure that the [Device] in the “Transfer Settings Information” is set to [USB]. If not, click the [Transfer Setting] button to open the “Transfer Setting” dialog box. Select [USB] in the Communication Port Settings field and click [OK].</p>		<p>6. The following dialog box appears during transfer, and you can check the communication status. (The display unit enters the Transferring mode and communication with the device such as a PLC is terminated.)</p>	
<p>4. Start GP-Pro EX Transfer Tool and click the [Receive Project] button.</p>		<p>7. When transfer is completed, the status displayed in the dialog box will change from [Transferring] to [Complete Transfer]. Click [Close] to close the dialog box.</p>	
		<p>8. Close the Transfer Tool.</p>	

3-1. Replacement Procedure – Receive Screen data from the model in use (GP-Pro EX)

NOTES

- The “Hardware Installation” dialog box as shown on the right may appear during installing the USB driver depending on the security level of Windows®. Click [Continue Anyway] to start installing the driver. When installation is completed, click [Finish].



- When the file already exists, a window will appear asking if you want to overwrite the file.

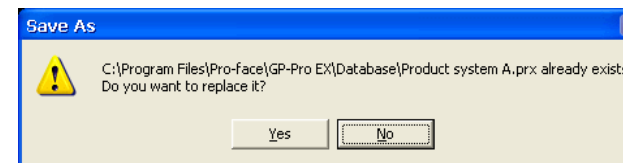

- When receiving a project file that uses SD card/USB memory data such as Recipe Function (CSV data), the following dialog box will appear during the transfer. Please specify where to save the data. Click [OK] to return to the [Receive Project] dialog box and complete the transfer.

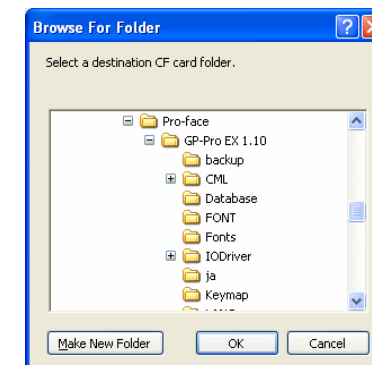

3-1. Replacement Procedure – Change model to recommended substitute unit (GP-Pro EX)

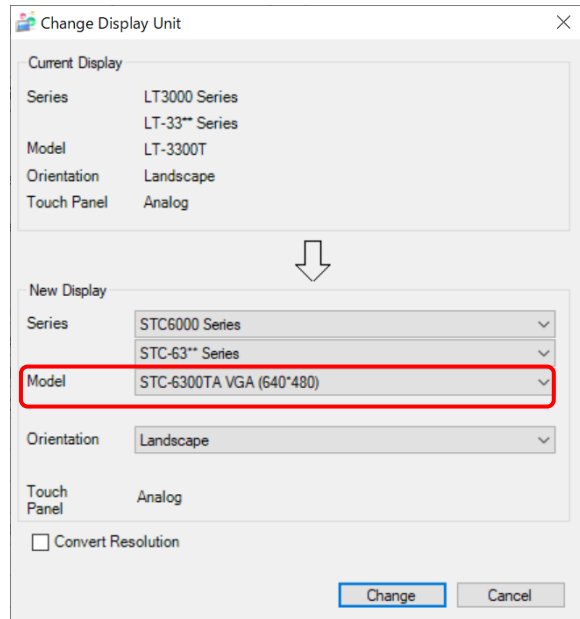

Change the Display unit from GP-3300T/S/L to STC-6300TA.

The display can be changed from the menu bar “Project” → “System Settings” → “Display” → “Change Display” in GP-Pro EX.

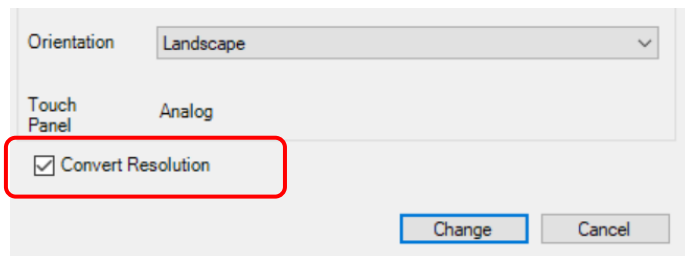

If you check on [Convert Resolution] when changing the Display Unit type (as shown below), you can adjust both size and location of the part and the text relative to the display resolution automatically. But still, you may need to adjust them manually. Please pay attention to the following points.



- A function that requires absolute coordinates. Please adjust the settings manually.
 - **Global window**
 - **Position Animation**
- Due to font size and resolution restrictions, manual changes may be required. Please resize them if needed
 - **Font:** In the case of using Standard font, the size will be smaller. You can improve by using Stroke font or Image font.
 - **Objects**
 - **Parts**
 - **Images**
 - **Alarm parts**
- Position may differ from the original project. Please check the coordinate of the window and adjust if needed.
 - **Window display**

3-1. Replacement Procedure – Transfer screen data to recommended substitute unit (GP-Pro EX)

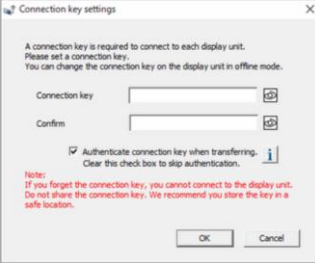
In this section, we will introduce how to transfer screen data with a USB transfer cable as an example.

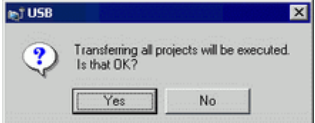
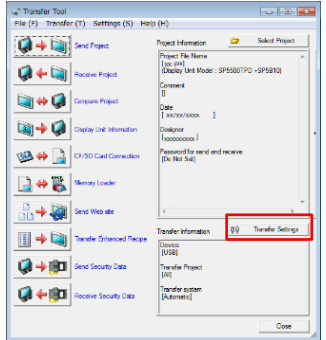
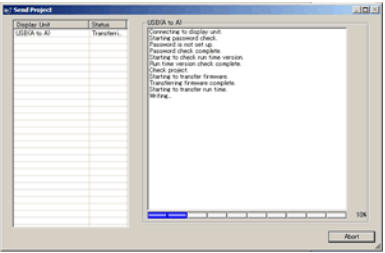
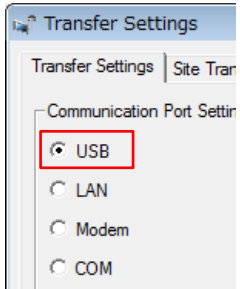
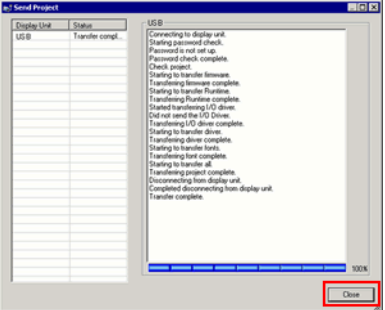
<p>1. Connect your PC and the recommended substitute unit with a USB transfer cable. If the driver of the cable has not been installed on you PC, a dialog box will appear. Please follow the instructions.</p>		<p>5. Click [Send Project]. In the dialog box that appears, set the connection key and click [OK].</p> <p>NOTE: If you forget the connection key, you will not be able to connect to the display unit. For more information about connection key, refer to GP-Pro EX reference manual (34.14.4 How the Connection Key Works).</p>	
<p>2. Turn on the power of Recommended substitute unit. The “Welcome” screen will appear on the display unit. After transferring a project file once, this screen will not appear again.</p>		<p>6. When this dialog box appears, click [Yes]. This dialog box is not displayed when the same project file is sent again.</p>	
<p>3. On the GP-Pro EX's State Toolbar, click the [Transfer Project] icon to open the Transfer Tool. To transfer a different project file, click the [Select Project] button and select a project file.</p>		<p>7. The transfer begins. The following dialog box appears during transfer, and you can check the communication status. (The display unit changes to Transferring mode and communication with the device/PLC is suspended.)</p>	
<p>4. Make sure that the [Device] in the “Transfer Settings Information” is set to [USB]. If not, click the [Transfer Setting] button to open the “Transfer Setting” dialog box. Select [USB] in the Communication Port Settings field and click [OK].</p>		<p>8. When transfer is completed, the state of the dialog box changes from [Transferring] to [Transfer Complete]. Click [Close] to close the dialog box.</p> <p>9. Close the Transfer Tool</p> <p>10. Click the [X] mark on top right of the screen or [Project] → [Exit] to close GP-Pro EX.</p>	

3-2. Software Compatibility – GP-Pro EX Supported Feature Comparison

Specification UP in STC-6300TA

NOT supported in STC-6300TA

GP-Pro EX Feature		GP-3300T/S/L (DIO)	STC-6300TA
Display	Screen Area (Application memory, unit: byte)	6M	64M
	Portrait Installation	✓	✓
	Function Expansion Memory	-	-
	Installing the USB/RS-422/485 Conversion Adapters	-	✓
	MAC Address Display	✓	✓
External Storage	CF Card	✓	-
	SD Card	-	-
	CFast Card	-	-
	USB storage	✓	✓
	FTP server	✓	✓
System Settings	Drawing in 256 colors	✓ (GP-3300T/S only)	✓
	Reverse Display	✓ (GP-3300L only)	-
	Color Blink	✓ (GP-3300T/S only)	-
	Synchronize Text Display with Text Table	✓ *1	✓
	Time Zone settings	-	-
	Detect Backlight Burnout	✓	-
	Dimmer settings	-	✓
	2-point touch / Multitouch	-	-
Display the SD/USB Removal Icon	-	✓	

*1 Only runs on display units Rev.4 or later.

3-2. Software Compatibility – GP-Pro EX Supported Feature Comparison

Specification UP in STC-6300TA

NOT supported in STC-6300TA

GP-Pro EX Feature		GP-3300T/S/L (DIO)	STC-6300TA
System Settings	Screen Capture	✓	✓
	SRAM Auto Backup	✓	✓ USB storage can be used for the models without SD/CF card slots.
	Image Font	✓ *1	✓
	Bitmap Font	✓ *1	✓
	Standard Font	✓ *1	✓
	Port Control	-	✓
Device/PLC Communication *2	Number of Devices/PLCs that can communicate simultaneously	2	2
	Specify Indirect Device	✓ *1	✓
	Import Device/PLC tags	-	✓
	Ethernet Multilink	✓ *1*3	✓
	Device Monitor	✓	✓
	Ladder Monitor	-	-
Transfer	Network Transfer	✓	✓
	Modem Transfer	✓	-
	SIO Transfer (COM Connection)	✓	-
	Memory loader feature	✓	✓
	CF/SD Card Connection	✓	-
	Connection Key	-	✓

*1 Only runs on display units Rev.4 or later.

*2 Depends on the type of connected PLC/Device.

*3 If this model is used as a master station, performance may deteriorate.

3-2. Software Compatibility – GP-Pro EX Supported Feature Comparison

Specification UP in STC-6300TA

NOT supported in STC-6300TA

GP-Pro EX Feature		GP-3300T/S/L (DIO)	STC-6300TA
Common Settings	Change Backlight Color	-	-
	Clock Update Settings	-	✓
	Start Screen Settings	-	✓
	Date format on CSV file output	✓ *1	✓
	Divide destination folders by file numbers	✓ *1	✓
	Increase Alarm Type [Extended] settings and Text Table index numbers	-	-
	Alarm Message Multiple Line Display	✓ *1	✓
	Attach Data Value to Operation Log	✓ *1	✓
	Changing passwords at run time (CSV file)	✓ *1	✓
	Changing passwords at run time (password change screen)	-	✓
	Append Date/Time to CSV File Name	-	✓
	Transfer sampling CSV file to FTP	-	✓
	Transferring sampled data to the cloud	-	✓
	Indirectly specify Sampling Frequency and Alarm Settings	✓ *1	✓
	Sampling data/Enhanced recipe data format co-exist	-	✓
	Create a recipe (CSV data) index file at runtime	✓ *1	✓
	Enhanced Recipes	-	✓
	Extended Script copy file function	✓ *1	✓
	Global Trigger	-	✓

*1 Only runs on display units Rev.4 or later.

3-2. Software Compatibility – GP-Pro EX Supported Feature Comparison

Specification UP in STC-6300TA

NOT supported in STC-6300TA

GP-Pro EX Feature		GP-3300T/S/L (DIO)	STC-6300TA
Common Settings	Movie record/play feature	-	-
	Use Image unit	-	-
	Sound Output Feature	-	-
	AUX	-	-
	Retentive Variables Function	✓	✓
Parts	Selector List	✓ *1	✓
	XY Graph (Historical Trend, Data Block Display Graph)	✓ *1	-
	Picture Display [CF Image Display] / [SD Image Display] for showing JPEG files	✓	✓ USB storage can be used for the models without SD/CF card slots.
	Indirectly specify a block of Alarm parts	✓ *1	✓
	Special Data Display [File Manager] sort function and default path	✓ *1	✓
	Special Data Display [File Manager] copy file to FTP	✓ *1	✓
	Message Display's Bulletin Message	✓ *1	✓
	Image Sensor Display	✓ *1	-
	Animation	✓ *1	✓
	Alarm History Message Flow Display	-	✓
	Alarm History / Sampling Data / Enhanced Recipe Data Refine Search / Sort Function	-	-
	Alarm Analysis Function	-	-

*1 Only runs on display units Rev.4 or later.

3-2. Software Compatibility – GP-Pro EX Supported Feature Comparison

Specification UP in STC-6300TA

NOT supported in STC-6300TA

GP-Pro EX Feature		GP-3300T/S/L (DIO)	STC-6300TA
Logic	Logic Program Operation	✓	✓
	I/O Driver	✓	✓
	Function Block	✓	✓
Network	RPA Function (end of support from Ver.4.09.400)	-	-
	GP-Viewer EX	✓	✓
	Web Server (end of support from Ver.4.09.450)	-	-
	Camera-Viewer EX	-	-
	Pro-face Remote HMI	-	✓
	E-mail	-	✓
	GP Remote Printer Server	✓	✓
	Pro-face Connect (models you can register as SiteManager)	-	✓
	Pro-Server EX	✓	✓*1
Input Equipment / Peripheral Equipment (USB Device)	USB Keyboard	✓	✓
	EZ Illuminated Switch	-	✓
	EZ Tower Light	-	✓
	EZ LAN Adapter	-	✓

*1 To use Pro-Server EX on STC-6300TA, GP-Pro EX Ver.4.09.550 or later is required.

3-2. Software Compatibility – Supported Software Version

Supported Software	GP-3300T/S/L (DIO)	STC-6300TA	Compatibility of Project Data
GP-Pro EX	✓	✓ Ver. 4.09.500 or later	✓
		https://www.pro-face.com/otasuke/files/manual/gpproex/new/refer/gpproex.htm	
Pro-Server EX	✓	✓ Ver. 1.37.300 or later *1	✓
		https://www.pro-face.com/otasuke/files/manual/soft/server_ex/v1_37/ref/SRPreface.htm	
Pro-face Remote HMI (iOS/Android)	-	✓ Ver. 1.60 or later	NEW
	-	https://www.pro-face.com/otasuke/qa/remotehmi/faq.html	
Pro-face Remote HMI Client for Win	-	✓ Ver. 1.42 or later	NEW
	-	https://www.proface.com/en/product/soft/remotehmi_client/download	
Pro-face Connect	-	✓ Ver. 9.6 or later	NEW
	-	https://www.proface.com/en/product/soft/proface_connect/download	

*1 To use Pro-Server EX on STC-6300TA, GP-Pro EX Ver.4.09.550 or later is required.

3-3. Other Important Notes on Software

- About I/O driver settings
 - STC-6300TA is equipped with DIO as standard, same as GP-3300T/S/L(DIO). Since the I/O drivers used are different, the I/O driver settings set in the GP-3300T/S/L(DIO) project will not be carried over to the STC-6300TA after conversion. If I/O assignments have been made in a GP-3300T/S/L (DIO) project, changing the model to STC-6300TA will clear all the I/O assignments, so please make the settings again.

Setting location: GP-Pro EX 【Project】→【System Settings】→【I/O Driver Settings】→【I/O Screen】

GP-3300T/S/L (DIO) Project

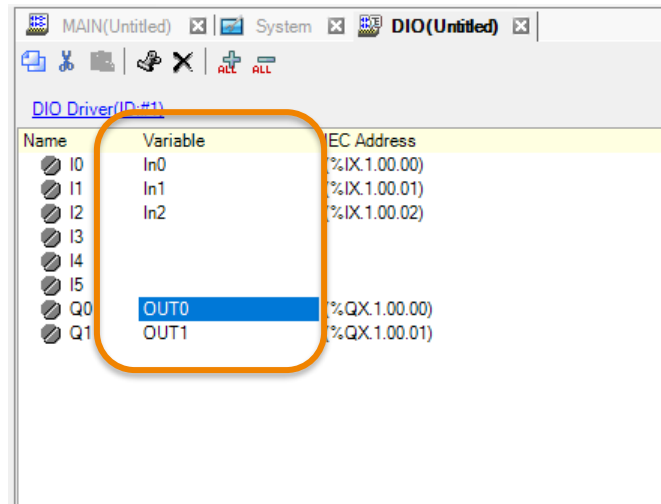

After converting to STC-6300TA

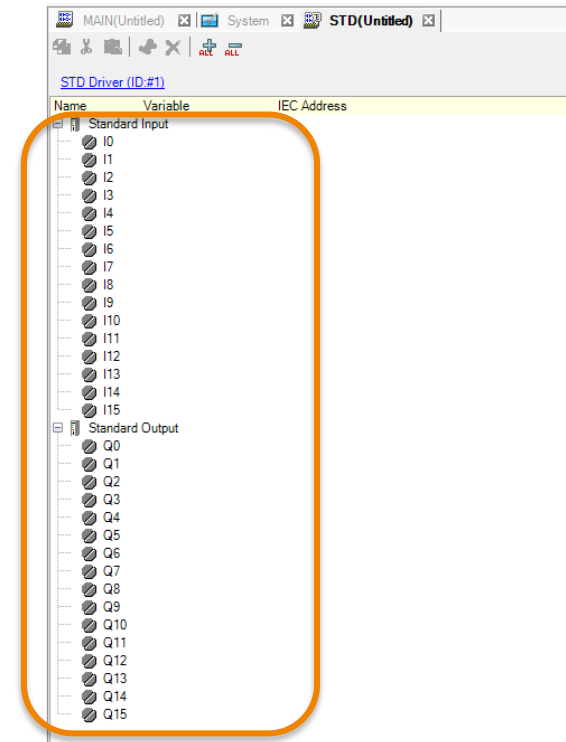
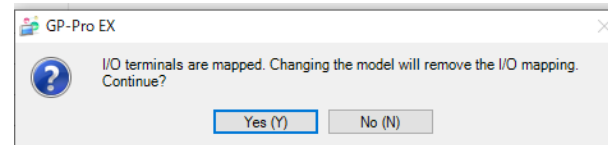

3-3. Other Important Notes on Software

- About Display colors (GP-3300L only)
 - The display color of GP-3300L is monochrome. As STC6000 Series do not support monochrome display, if you change the model to STC6000 Series, the display color will be changed to Color display. Therefore, after changing the model, be sure to check the color of the screen data with GP-Pro EX.

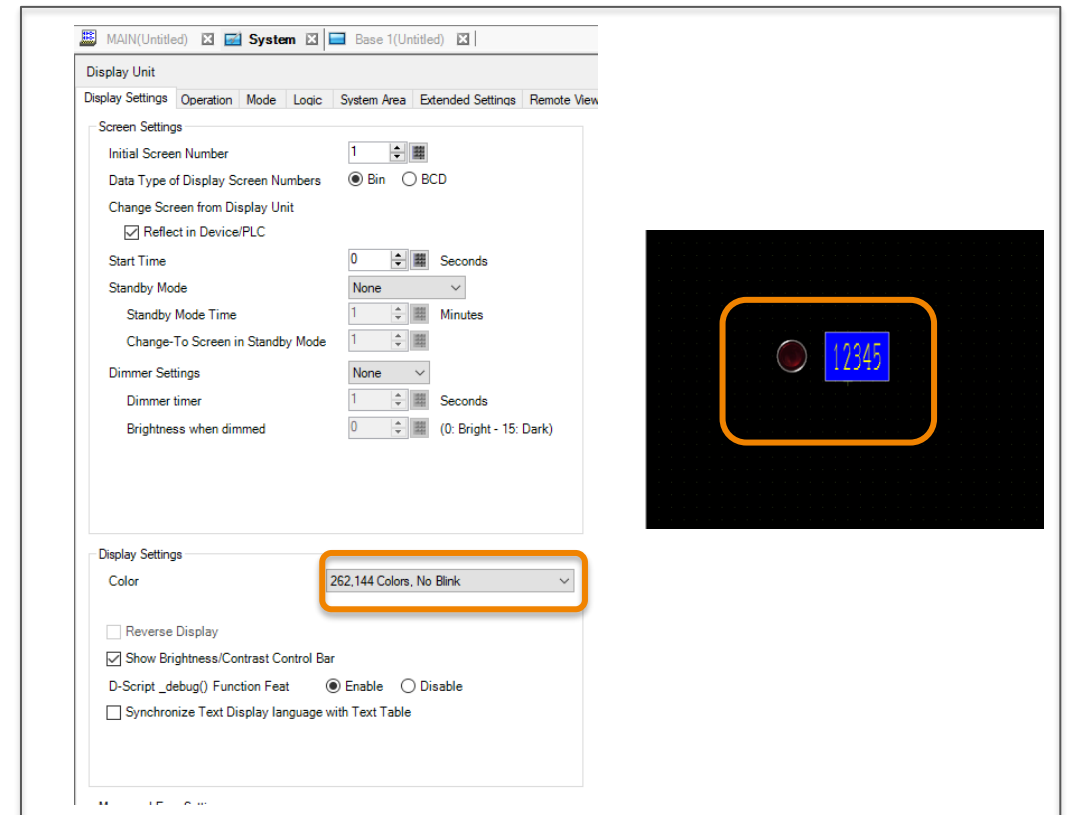
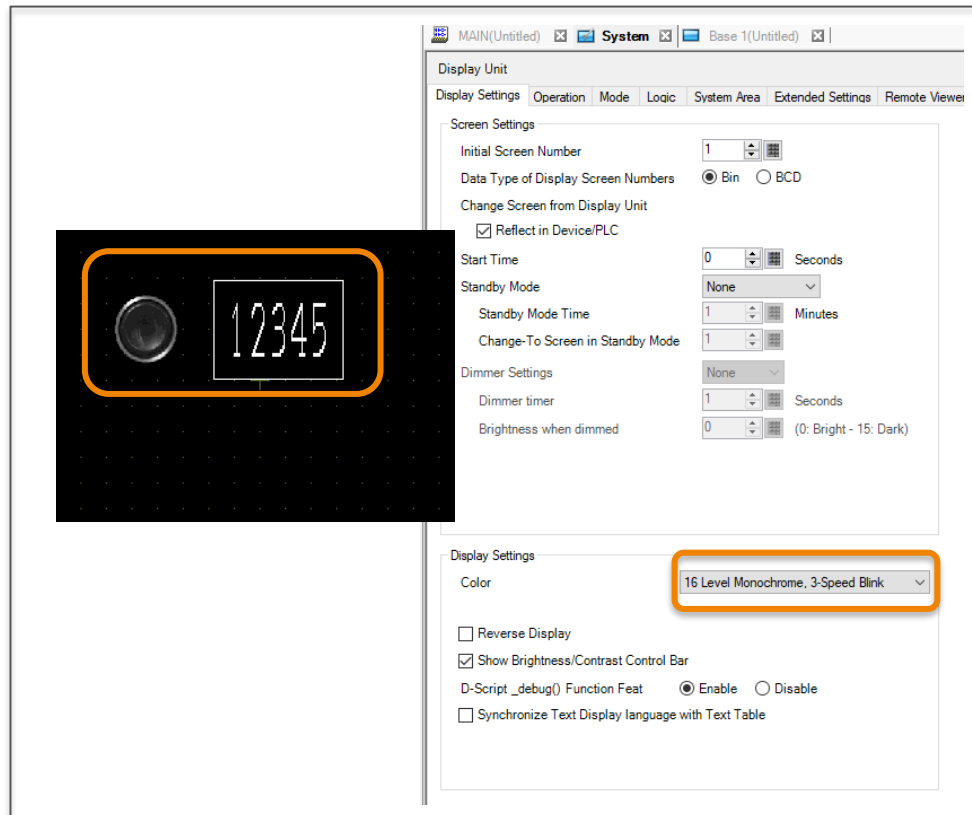

3-3. Other Important Notes on Software

- About Blink function
 - STC6000 Series do not support Blink function. Therefore, if you use the blink settings in GP3000 Series, the settings will be cancelled after changing the display to STC6000 Series in GP-Pro EX.

GP3000 Series

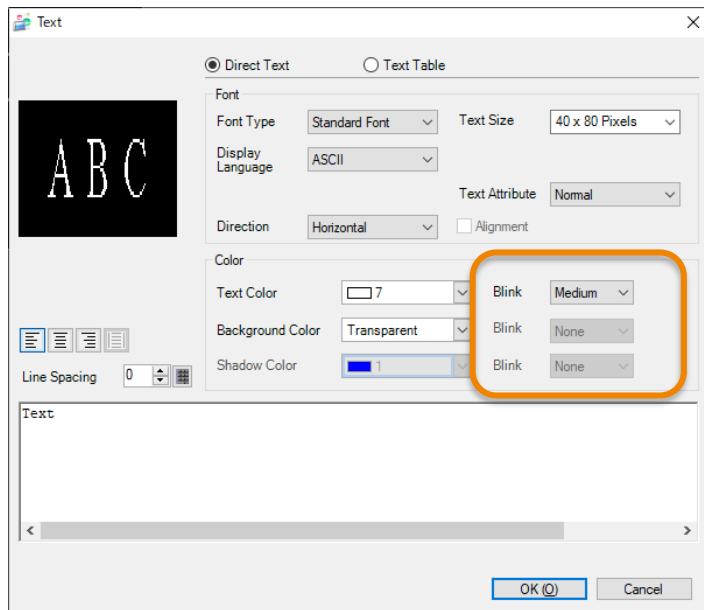

After converting the project to STC6000 Series

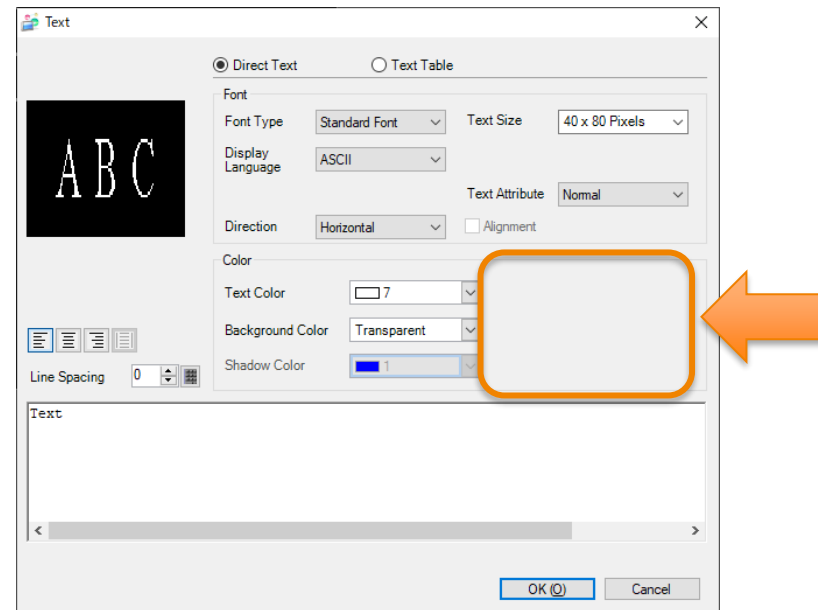

NOTE: We have a workaround to add blink functions to some of the parts/texts on STC6000 display by using the functions of the configuration software, GP-Pro EX. Refer to the following FAQ for the setting procedures.

<https://www.proface.com/en/support/faq/FAQ000268649>

3-3. Other Important Notes on Software

- Changing the setting of the external media to use
 - If a CF card is used for GP-3300 series, after the display unit type of the project file is changed to STC6000 series, “a CF card” is automatically replaced with “a SD card” for the external media setting. However, STC-6300TA does not support SD card. After conversion of the project file data, at GP-Pro EX Error Check, if the message, “The project contains features that require a SD card. However, the selected display does not support SD cards so these features will not run.” appears, change the SD card setting to the USB storage setting following the procedure below.

Level	Error Nur	Screen-Id	Summary
Warning	1506	-----	A feature that requires the SD card is enabled. However, as the current model does not support the SD card, this feature will not work.
Error			No Error

< Procedure >

- 1) Click [Project] → [Information] → [Destination Folder]
- 2) Uncheck “Enable SD Card” and check “Enable USB Storage”.

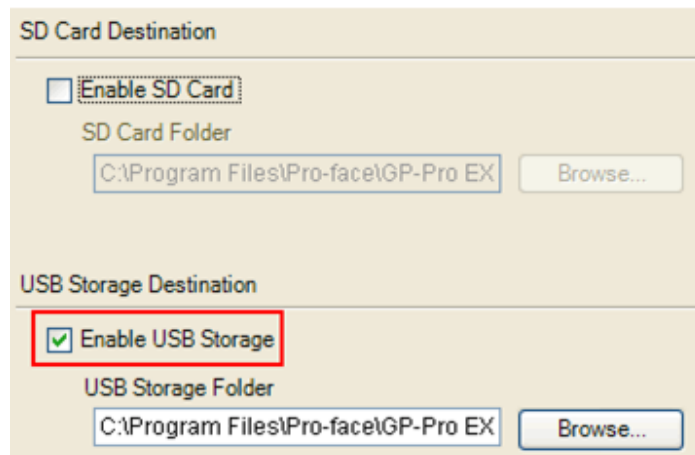

- 3) Click the [Browse] button and specify a destination folder.

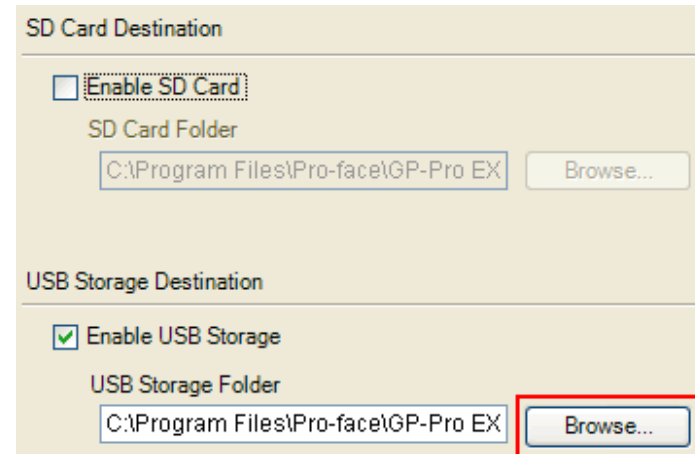

- 4) Click [OK] to confirm the setting.
- 5) Click [Project]->[Save] to save changes.
- 6) Check each function that uses the CF Card and replace the setting with [USB Storage].

