

# STC6000 Series

## Hardware Manual

STC6000-MM01-EN.02  
10/2024

# Legal Information

The information provided in this document contains general descriptions, technical characteristics and/or recommendations related to products/solutions.

This document is not intended as a substitute for a detailed study or operational and site-specific development or schematic plan. It is not to be used for determining suitability or reliability of the products/solutions for specific user applications. It is the duty of any such user to perform or have any professional expert of its choice (integrator, specifier or the like) perform the appropriate and comprehensive risk analysis, evaluation and testing of the products/solutions with respect to the relevant specific application or use thereof.

The Pro-face brand and any trademarks of Schneider Electric SE and its subsidiaries referred to in this document are the property of Schneider Electric SE or its subsidiaries. All other brands may be trademarks of their respective owner.

This document and its content are protected under applicable copyright laws and provided for informative use only. No part of this document may be reproduced or transmitted in any form or by any means (electronic, mechanical, photocopying, recording, or otherwise), for any purpose, without the prior written permission of Schneider Electric.

Schneider Electric does not grant any right or license for commercial use of the document or its content, except for a non-exclusive and personal license to consult it on an "as is" basis.

Schneider Electric reserves the right to make changes or updates with respect to or in the content of this document or the format thereof, at any time without notice.

**To the extent permitted by applicable law, no responsibility or liability is assumed by Schneider Electric and its subsidiaries for any errors or omissions in the informational content of this document, as well as any non-intended use or misuse of the content thereof.**

---

# Table of Contents

Safety Information .....	5
About the Book .....	6
Cybersecurity .....	10
Cybersecurity Guideline .....	10
Overview .....	11
Model Numbers .....	11
Package Contents .....	11
Certifications and Standards .....	13
Federal Communication Commission Radio Frequency Interference Statement - For USA .....	14
Hazardous Location Installation - For USA and Canada .....	15
Device Connectivity .....	17
System Design .....	17
Accessories .....	18
Maintenance Accessories .....	19
Parts Identification and Functions .....	20
Parts Identification .....	20
Parts Identification (STC-6300TA) .....	20
LED Indications .....	21
Status LED .....	21
Ethernet LED .....	22
Specifications .....	23
General Specifications .....	23
Electrical Specifications .....	23
Environmental Specifications .....	23
Structural Specifications .....	24
Functional Specifications .....	25
Display Specifications .....	25
Touch Panel .....	26
Memory .....	26
Clock .....	26
Interface Specifications .....	26
Specifications of Each Interface .....	26
Interface Connection .....	27
Serial Interface .....	28
DIO Interface .....	30
Dimensions .....	37
External Dimensions (STC-6300TA) .....	37
Installation and Wiring .....	39
Installation .....	39
Precautions for Building into an End-use Product .....	39
Installation Requirements .....	39
Panel Cut Dimensions .....	41
Installation Procedure .....	41
Removal Procedure .....	43
Wiring the Power Supply .....	44
DC Power Cord Preparation .....	44
How to Connect the DC Power Cord .....	45

---

Power Supply Precautions .....	46
Grounding .....	47
USB Cable Clamp .....	48
Precautions for Connecting the USB Cable .....	48
Attaching USB Clamp Type A.....	49
Removing USB Clamp Type A.....	50
Isolation Unit Installation Procedure .....	50
Wiring to the DIO Connector .....	52
DIO Interface Cable Preparation.....	52
How to Connect the DIO Cable.....	52
Installing Expansion Module .....	53
TM3 Module Installation Procedure .....	53
TM3 Module Removal Procedure .....	56
Maintenance .....	58
Regular Cleaning .....	58
Periodic Check Points .....	58
Replacing the Installation Gasket .....	59
Replacing the Battery .....	59
Replacing the Backlight.....	61
After-sales Service.....	61

# Safety Information

## Important Information

Read these instructions carefully, and look at the equipment to become familiar with the device before trying to install, operate, service, or maintain it. The following special messages may appear throughout this documentation or on the equipment to warn of potential hazards or to call attention to information that clarifies or simplifies a procedure.



The addition of this symbol to a "Danger" or "Warning" safety label indicates that an electrical hazard exists which will result in personal injury if the instructions are not followed.



This is the safety alert symbol. It is used to alert you to potential personal injury hazards. Obey all safety messages that follow this symbol to avoid possible injury or death.

### **DANGER**

**DANGER** indicates a hazardous situation which, if not avoided, **will result in** death or serious injury.

### **WARNING**

**WARNING** indicates a hazardous situation which, if not avoided, **could result in** death or serious injury.

### **CAUTION**

**CAUTION** indicates a hazardous situation which, if not avoided, **could result in** minor or moderate injury.

### **NOTICE**

**NOTICE** is used to address practices not related to physical injury.

## Please Note

Electrical equipment should be installed, operated, serviced, and maintained only by qualified personnel. No responsibility is assumed by Schneider Electric for any consequences arising out of the use of this material.

A qualified person is one who has skills and knowledge related to the construction and operation of electrical equipment and its installation, and has received safety training to recognize and avoid the hazards involved.

---

# About the Book

## Document Scope

This document describes the specifications, installation, operation, and maintenance of the STC6000 Series, which is an HMI (Human Machine Interface) device used in industrial or factory automation systems. This document is intended for users who design systems, or install and maintain components.

## Validity Note

This document is valid for STC6000 Series.

The characteristics of the products described in this document are intended to match the characteristics that are available on [www.pro-face.com](http://www.pro-face.com). As part of our corporate strategy for constant improvement, we may revise the content over time to enhance clarity and accuracy. If you see a difference between the characteristics in this document and the characteristics on [www.pro-face.com](http://www.pro-face.com), consider [www.pro-face.com](http://www.pro-face.com) to contain the latest information.

## Registered Trademarks

Microsoft® and Windows® are registered trademarks of Microsoft Corporation in the United States and/or other countries.

QR Code is a registered trademark of DENSO WAVE INCORPORATED in Japan and other countries.

Product names used in this manual may be the registered trademarks owned by the respective proprietors.

## Available Languages of this Document

This document is available in these languages:

- English (STC6000-MM01-EN)
- Japanese (STC6000-MM01-JA)
- French (STC6000-MM01-FR)
- German (STC6000-MM01-DE)
- Spanish (STC6000-MM01-ES)
- Italian (STC6000-MM01-IT)
- Chinese (STC6000-MM01-CS)
- Korean (STC6000-MM01-KO)

## Related Documents

You can download the manuals related to this product, such as the software manual, from the Pro-face download page ([www.pro-face.com/trans/en/manual/1085.html](http://www.pro-face.com/trans/en/manual/1085.html)).

# Information on Non-Inclusive or Insensitive Terminology

As a responsible, inclusive company, Schneider Electric is constantly updating its communications and products that contain non-inclusive or insensitive terminology. However, despite these efforts, our content may still contain terms that are deemed inappropriate by some customers.

## Product Related Information

If the equipment is used in a manner not specified by the manufacturer, the protection provided by the equipment may be impaired.

 <b>DANGER</b>
<b>HAZARD OF ELECTRIC SHOCK, EXPLOSION, OR ARC FLASH</b>
<ul style="list-style-type: none"><li>• Remove all power from the device before removing any covers or elements of the system, and prior to installing or removing any accessories, hardware, or cables.</li><li>• Unplug the power cable from both this product and the power supply prior to installing or removing the product.</li><li>• Always use a properly rated voltage sensing device to confirm power is off where and when indicated.</li><li>• Replace and secure all covers or elements of the system before applying power to this product.</li><li>• Use only the specified voltage when operating this product. This product is designed to use 24 Vdc. Always check whether your device is DC powered before applying power.</li><li>• When using this product in Class I, Division 2, Groups A, B, C, and D hazardous locations, install this product in an enclosure that prevents the operator from touching the back of this product without the use of tools.</li></ul>
<b>Failure to follow these instructions will result in death or serious injury.</b>

Critical alarm indicators and system functions require independent and redundant protection hardware and/or mechanical interlocks.

When you cycle power, wait at least 10 seconds after it has been turned off. If this product is restarted too quickly, it may not operate correctly.

In the event the screen cannot be properly read, for example, if the backlight is not functioning, it may be difficult or impossible to identify a function. Functions that may present a hazard if not immediately executed, such as a fuel shut-off, must be provided independently of this product. The machine's control system design must take into account the possibility of the backlight no longer functioning and the operator being unable to control the machine or making mistakes in the control of the machine.

**▲ WARNING****LOSS OF CONTROL**

- The designer of any control scheme must consider the potential failure modes of control paths and, for certain critical control functions, provide a means to achieve a safe state during and after a path failure. Examples of critical control functions are emergency stop and overtravel stop, power outage and restart.
- Separate or redundant control paths must be provided for critical control functions.
- System control paths may include communication links. Consideration must be given to the implications of unanticipated transmission delays or failures of the link.
- Observe all accident prevention regulations and local safety guidelines.
- Each implementation of this product must be individually and thoroughly tested for proper operation before being placed into service.
- The machine control system design must take into account the possibility of the backlight no longer functioning and the operator being unable to control the machine, or making errors in the control of the machine.

**Failure to follow these instructions can result in death, serious injury, or equipment damage.**

For additional information, refer to NEMA ICS 1.1 (latest edition), "Safety Guidelines for the Application, Installation, and Maintenance of Solid State Control" and to NEMA ICS 7.1 (latest edition), "Safety Standards for Construction and Guide for Selection, Installation and Operation of Adjustable-Speed Drive Systems" or their equivalent governing your particular location.

**▲ WARNING****UNINTENDED EQUIPMENT OPERATION**

- The application of this product requires expertise in the design and programming of control systems. Only persons with such expertise should be allowed to program, install, alter, and apply this product.
- Follow all applicable safety standard, local regulations and directives.

**Failure to follow these instructions can result in death, serious injury, or equipment damage.**

**▲ WARNING****UNINTENDED EQUIPMENT OPERATION**

- Do not use this product as the only means of control for critical system functions such as motor start/stop or power control.
- Do not use this equipment as the only notification device for critical alarms, such as device overheating or overcurrent.
- Use only the software provided with this product. If you use other software, please confirm the operation and safety before use.

**Failure to follow these instructions can result in death, serious injury, or equipment damage.**

The following characteristics are specific to the LCD panel and are considered normal behavior:

- LCD screen may show unevenness in the brightness of certain images or may appear different when seen from outside the specified viewing angle. Extended shadows, or crosstalk may also appear on the sides of screen images.
- LCD screen pixels may contain black and white colored spots and color display may seem to have changed.



- When experiencing vibrations within a certain frequency range and vibration acceleration is above what is acceptable, the LCD screen may partially turn white. Once the vibration condition ends, the whitening of the screen is resolved.
- When the same image is displayed on the screen for a long period, an afterimage may appear when the image is changed.
- The panel brightness may decrease when used for a long time in an environment continuously filled with inert gas. To prevent deterioration of panel brightness, regularly ventilate the panel. For more information, please contact customer support.  
<https://www.pro-face.com/trans/en/manual/1015.html>

## **▲ WARNING**

### **SERIOUS EYE AND SKIN INJURY**

The liquid in the LCD panel contains an irritant:

- Avoid direct skin contact with the liquid.
- Wear gloves when you handle a broken or leaking unit.
- Do not use sharp objects or tools in the vicinity of the LCD panel.
- Handle the LCD panel carefully to prevent puncture, bursting, or cracking of the panel material.
- If the panel is damaged and any liquid comes in contact with your skin, immediately rinse the area with running water for at least 15 minutes. If the liquid gets in your eyes, immediately rinse your eyes with running water for at least 15 minutes and consult a doctor.

**Failure to follow these instructions can result in death, serious injury, or equipment damage.**

## **NOTICE**

### **REDUCTION OF SERVICE LIFE OF PANEL**

Change the screen image periodically and try not to display the same image for a long period of time.

**Failure to follow these instructions can result in equipment damage.**

# Cybersecurity

## Cybersecurity Guideline

Use this product inside a secure industrial automation and control system. Total protection of components (equipment/devices), systems, organizations, and networks from cyber attack threats requires multi-layered cyber risk mitigation measures, early detection of incidents, and appropriate response and recovery plans when incidents occur. For more information about cybersecurity, refer to the Pro-face HMI/IPC Cybersecurity Guide.

[https://www.proface.com/en/download/manual/cybersecurity\\_guide](https://www.proface.com/en/download/manual/cybersecurity_guide)

### **⚠ WARNING**

#### **POTENTIAL COMPROMISE OF SYSTEM AVAILABILITY, INTEGRITY, AND CONFIDENTIALITY**

- Change default passwords at first use to help prevent unauthorized access to device settings, controls and information.
- Disable unused ports/services and default accounts, where possible, to minimize pathways for malicious attacks.
- Place networked devices behind multiple layers of cyber defenses (such as firewalls, network segmentation, and network intrusion detection and protection).
- Apply the latest updates and hotfixes to your Operating System and software.
- Use cybersecurity best practices (for example: least privilege, separation of duties) to help prevent unauthorized exposure, loss, modification of data and logs, interruption of services, or unintended operation.

**Failure to follow these instructions can result in death, serious injury, or equipment damage.**

# Overview

## What's in This Chapter

Model Numbers..... 11  
 Package Contents..... 11  
 Certifications and Standards ..... 13  
 Federal Communication Commission Radio Frequency Interference  
 Statement - For USA ..... 14  
 Hazardous Location Installation - For USA and Canada ..... 15

## Model Numbers

### Model List

Series	Model name	Model number
STC6000 Series	STC-6300TA	PFXSTC6300TADDKE
		PFXSTC6300TADDCE

**NOTE:** All model numbers may be followed by any letter or number.

## Model Number Configuration

The following describes the configuration of model numbers.

Digit position									
1	2	3	4	5	6	7	8	9	10
			(model)			(series)	(display size)	(type)	
PFX			STC			6	3: 5"	00: (Standard)	
11		12		13		14 and later			
(LCD)		(touch panel)		(power supply)		(available software and others)			
T: TFT		A: Analog		D: DC		DKE: Digital output sink type, GP-Pro EX DCE: Digital output source type, GP-Pro EX			

## Global Code

A global code is assigned to every Pro-face product as a universal model number. For more information on product models and their matching global codes, please refer to the following URL.

<https://www.pro-face.com/trans/en/manual/1003.html>

## Package Contents

Verify all items listed here are present in your package.

Please contact customer support immediately if you find anything damaged or missing.

**⚠ WARNING**

**UNINTENDED EQUIPMENT OPERATION**

Do not use damaged products or accessories.

**Failure to follow these instructions can result in death, serious injury, or equipment damage.**

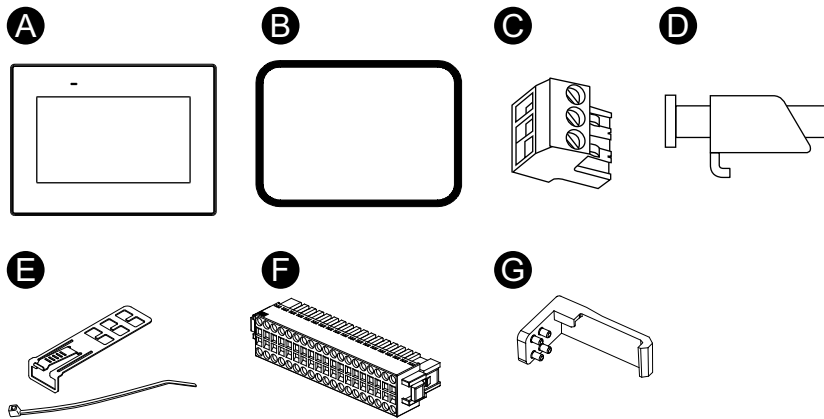

- A. STC-6300TA x 1
- B. Installation gasket (attached to this product) x 1
- C. DC power connector x 1
- D. Installation fasteners x 4
- E. USB cable clamp (Type A) x 1 set
- F. DIO connector x 1
- G. TM3 module securing hook x 1
- H. Warning/Caution Information x 1

## Product Revision and QR Code

You can identify the product version (PV) and the software version (SV) from the product label.

You can also check the contents of this manual by using the QR code on the product label. Confirm the location of the QR code below and refer to the manual.

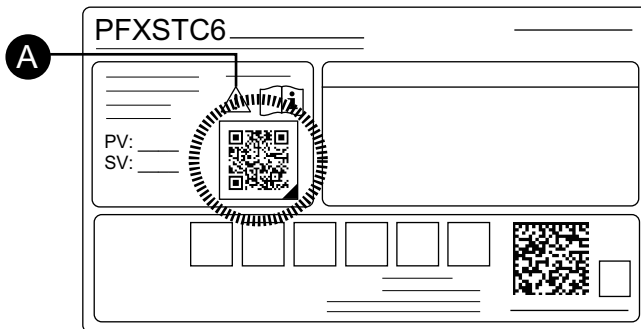

- A. This mark indicates that you can refer to this manual by using the QR code.

## Certifications and Standards

The certifications and standards listed below may include those that are not yet acquired. Please check the product marking and the following URL for the latest acquisition status.

<https://www.pro-face.com/trans/en/manual/1002.html>

### Agency Certifications

- Underwriters Laboratories Inc., UL 61010-2-201 and CSA C22.2 N°61010-2-201, for Industrial Control Equipment used in Ordinary Locations
- Underwriters Laboratories Inc., UL 121201 and CSA C22.2 N°213, for Industrial Control Equipment used in Class I, Division 2 Hazardous (Classified) Locations
- IECEx / ATEX for use in zone 2 gas /zone 22 dust
- EAC certification (Russia, Belarus, Kazakhstan)
- Merchant Navy, following IACS UR E10.

### Compliance Standards

Europe:

CE

- Directive 2014/30/EU (EMC)

ATEX

- Directive 2014/34EU

UKCA

- Regulation SI 2016 No.1091
- Regulation SI 2016 No.1107

Australia, New Zealand:

- RCM

Korea:

- KC

### Hazardous Substances

This product is designed to be compliant with the following environmental regulations, even if the product may not fall directly in the scope of the regulation:

- RoHS, Directive 2011/65/EU and 2015/863/EU
- RoHS China, Standard GB/T 26572
- REACH regulation EC 1907/2006

### End of Life (WEEE)

The product contains electronic boards. It must be disposed of in specific treatment channels. The product contains cells and/or storage batteries which must be collected and processed separately when they have run out and at the end of product life (Directive 2012/19/EU).

Refer to **Maintenance** when extracting cells and batteries from the product. These batteries do not contain a weight percentage of heavy metals over the threshold notified by European Directive 2006/66/EC.

## KC Markings

기종별	사용자안내문
A급 기기 (업무용 방송통신기자재)	이 기기는 업무용(A급) 전자파적합기기로서 판매자 또는 사용자는 이 점을 주의하시기 바라며, 가정외의 지역에서 사용하는 것을 목적으로 합니다.

## Federal Communication Commission Radio Frequency Interference Statement - For USA

### FCC Radio Interference Information

This product has been tested and found to comply with the Federal Communications Commission (FCC) limits for a Class A digital device, pursuant to Part 15 of the FCC Rules. These limits are designed to provide reasonable protection against harmful interference in a commercial, industrial or business environment. This product generates, uses, and can radiate radio frequency energy and, if not installed and used in accordance with the instructions, may cause or be subject to interference with radio communications. To minimize the possibility of electromagnetic interference in your application, observe the following two rules:

- Install and operate this product in such a manner that it does not radiate sufficient electromagnetic energy to cause interference in nearby devices.
- Install and test this product to ensure that the electromagnetic energy generated by nearby devices does not interfere with the operation of this product.

### **▲ WARNING**

#### **ELECTROMAGNETIC / RADIO INTERFERENCE, UNINTENDED EQUIPMENT OPERATION**

Check for electromagnetic and radio interference. If interference is detected, take the following actions.

- Increase the distance between this product and the interfering equipment.
- Reorient this product and the interfering equipment.
- Reroute power and communication lines to this product and the interfering equipment.
- Connect this product and the interfering equipment to different power supplies.
- Always use shielded cables when connecting this product to a peripheral device or another computer.

**Failure to follow these instructions can result in death, serious injury, or equipment damage.**

Changes or modifications not expressly approved by the party responsible for compliance could void the user's authority to operate this product.

# Hazardous Location Installation - For USA and Canada

## General

This product is suitable for use in Class I, Division 2, Groups A, B, C, and D hazardous locations or in non-hazardous locations. Before installing or using this product, confirm that the Hazardous Location certification appears on the product labeling.

**NOTE:** Some products are not yet rated as suitable for use in hazardous locations. Always use your product in conformance with the product labeling and this manual.

### **DANGER**

#### **HAZARD OF ELECTRIC SHOCK, EXPLOSION, OR ARC FLASH**

- Remove all power from the device before removing any covers or elements of the system, and prior to installing or removing any accessories, hardware, or cables.
- Unplug the power cable from both this product and the power supply prior to installing or removing the product.
- Always use a properly rated voltage sensing device to confirm power is off where and when indicated.
- Replace and secure all covers or elements of the system before applying power to this product.
- Use only the specified voltage when operating this product. This product is designed to use 24 Vdc. Always check whether your device is DC powered before applying power.

**Failure to follow these instructions will result in death or serious injury.**

### **WARNING**

#### **EXPLOSION HAZARD**

- Do not use this product in hazardous environments or locations other than Class I, Division 2, Groups A, B, C, and D.
- Substitution of any components may impair suitability for Class I, Division 2.
- Always confirm the UL 121201 or CSA C22.2 No.213 hazardous location rating of your device before installing or using it in a hazardous location.
- To apply or remove the supply power from this product installed in a Class I, Division 2 hazardous location, you must either: A) Use a switch located outside the hazardous environment, or B) Use a switch certified for Class I, Division 1 operation inside the hazardous area.
- Do not connect or disconnect equipment unless power has been switched off or the area is known to be non-hazardous. This applies to all connections including power, ground, serial, parallel, and network connections.
- Do not install any components, equipment, or accessories manufactured by us or by OEM unless these have also been qualified as suitable for use in Class I, Division 2, Groups A, B, C, and D locations.
- Always use shielded/grounded cables in hazardous locations.
- Use only non-incendive USB devices.
- Do not attempt to install, operate, modify, maintain, service, or otherwise alter this product except as permitted in this manual. Unpermitted actions may impair the suitability of this product for Class I, Division 2 operation.

**Failure to follow these instructions can result in death, serious injury, or equipment damage.**

Make sure that this product is properly rated for the location. If the intended location does not presently have a Class, Division and Group rating, then users

should consult the appropriate authorities having jurisdiction in order to determine the correct rating for that hazardous location.

## Operation and Maintenance

The systems have been designed for compliance with relevant spark ignition tests.

### **▲ WARNING**

#### **EXPLOSION HAZARD**

In addition to the other instructions in this manual, observe the following rules when installing this product in a hazardous location:

- Wire the equipment in accordance with the National Electrical Code article 501.10 (B) for Class I, Division 2 hazardous locations.
- Install this product in an enclosure suitable for the specific application.

**Failure to follow these instructions can result in death, serious injury, or equipment damage.**



# Device Connectivity

## What's in This Chapter

System Design..... 17  
 Accessories ..... 18

## System Design

This section describes the system configuration with this product and peripheral equipment.

**NOTE:** The number of interfaces, such as serial and Ethernet interfaces, varies depending on the model. Refer to *Parts Identification*.

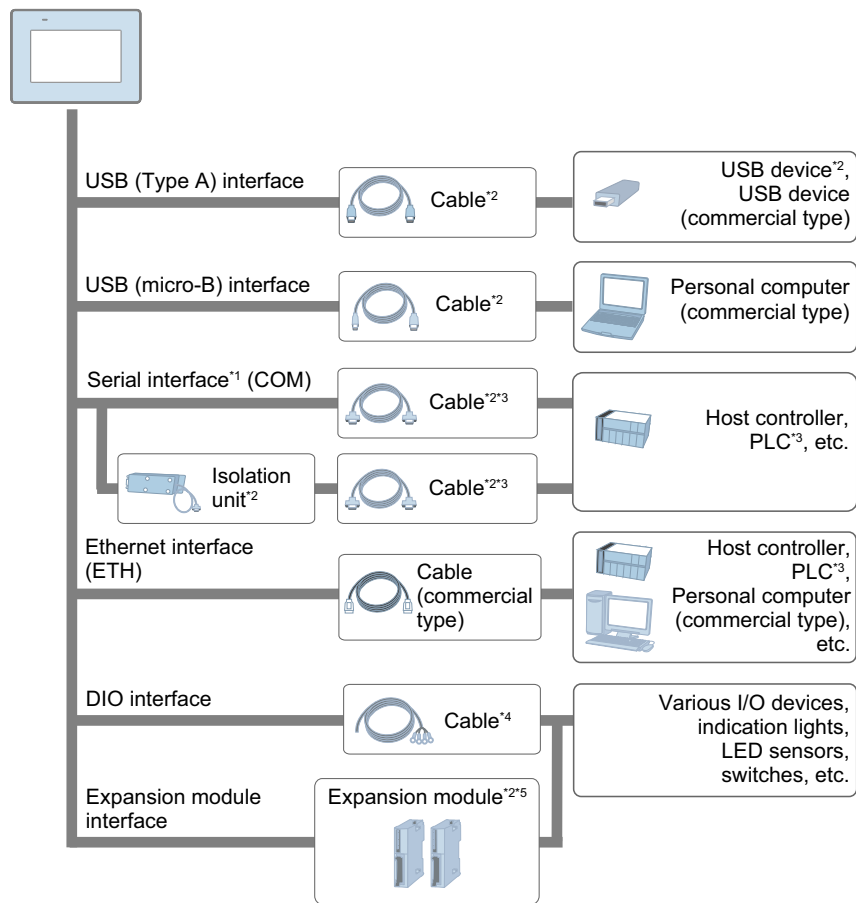

\*1 In order to use this as an isolation port, Isolation Unit is required. To use RS-232C Isolation unit, set the #9 pin of the COM port to VCC.

\*2 Refer to *Accessories*.

\*3 For information on how to connect controllers and other types of equipment, refer to the corresponding device driver manual of your screen editing software.

\*4 Prepared by the user.

\*5 Up to two TM3 modules can be connected to the rear side of the product. Optional accessories can be used to increase the number of TM3 connections. Refer to *Installing Expansion Module*.

## Accessories

Products may change or be discontinued without notice. Please check our website for the latest information.

<https://www.pro-face.com>

For host controllers and connection cables, refer to the corresponding device driver manual of your screen editing software.

Product name	Product number	Description
<b>Serial interface</b>		
RS-422 Terminal Block Conversion Adapter	PFXZCBADTM1	Connects output from a serial interface (D-sub 9 pin plug) directly to an RS-422 terminal block.
RS-232C Isolation Unit	CA3-ISO232-01	Connects a host controller to this product and provides isolation (RS-232C and RS-422 are switchable).
COM Port Conversion Adapter	CA3-ADPCOM-01	Connects optional RS-422 communication items to serial interface.
Terminal Block Conversion Adapter	CA3-ADPTRM-01	Connects output from a serial interface with an RS-422 terminal block.
<b>USB (micro-B) interface</b>		
USB Transfer Cable	PFXZUSCBMB2	Cable for transferring screen data from a PC (USB Type A) to this product (USB micro-B).
USB (micro-B) Front Cable	PFXZCIEXMB2	Extension cable that attaches USB interface to front panel.
<b>USB (Type A) interface</b>		
USB Cable (5 m)* <sup>1</sup>	FP-US00	Connects a USB printer (Type B).
USB Front Cable (1 m)	CA5-USBEXT-01	Extension cable that attaches USB interface to front panel.
USB Clamp Type A (1 port)	PFXZCBCLUSA1	Clamp to prevent disconnection of USB cable (USB Type A, 1 port, 5 clamps/set).
USB-Serial (RS-232C) Conversion Cable (0.5 m)* <sup>1</sup>	CA6-USB232-01	Cable for converting a USB interface into a serial interface (RS-232C).
USB-Serial (RS-422/485) Conversion Adapter* <sup>1</sup>	PFXZCBCBCVUSR41	Adapter for connecting this product (USB Type A) to an external device (RS-422/RS-485).
EZ Illuminated Switch* <sup>1</sup>	PFXZCCEUSG1	A unit of 5 illuminated switches with multiple color LED connected to this product via USB.
EZ Numpad* <sup>1</sup>	PFXZCCEUKB1	Numpad connected to this product via USB.
EZ Tower Light tube mounting with fixing plate* <sup>1</sup>	PFXZCETWHA1	USB Connection Type Monolithic EZ Tower Light tube mounting with fixing plate 3 tiers, Ø60, lighting and flashing with a buzzer.
EZ Tower Light with base mounting* <sup>1</sup>	PFXZCETWW1	USB Connection Type Monolithic EZ Tower with base mounting 3 tiers, Ø60, lighting and flashing with a buzzer.
EZ LAN adapter	PFXZCGEUUE1	USB adapter for extending the Ethernet port.
<b>Expansion module interface</b>		
Modicon TM3 module* <sup>1</sup>	-* <sup>2</sup>	Modicon TM3 I/O expansion module.
<b>Others</b>		

Product name	Product number	Description
Screen Protection Sheet	PFXZCBDS61	Disposable, dirt-resistant sheet for 5.7-inch screen (5 sheets/set).
UV Protection Sheet	PFXZCFUV61	Sheet to protect the display from ultraviolet light, for 5.7-inch screen (1 sheet).
Environment Cover	PFXZCBOP61	Disposable, environmental resistant cover for 5.7-inch screen (1 sheet).

\*1 Make sure your screen editing software supports the product.

\*2 The TM3 module models you can use depend on the screen editing software. For the model numbers of modules you can use, refer to the manual of your screen editing software.

## Maintenance Accessories

Product name	Product number	Description
Installation Fastener	PFXZC3AT1	Installation fastener (4 pieces/set).
Installation Gasket	PFXZHVG31	Provides dust and moisture resistance when this product is installed into a solid panel (1 piece).
DC Power Supply Connector	CA5-DCCNM-01	Connector to connect DC power supply cables.
Battery for data backup	PFXZGEBT1	Primary battery for time data backup (1 piece).
DIO Connector	PFXZC7CNXY321	Connectors for interfacing with external I/O devices (5 pieces/set).
TM3 Module Securing Hook	PFXZHMSH1	TM3 module securing hook (1 piece).

# Parts Identification and Functions

## What's in This Chapter

Parts Identification.....20  
 LED Indications.....21

## Parts Identification

### Parts Identification (STC-6300TA)

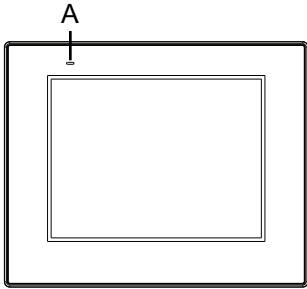
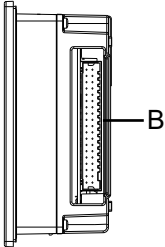
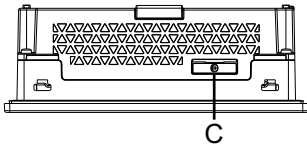
<p>Front</p>	
<p>Right</p>	
<p>Top</p>	

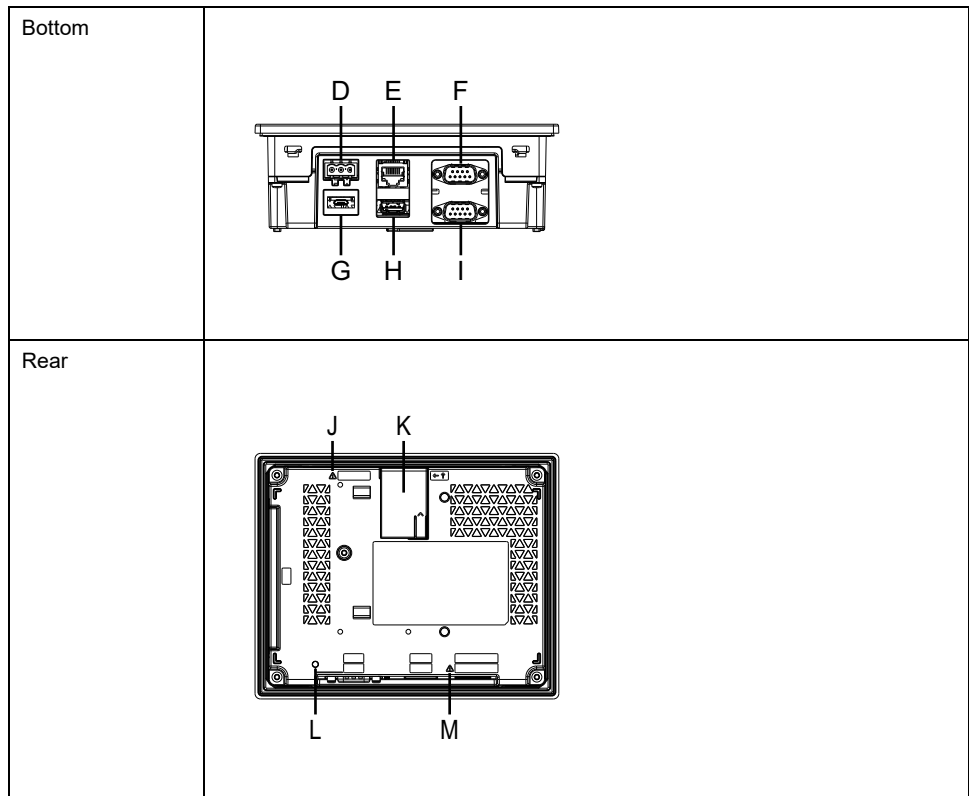

A: Status LED

B: DIO interface

C: Battery slot

D: Power plug connector

E: Ethernet interface (ETH)

F: CANopen interface (CAN)\*1

G: USB (micro-B) interface

H: USB (Type A) interface

I: Serial interface (RS-232C/422/485) (COM)

J: Safety alert symbol\*2

K: Expansion module interface

L: CANopen LED\*1

M: Safety alert symbol\*3

\*1 CANopen communication is unavailable. (CANopen interface is reserved.)

\*2 Identifies the safety messages about the battery in Replacing the Battery.

\*3 Identifies the safety messages about the power wiring in Wiring the Power Supply.

## LED Indications

### Status LED

After power is turned on, normal status indication by the LED is: red light > blinking orange > green light.

Color	Indicator	HMI operation	Logic operation
Green	ON	Offline	-
		In operation*1	RUN
	Blinking	In operation	STOP
Orange	Blinking	Software starting up	
Red	ON	Power is ON.	
	Blinking	In operation	Major error
-	OFF	Power is OFF.	

\*1 The LED remains green even if the product operation is Backlight OFF (Standby Mode).

For other LED indications, refer to the manual of your screen editing software.

## Ethernet LED

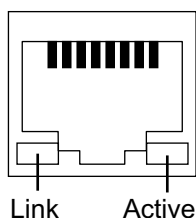

Color	Indicator	Description
Green (Link)	ON	Data transmission is available.
	OFF	No connection or error
Green (Active)	Flashing	Data transmission is occurring.
	OFF	No data transmission

# Specifications

## What's in This Chapter

General Specifications.....	23
Functional Specifications .....	25
Interface Specifications.....	26

## General Specifications

### Electrical Specifications

Rated input voltage		24 Vdc
Input voltage limits		19.2...28.8 Vdc
Voltage dip/short interruption immunity		5 ms or less (at rated input voltage)
Power consumption	Max	11.3 W
	When power is not supplied to external devices	8 W
	When screen turns off the backlight (standby mode)	5.6 W
In-rush current		30 A or less
Noise immunity		Noise voltage: 1,000 Vp-p, Pulse duration: 1 µs, Rise time: 1 ns (via noise simulator)
Dielectric strength		1,000 Vac for 1 minute (between power terminal and FG terminal)
Insulation resistance		500 Vdc, 10 MΩ or more (between power terminal and FG terminal)

## Environmental Specifications

Use and store this product in areas that conform to the specified conditions.

**NOTE:** When using any of the options for this product, check the specifications for special conditions or cautions that may apply to this product.

<b>Physical environment</b>	
Ambient air temperature	0...50 °C (32...122 °F) <sup>1</sup>
Storage temperature	-20...60 °C (-4...140 °F)
Ambient air and storage humidity	10%...90% RH (Non condensing, wet bulb temperature 39 °C [102.2 °F] or less)
Dust	0.1 mg/m <sup>3</sup> (10 <sup>-7</sup> oz/ft <sup>3</sup> ) or less (non-conductive levels)
Pollution degree	For use in Pollution Degree 2 environment
Corrosive gases	Free of corrosive gases
Atmospheric pressure (operating altitude)	800...1,114 hPa (2,000 m [6,561 ft] or lower)
<b>Mechanical environment</b>	

Vibration resistance	IEC/EN 61131-2 compliant 5...9 Hz Single amplitude 3.5 mm (0.14 in) 9...150 Hz Fixed acceleration: 9.8 m/s <sup>2</sup> X, Y, Z directions for 10 cycles (approximately 100 minutes)
Shock resistance	IEC/EN 61131-2 compliant 147 m/s <sup>2</sup> , X, Y, Z directions for 3 times
<b>Electrical environment</b>	
Electrical fast transient/burst immunity	IEC 61000-4-4 2 kV: Power port 1 kV: Signal ports
Electrostatic discharge immunity	Contact discharge method: 6 kV Air discharge method: 8 kV (IEC/EN 61000-4-2 Level 3)

\*1 For ATEX/IECEx installations, 0 to 45 °C (32 to 113 °F). Temperature class (T-Code): T4

<b>▲ CAUTION</b>
<b>INOPERATIVE EQUIPMENT</b>
<ul style="list-style-type: none"> <li>Do not operate or store the product where chemicals evaporate, or where chemicals are present in the air. Chemicals refer to the following: A) Corrosive chemicals: Acids, alkalines, liquids containing salt, B) Flammable chemicals: Organic solvents.</li> <li>Do not allow water, liquids, metal, and wiring fragments to enter the panel case.</li> </ul>
<b>Failure to follow these instructions can result in injury or equipment damage.</b>

## Structural Specifications

Grounding	Functional grounding: Grounding resistance of 100 Ω or less, 2 mm <sup>2</sup> (AWG 14) or thicker wire, or your country's applicable standard (SG and FG are connected inside the product).
Cooling method	Natural air circulation
Structure*1	IP65F, UL 50/50E, Type 1, Type 4X (indoor use only), Type 12 and Type 13 (on the front panel when properly installed in an enclosure)
External dimensions (W x H x D)	169.5 x 137 x 60 mm (6.67 x 5.39 x 2.36 in)
Panel cut dimensions (W x H) <sup>2,3</sup>	156 x 123.5 mm (6.14 x 4.86 in) Panel thickness area: 1.6...5 mm (0.06...0.2 in)
Weight	0.8 kg (1.76 lb) or less

\*1 The front face of this product, installed in a solid panel, has been tested using conditions equivalent to the standards shown in the specification. Even though this product's level of resistance is equivalent to these standards, oils that should have no effect on this product can possibly harm this product. This can occur in areas where either vaporized oils are present, or where low viscosity cutting oils are allowed to adhere to this product for long periods of time. If this product's front face protection sheet or cover glass peels off, these conditions can lead to the ingress of oil into this product and separate protection measures are suggested. Also, if non-approved oils are present, they may cause deformation or corrosion of the front panel's cover. Therefore, prior to installing this product, be sure to confirm the type of conditions that will be present in this product's operating environment.

If the installation gasket is used for a long period of time, or if this product and its gasket are removed from the panel, the original level of protection cannot be kept. To maintain the original protection level, be sure to replace the installation gasket regularly.



\*2 For dimensional tolerance, everything +1/-0 mm (+0.04/-0 in) and R in angle are below R3 (R0.12 in).

\*3 Even if the installation wall thickness is within the recommended range for the Panel Cut Dimensions, depending on the wall's material, size, and installation location of this product and other devices, the installation wall could warp. To prevent warping, the installation surface may need to be strengthened.

<b>NOTICE</b>
<p><b>EQUIPMENT DAMAGE</b></p> <ul style="list-style-type: none"> <li>• Ensure this product is not in permanent and direct contact with oils.</li> <li>• Do not press on the display of this product with excessive force or with a hard object.</li> <li>• Do not press on the touch panel with a pointed object, such as the tip of a mechanical pencil or a screwdriver.</li> <li>• Do not expose the product to direct sunlight.</li> </ul> <p><b>Failure to follow these instructions can result in equipment damage.</b></p>

<b>NOTICE</b>
<p><b>STORAGE AND OPERATION OUTSIDE OF SPECIFICATIONS</b></p> <ul style="list-style-type: none"> <li>• Store this product in areas where temperatures are within the product's specifications.</li> <li>• Do not restrict or block the product's ventilation slots.</li> </ul> <p><b>Failure to follow these instructions can result in equipment damage.</b></p>

<b>NOTICE</b>
<p><b>GASKET AGING</b></p> <ul style="list-style-type: none"> <li>• Inspect the gasket periodically as required by your operating environment.</li> <li>• Replace the gasket at least once a year, or as soon as scratches or dirt become visible.</li> </ul> <p><b>Failure to follow these instructions can result in equipment damage.</b></p>

## Functional Specifications

### Display Specifications

Display type	TFT Color LCD
Display size	5.7"
Resolution	640 x 480 pixels (VGA)
Effective display area (W x H)	115.2 x 86.4 mm (4.54 x 3.40 in)
Display colors	262,144 colors For details about display colors, refer to the manual of your screen editing software.
Backlight	White LED (Not replaceable. Please contact customer support.)
Backlight service life	50,000 hours or more (continuous operation at 25 °C [77 °F] before backlight brightness decreases to 25%)
Brightness control	16 levels (Adjusted with touch panel or software)

## Touch Panel

Touch panel type	Resistive film (analog)
Touch points	Single touch
Touch panel resolution	1,024 x 1,024
Touch panel service life	1 million times or more

The touch panel does not support two-point touch (multiple point touch). If you touch multiple points on the touch panel, it will operate as if you touched the center-point of the multiple touches.

For example, if you touch two or more points on the touch panel and at the center of the touches is a switch for a drive system, even though you did not directly touch that switch, it may function as if you did.

<b>⚠ WARNING</b>
<b>UNINTENDED EQUIPMENT OPERATION</b>
Do not touch two or more points on the touch panel.
<b>Failure to follow these instructions can result in death, serious injury, or equipment damage.</b>

## Memory

System memory*1	Flash EPROM 1 GB (operating system, project data and other data)
Backup memory	Uses a part of Flash EPROM as the backup area. (Maximum usable capacity*1: 392 KB)

\*1 How much of each memory you can use depends on your screen editing software. Please refer to the following URL.

<https://www.pro-face.com/trans/en/manual/1082.html>

## Clock

RTC accuracy	±65 seconds per month (deviation at room temperature and power is OFF).
Clock data backup	Lithium battery (primary battery, replaceable) Battery life: 5 years (approximate)

Variations in operating conditions and battery life can cause clock deviations from -380 to +90 seconds per month. If you use this product in a system where timing is critical, adjust the clock at regular intervals.

If the battery is depleted, the clock data will be lost. To replace the battery, refer to Replacing the Battery.

## Interface Specifications

### Specifications of Each Interface

Use only the SELV (Safety Extra-Low Voltage) circuit to connect the serial, USB and Ethernet interfaces.

<b>Serial interface COM1</b>	
Connector	D-Sub 9 pin (plug)
Asynchronous transmission	RS-232C/422/485
Data length	7 or 8 bits
Stop bit	1 or 2 bits
Parity	None, odd, or even
Data transmission speed	2,400...115,200 bps, 187,500 bps (MPI)
<b>USB (Type A) interface</b>	
Connector	USB 2.0 (Type A) x 1
Power supply voltage	5 Vdc ±5%
Maximum current supplied	500 mA
Maximum transmission distance	5 m (16.4 ft)
<b>USB (micro-B) interface</b>	
Connector	USB 2.0 (micro-B) x 1
Maximum transmission distance	5 m (16.4 ft)
<b>Ethernet interface</b>	
Connector	Modular jack (RJ-45) x 1
Standard	IEEE802.3i/IEEE802.3u, 10BASE-T/100BASE-TX
<b>DIO interface</b>	
Input and Output Specifications	For input and output specifications, refer to DIO Interface.

## Interface Connection

### Cable Connections

<b>▲ WARNING</b>
<p><b>EXPLOSION HAZARD</b></p> <ul style="list-style-type: none"> <li>• Always confirm the UL 121201 or CSA C22.2 No.213 hazardous location rating of your device before installing or using it in a hazardous location.</li> <li>• To apply or remove the supply power from this product installed in a Class I, Division 2 hazardous location, you must either: A) Use a switch located outside the hazardous environment, or B) Use a switch certified for Class I, Division 1 operation inside the hazardous area.</li> <li>• Do not connect or disconnect equipment unless power has been switched off or the area is known to be non-hazardous. This applies to all connections including power, ground, serial, parallel, and network connections.</li> <li>• Always use shielded/grounded cables in hazardous locations.</li> <li>• Use only non-incendive USB devices.</li> <li>• Use the USB (micro-B) interface for temporary connection only during maintenance and setup of the device.</li> <li>• Do not use the USB (micro-B) interface in hazardous locations.</li> </ul> <p><b>Failure to follow these instructions can result in death, serious injury, or equipment damage.</b></p>

Division 2 hazardous location regulations require that all cable connections be provided with adequate strain relief and positive interlock. As this product does not provide adequate strain relief for the USB connection (USB micro-B interface) on this product, use only non-incendive USB devices. Never connect or disconnect a

cable while power is applied at either end of the cable. All communication cables should include a chassis ground shield. This shield should include both copper braid and aluminum foil. The D-sub style connector housing must be a metal conductive type (for example, molded zinc) and the ground shield braid must be terminated directly to the connector housing. Do not use a shield drain wire.

The outer diameter of the cable must be suited to the inner diameter of the cable connector strain relief so that a reliable degree of strain relief is maintained. Always secure the D-sub connectors to the workstation-mating connectors via the two screws located on both sides.

## Serial Interface

### Precautions for Connecting Serial Interface

The serial interface is not isolated.

**NOTE:** For information on how to connect controllers and other types of equipment, refer to the corresponding device driver manual of your screen editing software.

You can switch the communication method between RS-232C and RS-422/RS-485 via the software.

The SG (signal ground) and FG (frame ground) terminals are connected inside the product. When the serial interface connector is D-Sub, connect the FG wire to the shell.

#### **DANGER**

##### **ELECTRIC SHOCK AND FIRE**

When using the SG terminal to connect an external device to this product:

- Verify that a ground loop is not created when you set up the system.
- Connect the SG terminal to remote equipment when the external device is not isolated.
- Connect the SG terminal to a known reliable ground connection to reduce the risk of damaging the circuit.

**Failure to follow these instructions will result in death or serious injury.**

#### **CAUTION**

##### **LOSS OF COMMUNICATION**

- Do not put excessive stress on the communication ports of all connections.
- Securely attach communication cables to the panel wall or cabinet.
- Use a D-Sub 9 pin connector that has jack screws.

**Failure to follow these instructions can result in injury or equipment damage.**

**NOTE:** Use within the rated current.

### Serial Interface Connector RS-232C

D-Sub 9 pin plug connector

Product side:

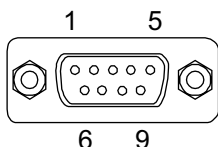

Pin No.	RS-232C		
	Signal name	Direction	Meaning
1	CD	Input	Carrier detect
2	RD (RXD)	Input	Receive data
3	SD (TXD)	Output	Send data
4	ER (DTR)	Output	Data terminal ready
5	SG	–	Signal ground
6	DR (DSR)	Input	Data set ready
7	RS (RTS)	Output	Request to send
8	CS (CTS)	Input	Send possible
9	VCC	Output	+5 Vdc ±5% Output 0.25 A*1
Shell	FG	–	Frame ground (common with SG)

\*1 When using RS-232C pin #9, enable VCC with the software.

Recommended jack screw is #4-40 (UNC).

Recommendations:

- Cable Connector: XM3D-0921 manufactured by OMRON Corporation.
- Cable Cover: XM2S-0913 manufactured by OMRON Corporation.
- Jack Screw (#4-40 UNC): XM2Z-0073 manufactured by OMRON Corporation.

## Serial Interface Connector RS-422/485

D-Sub 9 pin plug connector

Product side:

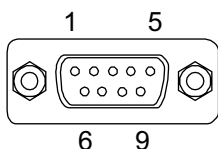

Pin No.	RS-422/RS-485		
	Signal name	Direction	Meaning
1	RDA	Input	Receive data A (+)
2	RDB	Input	Receive data B (-)
3	SDA	Output	Send data A (+)
4	ERA	Output	Data terminal ready A (+)
5	SG	–	Signal ground

Pin No.	RS-422/RS-485		
	Signal name	Direction	Meaning
6	CSB	Input	Send possible B (-)
7	SDB	Output	Send data B (-)
8	CSA	Input	Send possible A (+)
9	ERB	Output	Data terminal ready B (-)
Shell	FG	-	Frame ground (common with SG)

Recommended jack screw is #4-40 (UNC).

Recommendations:

- Cable Connector: XM3D-0921 manufactured by OMRON Corporation.
- Cable Cover: XM2S-0913 manufactured by OMRON Corporation.
- Jack Screw (#4-40 UNC): XM2Z-0073 manufactured by OMRON Corporation.

## DIO Interface

### DIO Connector

38 pin connector (Model number: CA7-DIOCN5-01)

Cable connection side:

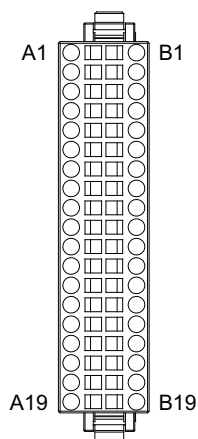

Pin No.	Signal name	Pin No.	Signal name
A1	IN1	B1	IN0 (CT0)*1
A2	IN3	B2	IN2 (CT1)*1
A3	IN5	B3	IN4 (CT2)*1
A4	IN7	B4	IN6 (CT3)*1
A5	IN9	B5	IN8
A6	IN11	B6	IN10
A7	IN13	B7	IN12
A8	IN15	B8	IN14
A9	NC	B9	COM
A10	Sink: NC Source: +24 Vdc	B10	Sink: +24 Vdc Source: +24 Vdc

Pin No.	Signal name	Pin No.	Signal name
A11	Sink: 0 Vdc Source: NC	B11	Sink: 0 Vdc Source: 0 Vdc
A12	OUT1 (PLS1, PWM1)*2	B12	OUT0 (PLS0, PWM0)*2
A13	OUT3 (PLS3, PWM3)*2	B13	OUT2 (PLS2, PWM2)*2
A14	OUT5	B14	OUT4
A15	OUT7	B15	OUT6
A16	OUT9	B16	OUT8
A17	OUT11	B17	OUT10
A18	OUT13	B18	OUT12
A19	OUT15	B19	OUT14

\*1 Signal names in parentheses () indicate the counter input used.

\*2 Signal names in parentheses () indicate the pulse output or PWM output used.

## Digital Input Specifications

Input terminal	IN0...IN15	
Rated voltage	24 Vdc	
Maximum allowable voltage	28.8 Vdc	
Input type	Sink/Source Input	
Rated current	2.25 mA	
Input resistance	10.7 kΩ	
Input points	16	
Common lines	1	
Common design	16-point/1 common line	
Operation range	ON voltage	15...28.8 Vdc
	OFF voltage	0...5 Vdc
	ON current	2.25 mA
	OFF current	1.0 mA or less
Filtering	Normal input	0.5 ms x N (N is 0 to 40)
	High-speed counter (IN0, IN2, IN4, IN6)	None, 4 μs, or 40 μs
Input signal display	No LED indicators	
Status display	None	
Isolation	Yes	
External connection	38 pin connector (used with Output section)	
Cable length	Normal input	Maximum 50 m (164 ft)
	High-speed counter/Pulse catch input (IN0, IN2, IN4, IN6)	Maximum 10 m (33 ft)

## Input Circuit

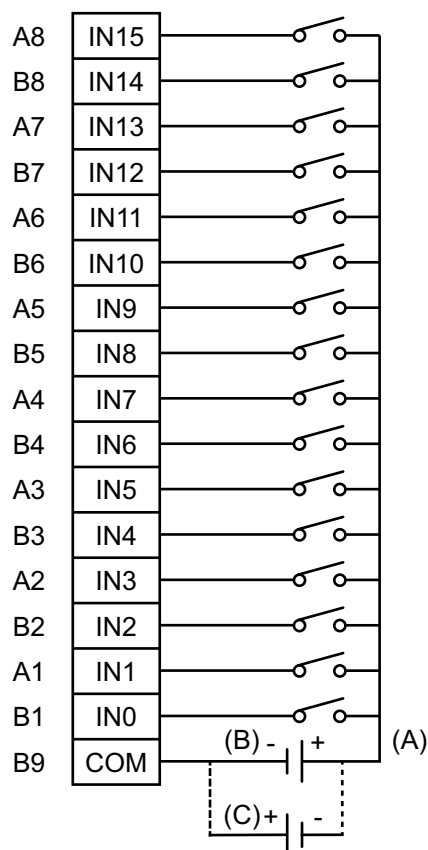

- A. 24 Vdc External power supply
- B. Sink type
- C. Source type

## Digital Output Specifications

Output terminal	OUT0...OUT3	OUT4...OUT15
Rated voltage	24 Vdc	
Rated voltage range	20.4 Vdc...28.8 Vdc	
Output type	PFXSTC6300TADDKE: Sink output PFXSTC6300TADDCE: Source output	
Maximum load current	0.3 A/point, total 3.2 A	
Minimum load current	1 mA	1 mA (Pulse/PWM output unavailable)
Output voltage drop	1.5 Vdc or less	
Output delay time	OFF to ON (With output at 24 Vdc, 200 mA)	5 μs or less
	ON to OFF (With output at 24 Vdc, 200 mA)	5 μs or less
Type of output	Transistor output	
Common lines	2	
Common design	8-point/ 1 common line x 2	
External connection	38 pin connector (used with Input section)	



Output protection type		Output is unprotected
Output points		16
Output signal display		No LED indicators
Status display		None
Isolation		Yes
External power supply		For Signal: 24 Vdc
Cable length	Normal output	Maximum 150 m (492 ft)
	Pulse/PWM output	Maximum 5 m (16 ft)

**Output Circuit: Sink type**

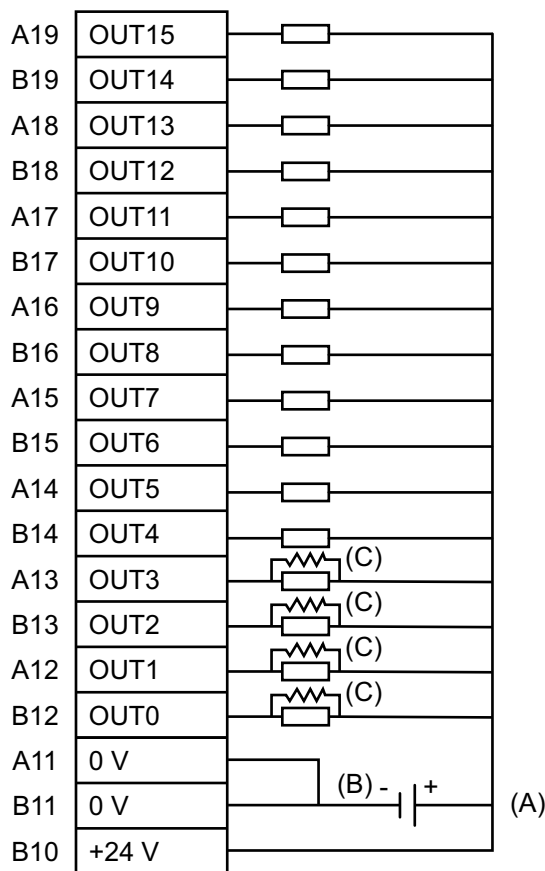

- A. 24 Vdc External power supply
- B. Sink type
- C. Dummy resistor\*1

\*1 (Example) If the output current is 24 Vdc 50 mA, the output delay time (OFF to ON) is 1.5 μs. If more responsiveness is required or the load is light, install an external dummy resistor to increase the amount of current.

**NOTE:** The output terminals are not electrically protected. A short circuit or poor connection of the output wiring may cause burnout of external devices and this product. If there is a risk of the current exceeding the output rating, connect an appropriate fuse to each output terminal.

**Output Circuit: Source type**

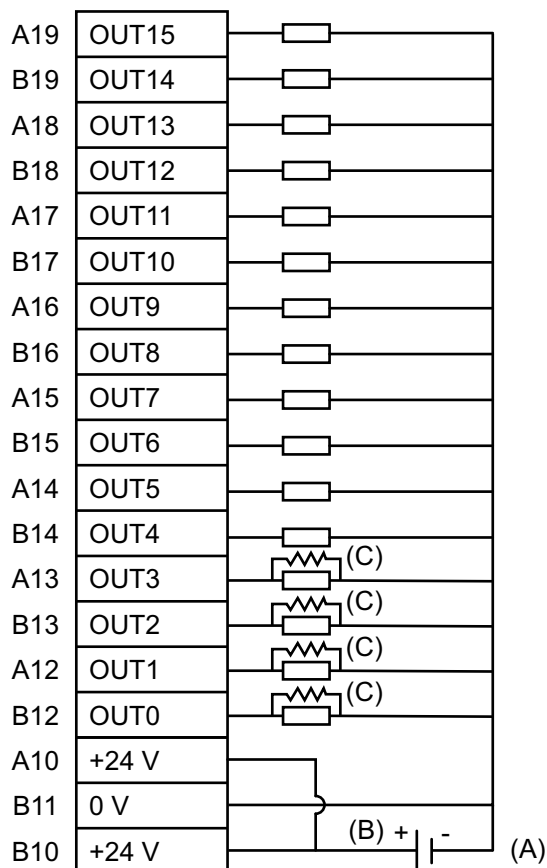

- A. 24 Vdc External power supply
- B. Source type
- C. Dummy resistor\*1

\*1 (Example) If the output current is 24 Vdc 50 mA, the output delay time (OFF to ON) is 1.5 μs. If more responsiveness is required or the load is light, install an external dummy resistor to increase the amount of current.

**NOTE:** The output terminals are not electrically protected. A short circuit or poor connection of the output wiring may cause burnout of external devices and this product. If there is a risk of the current exceeding the output rating, connect an appropriate fuse to each output terminal.

**High-Speed Counter/Pulse Catch Input Specifications**

DIO standard input can be used as a high-speed counter or a pulse catch input. For setup information, refer to your screen editing software manual.

**High-Speed Counter**

Input	24 Vdc open collector	
	Single phase (4-point)	2 phase (1-point or 2-point)
Input points	CT0 (IN0), CT1 (IN2), CT2 (IN4), CT3 (IN6)	CT0 (IN0), CT1 (IN2) (used as pair) CT0: A Phase, CT1: B Phase CT2 (IN4), CT3 (IN6) (used as pair) CT2: A Phase, CT3: B Phase

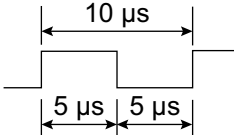
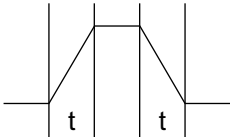
Minimum pulse width (Pulse Input)		
Count speed (Rise, Fall time)	 <p>t = 1 μs or less (100 kpps)</p>	
Phase	1 phase	90 degree phase differential 2 phase signal 1 phase+ directional signal
High speed count frequency	100 kpps	50 kpps
Count edge designation	Available	Not available
Count register	32 bit UP/DOWN counter	
Counter mode change	Set through software	
Upper/Lower limit setting	Not available	
Preload - Prestrobe	Available	
Marker Input (Counter value clear)	None	IN3, IN7

**Pulse Catch Input**

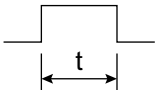
Input	24 Vdc open collector
Input points	IN0, IN2, IN4, IN6
Minimum pulse width (Pulse Input)	Input signal ON width  t = 5 μs or more

**Pulse/PWM Output Specifications**

DIO standard output can be used as a pulse or PWM output. For setup information, refer to your screen editing software manual.

**Pulse Output**

Output points	4
Output method	PLS0...PLS3 (OUT0...OUT3)*1
Load voltage	24 Vdc
Maximum load current	50 mA/1-point
Minimum load current	1 mA
Maximum output frequency	Up to 65 kHz/1-point*1

Pulse acceleration/ Deceleration speed	Available
ON duty	50% $\pm$ 10% (at 65 kHz) <sup>*2</sup>

\*1 Set with the software.

\*2 ON duty error (10%) is reduced if the output frequency is low.

### PWM Output

Output points	4
Output method	PWM0...PWM3 (OUT0...OUT3) <sup>*1</sup>
Load voltage	24 Vdc
Maximum load current	50 mA/1-point
Minimum load current	1 mA
Maximum output frequency	Up to 65 kHz/1-point <sup>*1</sup>
ON duty	19...81% (at 65 kHz) <sup>*2</sup>

\*1 Set with the software.

\*2 ON duty (effective range) is wider if the output frequency is low.

# Dimensions

## What's in This Chapter

External Dimensions (STC-6300TA) .....37

## External Dimensions (STC-6300TA)

### External Dimensions

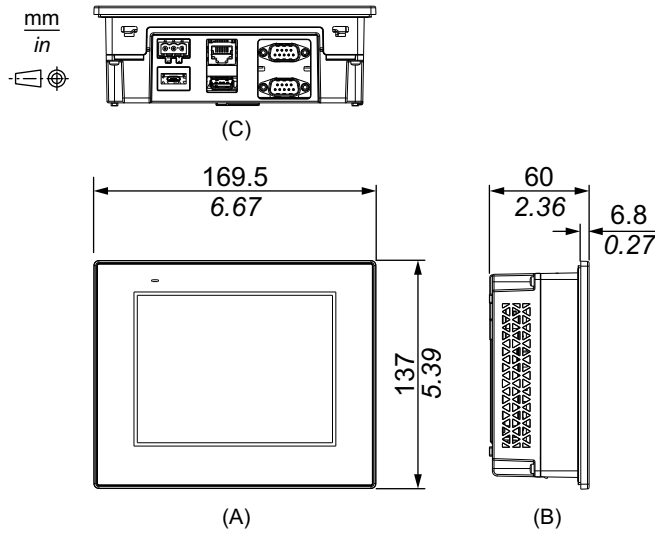

- A. Front
- B. Left
- C. Bottom

## Dimensions with Installation Fasteners

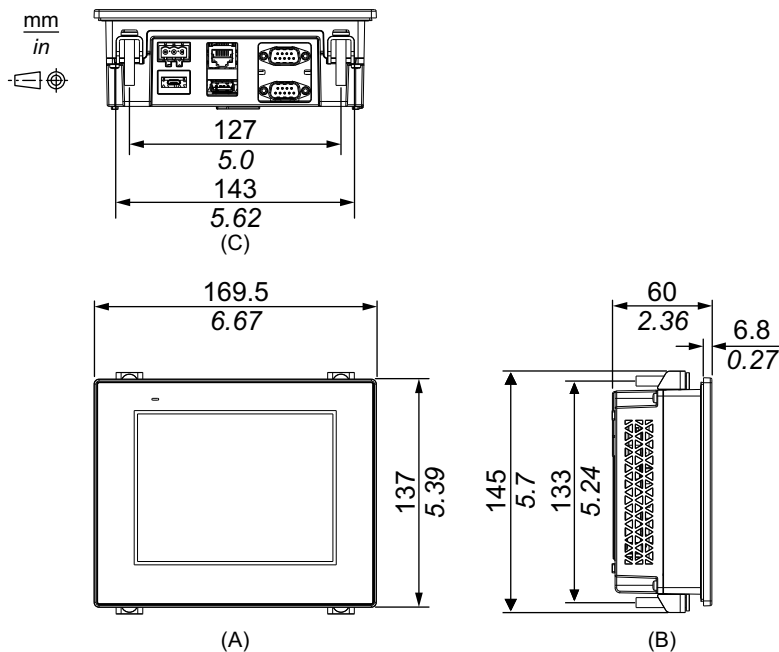

- A. Front
- B. Left
- C. Bottom

## Dimensions with Cables

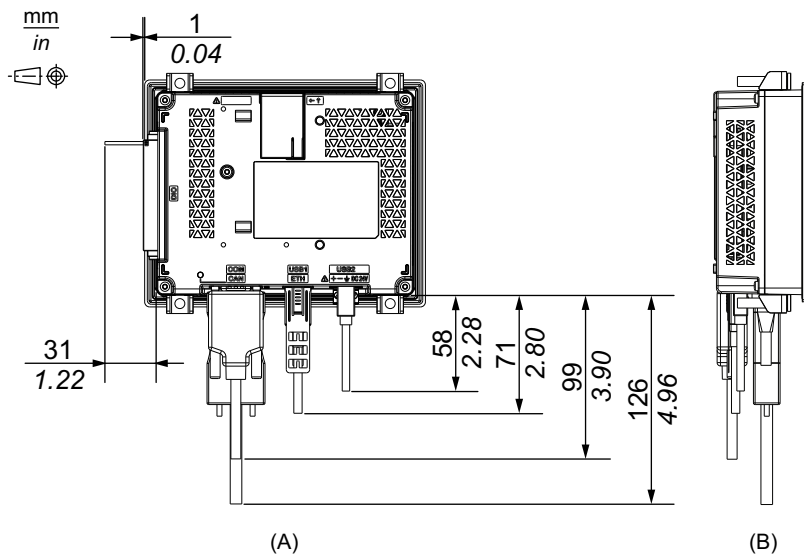

- A. Rear
- B. Left

**NOTE:** All the above values are designed with cable bending in mind. The dimensions given here are representative values depending on the type of connection cable in use. Therefore, these values are intended for reference only.

# Installation and Wiring

## What's in This Chapter

Installation .....	39
Wiring the Power Supply .....	44
USB Cable Clamp .....	48
Isolation Unit Installation Procedure .....	50
Wiring to the DIO Connector.....	52
Installing Expansion Module.....	53

## Installation

### Precautions for Building into an End-use Product

This product is designed for use on flat surfaces of IP65F, UL 50/50E, Type 1, Type 4X (indoor use only), Type 12 and Type 13 enclosures.

Be aware of the following when building this product into an end-use product:

- The rear face of this product is not approved as an enclosure. When building this product into an end-use product, be sure to use an enclosure that satisfies standards as the end-use product's overall enclosure.
- Install this product in an enclosure with mechanical rigidity.
- This product is not designed for outdoor use. UL certification obtained is for indoor use only.
- Install and operate this product with its front panel facing outward.

**NOTE:**

- The necessary torque is 0.5 N•m (4.4 lb-in).
- IP65F is not part of the UL certification.

### Installation Requirements

<b>⚠ WARNING</b>
<p><b>HAZARDOUS IMPACT ON PERIPHERAL DEVICES</b></p> <p>This product must be installed at least 5 m (16.4 ft) away from the magnetic compass.</p> <p><b>Failure to follow these instructions can result in death, serious injury, or equipment damage.</b></p>

<b>⚠ CAUTION</b>
<p><b>RISK OF BURNING INJURY</b></p> <p>Do not touch the bezel or rear chassis during operation.</p> <p><b>Failure to follow these instructions can result in injury or equipment damage.</b></p>

- Check that the installation wall or cabinet surface is flat, in good condition and has no jagged edges. Metal reinforcing strips may be attached to the inside of the wall, near the panel-cut, to increase its rigidity.

- Decide on the thickness of the enclosure wall, based on the level of strength required. Even if the installation wall thickness is within the recommended range for the Panel Cut Dimensions, depending on the wall's material, size, and installation location of this product and other devices, the installation wall could warp. To prevent warping, the installation surface may need to be strengthened.
- Check that the ambient air temperature and the ambient humidity are within their specified ranges in *Environmental Specifications*. When installing this product in a cabinet or enclosure, the ambient air temperature is the cabinet's or enclosure's internal and external temperature.

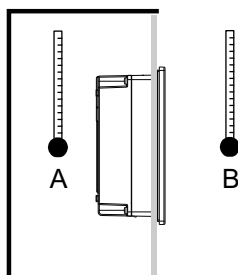

A. Internal temperature

B. External temperature

- Be sure that heat from surrounding equipment does not cause this product to exceed its standard operating temperature.
- When mounting this product in portrait orientation, ensure that the right side of this product faces up. In other words, the DC power connector should be at the bottom.

**NOTE:** For portrait orientation mounting, make sure your screen editing software supports the function.

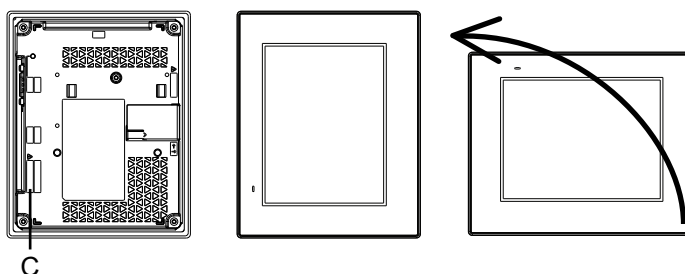

C. Power connector

- When installing this product in a slanted position, the product face should not incline more than 30°.

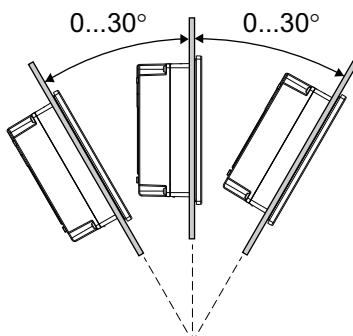



- For easier maintenance, operation and improved ventilation, install this product at least 100 mm (3.94 in) away from adjacent structures and other equipment as shown in the following illustration:

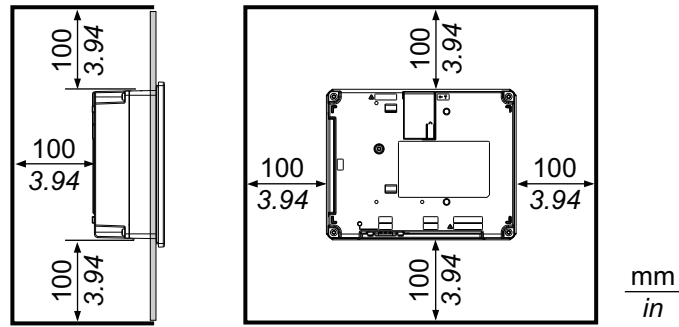

### Pressure Differences

When applying and installing this product, it is important that steps are taken to eliminate any pressure difference between the inside and the outside of the enclosure in which this product is mounted. Higher pressure inside the enclosure can cause delamination of the front membrane of the display. Even a small pressure difference inside the enclosure will act on the large area of the membrane and can result in sufficient force to delaminate the membrane and thus cause failure of the touch capability. Pressure differences can often occur in applications where there are multiple fans and ventilators moving air at different rates in different rooms. Please follow these techniques to ensure that this product's function is not impacted by this mis-application:

- Seal all conduit connections inside of the enclosure, especially those that lead to other rooms that may be at a different pressure.
- Where applicable, install a small weep hole at the bottom of the enclosure to allow equalization of the internal and external pressure.

### Panel Cut Dimensions

Based on the panel cut dimensions, open a mount hole on the panel.

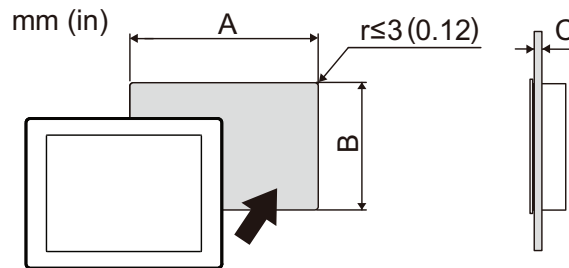

A	B	C
156 mm (+1/-0 mm)	123.5 mm (+1/-0 mm)	1.6...5 mm
(6.14 in [+0.04/-0 in])	(4.86 in [+0.04/-0 in])	(0.06...0.2 in)

### Installation Procedure

This section describes how to install this product to the panel.

**⚡⚠ DANGER****HAZARD OF ELECTRIC SHOCK, EXPLOSION, OR ARC FLASH**

- Remove all power from the device before removing any covers or elements of the system, and prior to installing or removing any accessories, hardware, or cables.
- Unplug the power cable from both this product and the power supply prior to installing or removing the product.
- Always use a properly rated voltage sensing device to confirm power is off where and when indicated.
- Replace and secure all covers or elements of the system before applying power to this product.
- Use only the specified voltage when operating this product. This product is designed to use 24 Vdc. Always check whether your device is DC powered before applying power.
- When using this product in Class I, Division 2, Groups A, B, C, and D hazardous locations, install this product in an enclosure that prevents the operator from touching the back of this product without the use of tools.

**Failure to follow these instructions will result in death or serious injury.**

**NOTICE****EQUIPMENT DAMAGE**

- Always use the installation gasket.
- Keep this product stabilized in the panel cut while you are installing or removing the screw fasteners.

**Failure to follow these instructions can result in equipment damage.**

1. Place the product face down on a clean, flat, level surface.
2. Check that this product's gasket is seated securely into the bezel's groove, which runs around the perimeter of the display panel frame.

**NOTE:** Always use the installation gasket, since it absorbs vibration in addition to repelling water. For the procedure on replacing the installation gasket, refer to Replacing the Installation Gasket.

3. Based on this product's Panel Cut Dimensions, open a mount-hole on the panel and attach this product to the panel from the front side.

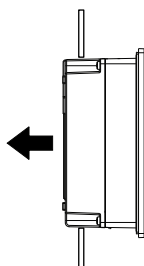

4. Insert the installation fastener hooks into the insertion slots of this product.

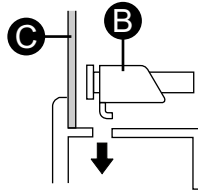
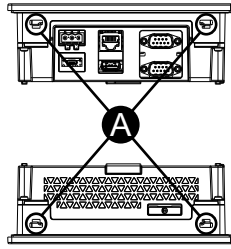

- A. Insertion slots
- B. Installation fastener
- C. Installation panel

5. In a clockwise direction, tighten the installation fastener's screws with a screwdriver. The necessary torque is 0.5 N•m (4.4 lb-in).

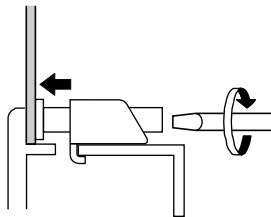

## Removal Procedure

This section describes how to remove this product from the panel.

### **⚠️⚠️ DANGER**

#### **HAZARD OF ELECTRIC SHOCK, EXPLOSION, OR ARC FLASH**

- Remove all power from the device before removing any covers or elements of the system, and prior to installing or removing any accessories, hardware, or cables.
- Unplug the power cable from both this product and the power supply prior to installing or removing the product.
- Always use a properly rated voltage sensing device to confirm power is off where and when indicated.

**Failure to follow these instructions will result in death or serious injury.**

**▲ CAUTION****RISK OF INJURY**

Do not drop this product when you remove it from the panel.

- Hold this product in place after removing the fasteners.
- Use both hands.
- While pushing on the hook, be careful not to hurt your fingers.

**Failure to follow these instructions can result in injury or equipment damage.**

**NOTICE****EQUIPMENT DAMAGE**

- Keep this product stabilized in the panel cut while you are installing or removing the screw fasteners.
- To avoid damage, remove this product while pushing the hook or by making sure the lock does not touch the panel.

**Failure to follow these instructions can result in equipment damage.**

1. Loosen the screws of the installation fasteners and remove them.
2. Slowly remove this product from the panel.

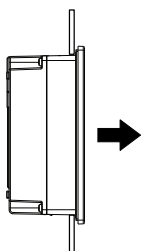

## Wiring the Power Supply

### DC Power Cord Preparation

- Make sure the ground wire is either the same or heavier gauge than the power wires.
- Do not use aluminum wires in the power supply's power cord.
- If the ends of the individual wires are not twisted correctly, the wires may create a short circuit. When inserting a wire into the connector, hold down the opening button and insert the wire while the internal spring is depressed. Alternatively, you can crimp and insert either a pin terminal or ferrule terminal.
- The conductor type is solid or stranded wire.
- Use copper wire rated for 75 °C (167 °F) or higher.
- Use the SELV (Safety Extra-Low Voltage) circuit and LIM (Limited Energy) circuit for DC input.

Power cord cross sectional area	0.75...2.5 mm <sup>2</sup> (18...13 AWG)*1
Conductor type	Solid or stranded wire

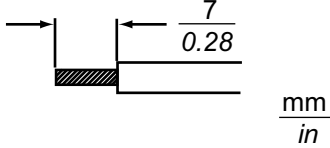
Conductor length	
Recommended screwdriver	Flat-head screwdriver (size 0.6 x 3.5 mm)

\*1 For UL compatibility, use AWG 14 or AWG 13.

## How to Connect the DC Power Cord

### ⚠️⚠️ DANGER

**HAZARD OF ELECTRIC SHOCK, EXPLOSION, OR ARC FLASH**

- Remove all power from the device before removing any covers or elements of the system, and prior to installing or removing any accessories, hardware, or cables.
- Remove power before wiring this product's power terminals.
- Always use a properly rated voltage sensing device to confirm power is off where and when indicated.
- Replace and secure all covers or elements of the system before applying power to this product.
- Use only the specified voltage when operating this product. This product is designed to use 24 Vdc. Always check whether your device is DC powered before applying power.
- Since this product is not equipped with a power switch, be sure to connect a power switch to the power supply.
- Be sure to ground this product's FG terminal.

**Failure to follow these instructions will result in death or serious injury.**

**NOTE:**

- The SG and FG terminals are connected internally in this product.
- When the FG terminal is connected, be sure the wire is grounded. Not grounding this product can result in excessive electromagnetic interference (EMI).

**DC Power Connector**

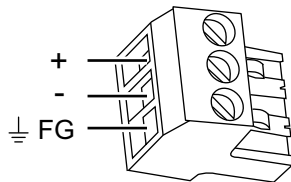

+	24 Vdc
-	0 Vdc
FG	Functional ground (Connect the FG terminal properly to ground.)

**NOTE:** Model number CA5-DCCNM-01 (or MSTB2,5/3-ST-5,08 by Phoenix Contact)

### Connection Procedure

1. Confirm the power cord is not connected to the power supply.
2. Check the rated voltage.
3. Remove the DC power connector from this product.
4. Strip the membrane of the power cord, and twist the wire ends.
5. Insert each power cord wire into its corresponding hole. Fasten the screws of the DC power connector to clamp the wire in place.

**NOTE:**

- The necessary torque is 0.56 N•m (5 lb-in).
- Do not solder the cable connection.

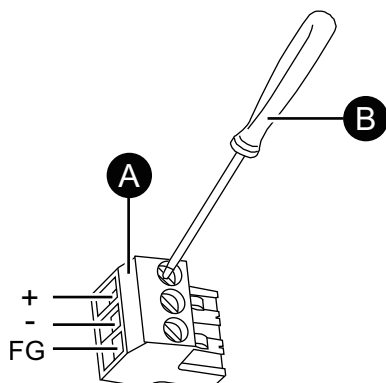

- A. DC power connector  
 B. Flat-blade screwdriver (size 0.6 x 3.5 mm)

6. After inserting all three power cord wires, insert the DC power connector into the power connector on this product.

## Power Supply Precautions

### **⚠ DANGER**

#### **SHORT CIRCUIT, FIRE, OR UNINTENDED EQUIPMENT OPERATION**

- Install and fasten this product in an installation panel or cabinet prior to connecting power supply and communication lines.
- Securely attach power cables to an installation panel or cabinet.
- Avoid excessive force on the power cable.

**Failure to follow these instructions will result in death or serious injury.**

- This product's power cord should not be bundled with or kept close to main circuit lines (high voltage, high current), power lines, or input/output lines, and their various systems should be kept separate. When power lines cannot be wired via a separate system, use shielded cables for input/output lines.
- An independent DC power supply is recommended for this product. (The DC power supply should be located close to the product, with twisted pair cabling as short as possible.)
- To increase noise resistance, attach a ferrite core to the power cable.

## Power Supply Connections

- Use the SELV (Safety Extra-Low Voltage) circuit and LIM (Limited Energy) circuit for DC input.
- If the voltage variation is outside the prescribed range, connect a regulated power supply.

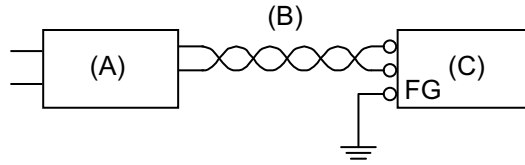

- A. Regulated power supply
- B. Twisted-pair cord
- C. This product

## Grounding

### Independent Grounding

Always ground the FG (functional ground) terminal. Be sure to separate this product from the FG of other devices as shown below.

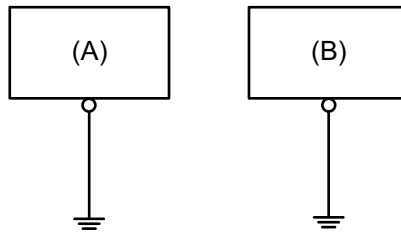

- A. This product
- B. Other equipment

## Precautions

- Check that the grounding resistance is 100  $\Omega$  or less.\*1
- The FG wire should have a cross sectional area 2 mm<sup>2</sup> (AWG14) or greater\*1. Create the connection point as close as possible to this product, and make the wire as short as possible. When using a long grounding wire, replace the thin wire with a thicker wire, and place it in a duct.
- The SG and FG terminals are connected internally in this product. When connecting the SG line to another device, be sure that no ground loop is formed.

\*1 Observe local codes and standards.

## Common Grounding

Electromagnetic Interference (EMI) can be created if devices are improperly grounded. EMI can cause loss of communication. If exclusive grounding is not possible, use a common grounding point as shown in the configuration below. Do not use any other configuration for common grounding.

## Correct grounding

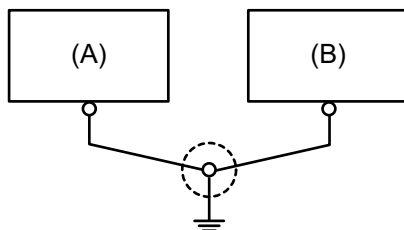

- A. This product
- B. Other equipment

## Incorrect grounding

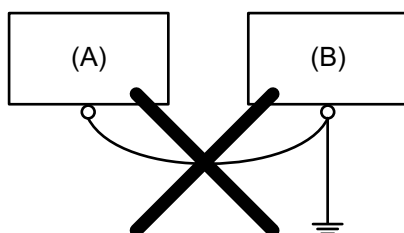

- A. This product
- B. Other equipment

## USB Cable Clamp

### Precautions for Connecting the USB Cable

#### ⚠ WARNING

##### EXPLOSION HAZARD

- Verify the power, input, and output (I/O) wiring are in accordance with Class I, Division 2 wiring methods.
- Substitution of any components may impair suitability for Class I, Division 2.
- Do not disconnect equipment while the circuit is live or unless the area is known to be free of ignitable concentrations.
- Remove power before attaching or detaching any connectors to or from this product.
- Ensure that power, communication, and accessory connections do not place excessive stress on the ports. Consider the vibration in the environment when making this determination.
- Securely attach power, communication, and external accessory cables to the panel or cabinet.
- Use only commercially available USB cables.
- Use only non-incendive USB configurations.
- Suitable for use in Class I, Division 2, Groups A, B, C, D Hazardous Locations.
- Confirm that the USB cable has been attached with the USB cable clamp before using the USB interface.

**Failure to follow these instructions can result in death, serious injury, or equipment damage.**



## Attaching USB Clamp Type A

When using a USB device, attach a USB cable clamp to the USB interface to prevent the USB cable from being disconnected.

**NOTE:** Watch your fingers. The edge of the clip is sharp.

1. Mount the clip to the USB mark  connector shell so that it overlaps. The clip matches the 27 to 43.5 mm (1.06 to 1.71 in) length of the USB connector.

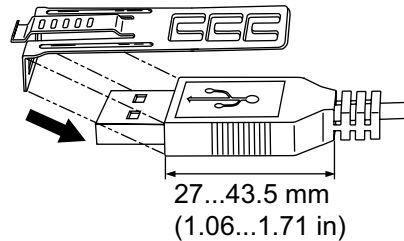

2. Align the clip and the USB cable connector shell. Adjust the position of the holes where the clip is attached. To ensure stability, select the clip-hole position that is closest to the base of the connector shell.

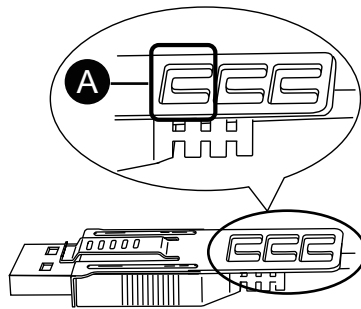

A. Hole for tie to pass through

3. As shown, pass the tie through the clip hole. Next, turn the tie and pass it through the head so that the USB cable can pass through the center of the tie loop. The clip is now attached to the USB cable.

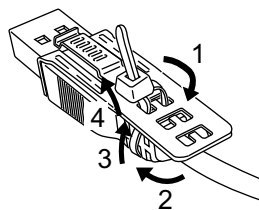

**NOTE:**

- Check the direction of the head beforehand. Make sure the USB cable is through the center of the tie loop and that the tie can pass through the head.
- You can substitute the tie provided with PFXZCBCLUSA1, or other commercially available ties with a width of 4.8 mm (0.19 in) and thickness of 1.3 mm (0.05 in).

4. While pressing the grip on the clip, insert the cable from step 3 all the way into the USB host interface. Make sure that the clip tab is secured to the USB cable attached to this product.

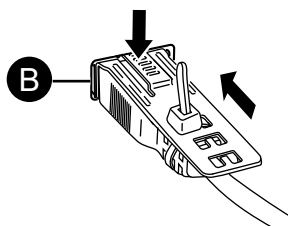

B. USB Type A interface

## Removing USB Clamp Type A

Remove the USB cable while pushing the grip section of the clip.

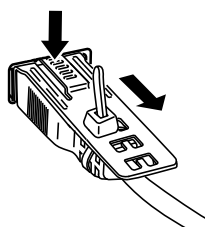

## Isolation Unit Installation Procedure

You can install the Isolation Unit or USB/RS-422/485 Conversion Adapter to the back of this product or to the installation panel. For details such as settings when using the Isolation Unit or USB/RS-422/485 Conversion Adapter, refer to the product manual.

### **⚡⚠ DANGER**

#### **HAZARD OF ELECTRIC SHOCK OR EXPLOSION**

Prior to connecting the Isolation Unit or USB/RS-422/485 Conversion Adapter to this product, confirm that this product's power supply is completely turned OFF.

**Failure to follow these instructions will result in death or serious injury.**

#### **NOTE:**

- Install the Isolation Unit or USB/RS-422/485 Conversion Adapter to a stable surface.
- Do not leave the Isolation Unit or USB/RS-422/485 Conversion Adapter hanging by its cord.
- Be careful with wire placement. Overlapping cords may cause noise.
- Installing the USB/RS-422/485 Conversion Adapter to this product is the same as the following procedure.

1. Check the locations of two screw holes on the rear of this product.

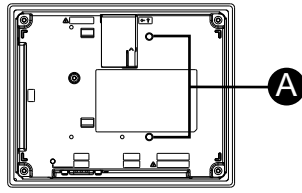

A. Screw hole

2. Install one of the two attachment screws included in the Isolation Unit to this product. Use a torque of 0.5 N•m (4.4 lb-in).

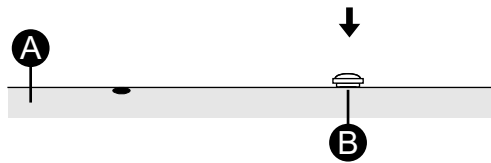

A. This product  
 B. Attachment screw

3. Attach the Isolation Unit to this product.

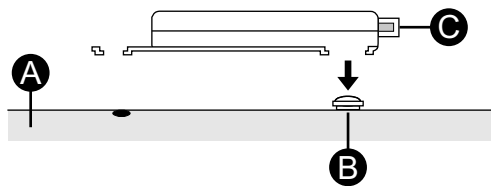

A. This product  
 B. Attachment screw  
 C. Isolation unit

4. Slide the Isolation Unit in the direction of the arrow so the Isolation Unit is hooked by the screw from Step 2.



5. Secure the Isolation Unit in place with another attachment screw. Use a torque of 0.5 N•m (4.4 lb-in).

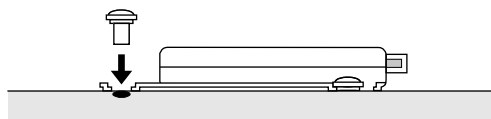

# Wiring to the DIO Connector

## DIO Interface Cable Preparation

- If the ends of the wires are not twisted correctly, the wires may create a short circuit.
- Strip wires only to the required length. If the strip length is too long, the conductive part may protrude from the wire insertion opening and may cause an electric shock or a short circuit with other wires. If the strip is too short, the wire contact may not be a good conductor.
- Do not solder the stranded wire. This could lead to a bad or poor contact.
- When wiring, pay attention to the wire arrangement, installation position and direction to minimize stress on the connector. Affix the cable near the product by using the cable clamp and set it loosely as not to place tension on the connector.
- The connectors are a spring clamp type.

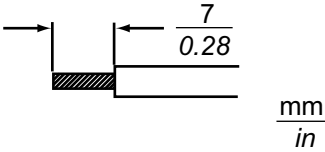
DIO cable cross sectional area	0.20...0.82 mm <sup>2</sup> (AWG 24...18) (UL1015 or UL1007)
Conductor type	Stranded wire
Conductor length	
Recommended screwdriver* <sup>1</sup>	Blade thickness: 1.5 mm (0.06 in) Blade width: 2.4 mm (0.09 in)

\*1 The screwdriver tip should be flat, as indicated, in order to access the narrow hole of the connector. The point shape must be DIN5264A and meet standard DN EN60900.

Shape of the screwdriver tip



## How to Connect the DIO Cable

### NOTE:

- Insert the flathead screwdriver approximately 4 mm. Forceful insertion may break the inside of the connector and lead to a bad or poor contact.
  - Do not rotate the blade of the screwdriver inside the tool insertion hole.
1. Insert the screwdriver diagonally into the tool insertion hole of the DIO connector.
  2. Insert the screwdriver so that it is perpendicular to the center wall.

- The adjacent wire insertion hole opens. With the flathead screwdriver still inserted, insert the wire into the wire insertion hole.

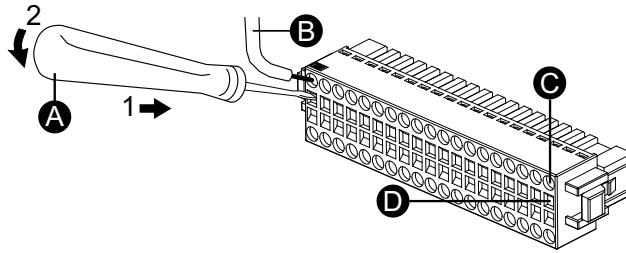

- A. Screwdriver
- B. Wire
- C. Wire insertion hole
- D. Tool insertion hole

- Remove the flathead screwdriver from the tool insertion hole. The wire insertion hole closes and the wire is secured. To remove the wire, insert the flathead screwdriver into the corresponding tool insertion hole and follow steps 1 and 2 to remove the wire.
- Insert the wired DIO connector straight into the DIO interface of this product.

## ⚠ WARNING

### UNINTENDED EQUIPMENT OPERATION

Do not turn on external I/O devices before the transfer of project data to the product is complete.

**Failure to follow these instructions can result in death, serious injury, or equipment damage.**

## Installing Expansion Module

### TM3 Module Installation Procedure

This section describes how to connect the Modicon TM3 I/O Expansion Module to the expansion module interface on the back of this product. Up to two TM3 modules can be connected to the back of this product.

#### NOTE:

- Only one TM3 32-point module can be connected to the back of this product. When connecting the 32-point module, please attach it as the first module. Do not attach the 32-point module as the second module.
- By using the following optional accessories, you can connect more than two TM3 I/O expansion modules. For the connection method, refer to the TM3 module manual.
  - Modicon TM3 Remote Transmitter Module (TM3XTRA1)
  - Modicon TM3 Remote Receiver Module (TM3XREC1)
  - Cable for connecting transmitter module and receiver module (refer to the module manual)

- Place the product face down on a clean, flat, level surface.

2. While pressing the "PUSH" mark on the expansion module interface cover, slide the cover towards the top of the product.

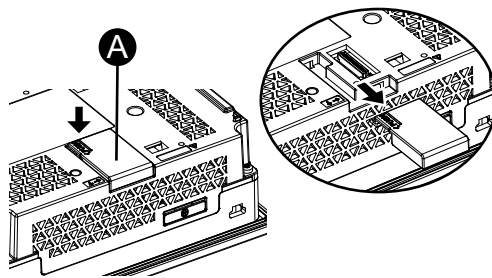

A. Expansion module interface cover

3. Insert the TM3 module's expansion connector into the expansion module interface.

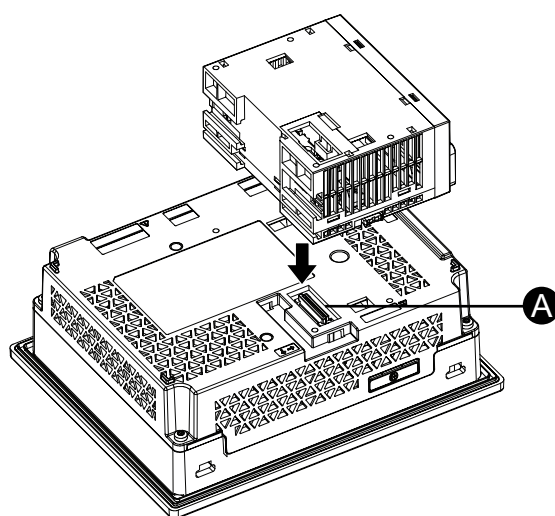

A. Expansion module interface

4. Push the locking device at the top of the TM3 module to secure the TM3 module.

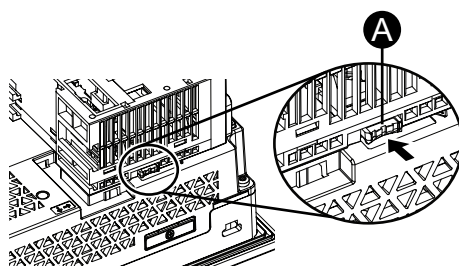

A. Locking device

5. Attach the TM3 module securing hook to the overlap between the TM3 module and this product. Hook the upper protrusion of the securing hook onto this product and the TM3 module, then push in the bottom part of the hook.

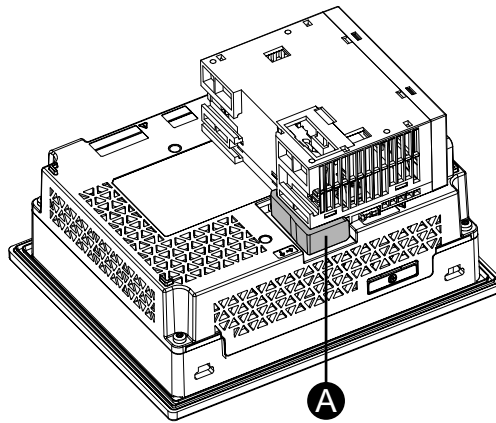

A. TM3 module securing hook

6. Attach the second TM3 module to the first TM3 module and secure them with the latch button in the same manner as described in step 4.

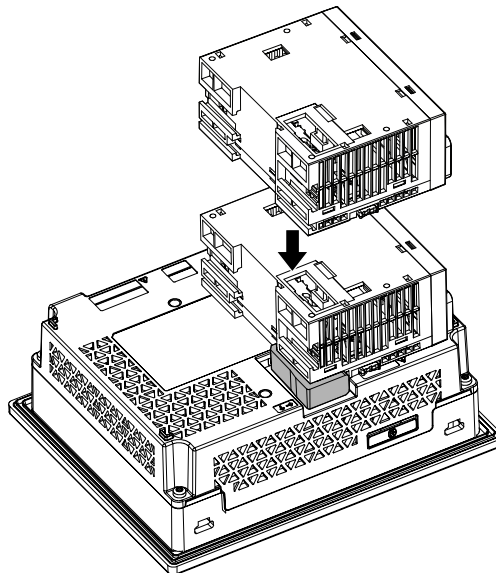

7. Attach the TM3 module securing hook to the overlap between the first and second TM3 modules in the same manner as described in step 5.

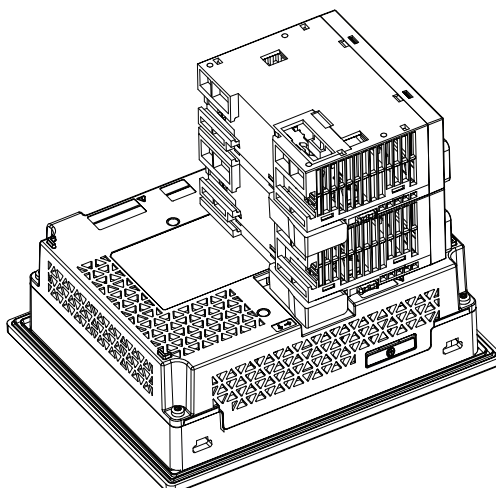

## TM3 Module Removal Procedure

This section describes how to remove the TM3 module from the back of this product.

1. Place the product face down on a clean, flat, level surface.
2. Remove the TM3 module securing hook from this product. Remove the hook from the bottom part first.

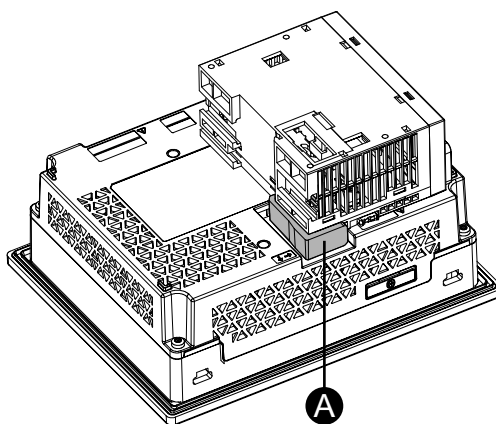

A. TM3 module securing hook

3. Push in the locking device on the bottom of the TM3 module to unlock it.

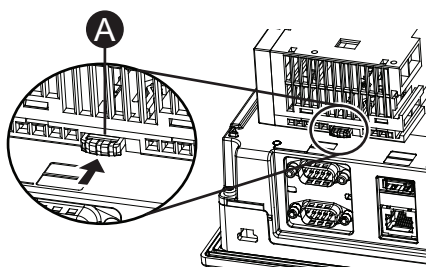

A. Locking device



4. Remove the TM3 module from this product.

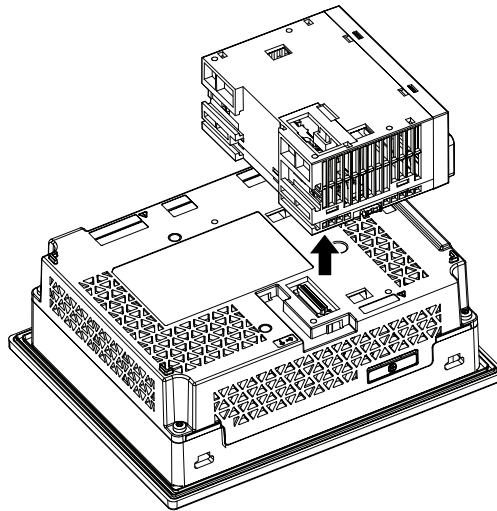

# Maintenance

## What's in This Chapter

Regular Cleaning .....	58
Periodic Check Points.....	58
Replacing the Installation Gasket.....	59
Replacing the Battery .....	59
Replacing the Backlight .....	61
After-sales Service .....	61

## Regular Cleaning

### Cleaning This Product

#### **NOTICE**

##### **EQUIPMENT DAMAGE**

- Power off this product before cleaning it.
- Do not use hard or pointed objects to operate the touch panel.
- Do not use paint thinner, organic solvents, or a strong acid compound to clean the unit.

**Failure to follow these instructions can result in equipment damage.**

When this product gets dirty, wipe this product with a soft, dry cloth or a soft cloth soaked in only water and wrung tightly.

**NOTE:** When the product is very dirty, soak the soft cloth in water with a neutral detergent, wring the cloth tightly and wipe the product while avoiding the product label.

## Periodic Check Points

### Operation Environment

- Is the ambient air temperature within the allowable range? Refer to Environmental Specifications.
- Is the ambient air humidity within the specified range? Refer to Environmental Specifications.
- Is the operating atmosphere free of corrosive gasses?

When this product is inside a panel, the ambient environment refers to the interior of the panel.

### Electrical Specifications

- Is the input voltage appropriate? Refer to Electrical Specifications.
- Are all power cords and cables connected properly? Are there any loose cables?
- Are all installation fasteners holding the unit securely?
- Are there scratches or traces of dirt on the installation gasket?

## Unit Disposal

When disposing this product, dispose it in a manner appropriate to, and in accordance with, your country's industrial machinery disposal/recycling standards.

## Replacing the Installation Gasket

The installation gasket provides protection against dust and moisture. The gasket must be inserted correctly into the groove for moisture resistance for this product.

### **NOTICE**

#### **GASKET AGING**

- Inspect the gasket periodically as required by your operating environment.
- Replace the gasket at least once a year, or as soon as scratches or dirt become visible.

**Failure to follow these instructions can result in equipment damage.**

### **NOTICE**

#### **EQUIPMENT DAMAGE**

Be careful not to stretch the gasket unnecessarily.

**Failure to follow these instructions can result in equipment damage.**

#### **Installation gasket replacement procedure**

1. Place the product face down on a clean, flat, level surface.
2. Remove the gasket from this product.
3. Attach the new gasket to the display module.

**NOTE:** When using a tool to insert the gasket, make sure the tool does not catch the rubber gasket and cause a tear.

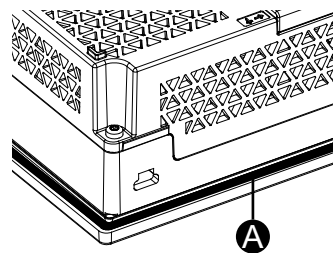

A. Installation gasket

## Replacing the Battery

This product uses a primary battery for data backup of the internal clock. If the battery is depleted, the clock data will be lost. Use only the replacement battery for this product (PFXZGEBT1).

**⚡⚠ DANGER****HAZARD OF ELECTRIC SHOCK, EXPLOSION, OR ARC FLASH**

- Follow the procedures step by step to replace the battery correctly and safely.
- Before replacing the battery, turn off this product's power.

**Failure to follow these instructions will result in death or serious injury.**

**⚠ DANGER****EXPLOSION, FIRE, OR CHEMICAL HAZARD**

- Use only the identical replacement battery for this product.
- Do not cause a short circuit.
- Recycle or properly dispose of used batteries.
- Do not recharge, disassemble or heat above 80 °C (176 °F).
- Use your hands or insulated tools to remove or replace the battery.
- Maintain proper polarity when inserting and connecting a new battery.

**Failure to follow these instructions will result in death or serious injury.**

**NOTICE****LOSS OF DATA**

- Replace the battery regularly every five years after you purchase this product.
- Insert the battery before reconnecting the power supply.
- Allow only qualified personnel to replace the battery.

**Failure to follow these instructions can result in equipment damage.**

**NOTE:**

- Insert the battery before reconnecting the power supply. Otherwise, the clock will not work properly.
- After reconnecting the power supply, set up the clock again. Refer to your screen editing software manual on how to set up the clock.

**Battery replacement procedure**

1. Disconnect the power supply from this product.
2. Touch the housing or ground connection to discharge any electrostatic charge from your body.
3. Place the product face down on a clean, flat, level surface.
4. Open the battery slot on the top of this product.

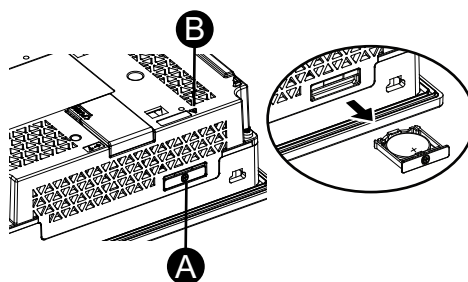

A. Battery slot

B. Safety alert symbol (see the previous safety messages)

5. Remove the spent battery from the tray by touching the battery from the bottom.

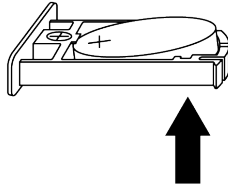

6. Put the new battery on the tray in accordance with the polarity markings in the tray and on the battery.
7. Insert the tray into the battery slot.
8. Reconnect the power supply to this product.

## Replacing the Backlight

Not replaceable. Please contact customer support.

## After-sales Service

For details on after-sales service, refer to our website.

<https://www.pro-face.com/trans/en/manual/1015.html>

Schneider Electric Japan Holdings Ltd.  
Schneider Electric Osaka Building, 4-4-9 Kitahama, Chuo-ku, Osaka  
541-0041  
Japan

+ 81 (0) 6 6208 3133

[www.pro-face.com](http://www.pro-face.com)

As standards, specifications, and design change from time to time,  
please ask for confirmation of the information given in this publication.

© 2024 – Schneider Electric Japan Holdings Ltd. All rights reserved.

STC6000-MM01-EN.02