

STW6000 Series

Hardware Manual

STW6000-MM01-EN.05
12/2024

Legal Information

The information provided in this document contains general descriptions, technical characteristics and/or recommendations related to products/solutions.

This document is not intended as a substitute for a detailed study or operational and site-specific development or schematic plan. It is not to be used for determining suitability or reliability of the products/solutions for specific user applications. It is the duty of any such user to perform or have any professional expert of its choice (integrator, specifier or the like) perform the appropriate and comprehensive risk analysis, evaluation and testing of the products/solutions with respect to the relevant specific application or use thereof.

The Pro-face brand and any trademarks of Schneider Electric SE and its subsidiaries referred to in this document are the property of Schneider Electric SE or its subsidiaries. All other brands may be trademarks of their respective owner.

This document and its content are protected under applicable copyright laws and provided for informative use only. No part of this document may be reproduced or transmitted in any form or by any means (electronic, mechanical, photocopying, recording, or otherwise), for any purpose, without the prior written permission of Schneider Electric.

Schneider Electric does not grant any right or license for commercial use of the document or its content, except for a non-exclusive and personal license to consult it on an "as is" basis.

Schneider Electric reserves the right to make changes or updates with respect to or in the content of this document or the format thereof, at any time without notice.

To the extent permitted by applicable law, no responsibility or liability is assumed by Schneider Electric and its subsidiaries for any errors or omissions in the informational content of this document, as well as any non-intended use or misuse of the content thereof.

Table of Contents

Safety Information	5
About the Book	6
Cybersecurity	10
Cybersecurity Guideline	10
Overview	11
Model Numbers	11
Package Contents	11
Certifications and Standards	13
Device Connectivity	14
System Design	14
Accessories	15
Parts Identification and Functions	17
Parts Identification	17
Parts Identification (STW-6200WA)	17
Parts Identification (STW-6400WA)	18
Parts Identification (STW-6500WA/6600WA/6700WA)	19
LED Indications	20
Status LED	20
Ethernet LED	20
Specifications	21
General Specifications	21
Electrical Specifications	21
Environmental Specifications	22
Structural Specifications	22
Functional Specifications	24
Display Specifications	24
Touch Panel	25
Memory	25
Clock	25
Interface Specifications	25
Specifications of Each Interface	25
Dimensions	27
STW-6200WA	27
STW-6400WA	29
STW-6500WA	30
STW-6600WA	32
STW-6700WA	33
Installation and Wiring	36
Installation	36
Precautions for Building into an End-use Product	36
Installation Requirements	36
Panel Cut Dimensions	38
Installation Procedure (STW-6200WA)	39
Installation Procedure (STW-64/65/66/6700WA)	43
Removal Procedure	45
Wiring the Power Supply	46
Connecting the DC Power Cord	46
Power Supply Precautions	48

Grounding	48
USB Cable Clamp	50
USB Clamp Type A (1 port)	50
Display/Browser Settings	52
Startup Settings	52
Settings Workflow	52
Update the System	54
Web Browser	55
Operation of Web Browser	55
How to Display Configuration Menu	56
Configuration Menu	57
Save and Exit	57
Screen	58
Interface	58
Boot	59
Server	60
Network	61
System	62
Login Statistics	63
Information	64
Maintenance	65
Regular Cleaning	65
Periodic Check Points	65
Replacing the Installation Gasket	66
Replacing the Backlight	66
After-sales Service	67

Safety Information

Important Information

Read these instructions carefully, and look at the equipment to become familiar with the device before trying to install, operate, service, or maintain it. The following special messages may appear throughout this documentation or on the equipment to warn of potential hazards or to call attention to information that clarifies or simplifies a procedure.



The addition of this symbol to a “Danger” or “Warning” safety label indicates that an electrical hazard exists which will result in personal injury if the instructions are not followed.



This is the safety alert symbol. It is used to alert you to potential personal injury hazards. Obey all safety messages that follow this symbol to avoid possible injury or death.

DANGER

DANGER indicates a hazardous situation which, if not avoided, **will result in** death or serious injury.

WARNING

WARNING indicates a hazardous situation which, if not avoided, **could result in** death or serious injury.

CAUTION

CAUTION indicates a hazardous situation which, if not avoided, **could result in** minor or moderate injury.

NOTICE

NOTICE is used to address practices not related to physical injury.

Please Note

Electrical equipment should be installed, operated, serviced, and maintained only by qualified personnel. No responsibility is assumed by Schneider Electric for any consequences arising out of the use of this material.

A qualified person is one who has skills and knowledge related to the construction and operation of electrical equipment and its installation, and has received safety training to recognize and avoid the hazards involved.

About the Book

Document Scope

This document describes the specifications, installation, operation, and maintenance of the STW6000 Series, which is an HMI (Human Machine Interface) device used in industrial or factory automation systems.

This document is intended for users who design systems, or install and maintain components.

Validity Note

This document is valid for STW6000 Series.

The characteristics of the products described in this document are intended to match the characteristics that are available on www.pro-face.com. As part of our corporate strategy for constant improvement, we may revise the content over time to enhance clarity and accuracy. If you see a difference between the characteristics in this document and the characteristics on www.pro-face.com, consider www.pro-face.com to contain the latest information.

Registered Trademarks

Microsoft and Windows are registered trademarks of Microsoft Corporation in the United States and/or other countries.

QR Code is a registered trademark of DENSO WAVE INCORPORATED in Japan and other countries.

Product names used in this manual may be the registered trademarks owned by the respective proprietors.

Available Languages of this Document

This document is available in these languages:

- English (STW6000-MM01-EN)
- French (STW6000-MM01-FR)
- German (STW6000-MM01-DE)
- Spanish (STW6000-MM01-ES)
- Italian (STW6000-MM01-IT)
- Chinese (STW6000-MM01-CS)
- Japanese (STW6000-MM01-JA)

Related Documents

You can download the manuals related to this product, such as the software manual, from the Pro-face download page (www.pro-face.com/trans/en/manual/1085.html).

Information on Non-Inclusive or Insensitive Terminology

As a responsible, inclusive company, Schneider Electric is constantly updating its communications and products that contain non-inclusive or insensitive terminology. However, despite these efforts, our content may still contain terms that are deemed inappropriate by some customers.

Product Related Information

If the equipment is used in a manner not specified by the manufacturer, the protection provided by the equipment may be impaired.

DANGER

HAZARD OF ELECTRIC SHOCK, EXPLOSION, OR ARC FLASH

- Remove all power from the device before removing any covers or elements of the system, and prior to installing or removing any accessories, hardware, or cables.
- Unplug the power cable from both this product and the power supply prior to installing or removing the product.
- Always use a properly rated voltage sensing device to confirm power is off where and when indicated.
- Replace and secure all covers or elements of the system before applying power to this product.
- Use only the specified voltage when operating this product. This product is designed to use 24 Vdc. Always check whether your device is DC powered before applying power.

Failure to follow these instructions will result in death or serious injury.

DANGER

EXPLOSION HAZARD

- Do not use this product in hazardous environments.
- Do not connect or disconnect this product unless power has been switched off or the area is known to be non-hazardous.
- Do not attempt to install, operate, modify, maintain, service, or otherwise alter this product except as permitted in this manual.
- Confirm that the USB cable has been attached with the USB cable clamp before using the USB interface.

Failure to follow these instructions will result in death or serious injury.

Critical alarm indicators and system functions require independent and redundant protection hardware and/or mechanical interlocks.

When you cycle power, wait at least 10 seconds after it has been turned off. If this product is restarted too quickly, it may not operate correctly.

In the event the screen cannot be properly read, for example, if the backlight is not functioning, it may be difficult or impossible to identify a function. Functions that may present a hazard if not immediately executed, such as a fuel shut-off, must be provided independently of this product. The machine's control system design must take into account the possibility of the backlight no longer functioning and the operator being unable to control the machine or making mistakes in the control of the machine.

⚠ WARNING

LOSS OF CONTROL

- The designer of any control scheme must consider the potential failure modes of control paths and, for certain critical control functions, provide a means to achieve a safe state during and after a path failure. Examples of critical control functions are emergency stop and overtravel stop, power outage and restart.
- Separate or redundant control paths must be provided for critical control functions.
- System control paths may include communication links. Consideration must be given to the implications of unanticipated transmission delays or failures of the link.
- Observe all accident prevention regulations and local safety guidelines.
- Each implementation of this product must be individually and thoroughly tested for proper operation before being placed into service.
- The machine control system design must take into account the possibility of the backlight no longer functioning and the operator being unable to control the machine, or making errors in the control of the machine.

Failure to follow these instructions can result in death, serious injury, or equipment damage.

For additional information, refer to NEMA ICS 1.1 (latest edition), "Safety Guidelines for the Application, Installation, and Maintenance of Solid State Control" and to NEMA ICS 7.1 (latest edition), "Safety Standards for Construction and Guide for Selection, Installation and Operation of Adjustable-Speed Drive Systems" or their equivalent governing your particular location.

⚠ WARNING

UNINTENDED EQUIPMENT OPERATION

- The application of this product requires expertise in the design and programming of control systems. Only persons with such expertise should be allowed to program, install, alter, and apply this product.
- Follow all local and national safety standards.

Failure to follow these instructions can result in death, serious injury, or equipment damage.

⚠ WARNING

UNINTENDED EQUIPMENT OPERATION

- Do not use this product as the only means of control for critical system functions such as motor start/stop or power control.
- Do not use this equipment as the only notification device for critical alarms, such as device overheating or overcurrent.
- Use only the software provided with this product. If you use another software, please confirm the operation and safety before use.

Failure to follow these instructions can result in death, serious injury, or equipment damage.

The following characteristics are specific to the LCD panel and are considered normal behavior:

- LCD screen may show unevenness in the brightness of certain images or may appear different when seen from outside the specified viewing angle. Extended shadows, or crosstalk may also appear on the sides of screen images.
- LCD screen pixels may contain black and white colored spots and color display may seem to have changed.

- When experiencing vibrations within a certain frequency range and vibration acceleration is above what is acceptable, the LCD screen may partially turn white. Once the vibration condition ends, the whitening of the screen is resolved.
- When the same image is displayed on the screen for a long period, an afterimage may appear when the image is changed.
- The panel brightness may decrease when used for a long time in an environment continuously filled with inert gas. To prevent deterioration of panel brightness, regularly ventilate the panel. For more information, please contact customer support.
<https://www.pro-face.com/trans/en/manual/1015.html>

▲ WARNING

SERIOUS EYE AND SKIN INJURY

The liquid in the LCD panel contains an irritant:

- Avoid direct skin contact with the liquid.
- Wear gloves when you handle a broken or leaking unit.
- Do not use sharp objects or tools in the vicinity of the LCD panel.
- Handle the LCD panel carefully to prevent puncture, bursting, or cracking of the panel material.
- If the panel is damaged and any liquid comes in contact with your skin, immediately rinse the area with running water for at least 15 minutes. If the liquid gets in your eyes, immediately rinse your eyes with running water for at least 15 minutes and consult a doctor.

Failure to follow these instructions can result in death, serious injury, or equipment damage.

NOTICE

REDUCTION OF SERVICE LIFE OF PANEL

Change the screen image periodically and try not to display the same image for a long period of time.

Failure to follow these instructions can result in equipment damage.

Cybersecurity

Cybersecurity Guideline

Use this product inside a secure industrial automation and control system. Total protection of components (equipment/devices), systems, organizations, and networks from cyber attack threats requires multi-layered cyber risk mitigation measures, early detection of incidents, and appropriate response and recovery plans when incidents occur. For more information about cybersecurity, refer to the Pro-face HMI/IPC Cybersecurity Guide.

https://www.proface.com/en/download/manual/cybersecurity_guide

WARNING

POTENTIAL COMPROMISE OF SYSTEM AVAILABILITY, INTEGRITY, AND CONFIDENTIALITY

- Change default passwords at first use to help prevent unauthorized access to device settings, controls and information.
- Disable unused ports/services and default accounts, where possible, to minimize pathways for malicious attacks.
- Place networked devices behind multiple layers of cyber defenses (such as firewalls, network segmentation, and network intrusion detection and protection).
- Apply the latest updates and hotfixes to your Operating System and software.
- Use cybersecurity best practices (for example: least privilege, separation of duties) to help prevent unauthorized exposure, loss, modification of data and logs, interruption of services, or unintended operation.

Failure to follow these instructions can result in death, serious injury, or equipment damage.

Overview

What's in This Chapter

Model Numbers..... 11
 Package Contents 11
 Certifications and Standards 13

Model Numbers

Model List

Series	Model name	Model number
STW6000 Series	STW-6200WA	PFXSTW6200WAD
	STW-6400WA	PFXSTW6400WAD
	STW-6500WA	PFXSTW6500WAD
	STW-6600WA	PFXSTW6600WAD
	STW-6700WA	PFXSTW6700WAD

NOTE: All model numbers may be followed by any letter or number.

Model Number Configuration

The following describes the configuration of model numbers.

Digit position												
1	2	3	4	5	6	7	8	9	10	11	12	13
			(model)			(series)	(size)	(type)		(LCD)	(touch panel)	(power supply)
PFX			STW			6	2: 4" 4: 7" 5: 10" 6: 12" 7: 15"	00: Standard		W: Wide TFT	A: Analog	D: DC

Global Code

A global code is assigned to every Pro-face product as a universal model number. For more information on product models and their matching global codes, please refer to the following URL.

<https://www.pro-face.com/trans/en/manual/1003.html>

Package Contents

Verify all items listed here are present in your package.

Please contact customer support immediately if you find anything damaged or missing.

⚠ WARNING

UNINTENDED EQUIPMENT OPERATION

Do not use damaged products or accessories.

Failure to follow these instructions can result in death, serious injury, or equipment damage.

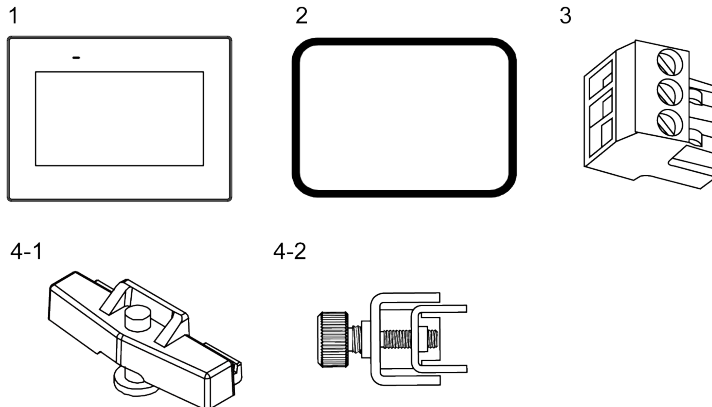

- 1 STW-6•00WA x 1
- 2 Installation gasket (attached to this product) x 1
- 3 DC power supply connector x 1
- 4-1 Installation fastener for: STW-6200WA x 2 pieces
- 4-2 Installation fastener for: STW-64/65/6600WA x 4 pieces, STW-6700WA x 6 pieces
- 5 Installation guide x 1
- 6 Warning/Caution Information x 1

Product Revision and QR Code

You can identify the product version (PV), revision level (RL), and the software version (SV) from the product label.

NOTE: Depending on the model, the product label may not be marked RL.

You can also check the contents of this manual by using the QR code on the product label. Confirm the location of the QR code below and refer to the manual.

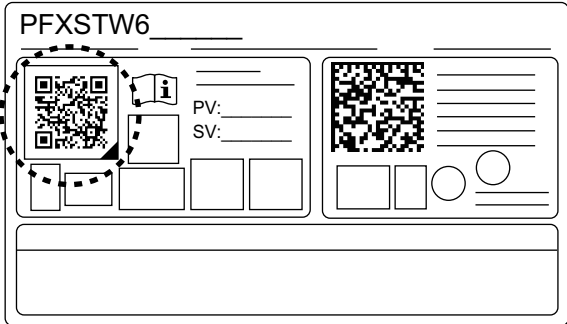

Certifications and Standards

The certifications and standards listed below may include those that are not yet acquired. Please check the product marking and the following URL for the latest acquisition status.

<https://www.pro-face.com/trans/en/manual/1002.html>

Agency Certifications

- Underwriters Laboratories Inc., UL 61010-2-201 and CSA C22.2 N°61010-2-201, Industrial Control Equipment

Compliance Standards

Europe:

CE

- Directive 2014/30/EU (EMC: EN 61131-2)

Australia, New Zealand:

- RCM

Korea

- KC

Hazardous Substances

This product is designed to be compliant with the following environmental regulations, even if the product may not fall directly in the scope of the regulation:

- RoHS, Directive 2011/65/EU and 2015/863/EU
- RoHS China, Standard GB/T 26572
- REACH regulation EC 1907/2006

End of Life (WEEE)

The product contains electronic boards. It must be disposed of in specific treatment channels. The product contains cells and/or storage batteries which must be collected and processed separately when they have run out and at the end of product life (Directive 2012/19/EU).

KC Markings

기종별	사용자안내문
A급 기기 (업무용 방송통신기자재)	이 기기는 업무용(A급) 전자파적합기기로서 판매자 또는 사용자는 이 점을 주의하시기 바라며, 가정외의 지역에서 사용하는 것을 목적으로 합니다.

Device Connectivity

What's in This Chapter

System Design.....	14
Accessories	15

System Design

Product Overview

This product is an industrial display equipped with a dedicated HTML5-compatible browser. As a Web client, the product can access Web servers on the same Intranet and display the server content in the dedicated browser.

- Can connect to HTML5 servers (such as HMI, IPC, PLC, and other external devices with Web server functionality*¹) that support Java Script. You can connect to up to 10 web server devices.
- The dedicated browsers support CSS3 and XML.
- You cannot use this product on the Internet.
- HMI applications do not run on this product.

After turning on this product, you need to set up its display and Web browser settings. For information about settings, refer to *Display/Browser Settings*, page 52.

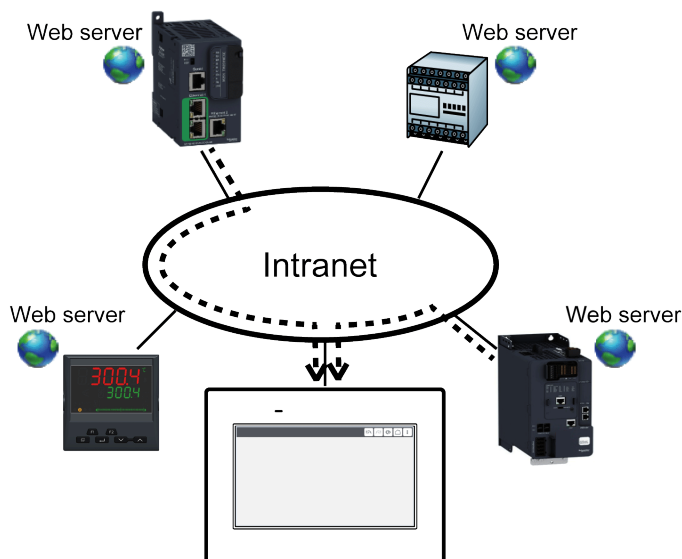

*1 For Web server device connections that have been confirmed, please refer to our website.

<https://www.pro-face.com/trans/en/manual/1103.html>

System Structure

This section describes the system configuration with this product and peripheral equipment.

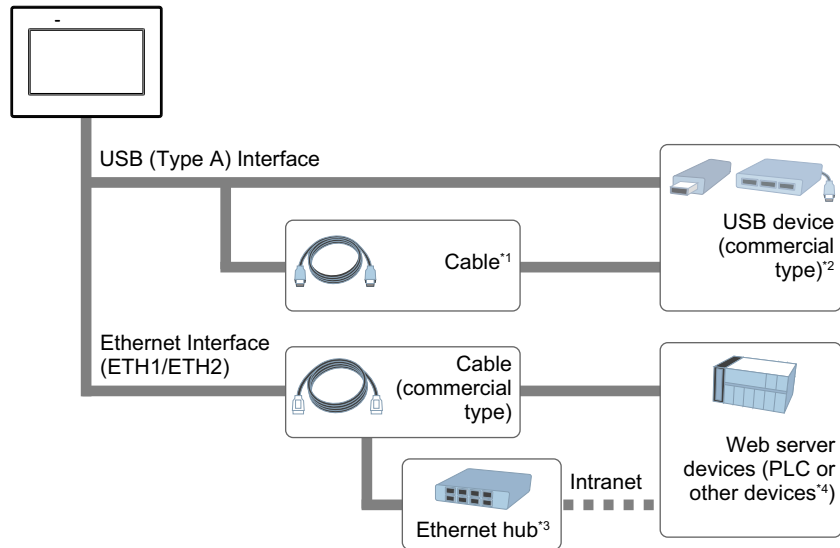

*1 Refer to Accessories, page 15.

*2 A USB storage device, USB keyboard, USB mouse, and USB hub can be used. Multiple USB devices of the same type cannot be connected.

*3 Only for STW-6200WA, an Ethernet hub is required to connect to the Intranet.

*4 For Web server device connections that have been confirmed, please refer to our website.

<https://www.pro-face.com/trans/en/manual/1103.html>

NOTE:

- The number of Ethernet interfaces varies depending on the model. Refer to Parts Identification, page 17.
- Connect USB devices before turning on the product.
- When a USB keyboard is connected, the software keyboard is not displayed.
- Use a FAT32 formatted USB storage.

Accessories

Products may change or be discontinued without notice. Please check our website for the latest information.

<https://www.pro-face.com>

Product name	Product number	Description
USB (Type A) Interface		
USB Front Cable (1 m)	CA5-USBEXT-01	Extension cable that attaches USB interface to front panel.
USB Clamp Type A (1 port)	PFXZCBCLUSA1	Clamp to prevent disconnection of USB cable (USB Type A, 1 port, 5 clamps/ set).
Others		
Screen Protection Sheet	PFXZCDDS122	Disposable, dirt-resistant sheet for 12-inch Wide screen (5 sheets/set).
UV Protection Sheet	PFXZCFUV122	Sheet to protect the display from dirt and ultraviolet light, for 12-inch Wide (1 sheet).
Screen Protection Sheet with UV Protected	PFXZCIDS42	Disposable, dirt-resistant and ultraviolet protection sheet for 4-inch Wide screen (1 sheet /set).

Product name	Product number	Description
	PFXZCIDS72	Disposable, dirt-resistant and ultraviolet protection sheet for 7-inch Wide screen (1 sheet /set).
	PFXZCIDS102	Disposable, dirt-resistant and ultraviolet protection sheet for 10-inch Wide screen (1 sheet /set).
	PFXZCIDS152	Disposable, dirt-resistant and ultraviolet protection sheet for 15-inch Wide screen (1 sheet /set).
Spring Clip	XBTZ3002	Fasteners to attach this product to the mounting surface for STW-6200WA.

Maintenance Accessories

Product name		
Product number	Supported product	Description
Installation Fastener		
ZC9AF31	STW-6200WA	Installation fastener (2 pieces/set).
PFXZCIAFTF1	STW-6400WA, STW-6500WA, STW-6600WA, STW-6700WA	Installation fastener (2 pieces/set).
Installation Gasket		
PFXZCIWG43	STW-6200WA	Provides dust and moisture resistance when this product is installed into a solid panel (1 piece).
PFXZCIWG73	STW-6400WA	
PFXZCIWG103	STW-6500WA	
PFXZCIWG123	STW-6600WA	
PFXZCIWG153	STW-6700WA	
DC Power Supply Connector		
CA5-DCCNM-01	All	Connector to connect DC power supply cables.

Parts Identification and Functions

What's in This Chapter

Parts Identification..... 17
 LED Indications..... 20

Parts Identification

Parts Identification (STW-6200WA)

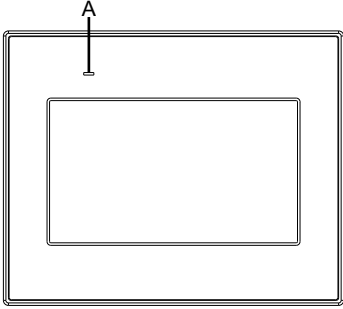
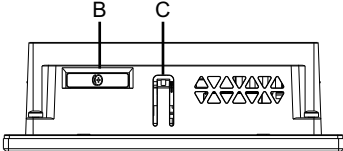
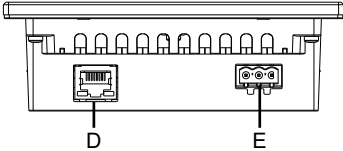
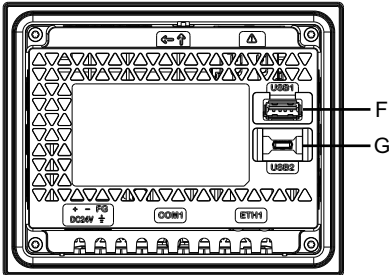
Front	
Top	
Bottom	
Rear	

- A: Status LED
- B: Battery slot*1
- C: Hook
- D: Ethernet interface (ETH1)
- E: Power plug connector

F: USB (Type A) interface

G: USB (micro-B) interface*2

*1 Products do not have a battery.

*2 The USB (micro-B) interface is unavailable.

NOTE: This product does not have a serial interface (COM1).

Parts Identification (STW-6400WA)

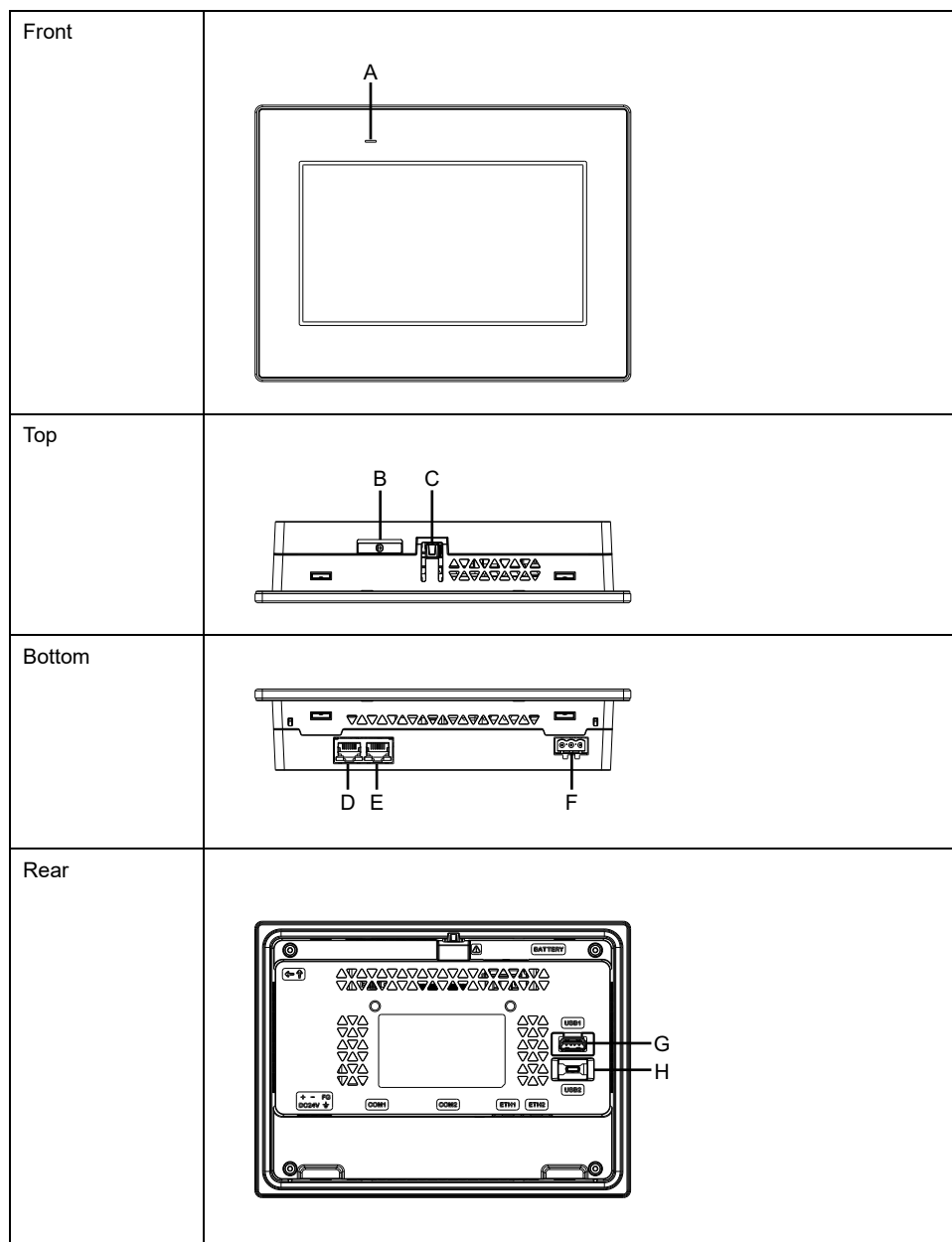

A: Status LED

B: Battery slot*1

C: Hook

D: Ethernet interface (ETH2)*2

E: Ethernet interface (ETH1)*2

F: Power plug connector

G: USB (Type A) interface

H: USB (micro-B) interface*3

*1 Products do not have a battery.

*2 ETH1 and ETH2 have the same IP address and MAC address.

*3 The USB (micro-B) interface is unavailable.

NOTE: This product does not have serial interfaces (COM1 and COM2).

Parts Identification (STW-6500WA/6600WA/6700WA)

NOTE: The figures below show STW-6500WA.

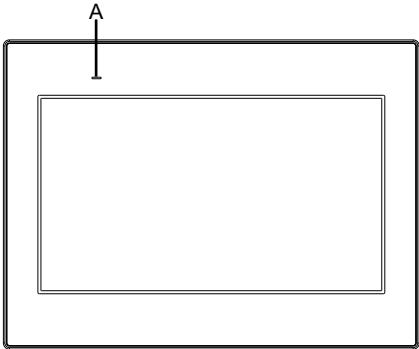
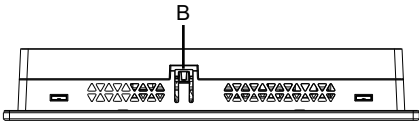
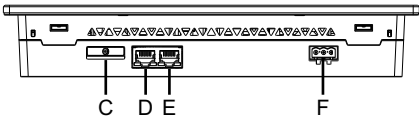
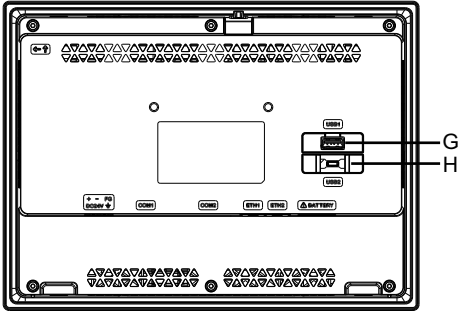
Front	
Top	
Bottom	
Rear	

A: Status LED

B: Hook

C: Battery slot*1

D: Ethernet interface (ETH2)*2

E: Ethernet interface (ETH1)*2

F: Power plug connector

G: USB (Type A) interface

H: USB (micro-B) interface*3

*1 Products do not have a battery.

*2 ETH1 and ETH2 have the same IP address and MAC address.

*3 The USB (micro-B) interface is unavailable.

NOTE: This product does not have serial interfaces (COM1 and COM2).

LED Indications

Status LED

After power is turned on, normal status indicated by the LED is: red light > blinking orange > green light.

Color	Indicator	HMI operation
Green	ON	Offline
		In operation
	Flashing once every 5 seconds	Backlight OFF (Standby Mode)
Orange	Blinking	Software starting up
Red	ON	Power is ON.
-	OFF	Power is OFF.

Ethernet LED

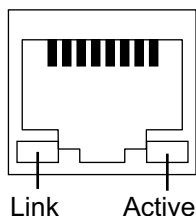

Color	Indicator	Description
Green (Link)	ON	Data transmission is available.
	OFF	No connection or error
Green (Active)	Flashing	Data transmission is occurring.
	OFF	No data transmission

Specifications

What's in This Chapter

General Specifications.....	21
Functional Specifications	24
Interface Specifications	25

General Specifications

Electrical Specifications

Specification		STW-6200WA	STW-6400WA	STW-6500WA
Rated input voltage		24 Vdc		
Input voltage limits		19.2...28.8 Vdc		
Voltage dip/short interruption immunity		2 ms or less (at rated input voltage)	5 ms or less (at rated input voltage)	10 ms or less (at rated input voltage)
Power consumption	Max	6.9 W	9 W	12.6 W
	When power is not supplied to external devices	3.6 W or less	5.5 W or less	9.6 W or less
	When screen turns off the backlight (standby mode)	2.8 W or less	3.6 W or less	4.6 W or less
	In-rush current	30 A or less		
Noise immunity		Noise voltage: 1,000 Vp-p, pulse duration: 1 μ s, rise time: 1 ns (via noise simulator)		
Dielectric strength		1,000 Vac for 1 minute (between power terminal and FG terminal)		
Insulation resistance		500 Vdc, 10 M Ω or more (between power terminal and FG terminal)		

Specification		STW-6600WA	STW-6700WA
Rated input voltage		24 Vdc	
Input voltage limits		19.2...28.8 Vdc	
Voltage dip/short interruption immunity		10 ms or less (at rated input voltage)	
Power consumption	Max	18.4 W	18.5 W
	When power is not supplied to external devices	15 W or less	15 W or less
	When screen turns off the backlight (standby mode)	5.9 W or less	5.4 W or less
	In-rush current	30 A or less	
Noise immunity		Noise voltage: 1,000 Vp-p, pulse duration: 1 μ s, rise time: 1 ns (via noise simulator)	
Dielectric strength		1,000 Vac for 1 minute (between power terminal and FG terminal)	
Insulation resistance		500 Vdc, 10 M Ω or more (between power terminal and FG terminal)	

Environmental Specifications

Use and store this product in areas that conform to the specified conditions.

NOTE: When using any of the options for this product, check the specifications for special conditions or cautions that may apply to this product.

Physical environment	
Ambient air temperature	0...50 °C (32...122 °F)
Storage temperature	-20...60 °C (-4...140 °F)
Ambient air and storage humidity	10%...90% RH (Non condensing, wet bulb temperature 39 °C [102.2 °F] or less)
Dust	0.1 mg/m ³ (10 ⁻⁷ oz/ft ³) or less (non-conductive levels)
Pollution degree	For use in Pollution Degree 2 environment
Corrosive gases	Free of corrosive gases
Atmospheric pressure (operating altitude)	800...1,114 hPa (2,000 m [6,561 ft] or lower)
Mechanical environment	
Vibration resistance	IEC/EN 61131-2 compliant 5...9 Hz Single amplitude 3.5 mm (0.14 in) 9...150 Hz Fixed acceleration: 9.8 m/s ² X, Y, Z directions for 10 cycles (approximately 100 minutes)
Shock resistance	IEC/EN 61131-2 compliant 147 m/s ² , X, Y, Z directions for 3 times
Electrical environment	
Electrical fast transient/burst immunity	IEC 61000-4-4 2 kV: Power port (display unit) 1 kV: Signal ports
Electrostatic discharge immunity	Contact discharge method: 6 kV Air discharge method: 8 kV (IEC/EN 61000-4-2 Level 3)

CAUTION

INOPERATIVE EQUIPMENT

- Do not operate or store the product where chemicals evaporate, or where chemicals are present in the air. Chemicals refer to the following: A) Corrosive chemicals: Acids, alkalines, liquids containing salt, B) Flammable chemicals: Organic solvents.
- Do not allow water, liquids, metal, and wiring fragments to enter the panel case.

Failure to follow these instructions can result in injury or equipment damage.

Structural Specifications

	STW-6200WA	STW-6400WA	STW-6500WA
Grounding	Functional grounding: Grounding resistance of 100 Ω or less, 2 mm ² (AWG 14) or thicker wire, or your country's applicable standard.		
Cooling method	Natural air circulation		

	STW-6200WA	STW-6400WA	STW-6500WA
Structure*1	IP65F, Type 1, Type 4X (indoor use only), Type 13 (on the front panel when properly installed in an enclosure)		
External dimensions (W x H x D)	134.5 x 108.5 x 43 mm (5.3 x 4.27 x 1.69 in)	208 x 153 x 45 mm (8.19 x 6.02 x 1.77 in)	273 x 203 x 47 mm (10.75 x 7.99 x 1.85 in)
Panel cut dimensions (W x H)	118.5 x 92.5 mm (4.67 x 3.64 in)*2 Panel thickness area: 1.6...5 mm (0.06...0.2 in)*3 When using spring clips: Position 1: 1.5...4 mm (0.06...0.16 in) Position 2: 4...6 mm (0.16...0.24 in)	190 x 135 mm (7.48 x 5.31 in)*2 Panel thickness area: 1.6...5 mm (0.06...0.2 in)*3	255 x 185 mm (10.04 x 7.28 in)*2 Panel thickness area: 1.6...5 mm (0.06...0.2 in)*3
Weight	0.4 kg (0.88 lb) or less	0.8 kg (1.76 lb) or less	1.3 kg (2.87 lb) or less

	STW-6600WA	STW-6700WA
Grounding	Functional grounding: Grounding resistance of 100 Ω or less, 2 mm ² (AWG 14) or thicker wire, or your country's applicable standard.	
Cooling method	Natural air circulation	
Structure*1	IP65F, Type 1, Type 4X (indoor use only), Type 13 (on the front panel when properly installed in an enclosure)	
External dimensions (W x H x D)	313 x 235 x 50 mm (12.32 x 9.25 x 1.97 in)	412 x 268 x 50 mm (16.22 x 10.55 x 1.97 in)
Panel cut dimensions (W x H)	295 x 217 mm (11.61 x 8.54 in)*2 Panel thickness area: 1.6...5 mm (0.06...0.2 in)*3	394 x 250 mm (15.51 x 9.84 in)*2 Panel thickness area: 1.6...5 mm (0.06...0.2 in)*3
Weight	1.8 kg (3.97 lb) or less	2.7 kg (5.95 lb) or less

*1 The front face of this product, installed in a solid panel, has been tested using conditions equivalent to the standards shown in the specification. Even though this product's level of resistance is equivalent to these standards, oils that should have no effect on this product can possibly harm this product. This can occur in areas where either vaporized oils are present, or where low viscosity cutting oils are allowed to adhere to this product for long periods of time. If this product's front face protection sheet or cover glass peels off, these conditions can lead to the ingress of oil into this product and separate protection measures are suggested. Also, if non-approved oils are present, they may cause deformation or corrosion of the front panel's cover. Therefore, prior to installing this product, be sure to confirm the type of conditions that will be present in this product's operating environment.

If the installation gasket is used for a long period of time, or if this product and its gasket are removed from the panel, the original level of protection cannot be kept. To maintain the original protection level, be sure to replace the installation gasket regularly.

*2 For dimensional tolerance, everything +1/-0 mm (+0.04/-0 in) and R in angle are below R3 (R0.12 in).

*3 Even if the installation wall thickness is within the recommended range for the Panel Cut Dimensions, depending on the wall's material, size, and installation location of this product and other devices, the installation wall could warp. To prevent warping, the installation surface may need to be strengthened.

NOTICE**EQUIPMENT DAMAGE**

- Ensure this product is not in permanent and direct contact with oils.
- Do not press on the display of this product with excessive force or with a hard object.
- Do not press on the touch panel with a pointed object, such as the tip of a mechanical pencil or a screwdriver.
- Do not expose the product to direct sunlight.

Failure to follow these instructions can result in equipment damage.

NOTICE**STORAGE AND OPERATION OUTSIDE OF SPECIFICATIONS**

- Store the panel in areas where temperatures are within the product's specifications.
- Do not restrict or block this panel's ventilation slots.

Failure to follow these instructions can result in equipment damage.

NOTICE**GASKET AGING**

- Inspect the gasket periodically as required by your operating environment.
- Change the gasket at least once a year, or as soon as scratches or dirt become visible.

Failure to follow these instructions can result in equipment damage.

Functional Specifications

Display Specifications

	STW-6200WA	STW-6400WA	STW-6500WA
Display type	TFT Color LCD		
Display size	4.3" wide	7" wide	10.1" wide
Resolution	480 x 272 pixels	800 x 480 pixels (WVGA)	1,024 x 600 pixels (WSVGA)
Effective display area (W x H)	95.04 x 53.86 mm (3.74 x 2.12 in)	154.08 x 85.92 mm (6.07 x 3.38 in)	222.72 x 125.28 mm (8.77 x 4.93 in)
Display colors	16 million colors		
Backlight	White LED (Not replaceable. Please contact customer support.)		
Backlight service life	50,000 hours or more (continuous operation at 25 °C [77 °F] before backlight brightness decreases to 25%)		
Brightness control	16 levels		

	STW-6600WA	STW-6700WA
Display type	TFT Color LCD	
Display size	12.1" wide	15.6" wide
Resolution	1,280 x 800 pixels (WXGA)	1,366 x 768 pixels (FWXGA)

	STW-6600WA	STW-6700WA
Effective display area (W x H)	261.12 x 163.2 mm (10.28 x 6.43 in)	344.23 x 193.54 mm (13.55 x 7.62 in)
Display colors	16 million colors	
Backlight	White LED (Not replaceable. Please contact customer support.)	
Backlight service life	50,000 hours or more (continuous operation at 25 °C [77 °F] before backlight brightness decreases to 25%)	
Brightness control	16 levels	

Touch Panel

Touch panel type	Resistive film (analog)
Touch points	Single touch
Touch panel resolution	1,024 x 1,024
Touch panel service life	1 million times or more

The touch panel does not support two point touch (multiple point touch). If you touch multiple points on the touch panel, it will operate as if you touched the center-point of the multiple touches.

For example, if you touch two or more points on the touch panel and at the center of the touches is a switch for a drive system, even though you did not directly touch that switch, it may function as if you did.

▲ WARNING
UNINTENDED EQUIPMENT OPERATION
Do not touch two or more points on the touch panel.
Failure to follow these instructions can result in death, serious injury, or equipment damage.

Memory

System memory	Flash EPROM 512 MB (operating system, web browser, and other data)
Backup memory	NVRAM 128 KB (configuration data)

Clock

This product does not have a real-time clock or battery to back up the clock.

Interface Specifications

Specifications of Each Interface

Use only the SELV (Safety Extra-Low Voltage) circuit to connect the USB and Ethernet interfaces.

	STW-6200WA	STW-64/65/66/6700WA
USB (Type A) interface		
Connector	USB 2.0 (Type A) x 1	
Power supply voltage	5 Vdc \pm 5%	
Maximum current supplied	500 mA	
Maximum transmission distance	5 m (16.4 ft)	
Ethernet interface		
Standard	IEEE802.3i/IEEE802.3u, 10BASE-T/100BASE-TX	
Connector	Modular jack (RJ-45) x 1	Modular jack (RJ-45) x 2

Dimensions

What's in This Chapter

STW-6200WA.....	27
STW-6400WA.....	29
STW-6500WA.....	30
STW-6600WA.....	32
STW-6700WA.....	33

STW-6200WA

External Dimensions

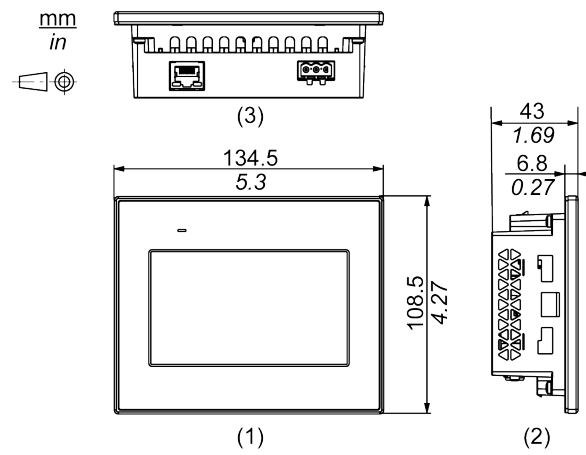

- 1 Front
- 2 Left
- 3 Bottom

Dimensions with Installation Fasteners

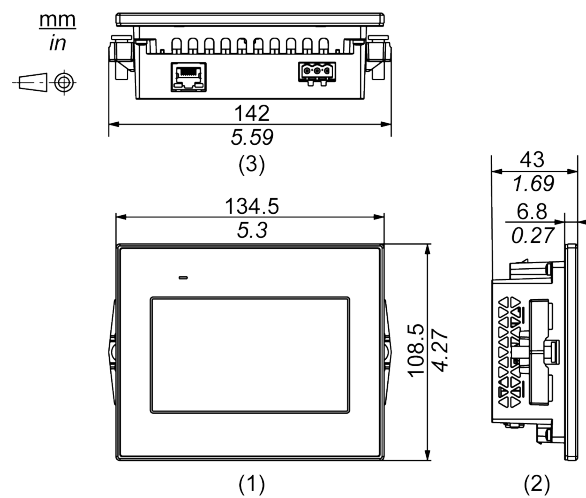

- 1 Front
- 2 Left
- 3 Bottom

Dimensions with Spring Clips

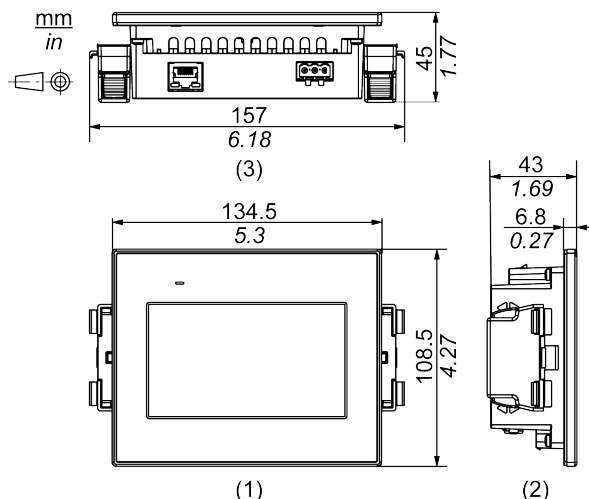

- 1 Front
- 2 Left
- 3 Bottom

Dimensions with Cables

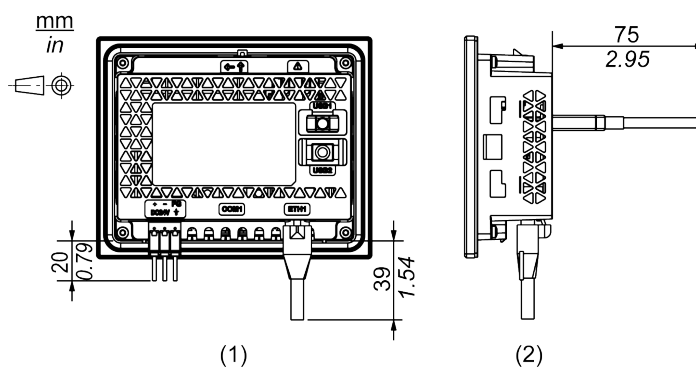

- 1 Rear
- 2 Right

NOTE: All the above values are designed with cable bending in mind. The dimensions given here are representative values depending on the type of connection cable in use. Therefore, these values are intended for reference only.

STW-6400WA

External Dimensions

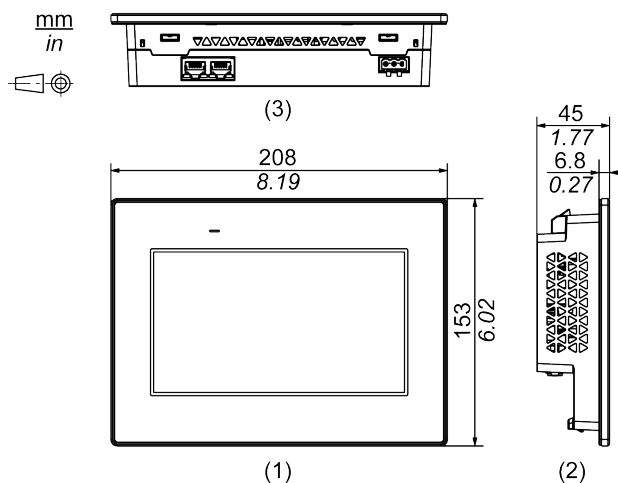

- 1 Front
- 2 Left
- 3 Bottom

Dimensions with Installation Fasteners

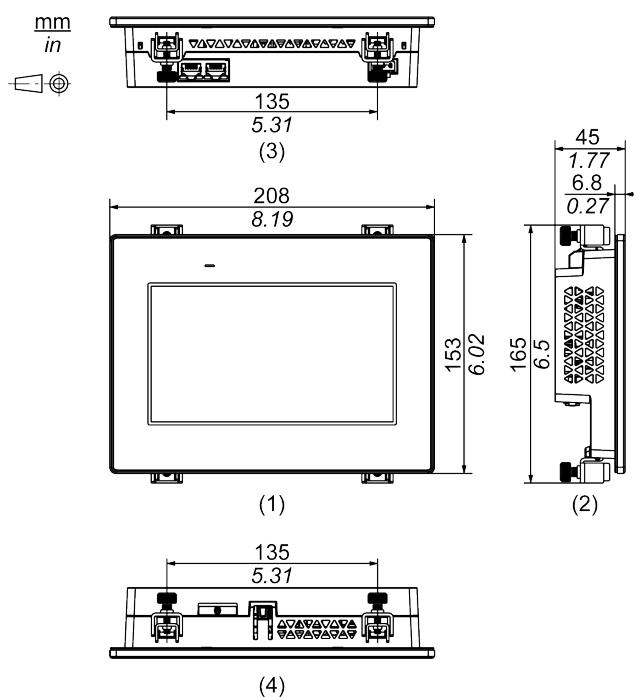

- 1 Front
- 2 Left
- 3 Bottom
- 4 Top

Dimensions with Cables

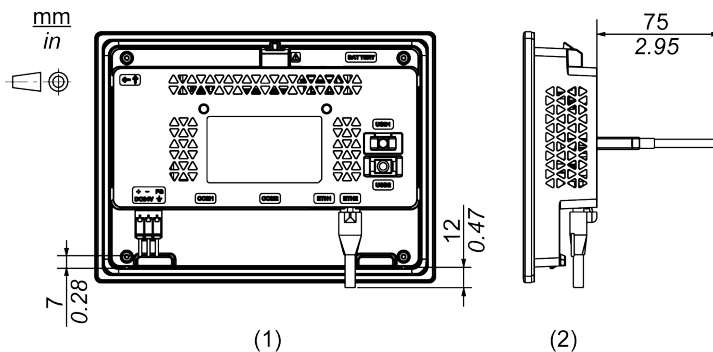

1 Rear

2 Right

NOTE: All the above values are designed with cable bending in mind. The dimensions given here are representative values depending on the type of connection cable in use. Therefore, these values are intended for reference only.

STW-6500WA

External Dimensions

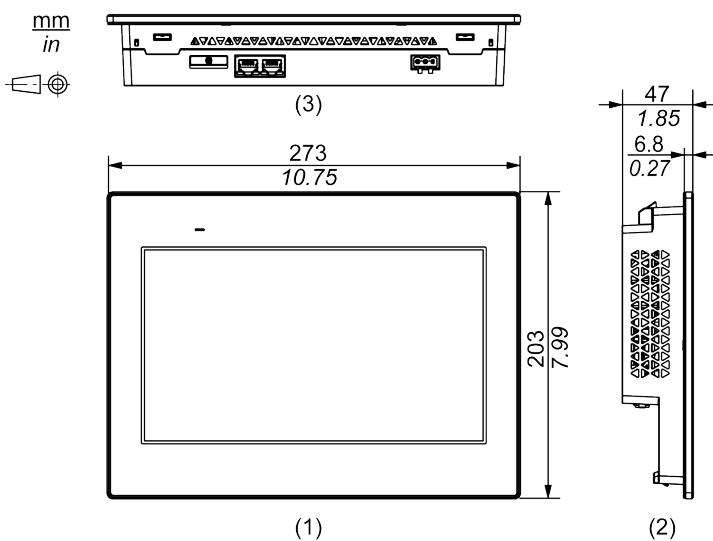

1 Front

2 Left

3 Bottom

Dimensions with Installation Fasteners

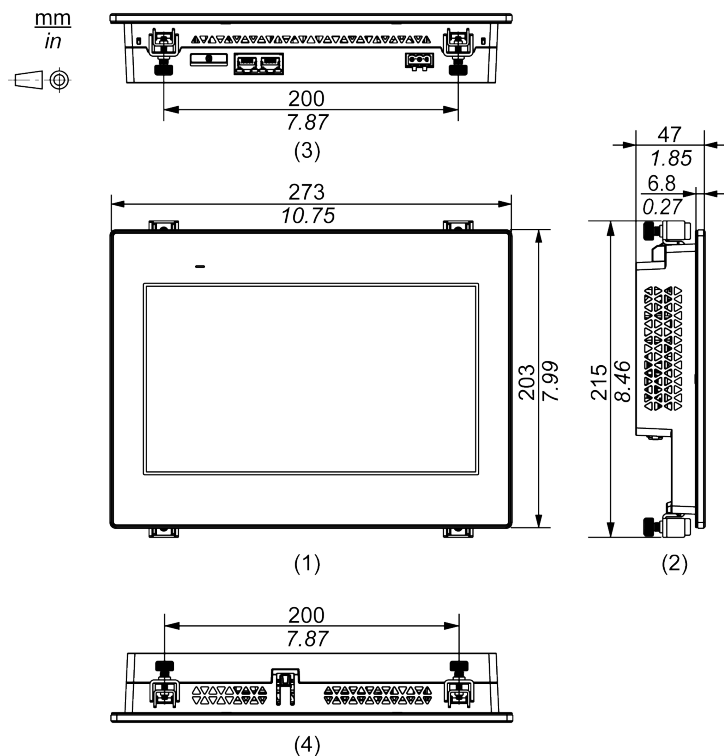

- 1 Front
- 2 Left
- 3 Bottom
- 4 Top

Dimensions with Cables

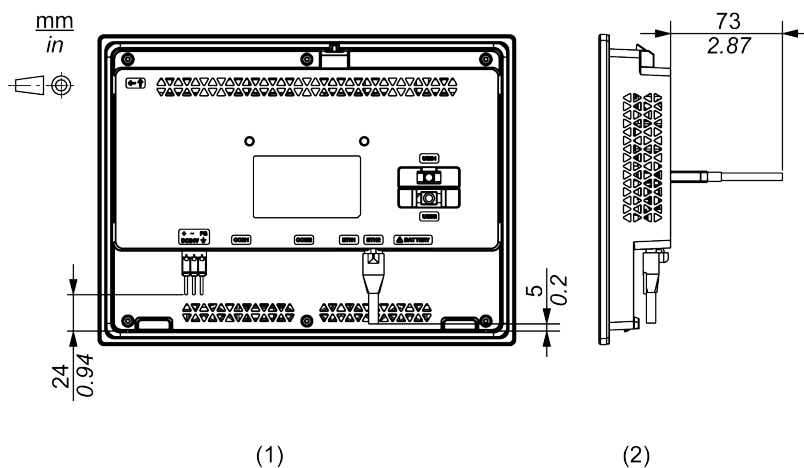

- 1 Rear
- 2 Right

NOTE: All the above values are designed with cable bending in mind. The dimensions given here are representative values depending on the type of connection cable in use. Therefore, these values are intended for reference only.

STW-6600WA

External Dimensions

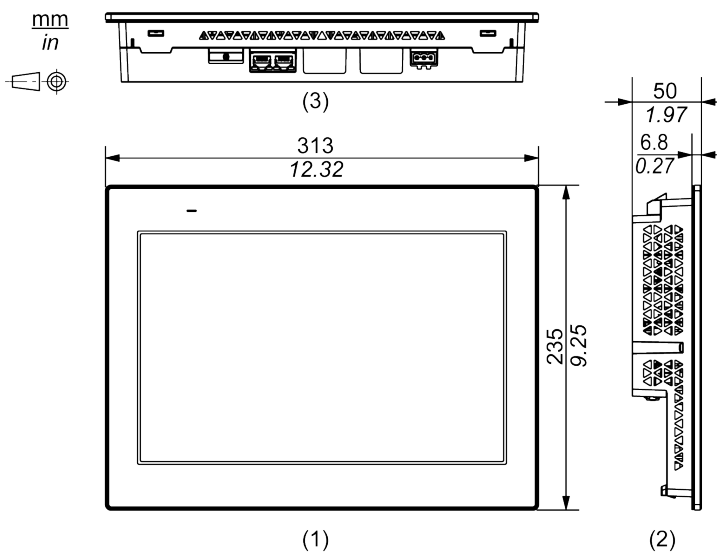

- 1 Front
- 2 Left
- 3 Bottom

Dimensions with Installation Fasteners

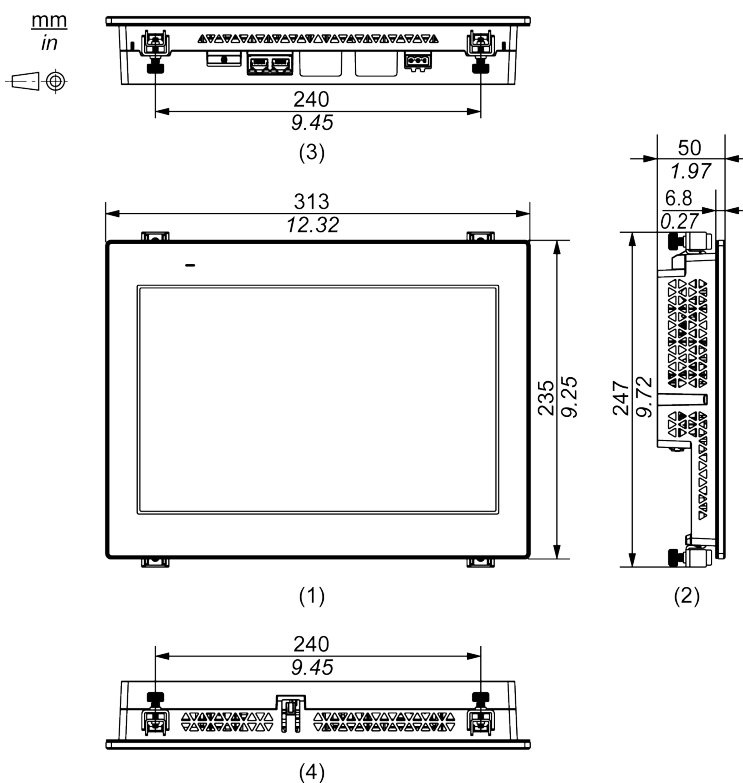

- 1 Front
- 2 Left
- 3 Bottom

4 Top

Dimensions with Cables

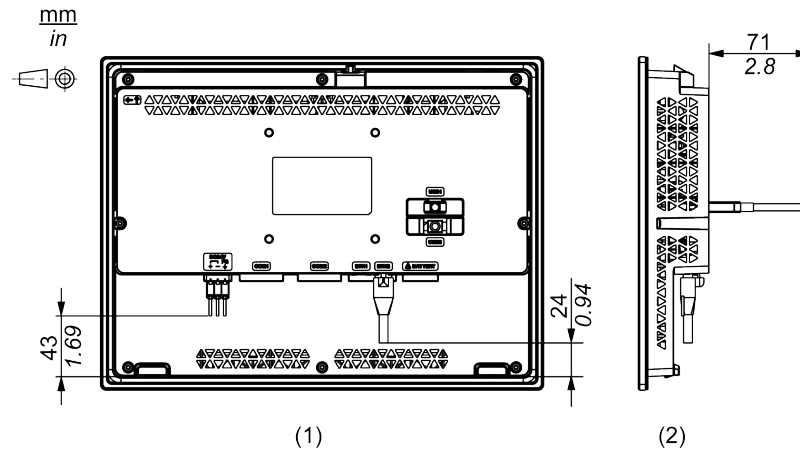

1 Rear

2 Right

NOTE: All the above values are designed with cable bending in mind. The dimensions given here are representative values depending on the type of connection cable in use. Therefore, these values are intended for reference only.

STW-6700WA

External Dimensions

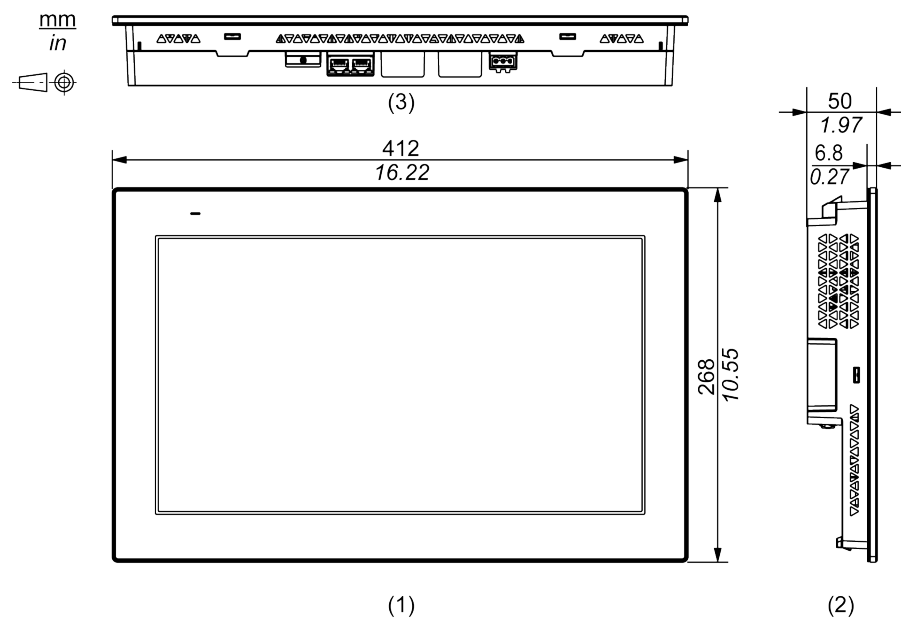

1 Front

2 Left

3 Bottom

Dimensions with Installation Fasteners

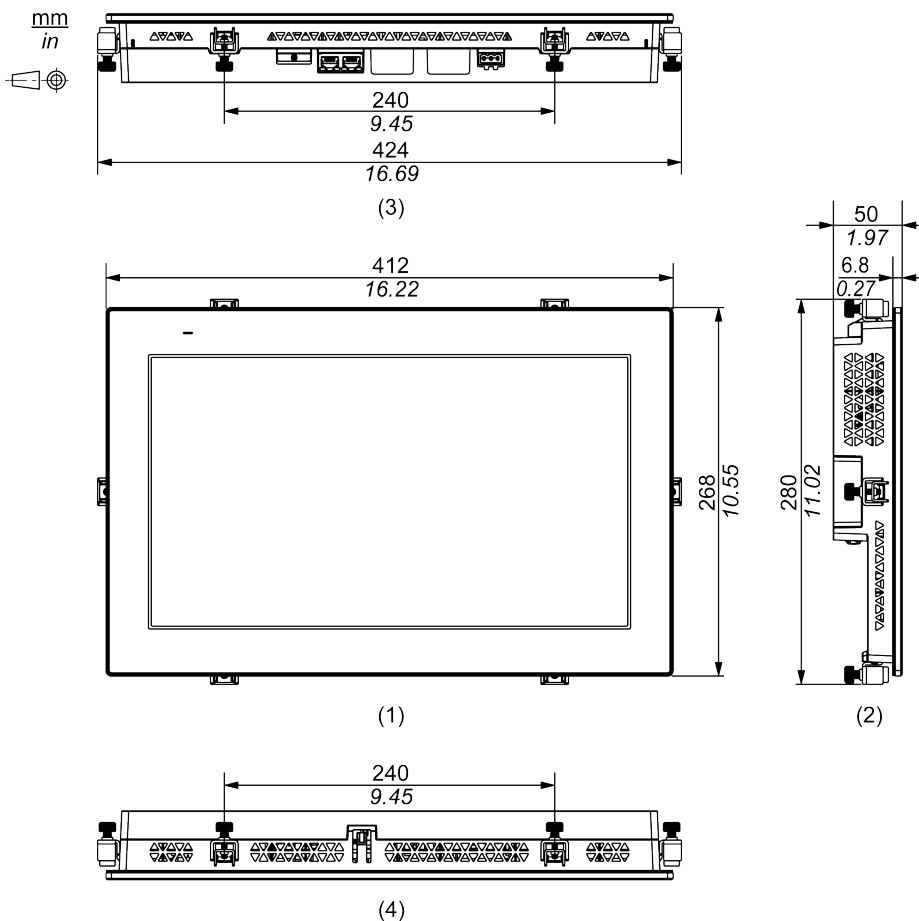

- 1 Front
- 2 Left
- 3 Bottom
- 4 Top

Dimensions with Cables

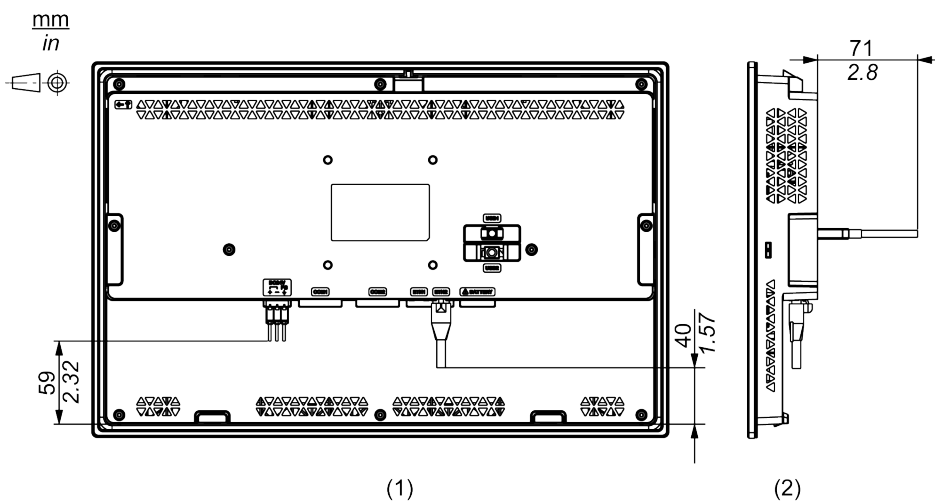

- 1 Rear
- 2 Right

NOTE: All the above values are designed with cable bending in mind. The dimensions given here are representative values depending on the type of connection cable in use. Therefore, these values are intended for reference only.

Installation and Wiring

What's in This Chapter

Installation	36
Wiring the Power Supply	46
USB Cable Clamp	50

Installation

Precautions for Building into an End-use Product

This product is designed for use on flat surfaces of IP65F, Type 1, Type 4X (indoor use only) and Type 13 enclosures.

Be aware of the following when building this product into an end-use product:

- The rear face of this product is not approved as an enclosure. When building this product into an end-use product, be sure to use an enclosure that satisfies standards as the end-use product's overall enclosure.
- Install this product in an enclosure with mechanical rigidity.
- This product is not designed for outdoor use. UL certification obtained is for indoor use only.
- Install and operate this product with its front panel facing outward.

NOTE:

- The necessary torque is 0.5 N•m (4.4 lb-in).
- IP65F is not part of the UL certification.

Installation Requirements

▲ CAUTION

RISK OF BURNING INJURY

Do not touch the bezel or rear chassis during operation.

Failure to follow these instructions can result in injury or equipment damage.

- Check that the installation wall or cabinet surface is flat, in good condition and has no jagged edges. Metal reinforcing strips may be attached to the inside of the wall, near the panel-cut, to increase its rigidity.
- Decide on the thickness of the enclosure wall, based on the level of strength required. Even if the installation wall thickness is within the recommended range for the Panel Cut Dimensions, depending on the wall's material, size, and installation location of this product and other devices, the installation wall could warp. To prevent warping, the installation surface may need to be strengthened.

- Check that the ambient air temperature and the ambient humidity are within their specified ranges in *Environmental Specifications*, page 22. When installing this product in a cabinet or enclosure, the ambient air temperature is the cabinet's or enclosure's internal and external temperature.

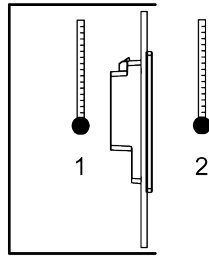

1. Internal temperature
2. External temperature

- Be sure that heat from surrounding equipment does not cause this product to exceed its standard operating temperature.
- When installing this product in a slanted position, the product face should not incline more than 30°.

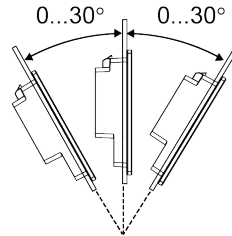

- For easier maintenance, operation and improved ventilation, install this product at least 100 mm (3.94 in) away from adjacent structures and other equipment as shown in the following illustration:

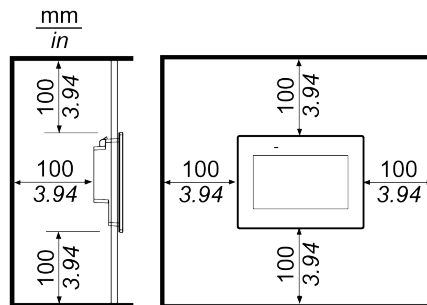

NOTE: This product does not support portrait installation.

Pressure Differences

When applying and installing this product, it is important that steps are taken to eliminate any pressure difference between the inside and the outside of the enclosure in which this product is mounted. Higher pressure inside the enclosure can cause delamination of the front membrane of the display. Even a small pressure difference inside the enclosure will act on the large area of the membrane and can result in sufficient force to delaminate the membrane and thus cause failure of the touch capability. Pressure differences can often occur in applications where there are multiple fans and ventilators moving air at different rates in different rooms. Please follow these techniques to ensure that this product's function is not impacted by this mis-application:

1. Seal all conduit connections inside of the enclosure, especially those that lead to other rooms that may be at a different pressure.
2. Where applicable, install a small weep hole at the bottom of the enclosure to allow equalization of the internal and external pressure.

Panel Cut Dimensions

Based on the panel cut dimensions, open a mount hole on the panel.

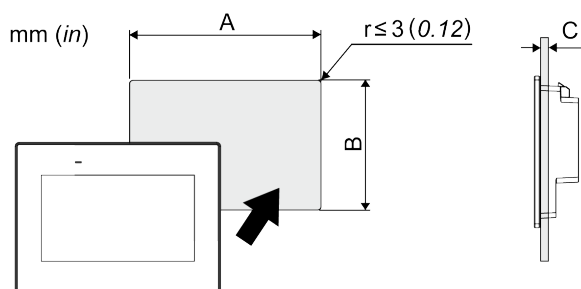

Model name		
A	B	C*1
STW-6200WA		
118.5 mm (+1/-0 mm) (4.67 in [+0.04/-0 in])	92.5 mm (+1/-0 mm) (3.64 in [+0.04/-0 in])	1.6...5 mm (0.06...0.2 in)
STW-6400WA		
190 mm (+1/-0 mm) (7.48 in [+0.04/-0 in])	135 mm (+1/-0 mm) (5.31 in [+0.04/-0 in])	1.6...5 mm (0.06...0.2 in)
STW-6500WA		
255 mm (+1/-0 mm) (10.04 in [+0.04/-0 in])	185 mm (+1/-0 mm) (7.28 in [+0.04/-0 in])	1.6...5 mm (0.06...0.2 in)
STW-6600WA		
295 mm (+1/-0 mm) (11.61 in [+0.04/-0 in])	217 mm (+1/-0 mm) (8.54 in [+0.04/-0 in])	1.6...5 mm (0.06...0.2 in)
STW-6700WA		
394 mm (+1/-0 mm) (15.51 in [+0.04/-0 in])	250 mm (+1/-0 mm) (9.84 in [+0.04/-0 in])	1.6...5 mm (0.06...0.2 in)

*1 When installing STW-6200WA with spring clips:

- Position 1: 1.5...4 mm (0.06...0.16 in)
- Position 2: 4...6 mm (0.16...0.24 in)

NOTE: For the positions, refer to the Installation Procedure (STW-6200WA), page 39.

Installation Procedure (STW-6200WA)

Installing Using Installation Fasteners

⚠️ DANGER

HAZARD OF ELECTRIC SHOCK, EXPLOSION, OR ARC FLASH

- Remove all power from the device before removing any covers or elements of the system, and prior to installing or removing any accessories, hardware, or cables.
- Unplug the power cable from both this product and the power supply prior to installing or removing the product.
- Always use a properly rated voltage sensing device to confirm power is off where and when indicated.
- Replace and secure all covers or elements of the system before applying power to this product.

Failure to follow these instructions will result in death or serious injury.

NOTICE

EQUIPMENT DAMAGE

- Always use the installation gasket.
- Keep this product stabilized in the panel-cut while you are installing or removing the fasteners.

Failure to follow these instructions can result in equipment damage.

1. Place this product on a clean and level surface with the screen facing down.
2. Check that this product's gasket is seated securely into the bezel's groove, which runs around the perimeter of the display panel frame.

NOTE: Always use the installation gasket, since it absorbs vibration in addition to repelling water. For the procedure on replacing the installation gasket, refer to *Replacing the Installation Gasket*, page 66.

3. Based on this product's *Panel Cut Dimensions*, page 38, open a mount-hole on the panel and attach this product to the panel from the front side.

NOTE: This product has a hook at the top to prevent it from falling. Insert the bottom part of the product into the panel opening, and then insert the top part while pushing the hook down.

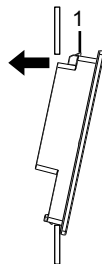

1 Hook

4. Insert the installation fastener hooks into the insertion slots of this product.

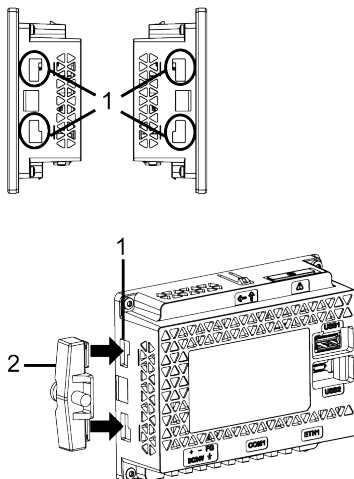

1 Insertion slots

2 Installation fastener

5. In a clockwise direction, tighten the installation fastener's screws with a screwdriver. The necessary torque is 0.5 N•m (4.4 lb-in).

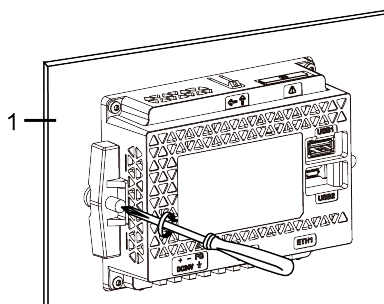

1 Installation panel

NOTICE

BROKEN ENCLOSURE

Do not exert more torque than the amount specified.

Failure to follow these instructions can result in equipment damage.

Installing Using Spring Clips

⚡ ⚠ DANGER

HAZARD OF ELECTRIC SHOCK, EXPLOSION, OR ARC FLASH

- Remove all power from the device before removing any covers or elements of the system, and prior to installing or removing any accessories, hardware, or cables.
- Unplug the power cable from both this product and the power supply prior to installing or removing the product.
- Always use a properly rated voltage sensing device to confirm power is off where and when indicated.
- Replace and secure all covers or elements of the system before applying power to this product.

Failure to follow these instructions will result in death or serious injury.

⚠ CAUTION**SPRING LOADED MECHANISM**

Do not release the spring clip mechanism near your face.

Failure to follow these instructions can result in injury or equipment damage.

NOTICE**EQUIPMENT DAMAGE**

- Always use the installation gasket.
- Keep this product stabilized in the panel-cut while you are installing or removing the fasteners.

Failure to follow these instructions can result in equipment damage.

1. Place this product on a clean and level surface with the screen facing down.
2. Check that this product's gasket is seated securely into the bezel's groove, which runs around the perimeter of the display frame.

NOTE: Always use the installation gasket, since it absorbs vibration in addition to repelling water. For the procedure on replacing the installation gasket, refer to [Replacing the Installation Gasket](#), page 66.

3. Based on this product's [Panel Cut Dimensions](#), page 38, open a mount hole on the panel and attach this product to the panel from the front side.

NOTE: This product has a hook at the top to prevent it from falling. Insert the bottom part of the product into the panel opening, and then insert the top part while pushing the hook down.

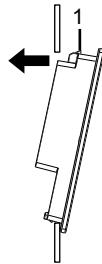

1 Hook

4. Press the spring clip hooks into the insertion slots on this product. Adjust the spring clips for the panel thickness by turning it over:
 - Position 1
1.5 mm (0.059 in) ≤ panel thickness ≤ 4 mm (0.157 in).
 - Position 2
4 mm (0.157 in) ≤ panel thickness ≤ 6 mm (0.236 in).

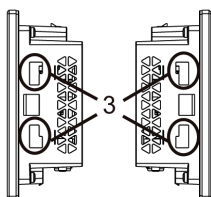
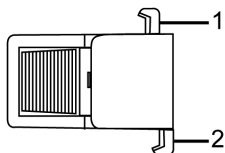

Side of the spring clip

- 1 Hook for position 1
- 2 Hook for position 2
- 3 Insertion slots

5. Lock the spring clips by simultaneously pressing the top and bottom of the clip.

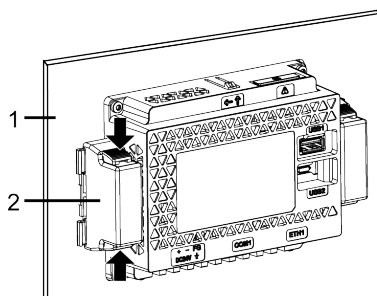

- 1 Installation panel
- 2 Spring clip

6. To remove the spring clips, unlock the clips by pressing on the back of the clip until you hear a click.

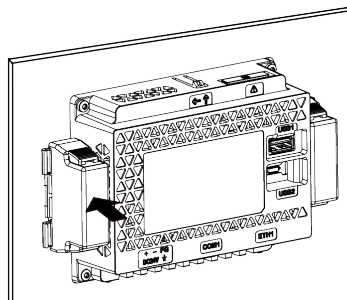

⚠ CAUTION**RISK OF INJURY**

Do not drop this product when you remove it from the panel.

- Hold this product in place after removing the spring clips.
- Use both hands.
- While pushing on the hook, be careful not to hurt your fingers.

Failure to follow these instructions can result in injury or equipment damage.

Installation Procedure (STW-64/65/66/6700WA)**Installing Using Installation Fasteners****⚠⚠ DANGER****HAZARD OF ELECTRIC SHOCK, EXPLOSION, OR ARC FLASH**

- Remove all power from the device before removing any covers or elements of the system, and prior to installing or removing any accessories, hardware, or cables.
- Unplug the power cable from both this product and the power supply prior to installing or removing the product.
- Always use a properly rated voltage sensing device to confirm power is off where and when indicated.
- Replace and secure all covers or elements of the system before applying power to this product.

Failure to follow these instructions will result in death or serious injury.

NOTICE**EQUIPMENT DAMAGE**

- Always use the installation gasket.
- Keep this product stabilized in the panel-cut while you are installing or removing the fasteners.

Failure to follow these instructions can result in equipment damage.

1. Place this product on a clean and level surface with the screen facing down.
2. Check that this product's gasket is seated securely into the bezel's groove, which runs around the perimeter of the display panel frame.

NOTE: Always use the installation gasket, since it absorbs vibration in addition to repelling water. For the procedure on replacing the installation gasket, refer to Replacing the Installation Gasket, page 66.

3. Based on this product's Panel Cut Dimensions, page 38, open a mount-hole on the panel and attach this product to the panel from the front side.

NOTE: This product has a hook at the top to prevent it from falling. Insert the bottom part of the product into the panel opening, and then insert the top part while pushing the hook down.

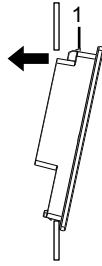

1 Hook

4. Insert the installation fastener hooks into the insertion slots of this product.

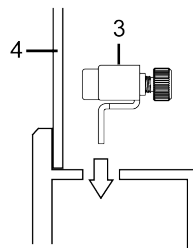
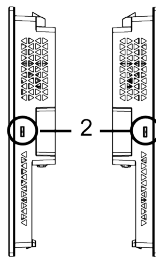
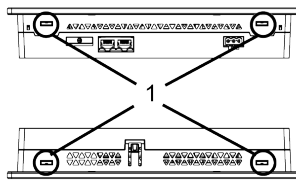

1 Insertion slots

2 Insertion slots (STW-6700WA only)

3 Installation fastener

4 Installation panel

- In a clockwise direction, tighten the installation fastener's screws with a screwdriver. The necessary torque is 0.5 N•m (4.4 lb-in).

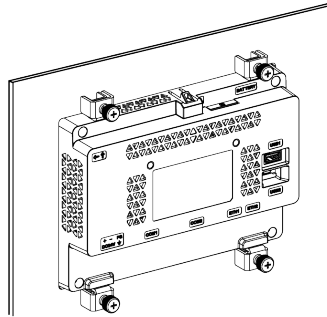
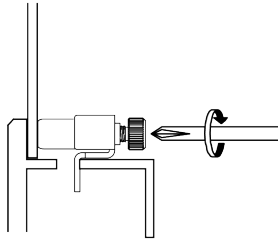

NOTE: The installation fasteners can be screwed by hand too.

NOTICE

BROKEN ENCLOSURE

Do not exert more torque than the amount specified.

Failure to follow these instructions can result in equipment damage.

Removal Procedure

⚠️⚠️ DANGER

HAZARD OF ELECTRIC SHOCK, EXPLOSION, OR ARC FLASH

- Remove all power from the device before removing any covers or elements of the system, and prior to installing or removing any accessories, hardware, or cables.
- Unplug the power cable from both this product and the power supply prior to installing or removing the product.
- Always use a properly rated voltage sensing device to confirm power is off where and when indicated.

Failure to follow these instructions will result in death or serious injury.

⚠️ CAUTION

RISK OF INJURY

Do not drop this product when you remove it from the panel.

- Hold this product in place after removing the fasteners.
- Use both hands.
- While pushing on the hook, be careful not to hurt your fingers.

Failure to follow these instructions can result in injury or equipment damage.

NOTICE

EQUIPMENT DAMAGE

- Keep this product stabilized in the panel-cut while you are installing or removing the screw fasteners.
- To avoid damage, remove this product while pushing the hook or by making sure the lock does not touch the panel.

Failure to follow these instructions can result in equipment damage.

1. Loosen the screws of the installation fasteners and remove them.
2. While pushing the hook on the top of this product, slowly remove this product from the panel.



1 Hook

Wiring the Power Supply

Connecting the DC Power Cord

⚡ ⚠ DANGER

HAZARD OF ELECTRIC SHOCK, EXPLOSION, OR ARC FLASH

- Remove all power from the device before removing any covers or elements of the system, and prior to installing or removing any accessories, hardware, or cables.
- Remove power before wiring this product's power terminals.
- Always use a properly rated voltage sensing device to confirm power is off.
- Replace and secure all covers or elements of the system before applying power to this product.
- Use only the specified voltage when operating this product. This product is designed to use 24 Vdc. Always check whether your device is DC powered before applying power.
- Since this product is not equipped with a power switch, be sure to connect a power switch to the power supply.
- Be sure to ground this product's FG terminal.

Failure to follow these instructions will result in death or serious injury.

NOTE:

- The SG (signal ground) and FG (functional ground) terminals are separated inside this product.
- When the FG terminal is connected, be sure the wire is grounded. Not grounding this product can result in excessive electromagnetic interference (EMI).

DC Power Cord Preparation

- Make sure the ground wire is either the same or heavier gauge than the power wires.
- Do not use aluminum wires in the power supply's power cord.
- If the ends of the individual wires are not twisted correctly, the wires may create a short circuit. When inserting a wire into the connector, hold down the opening button and insert the wire while the internal spring is depressed. Alternatively, you can crimp and insert either a pin terminal or ferrule terminal.
- The conductor type is solid or stranded wire.
- Use copper wire rated for 75 °C (167 °F) or higher.
- Use the SELV (Safety Extra-Low Voltage) circuit and LIM (Limited Energy) circuit for DC input.

Power cord diameter	0.75...2.5 mm ² (18...13 AWG)*1
Conductor type	Solid or stranded wire
Conductor length	
Recommended driver	Flat-head screwdriver (size 0.6 x 3.5 mm)

*1 For UL compatibility, use AWG 14 or AWG 13.

DC Power Supply Connector Specifications

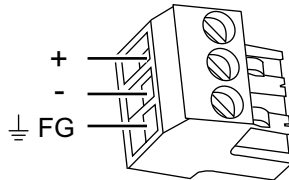

+	24 Vdc
-	0 Vdc
FG	Functional ground (Connect the FG terminal properly to ground.)

NOTE: Model number: CA5-DCCNM-01 (or MSTB2,5/3-ST-5,08 by Phoenix Contact)

How to connect the DC Power Cord

Step	Action
1	Confirm the power cord is not connected to the power supply.
2	Check the rated voltage.
3	Remove the DC power supply connector from this product.
4	Strip the membrane of the power cord, and twist the wire ends.

Step	Action
5	<p>Insert each power cord wire into its corresponding hole. Fasten the screws of the DC power supply connector to clamp the wire in place.</p> <p>NOTE:</p> <ul style="list-style-type: none"> The necessary torque is 0.56 N•m (5 lb-in). Do not solder the cable connection.
6	After inserting all three power cord wires, insert the DC power supply connector into the power connector on this product.

Power Supply Precautions

⚠ DANGER

SHORT CIRCUIT, FIRE, OR UNINTENDED EQUIPMENT OPERATION

- Install and fasten this product in an installation panel or cabinet prior to connecting power supply and communication lines.
- Securely attach power cables to an installation panel or cabinet.
- Avoid excessive force on the power cable.

Failure to follow these instructions will result in death or serious injury.

- This product's power cord should not be bundled with or kept close to main circuit lines (high voltage, high current), power lines, or input/output lines, and their various systems should be kept separate. When power lines cannot be wired via a separate system, use shielded cables for input/output lines.
- An independent DC power supply is recommended for this product. (The DC power supply should be located close to the product, with twisted pair cabling as short as possible.)
- To increase noise resistance, attach a ferrite core to the power cable.

Power Supply Connections

- Use the SELV (Safety Extra-Low Voltage) circuit and LIM (Limited Energy) circuit for DC input.
- If the voltage variation is outside the prescribed range, connect a regulated power supply.

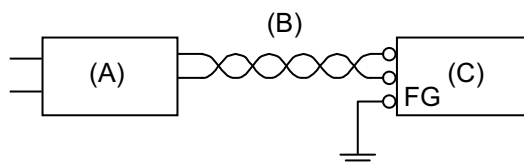

- A. Regulated power supply
- B. Twisted-pair cord
- C. This product

Grounding

Independent Grounding

Always ground the FG (functional ground) terminal. Be sure to separate this product from the FG of other devices as shown below.

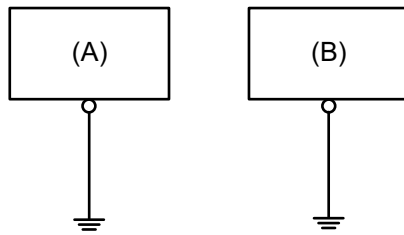

- A. This product
- B. Other device

Precautions

- Check that the grounding resistance is 100 Ω or less.*1
- The FG wire should have a cross sectional area 2 mm² (AWG14) or greater*1. Create the connection point as close as possible to this product, and make the wire as short as possible. When using a long grounding wire, replace the thin wire with a thicker wire, and place it in a duct.
- The SG and FG terminals are separated internally in the product. When connecting the FG and SG, be sure that no ground loop is formed.

*1 Observe local codes and standards.

Common Grounding

Electromagnetic Interference (EMI) can be created if devices are improperly grounded. EMI can cause loss of communication. If independent grounding is not possible, use a common grounding point as shown in the configuration below. Do not use any other configuration for common grounding.

Correct grounding

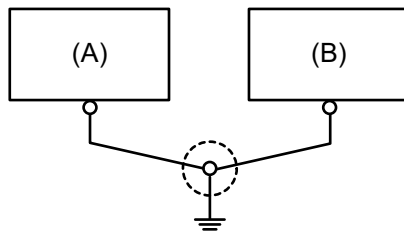

- A. This product
- B. Other device

Incorrect grounding

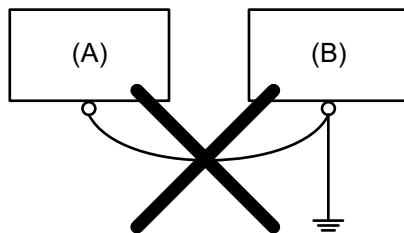

- A. This product
- B. Other device

USB Cable Clamp

USB Clamp Type A (1 port)

Introduction

When using a USB device, attach a USB cable clamp to the USB interface to prevent the USB cable from being disconnected.

⚠ DANGER

EXPLOSION HAZARD

- Do not disconnect equipment while the circuit is live or unless the area is known to be free of ignitable concentrations.
- Remove power before attaching or detaching any connectors to or from this product.
- Ensure that power, communication, and accessory connections do not place excessive stress on the ports. Consider the vibration in the environment when making this determination.
- Securely attach power, communication, and external accessory cables to the panel or cabinet.
- Use only commercially available USB cables.
- Use only non-incendive USB configurations.
- Do not use this product in hazardous environments.
- Confirm that the USB cable has been attached with the USB cable clamp before using the USB interface.

Failure to follow these instructions will result in death or serious injury.

Attaching USB Clamp Type A (1 port)

NOTE: Watch your fingers. The edge of the clip is sharp.

1. Mount the clip to the USB mark  connector shell so that it overlaps. The clip matches the 27 to 43.5 mm (1.06 to 1.71 in) length of the USB connector.

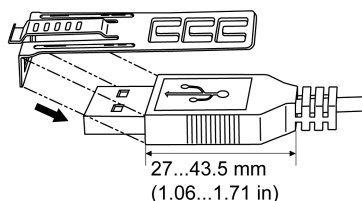

2. Align the clip and the USB cable connector shell. Adjust the position of the holes where the clip is attached. To ensure stability, select the clip-hole position that is closest to the base of the connector shell.

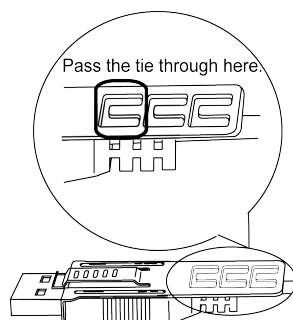

- As shown, pass the tie through the clip hole. Next, turn the tie and pass it through the head so that the USB cable can pass through the center of the tie loop. The clip is now attached to the USB cable.

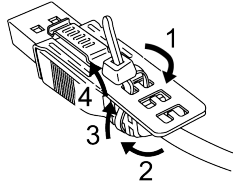

NOTE:

- Check the direction of the head beforehand. Make sure the USB cable is through the center of the tie loop and that the tie can pass through the head.
 - You can substitute the tie provided with PFXZCBCLUSA1 (by Pro-face), or other commercially available ties with a width of 4.8 mm (0.19 in) and thickness of 1.3 mm (0.05 in).
- While pressing the grip on the clip, insert the cable from step 3 all the way into the USB host interface. Make sure that the clip tab is secured to the USB cable attached to this product.

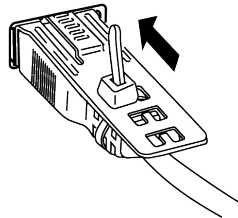

Removing USB Cable Clamp Type A (1 port)

Remove the USB cable while pushing the grip section of the clip.

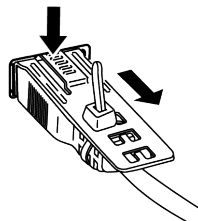

Display/Browser Settings

What's in This Chapter

Startup Settings	52
Update the System	54
Web Browser	55
Configuration Menu	57

Startup Settings

Settings Workflow

After turning on the product for the very first time, set up the display and Web Browser.

1. Connect this product to the Intranet.
2. Turn on the product.
3. The password input screen is displayed. Enter the default password **Admins** and touch **Login**.

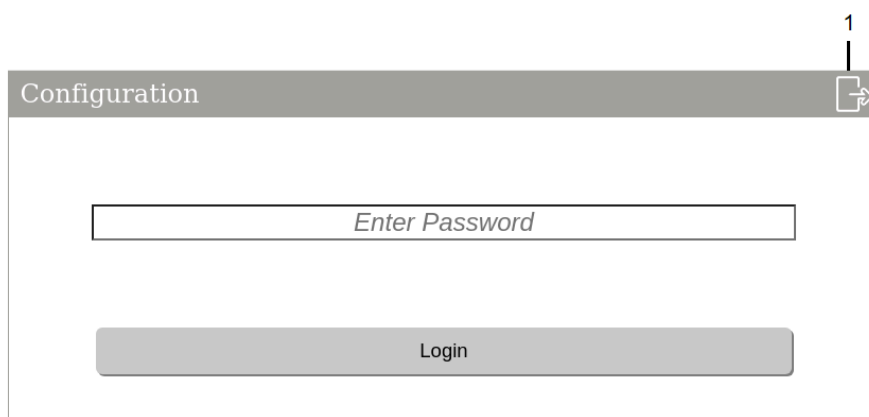

NOTE: Touching the button (1) will restart this product.

- The password change screen is displayed. Set a new password. Passwords must be at least 8 alphanumeric characters long and contain at least one uppercase letter, one lowercase letter, and one number.

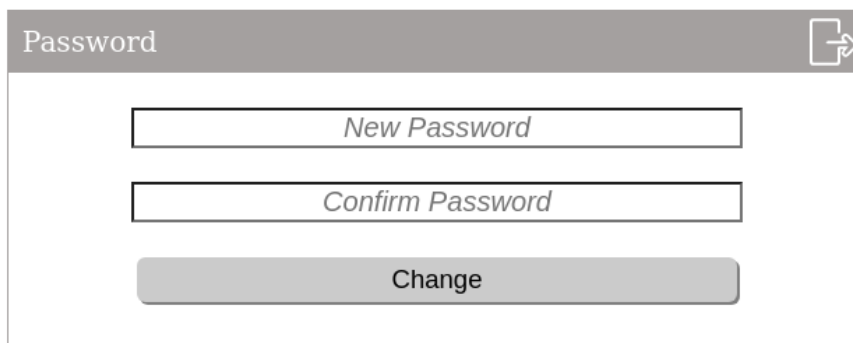

NOTE:

- Right after logging in with the default password, if the password change screen is not displayed, update the product with the latest available system. To update the system, refer to *Update the System*, page 54.
- Do not lose the password. If you have lost the password, please contact customer support.

- The Configuration Menu is displayed. Select **Network** to configure network settings such as the IP address and subnet mask for the product. Set to the same network as the Web server equipment on the Intranet.

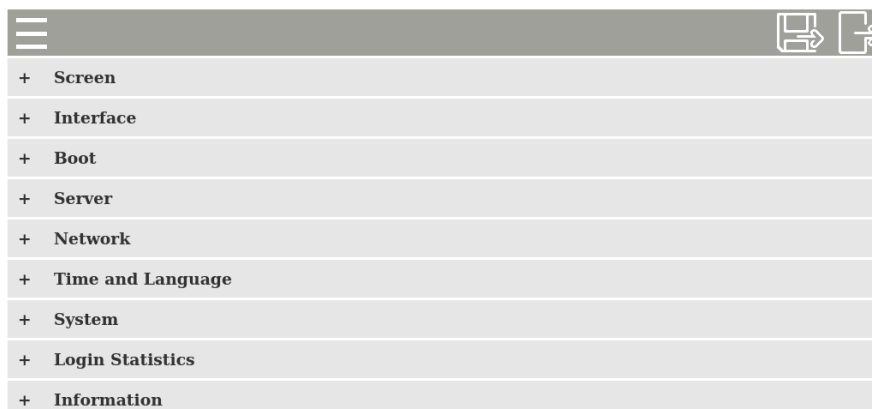

- From the Configuration Menu, select **Server** to register Web server devices connected to the same Intranet. You can also set a Web server that automatically displays as the start page at product startup.

NOTE: HTTPS communication is not supported.

- Additionally, set up various settings such as **Boot**, **Screen**, and so on from the Configuration Menu as required.
- Touch **Save & Reboot** to save the settings. The product is restarted.

If **Boot > Delay Time** is set, the following screen appears after the product starts up until the set time elapses.

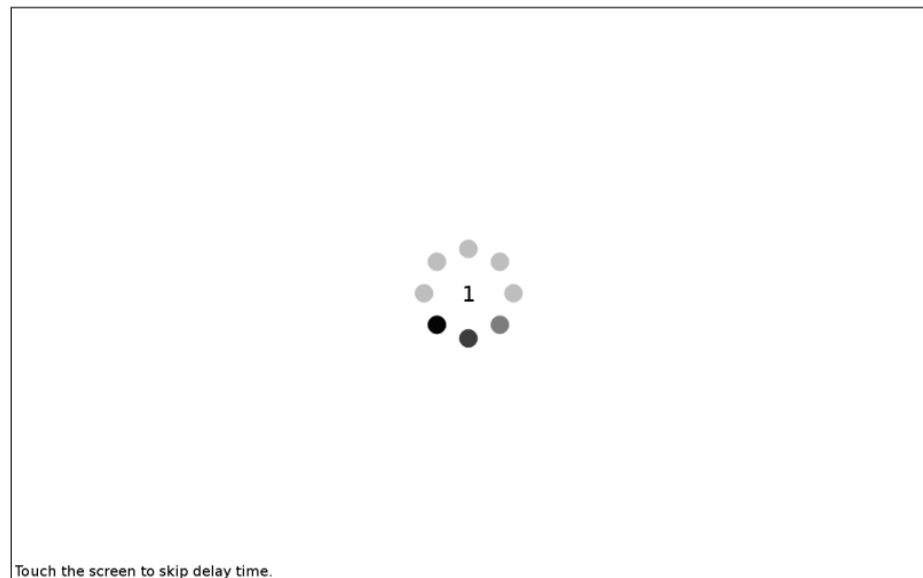

After the time set in **Delay Time** elapses, the screen specified in **Server > Start Page** is displayed.

If **Configuration** is selected as the **Start Page**, the password input screen appears after the product starts up. Enter the password and log in.

Update the System

Updates the product system with the system file saved on USB storage.

1. Prepare a USB storage device (formatted to FAT32).
2. Download the system update file for this product from our website.
<https://www.pro-face.com/trans/en/manual/1089.html>
3. Unzip the downloaded file and save all files to the root folder of the USB storage device.
4. Connect the USB storage device to the product and turn on the product.
5. Display the Configuration Menu. Refer to How to Display Configuration Menu, page 56.
6. Touch **System**, then under **Update System** touch the **Update** button. In the message that displays, touch **OK**.
7. The update process is started. Please wait a moment until the process is complete. When prompted to restart, touch **OK**.

- After restarting the product, verify that the system has been updated. Display the browser title bar and touch the Menu icon > Information icon, in that order.

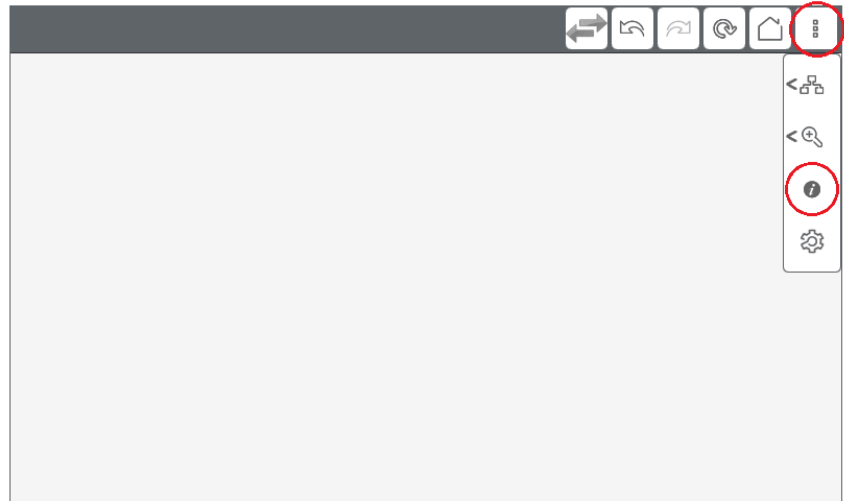

Web Browser

Operation of Web Browser

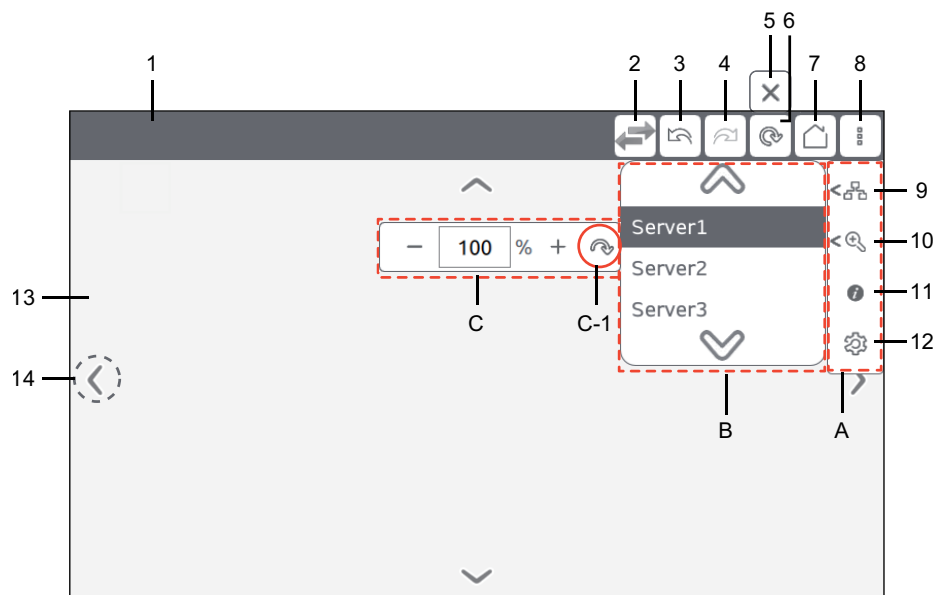

No.	Description
1	Displays the title of the Web server page or the URL when the page does not have a title.
2	Each time you touch this icon, the displayed Web server changes. NOTE: The server switching icon is available for products with system version V1.1.0 or later.
3	Moves to the previous page.
4	Moves to the next page.
5	Icon that displays while loading the Web server screen. Touch this icon to interrupt the load operation.

No.	Description
6	Reloads the Web server screen. Touch this icon and when the load operation starts, the icon changes to the No.5 icon.
7	Displays the Web server screen set in Server > Start Page .
8	Touch this icon to display the A sub menu.
9	Touch this icon to display the B sub menu, where you can select the Web server to display.
10	Touch this icon to display the C sub menu, where you can adjust the zoom level from 25 to 500%. The default setting is [100%]. C-1 is the reset button.
11	Displays the system version, network, current usage and license information.
12	Displays the Configuration Menu, page 57.
13	Displays the selected Web server screen.
14	Touch the screen to display these scroll buttons. You can hide these arrows with Boot > Hidden Scroll Arrow .

How to Display Configuration Menu

This product uses a dedicated web browser to display the screens of Web server devices on the Intranet.

While you are not working with the browser's icons, the title bar at the top of the screen is hidden.

1. From the top part of the screen, slowly swipe downward with force. The title bar of the browser appears.

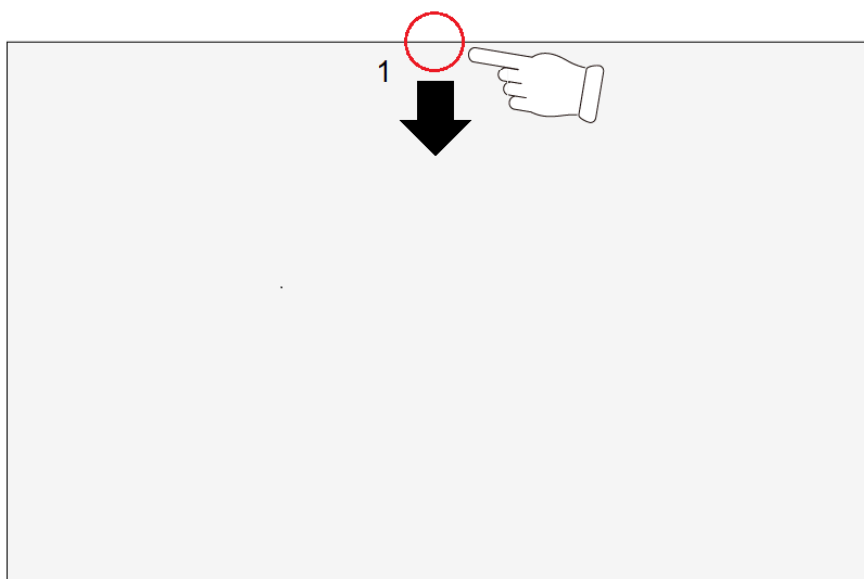

2. Touch the menu icon on the right side of the title bar.

3. Touch the configuration icon.

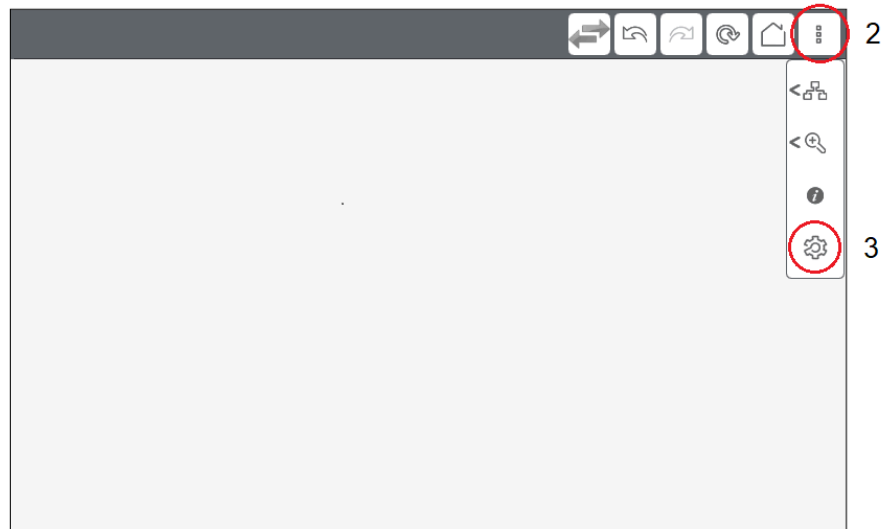

4. The password input screen appears. Enter the password to log in. The Configuration Menu displays.

Configuration Menu

Save and Exit

After changes in the Configuration Menu are complete, touch the **Save & Reboot** button. The settings are saved and the product restarts.

To exit (log out) without saving any changes to settings, touch **Exit without Saving**. The product will automatically restart.

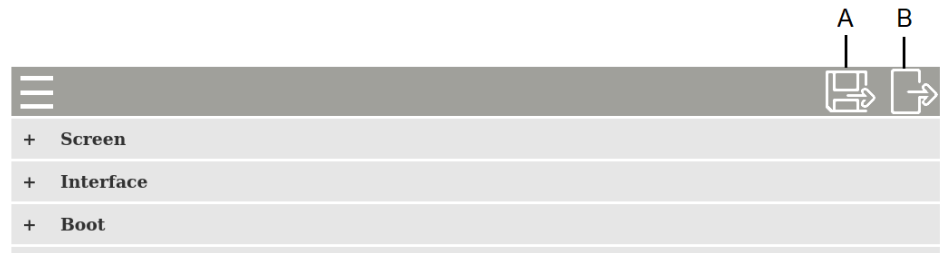

A. **Save & Reboot**

B. **Exit without Saving**

NOTE: After 10 minutes of screen inactivity, you will be automatically logged out and setting changes will be discarded.

Screen

- Screen

Brightness

1

Screen Saver

Mode

None ▾

Timer

min(s)

Brightness	Adjusts the brightness, from 1 (bright) to 16 (dark). The default setting is [1].
Screen Saver	Set up the screen saver status for when the time defined in Timer elapses. The default setting is [None]. None: No screen saver. Backlight Off: Turn off the backlight.
Timer	Enter the amount of time from the last screen input until the screen saver starts up. You can enter from 1 to 30 minutes.

Interface

- Interface

Buzzer

Enable Disable

Touch Calibration

Enable Disable

Keyboard Type

101 106

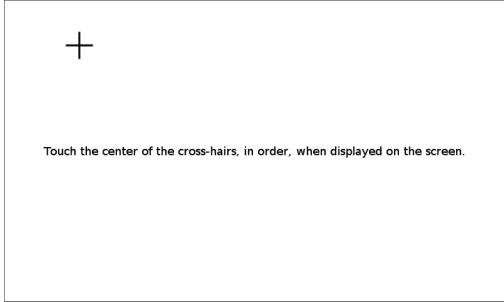
Buzzer	Enable or disable the buzzer that sounds when you perform touch-panel operations. The default setting is [Enable] .
Touch Calibration	<p>If [Enable] is selected, when this product restarts the calibration setting screen appears. Follow the instructions on the screen to run calibration. After calibration is complete, this product restarts. The default setting is [Disable].</p> 
Keyboard Type	<p>Select the USB keyboard type. The default setting is [101].</p> <p>101: Alphanumeric keyboard 106: Japanese input keyboard</p> <p>NOTE: When using a USB Japanese keyboard, Caps Lock is unavailable.</p>

Boot

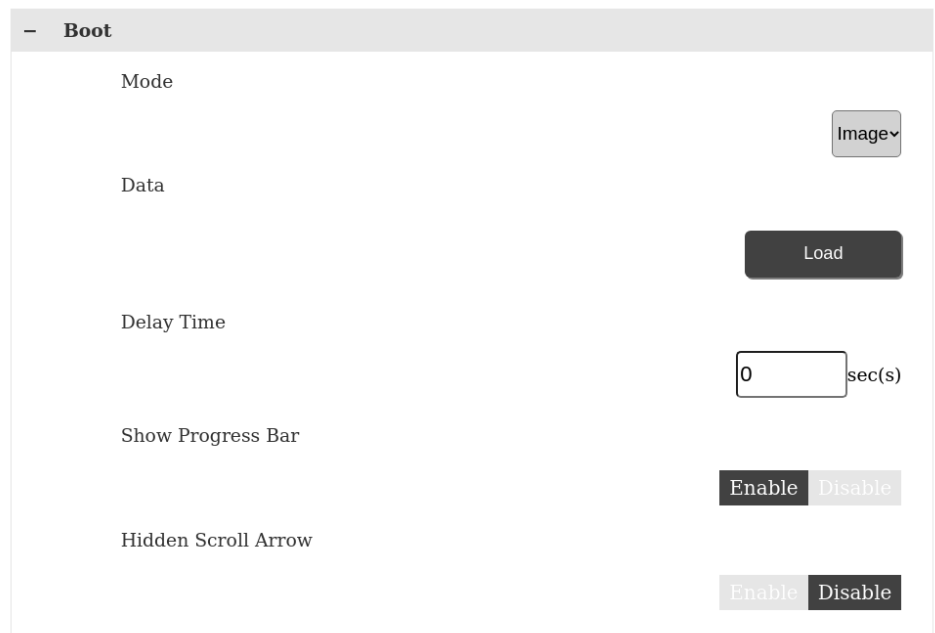

Mode	Set up the screen status at startup. To define an image, select [Image] , for no image display select [None] . The default setting is [Image] .
Data	<p>When Mode is set to [Image], touch Load to select the image to display from USB storage. The image must meet the following criteria.</p> <p>File size: Maximum 12 MB File format: png Image resolution: Maximum 2048 x 2048. Create the image with a resolution that matches the display resolution.</p>

	<p>NOTE: Requires saving the image with the file name "BootImg.png" to the root folder in USB storage.</p>
Delay Time	<p>Set the delay time from after the product starts until the screen set in the Server > Start Page is displayed. You can enter from 0 to 300 seconds*1.</p> <p>By setting the Delay Time, you can show the startup status until the Web server is running.</p> <p>*1 For products with a system version before V1.2.0, set from 0 to 60 seconds.</p>
Show Progress Bar	<p>Enable or disable the progress bar displayed during screen startup. The default setting is [Enable].</p> 
Hidden Scroll Arrow	<p>Hides the arrow buttons for scrolling the screen up, down, left, and right. The default setting is [Enable].</p>

Server

Register the web servers to connect to. You can register up to 10 web servers on the same intranet.

- Server

Start Page Configuration▼

- Server1

Name

URL

Connectivity Test

Software Keyboard Enable Disable

+ Server2

+ Server3

Start Page	<p>Select the first screen that appears when this product starts up. The default setting is [Configuration]. After registering web servers, you can select the web server screen as the start page.</p>	
Server list	Name	<p>Register Web servers of devices connected to the same Intranet. You can register up to 10 Web servers. Maximum 32 characters</p>

	URL	<p>Set the IP address of the web server in URL format. Maximum 256 characters</p> <p>Example 1: http://192.168.1.100</p> <p>Example 2: If the web page is on a specific port (port: 8080). http://192.168.1.100:8080</p> <p>NOTE:</p> <ul style="list-style-type: none"> • Always include "http://" as a prefix before your IP Address (or hostname). • HTTPS communication is not supported.
	Connectivity	<p>Touch Test button to check communication with the web server. The Test button color changes based on the state.</p> <p>Green: Communication is established.</p> <p>Red: Communication is lost (invalid or missing URL).</p> <p>Gray: Communication is being verified.</p> <p>NOTE: The Connectivity function is available for products using system version V1.1.0 or later.</p>
	Software keyboard	<p>Enable or disable the software keyboard. The default setting is [Enable].</p>

Network

– Network

DHCP Enable Disable

IP Address

Subnet Mask

Default Gateway

DNS Settings Auto Manual

DNS Server

MAC Address 00:80:11:ed:35:66

DHCP	<p>Select [Enable] to automatically get the IP address for this product from a DHCP server on the same Intranet. To specify a static IP address, select [Disable]. The default setting is [Disable].</p>
IP Address Subnet Mask	<p>Set the static IP address and subnet mask. With these settings, the product's network address and the Intranet network address must be the same.</p>

	<p>Example (bold text indicates numbers that are the same)</p> <p>STW6000 Series</p> <p>IP Address: 192.168.1.80</p> <p>Subnet Mask: 255.255.255.0</p> <p>External Device</p> <p>IP Address: 192.168.1.100</p> <p>Subnet Mask: 255.255.255.0</p>
Default Gateway	Enter the IP address of the default gateway.
DNS Settings DNS Server	<p>Sets up how to get the IP address from the DNS server. When [Auto] is selected, the IP address is automatically defined. When [Manual] is selected, enter the DNS server IP address in the DNS Server field. The default setting is [Manual].</p> <p>NOTE: When you want to select [Auto], first set DHCP to [Enable].</p>
MAC Address	Displays the MAC address on the product.

System

System

Password

Change

Load Default

Reset

Back Up Configuration

Backup

Restore Configuration

Restore

Update System

Update

<p>Password</p>	<p>To change the password, enter the new password twice and touch Change.</p> <p>Passwords must have at least one uppercase character, one lowercase character, and one number. The conditions for the password are as follows.</p> <p>Number of characters: 8 or more</p> <p>Usable characters:</p> <ul style="list-style-type: none"> • Uppercase letters: A to Z • Lowercase letters: a to z • Numbers: 0 to 9 • Special characters: - _ <p>NOTE:</p> <ul style="list-style-type: none"> • Spaces are not allowed. • Do not lose the password. If you lose the password, contact customer support for assistance. • For products with a system version before V1.1.0, the number of characters is 6 to 32.
<p>Load Default</p>	<p>Touch the Reset button and a dialog box appears. Touch Yes to reset all settings, except the password and boot image, to the factory defaults.</p>
<p>Backup Configuration</p>	<p>Save the settings to USB storage. Insert storage to the USB (Type A) port, and touch this button. The settings are saved with the file name "WTCONF0D.DAT" to the root folder in USB storage.</p>
<p>Restore Configuration</p>	<p>Restores the settings saved on USB storage. Insert storage to the USB (Type A) port, and touch this button. Requires settings be saved with the file name "WTCONF0D.DAT" to the root folder in USB storage.</p>
<p>Update System</p>	<p>Updates the system with the system file saved on USB storage. You can download the latest system files from our website.</p> <p>https://www.pro-face.com/trans/en/manual/1085.html</p> <p>The following are the system update files.</p> <p>WEBOS0D.SYS, BOOTLD0D.SYS</p> <p>These files should be stored at the root folder in USB storage.</p>

Login Statistics

– Login Statistics

Current Usage	37:56
Previous Usage	37:29
No. of failed login	0
Export Log Data	

<p>Current Usage</p>	<p>Displays the accumulated time from when you first turned on the product to your current log in to the Configuration Menu.</p>
<p>Previous Usage</p>	<p>Displays the accumulated time from when you first turned on the product to the time you previously logged in to the Configuration Menu.</p>

No. of failed login	Displays the number of unsuccessful login attempts from the last successful login to this login.
Export Log Data	Saves log data. Attach the storage device to the USB (Type A) port and touch the button. Exported log data is saved to the root folder in USB storage as "WTLOG0D.CSV".
Check Export Log Data	Log data saved to USB storage includes code to prevent falsifying data. Touch this button to check if the exported log data has been tampered with. [Good] displays when there has been no data tampering. [Invalid] displays when there may have been some data tampering. You may have to check on how data is managed at your company.

Information

- Information	
Version	W001-0001-0018
MAC Address	90-89-14-8d-e3-78
DHCP	Enable
IP Address	192.168.128.27
Subnet Mask	255.255.255.0
Default Gateway	192.168.128.1
License	
Copyright (c) 2020 Schneider Electric. All rights reserved.	

Version/Network/License information	Displays the system version of this product, network information such as the IP address, and license information of the software used in the product.
-------------------------------------	---

Maintenance

What's in This Chapter

Regular Cleaning 65
 Periodic Check Points..... 65
 Replacing the Installation Gasket..... 66
 Replacing the Backlight 66
 After-sales Service 67

Regular Cleaning

Cleaning this product

NOTICE
<p>EQUIPMENT DAMAGE</p> <ul style="list-style-type: none"> • Power off this product before cleaning it. • Do not use hard or pointed objects to operate the touch panel. • Do not use paint thinner, organic solvents, or a strong acid compound to clean the unit. <p>Failure to follow these instructions can result in equipment damage.</p>

When this product gets dirty, wipe this product with a soft, dry cloth or a soft cloth soaked in only water and wrung tightly.

NOTE: When the product is very dirty, soak the soft cloth in water with a neutral detergent, wring the cloth tightly and wipe the product while avoiding the product label.

Periodic Check Points

Operation Environment

- Is the ambient air temperature within the allowable range? Refer to Environmental Specifications, page 22.
- Is the ambient air humidity within the specified range? Refer to Environmental Specifications, page 22.
- Is the operating atmosphere free of corrosive gasses?

When this product is inside a panel, the ambient environment refers to the interior of the panel.

Electrical Specifications

- Is the input voltage appropriate? Refer to Electrical Specifications, page 21.
- Are all power cords and cables connected properly? Are there any loose cables?
- Are all installation fasteners holding the unit securely?
- Are there scratches or traces of dirt on the installation gasket?

Unit Disposal

When disposing this product, dispose it in a manner appropriate to, and in accordance with, your country's industrial machinery disposal/recycling standards.

Replacing the Installation Gasket

The installation gasket provides protection against dust and moisture. The gasket must be inserted correctly into the groove for moisture resistance for this product.

NOTICE

GASKET AGING

- Inspect the gasket periodically as required by your operating environment.
- Replace the gasket at least once a year, or as soon as scratches or dirt become visible.

Failure to follow these instructions can result in equipment damage.

NOTICE

EQUIPMENT DAMAGE

Be careful not to stretch the gasket unnecessarily.

Failure to follow these instructions can result in equipment damage.

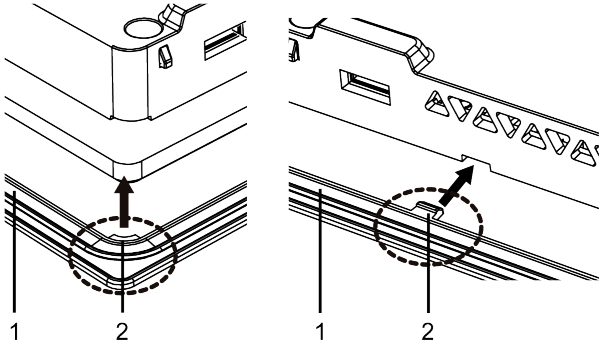
Step	Description
1	Place this product on a flat, level surface, with the display face pointing down.
2	Remove the gasket from this product.
3	<p>Attach the new gasket to this product. Insert the protrusions from the four corners of the gasket into the corresponding holes in the corners of this product.</p> <p>Depending on your model, there may be additional protrusions. In the following, refer to the figure on the right and insert the protrusions accordingly.</p> <p>NOTE: When using a tool to insert the gasket, make sure the tool does not catch the rubber gasket and cause a tear.</p>  <p>1 Installation gasket 2 Protrusion</p>

Replacing the Backlight

Not replaceable. Please contact customer support.

After-sales Service

For details on after-sales service, refer to our website.

<https://www.pro-face.com/trans/en/manual/1015.html>

Schneider Electric Japan Holdings Ltd.

4-4-9 Kitahama, Chuo-ku
Osaka, 541-0041 JAPAN

+ 81 (0) 50 4561 4800

www.pro-face.com

As standards, specifications, and design change from time to time, please ask for confirmation of the information given in this publication.

© 2024 Schneider Electric Japan Holdings Ltd. All rights reserved.

STW6000-MM01-EN.05